

AUSTRALIA

*Patents Act 1990*

**NOTICE OF ENTITLEMENT**

(To be filed before acceptance)

We, GINES CANOVAS, MARC DEBILLY and ROBERT GALVIN of, Le Bourg, F-69480 Amberieux-d'Azergues, France, Fourcon, F-69620 Saint-Laurent-d'Oingt, France and 6, rue Louis-Tellion, F-69100 Villeurbanne, France, being the applicant in respect of Application No. 75726/91 state the following:-

The Person nominated for the grant of the patent:

has entitlement from the actual inventors by assignment.

The person nominated for the grant of the patent:

has entitlement from the applicants of the applications listed in the declaration under Article 8 of the PCT by assignment.

The basic applications listed on the request form:

are the first applications made in a Convention country in respect of the invention.

By our Patent Attorneys,  
WATERMARK PATENT & TRADEMARK ATTORNEYS

  
L.J. Dyson  
Registered Patent Attorney

12 January 1994



AU9175726

**(12) PATENT ABRIDGMENT (11) Document No. AU-B-75726/91**  
**(19) AUSTRALIAN PATENT OFFICE (10) Acceptance No. 652932**

(54) Title  
**DEVICE FOR MONITORING THE WEAR ON A TYRE AND THE GEOMETRY OF A VEHICLE'S ROAD WHEELS**

International Patent Classification(s)  
 (51)<sup>5</sup> **G01B 005/18 B60C 011/24 G01B 01/3/28 G01B 005/255**

(21) Application No. : **75726/91** (22) Application Date : **19.03.91**

(87) PCT Publication Number : **WO91/14919**

(30) Priority Data

(31) Number	(32) Date	(33) Country
<b>90 03696</b>	<b>19.03.90</b>	<b>FR FRANCE</b>
<b>90 08198</b>	<b>25.06.90</b>	<b>FR FRANCE</b>

(43) Publication Date : **21.10.91**

(44) Publication Date of Accepted Application : **15.09.94**

(71) Applicant(s)  
**GINES CANOVAS; MARC DEBILLY; ROBERT GALVIN; GERARD RAFFAULT**

(72) Inventor(s)  
**GINES CANOVAS; MARC DEBILLY; CHRISTIAN BOIREAU; GERARD RAFFAULT**

(74) Attorney or Agent  
**WATERMARK PATENT & TRADEMARK ATTORNEYS , Locked Bag 5, HAWTHORN VIC 3122**

(56) Prior Art Documents  
**GB 2220491**  
**US 4195413**  
**US 3170243**

(57) Claim

1. Means for monitoring the wear of a tire and the geometry of a wheel set of a vehicle, of the type comprising a portable box (2a-2b-2c), a probe (4) which is movable with respect to a bearing face (15) and able to measure the depth of each groove of the tread (18) of the tire, means (6-8-9) converting the position of the probe into a signal, means (11a) memorizing this signal, means (10) of processing and of calculation processing each signal and sending a data item to a means of visual display (12), characterized in that they comprise, also, in the means of processing and of calculation (10), means converting each of the depth measurements, effected at at least two spaced lateral points on the tread, into a wear percentage determined by reference to a memorized value corresponding to a groove depth with nil wear, means bringing about the display and the memorizing of each measurement result, and at least one means of control (17-25-30) able to trigger the means of processing and of calculation (10) to compare the memorized measurement results and to send to the means of display (12) a data item indicating the wear and the geometry of wheel set of the tire.

DEMANDE INTERNATIONALE PUBLIEE EN VERTU DU TRAITE DE COOPERATION EN MATIERE DE BREVETS (PCT)

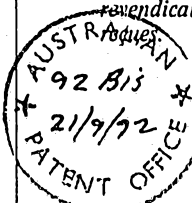
<p>(51) Classification internationale des brevets <sup>5</sup> : <b>G01B 5/18, 3/28, 7/26</b></p>	<p><b>A1</b></p>	<p>(11) Numéro de publication internationale: <b>WO 91/14919</b> (43) Date de publication internationale: 3 octobre 1991 (03.10.91)</p>
<p>(21) Numéro de la demande internationale: PCT/FR91/00221 (22) Date de dépôt international: 19 mars 1991 (19.03.91) (30) Données relatives à la priorité: 90/03696 19 mars 1990 (19.03.90) FR 90/08198 25 juin 1990 (25.06.90) FR  (71) Déposants (pour tous les Etats désignés sauf US): GALVIN, Robert [FR/FR]; 6, rue Louis-Teillon, F-69100 Villeurbanne (FR). RAFFAULT, Gérard [FR/FR]; Les Carrières, F-69480 Lucenay (FR).  (71)(72) Déposants et inventeurs: CANOVAS, Gines [FR/FR]; Le Bourg, F-69480 Ambérieux-d'Azergues (FR). DEBILLY, Marc [FR/FR]; Fourcon, F-69620 Saint-Laurent-d'Oingt (FR). RAFFAULT, Gérard; Les Carrières, F-69480 Lucenay (Rhône) (FR).</p>		<p>(72) Inventeur; et (75) Inventeur/Déposant (US seulement) : BOIREAU, Christian [FR/FR]; Chemin des Gorges, F-69370 Saint-Didier-au-Mont-d'Or (FR). (74) Mandataire: CABINET GERMAIN ET MAUREAU; 12, rue de la République, F-42000 Saint-Etienne (Loire) (FR). (81) Etats désignés: AT (brevet européen), AU, BE (brevet européen), CA, CH (brevet européen), DE (brevet européen), DK (brevet européen), ES (brevet européen), FR (brevet européen), GB (brevet européen), GR (brevet européen), IT (brevet européen), JP, KR, LU (brevet européen), NL (brevet européen), SE (brevet européen), US.</p> <p style="text-align: center;">Publiée Avec rapport de recherche internationale. Avant l'expiration du délai prévu pour la modification des revendications, sera republiée si de telles modifications sont</p> <div style="text-align: center;">  <p style="font-size: 2em; font-weight: bold; margin-left: 20px;">652932</p> </div>

see folio 4

(54) Title: DEVICE FOR MONITORING THE WEAR ON A TYRE AND THE GEOMETRY OF A VEHICLE'S ROAD WHEELS

(54) Titre: MOYENS POUR CONTROLER L'USURE D'UN PNEUMATIQUE ET LA GEOMETRIE D'UN TRAIN DE ROUES D'UN VEHICULE

(57) Abstract

This device is of the type comprising, in a portable box, a probe (4) for measuring the depth of each tread groove and means (6-8-9) converting the position of the probe into a signal, means (11a) memorising this signal and processing and calculating means (10) transmitting information to a display (12). According to the invention it also comprises, in the processing and calculating means (10), means for converting each measurement into rate of wear, and memorising each measurement result, and at least one control means (30) capable of triggering the processing and calculating means (10) to compare the memorised results and transmit information indicating the condition of the tyre geometry to the display (12).

(57) Abrégé

Ces moyens sont du type comprenant dans un boîtier portable, un palpeur (4) apte à mesurer la profondeur de chaque gorge et des moyens (6-8-9) convertissant la position du palpeur en un signal, des moyens (11a) mémorisant ce signal, des moyens (10) de traitement et de calcul envoyant une information à un afficheur (12). Selon l'invention, ils comprennent, aussi, dans les moyens de traitement et de calcul (10) des moyens convertissant chaque mesure en taux d'usure des moyens provoquant l'affichage et la mémorisation de chaque résultat de mesure, et au moins un moyen de commande (30) apte à déclencher les moyens de traitement et de calcul (10) pour comparer les résultats mémorisés et envoyer à l'afficheur (12) une information indiquant l'état de la géométrie du pneumatique.

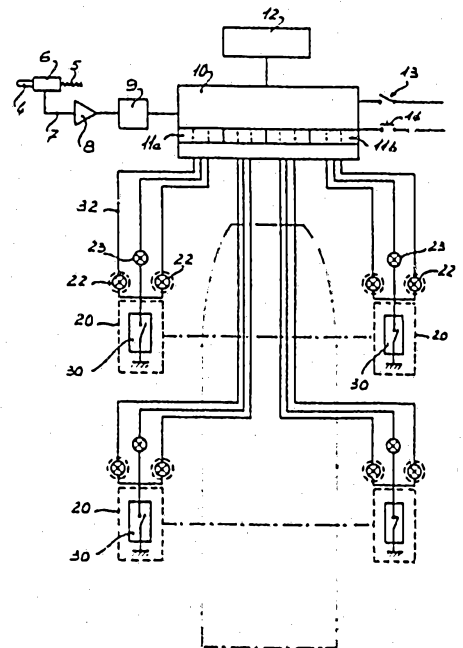

"Means for monitoring the wear of a tire and the geometry of a wheel set of a vehicle."

In order to monitor the wear of a tire, it is known to use depth gauges comprising a probe able to engage into each groove of a tire, a bearing face able to come into contact with the peaks of the ribs and a means of reading giving the depth of engagement of the probe in the groove.

Such gauges are either mechanical, in which case the reading is effected on a graduated scale, or electronic, in which case they comprise means converting the position of the probe into an analog or digital electrical signal, means of processing and of calculation and means of display of the result of the measurement.

The device described in the patent US 4 631 831 also comprises means memorizing the values of each measurement, calculating the mean value of these measurements and transmitting this result to the means of display.

Such an apparatus thus provides the mean value, expressed in millimeters, of the depth of the ribs and, consequently, merely indicates a value relating to the wear of the tire permitting management of a fleet of vehicles.

The aim of the present invention is to provide means, of the type quoted above, which permit, in addition to and on the basis of a measurement of the wear of a tire, detection of faults in geometry of the wheel set carrying this tire, namely, camber, parallelism, caster, and to do so without the operator needing to carry out any calculations.

These means are of the type comprising a portable box, a probe which is movable with respect to a bearing face and able to measure the depth of each groove of the tread of the tire, means converting the position of the probe into a signal, means memorizing this signal, means of processing and of calculation processing each signal and sending a data item to a means of visual display.

According to the invention, they also comprise means converting each of the depth measurements, effected at at least two opposed lateral points on the tread, into the form of a rate of wear, determined by reference to a groove depth corresponding to nil wear and memorized in the means of processing and of calculation, means bringing about the display and the memorizing of each measurement result, and at least one means of control able to trigger the means of processing and of calculation to compare the memorized measurement results and to send to the means of display a data item indicating the state of the geometry of the tire.

Thus, after having taken account of the rate of wear of the tire on each measurement region, the operator can, by simple action on a manual control and by virtue of the means of processing and of calculation previously used for converting the depth into a percentage, bring about the display of a data item on the state of the geometry of the wheel set. *The rate of wear or wear can be expressed as a percentage of how much tread has worn away from the original tread size. As an example, if a new tread measuring 10mm and over 10,000 km this wears down to 7mm the rate of wear expressed as a percentage is 30% or 3mm in 10mm wear.*

According to the embodiments, this data item is constituted by the most significant rate of wear or by the rate corresponding to the deviation between the measured wears. Needless to say, if the deviation between the displayed wears is nil, the means of display indicate a nil value, that is to say zero, which indicates that the wear of the tread is uniform and that the geometry of the wheel set does not have to be examined, which is not the case for any other value of deviation.

In one embodiment of the invention, the means of monitoring comprise, on the face of the box incorporating the means of display and in proximity to a symbolic representation of at least one wheel of the vehicle, on the one hand, as many means of light signalling as the number of measurements having to be effected on each tire, these means being arranged with respect to the representation of the wheel in the same way as the measurement regions on the tread, on the other hand, a means of control triggering, after carrying out the



measurements on each wheel, the means of processing and of calculation to compare the memorized values of the depth measurements effected, to display on the screen the maximum value indicated in the form of a rate with respect to nil wear and to control the supply, nil or permanent, of the light means in relation to the rate of wear peculiar to the position of each means, and moreover, another means of control triggering, at the end of the measurement cycle for a wheel, the means of processing and of calculation to compare the memorized values of the depth measurements and to display the deviation between these values on the screen.

With this apparatus, at the end of measurement of a wheel and by actuating the means of control, the operator can be informed of the value of the maximum rate of wear, by reading the display means, and the location of this rate, by examining the means of light signalling. By examining the means of display he is also informed of the rate corresponding to the deviation between the measurements of wear, and thus of the state of the geometry of the wheel set carrying the wheel.

In one embodiment of the invention, these means comprise, on the face of the box incorporating the means of display and in proximity to a symbolic representation of at least one wheel of the vehicle, on the one hand, at least as many means of light signalling as the number of measurements having to be effected on each tire, these means being arranged with respect to the representation of the wheel in the same way as the measurement regions on the tread, on the other hand, on a circuit of the means of processing and of calculation dedicated to the means of light signalling, a trigger contact for a measurement cycle comprising the following sequences:

- supply of the means of light signalling allocated to the first measurement of the cycle,

- after validation of the first measurement, processing of the signal S1 of the validated measurement, display of a rate of wear corresponding to this signal,

memorization of this signal, comparison of this signal S1 with a value VR corresponding to nil wear and memorization of the residual value V1, and so on for each of the measurements on a wheel,

5           - at the end of measurement of a wheel, comparison of the extreme measurements, display of the result R1 of this comparison giving the rate of the deviation in wear of the tread,

          - comparison of the result R1 with a value K, corresponding to the maximum tolerated deviation and obtainment of a memorized value R2,

10           - summation of the memorized results V1...Vn, R2, analysis of the sum obtained and transmission to the light means of a supply command, which is nil, permanent or intermittent in relation to the state of the tire and  
15 the position on the latter of maximum wear.

          With this monitoring apparatus, after selection on the box of the wheel which has to be measured, the operator is guided in its measurement by the light means  
20 of the box, is automatically informed, by a display in the course of measurement, of the rate of wear resulting from the current measurement and, at the end of a cycle of measurement and by display, of the rate corresponding to the deviation between the various measurements. At the  
25 end of measurement, he is also informed of the state of wear of the tire and of the geometry of the wheel set carrying the wheel by synoptic means constituted by the light means arranged at the side of a representation of the wheel.

30           Other characteristics and advantages will emerge from the description which follows with reference to the attached diagrammatic drawing, representing, by way of non-limiting examples, several embodiments of the means according to the invention.

35           Figure 1 is a view in perspective showing a first embodiment of the monitoring apparatus,

          Figure 2 is a diagrammatic view representing its essential components,

Figure 3 is a partial sectional view showing the conditions of use of the apparatus, when its probe is introduced into one of the grooves of the tread of a tire,

5           Figure 4 is a view in perspective showing another embodiment of the apparatus,

Figure 5 is a diagrammatic view of the components of the apparatus of figure 4,

10           Figure 6 is a plan view from above representing another embodiment of the apparatus,

Figure 7 is a diagrammatic view of the components of the apparatus of figure 6.

All the apparatuses represented in the drawing comprise a portable box respectively 2a-2b and 2c, a  
15           depth gauge designated by 3 overall and whose probe 4, loaded by a spring 5, is associated with a sensor 6 converting the displacements of the probe into proportional or digital electrical signals. As Figure 2 shows, the sensor is linked by a circuit 7 to an  
20           amplifier 8 followed, if the signals transmitted by the sensor 6 are analog, by an analog-digital convertor 9. The circuit 7 terminates in an assembly for processing and calculation 10, constituted in general by a  
25           microprocessor, controlling the operation of the means of display 12, for example a liquid crystal display. Each apparatus also comprises a start-stop button 13 and means 14 of validation of the measurement effected, means which, in the embodiment of Figures 1 and 6, are constituted by a push button, while, in the embodiment  
30           represented in Figure 4, they are constituted by a contact arranged in the nose 15 of the apparatus. The means of processing 10 are associated with erasable memories 11a, and with non-erasable memories 11b, and with means of zero resetting of the memories 11a.

35           In the embodiment represented in Figures 1 to 3, the monitoring apparatus comprises two means of control 16-17 constituted by push buttons accessible from the upper face of the box and able to trigger the operation

of the means of processing and of calculation 10.

More precisely, after the apparatus has been put into operation by actuating the start-stop button 13, the operator engages the probe 4 of the latter into one of the lateral grooves 18 of the tread of a tire 19, taking care to give this probe a radial direction with respect to the axis of rotation of the wheel. When the probe is in contact with the bottom of the groove, the operator continues to bring the apparatus close until its nose 15 comes to abut on the face of the ribs bordering the groove. Under these conditions, the means 6 convert the position of the probe 4 into analog signals. These signals are converted by the means 9 into digital signals. The means of processing and of calculation memorize this data item and, possibly, compare it with a memorized value corresponding to a groove depth having a nil rate of wear, and send a data item on the rate of wear to the display 12. Next in the process is at least one second measurement in the groove of the tread opposite to that where the first measurement was effected. The signals corresponding to the depth measured are also memorized and possibly compared to the reference value in order to send another data item on the rate of wear to the display 12.

When these measurements have been effected, the operator actuates the button 16, which has the effect of bringing the means of processing and of calculation 10, to compare the memorized values of the first two measurements, of selecting the value corresponding to the greatest wear of the tread, of transforming this value into a percentage and of bringing about the display of this percentage on the display 12. When the operator presses on the contact 17, the means of processing and of calculation again compare the two memorized values and, if there is a deviation between them, convert this deviation into a difference in wear which is displayed on the display 12.

It emerges from the foregoing that after monitoring of the rate of wear of the tread of the tire, the operator can, by simple reading of the display 12, know the difference in wear and deduce, from the state of the treads, the state of the geometry of the means linking the wheel to the chassis of the vehicle. More precisely, if the deviation between the two values measured is nil, the wear of the tire is uniform, but if this deviation has a value lying between 0 and 99%, this indicates that the tread is inclined with respect to the x'-x position that its peripheral face should have, and that manifestly there exists a misalignment of the geometry of the means of linking of the wheel with respect to the chassis, or deterioration of the chassis.

In the embodiment represented in Figures 4 to 5, the monitoring apparatus comprises on one of the faces of its box 2, four graphical representations 20 of the four wheels of a vehicle, and distributed like them on the face of the box. Each graphical representation is associated with means of light signalling 22 constituted, for example, by electroluminescent diodes. The number of these means 22 is equal to the number of measurements which it is advisable to effect on the tread of each wheel, and, for example, are two in number in this embodiment. Figure 4 shows that the diodes 22 are arranged with respect to the graphical representation 20 of the wheel in the same way that the measurements on the tread of this wheel have to be effected. In this embodiment, they are associated with another diode 23 arranged differently with respect to them and, for example, in front. In practice, the diode 23 is green in color and those 22 are red in color.

As Figure 5 shows, the control circuit for the means of processing 10 comprises two buttons 24 and 25, acting on the supply to the diodes 22 and 23, and a button 26 triggering the operation of a printer 27 under the control of the means of processing and of calculation 10. These buttons 24 to 26 are accessible from the face

of the box 2b incorporating the graphical representations 20 of the wheels.

In the measurement phase, the operation of this monitoring apparatus is the same as that previously described, namely that, for each wheel, the operator effects a probing at two opposed points on the tread and that the value of the groove depths, converted into digital signals, is memorized in the means of processing and of calculation 10 until the operator actuates the button 24. Under these conditions and as before, the means of processing and of calculation 10 compare the measured values, select the greatest value and send, to the display 12, a value indicating the rate of wear corresponding to this value. Simultaneously, the means of processing and of calculation 10 command the supply to the diodes 22 and 23 as a function of the measurement, namely supply to the diode 23, green in color, if the tread exhibits normal wear, within the allowable limits, or supply to one of the diodes 22 if the wear observed is beyond the normal value. Under these conditions, diode 22 which is supplied, is that which is situated inside the box, if the tread is more worn towards the inside, and that outside the box, if this tread is more worn over its outer part.

Faced with these visual and light data, the operator deduces whether he is in the presence of a misalignment of the geometry of the wheel set, a misalignment whose value he obtains by actuating button 25. In fact, under these conditions and as for button 17 of the preceding embodiment, the means of processing and of calculation 10 compare the two values of the measurements and convert the deviation in them into a percentage which is displayed on the display 12. This deviation can also be supplied on a medium, by actuating button 26 controlling the starting of the printer 27.

In one embodiment variant, the means of light signalling 23 are constituted by a two-color diode, red and green. In this configuration, at the end of

comparison of the measured values, the state of wear of the tire is signalled either by the color green, if the wear is normal, or by the color red if the wear is considered abnormal, and this occurs independently of the light means constituted by the diodes 22 which indicate the side of the misalignment.

Although, in the two preceding embodiments, the monitoring apparatus according to the invention permits indication of the state of misalignment of the geometry of a wheel on its wheel set, and does so without the operator having to carry out any calculation, it is still possible, through errors in manipulation or in positioning of the box with respect to the wheels in the measurement phase, to arrive at errors of interpretation of the indications supplied by the display by the diodes. In order to remedy this, the apparatus represented in Figures 6 to 7 incorporates, for each group of light means 22-23, and under the graphical representations 20 of each wheel of the vehicle, a button 30 which acts on the means of processing and of calculation 10 in order to, on the one hand, organize and manage the measurements, and on the other hand, launch a measurement cycle for each wheel.

With this apparatus, after actuating the stop-start button 13 controlling its supply, the operator must first of all proceed to the selection on the apparatus of the graphical representation 20 of the wheel which he envisages measuring. This selection is effected by pushing on the button 30 arranged under the chosen graphical representation. This contact, arranged on a circuit 32 of the means of processing and of calculation 10, which is dedicated to the light means 22 and 23 which are juxtaposed with the representation 20 chosen, triggers the measurement cycle peculiar to the wheel, a cycle whose first sequence consists in bringing about the supply to the diode 23 and to one of the diodes 22, namely, for example, that arranged at the outside on the representation. By illumination of these diodes, the

operator is informed that the group is selected, that the measurement cycle will commence and that he must engage the probe 4 of the box in the outermost groove of the tread of the chosen wheel.

5           As in the preceding embodiments, the operator engages the probe 4 in the chosen groove 18 until contact with its bottom and continues to advance the apparatus until the bearing face of the nose comes into contact with the tread.

10           During this operation, the unit for processing and for calculation 10 sends to the display 12 data which permit it to display a rate of wear which goes on increasing until contact of the nose 15 on the tread.

15           When the operator presses on the validation button 14, the value S1 corresponding to the rate displayed is memorized and compared with a value VR corresponding to nil wear. The residual value V1, resulting from this comparison, is memorized in its turn.

20           At the end of this first measurement operation, the unit for processing 10 interrupts the supply to the diode 22 arranged at the outside of the same graphical representation 20 and commands the supply to the diode 22 arranged inside the same representation in order to signal to the operator that he can effect the second measurement on the inner side of the tread. The measurement procedure is the same and leads to the memorizing of a signal S2 and of a residual value V2.

25           At the end of measurement of a wheel, the unit for processing and for calculation 10 compares the values of the extreme measurements S1-S2, and sends to the display 12 a data item R1 corresponding to the difference between these values, expressed as a rate of wear, <sup>or wear percentage</sup> of the result R1 obtained. The result of this is that the operator instantly has knowledge of the deviation of the rate of wear on the tread, and, consequently, of the state of misalignment of the geometry of the wheel on its wheel set.

30

35



Simultaneously, the unit for processing and for calculation compares the value of R1 with a value K corresponding to the maximum tolerated deviation and memorizes the value of the result R2 obtained. This value  
5 K is either memorized, or calculated.

The means of processing then carry out the summing of the digital values of the memorized results V1-V2-R2, analyze the final result and transmit to the light means 22 and 23 a command for nil, permanent or  
10 intermittent supply, in relation to the state of the tire and the position on the latter of the fault in geometry.

More precisely, when the result of the summation indicates that the tire is in a good state of wear, and is without geometric fault, the means of processing  
15 command the supply to the diode 23 of green color. If the summation makes it apparent that the maximum wear is exceeded on one side of the tread, the means of processing 10 bring about the supply to the corresponding red diode 22, a diode which also indicates faults in geo-  
20 metry. In the presence of an exceeded maximum wear over the whole width of the tread, the two red diodes 22 are supplied. Finally, in the presence of an excessive asymmetry of wear on one side, the corresponding red diode is supplied intermittently, in order better to draw  
25 attention.

It emerges that at the end of a measurement cycle for one wheel, and complementing the data given by the display 12, the operator has available a synoptic light  
30 data item pointing him towards his final decision to replace the tire or to proceed to the checking of the geometry of the wheel on its wheel set.

Needless to say, the operator proceeds in the same way for each of the wheels of the vehicle and by virtue of the maintenance of the electrical supply to the  
35 light means of the various groups corresponding to the wheels of the vehicle, the operator has available, at the end of the monitoring operation of the wheels of a vehicle, a synoptic table retracing all the faults picked

up and permitting him all the better to appreciate the faults in geometry in the wheel sets, if any exist.

In one embodiment variant, the measurement cycle triggered by one of the two control buttons 30 associated with any one of the wheels of a wheel set, comprises, after the measurement of the wheels of the wheel set, the comparison between the memorized values S1-S2 of one wheel and the memorized values S1'-S2' of the other wheel of the same set, the selection of the value corresponding to the greatest wear, the comparison of this residual value with a memorized reference value H, corresponding to the maximum tolerated deviation between the wears of the two wheels of the same set. On the basis of a threshold of the value obtained by this comparison, the means of processing and of calculation 10 command the supply to the means of signalling 22 arranged, on the synoptic representation of the wheel set, at the same place where the greatest wear on the wheels monitored is situated.

This additional cycle makes it possible to check the geometry of the wheel set, especially, when the rates of wear of each of the wheels have insufficient deviations to be considered as a fault in geometry of the wheel set.

It is obvious that the device, which has been described above in the context of its application to the monitoring of the wear of tires and to the monitoring of the geometry of the wheel sets of a motor vehicle with four wheels, can be configured, without departing from the scope of the invention, to permit the monitoring of a vehicle comprising more than four wheels, such as a lorry. In the same way, it would not depart from the scope of the invention to associate with each wheel, not only two means of light signalling 22, but three or four, for example to effect three or four measurements on wide tires.

Finally, the microprocessor 10, which is arranged in the box, can, in a known way, be connected, for

example by a socket 40 visible in Figure 4, to any other means of processing of the digital data or to means making it possible to formalize, on paper or on magnetic medium, the data contained in its temporary memories 11a.

THE CLAIMS DEFINING THE INVENTION ARE AS FOLLOWS:

1. Means for monitoring the wear of a tire and the geometry of a wheel set of a vehicle, of the type comprising a portable box (2a-2b-2c), a probe (4) which is movable with respect to a bearing face (15) and able to measure the depth of each groove of the tread (18) of the tire, means (6-8-9) converting the position of the probe into a signal, means (11a) memorizing this signal, means (10) of processing and of calculation processing each signal and sending a data item to a means of visual display (12), characterized in that they comprise, also, in the means of processing and of calculation (10), means converting each of the depth measurements, effected at at least two spaced lateral points on the tread, into a wear percentage determined by reference to a memorized value corresponding to a groove depth with nil wear, means bringing about the display and the memorizing of each measurement result, and at least one means of control (17-25-30) able to trigger the means of processing and of calculation (10) to compare the memorized measurement results and to send to the means of display (12) a data item indicating the wear and the geometry of wheel set of the tire.

2. Means according to Claim 1, characterized in that they comprise at least one of control (16) triggering, after carrying out the measurements, the means (10) of processing and of calculation to compare the memorized values of the depth measurements effected on the tire and to send to the means of display (12) a data item corresponding to the wear percentage of the tread of the tire in its most-worn parts.

3. Means according to any one of Claims 1 and 2, characterized in that they comprise, on the face of the box (2b) incorporating the means of display (12) and in proximity to a symbolic representation (20) of at least one wheel of the vehicle, as many light signal means (22) as the number of measurements having to be effected on each tire, said light signal means (22) being arranged with respect to the representation (20) of the wheel corresponding to the measurement regions on the tread; a means of control (24) triggering, after carrying out the



measurements on each wheel, the means (10) of processing and of calculation to compare the memorized values of the depth measurements effected, to communicate to the display (12) a data item on the maximum value indicated in the form of a wear percentage with respect to nil wear and to control the supply, or the absence of supply, of said light signal means (22) in relation to the wear percentage unique to the position of each light signal means, and moreover, another means of control (25) triggering, at the end of the measurement cycle for a wheel, the means (10) of processing and of calculation to compare the memorized values of the depth measurements and communicate to the display (12) a data item on the deviation between these values.

4. Means according to Claim 1, characterized in that they comprise on the face of the box (2c) incorporating the means of display (12) and in proximity to a symbolic representation (20) of at least one wheel of the vehicle, at least as many light signal means (22) as the number of measurements having to be effected on each tire, these means being arranged with respect to the representation (20) of the wheel corresponding to the measurement regions on the tread; and on a circuit (32) of the means (10) of processing and of calculation dedicated to the light signal means (22), a means of triggering of a measurement cycle comprising the following sequences:

- connecting supply to the light signal means (22) allocated to the first measurement of the cycle,

- producing from the first measurement, a signal S1 and a display of a wear percentage corresponding to this signal, memorization of this signal, comparison of this signal S1 with a value VR corresponding to nil wear and memorization of the residual value V1, being equal to the difference between S1 and VR and so on for each of the measurements on a wheel, to produce signals S2, S3....Sn, and residual values V2, V3...Vn,

- at the end of measurement of a wheel, comparing of the extreme signals S1, S2, to display a result R1 expressed as a rate of wear or wear percentage of the difference between the two values S1 and S2,



- comparison of the result R1 with a value K, corresponding to a maximum tolerated deviation and obtainment of a memorized value R2,

- summation of the memorized results V1, Vn and R2, analysis of the sum obtained and transmitting to said light signal means (22) of a supply command to cause said light signal means (22) to not signal, signal intermittently or signal continuously as an indication of the state of the tire and the position on the latter of maximum wear.

5. Means according to any one of Claims 3 and 4, characterized in that they comprise at least four groups of light signal means (22) each juxtaposed with the representation (20) of a wheel.

6. Means according to Claim 5, characterized in that the wheel representations (20), each associated with a group of light signal means (22) are distributed on the face of the box like the wheels of a vehicle and each of these groups is associated with the means (30) of selection of the wheel and of initiating the measurement cycle.

7. Means according to any one of Claims 1, 4, 5 and 6 characterized in that the measurement cycle comprises, after the measurement of the wheels of the same wheel set, the comparison between the memorized measurements of the digital signals originating from a measurement cycle of two different wheels of the wheel set in question, the selection of the values corresponding to the greatest deviation, between said memorized measurements from two different wheels, and comparing of this deviation with a memorized reference value H, corresponding to the maximum tolerated deviation allowable between two wheels and on the basis of a threshold of the value thus obtained, the light signal means (22) indicating the position where the greatest wear value or deviation is located on the tire of the wheel set in question.

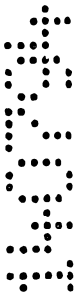

8. Means according to any one of the Claims 4 to 7, characterized in that the light signal means (22) allocated to a wheel are associated with another means (23) of light signalling which, offset with respect to them, but supplied, like them, under the control of the means (10) of processing and of calculation, constitutes a visual means of confirmation of the selection of the wheel and a means of indication of the good state of wear of the tire.

DATED this 7th day of July, 1994.

GINES CANOVAS, MARC DEBILLY and ROBERT GALVIN

WATERMARK PATENT & TRADEMARK ATTORNEYS  
THE ATRIUM  
290 BURWOOD ROAD  
HAWTHORN VICTORIA 3122  
AUSTRALIA

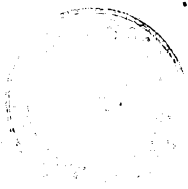
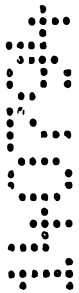
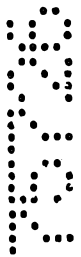

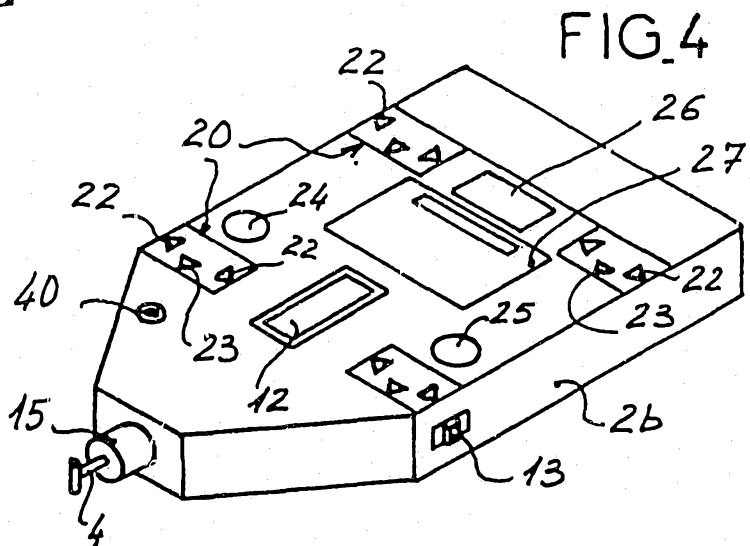
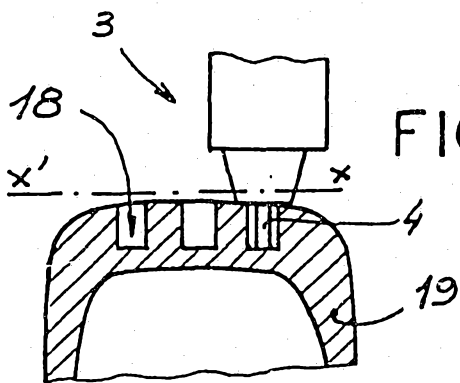
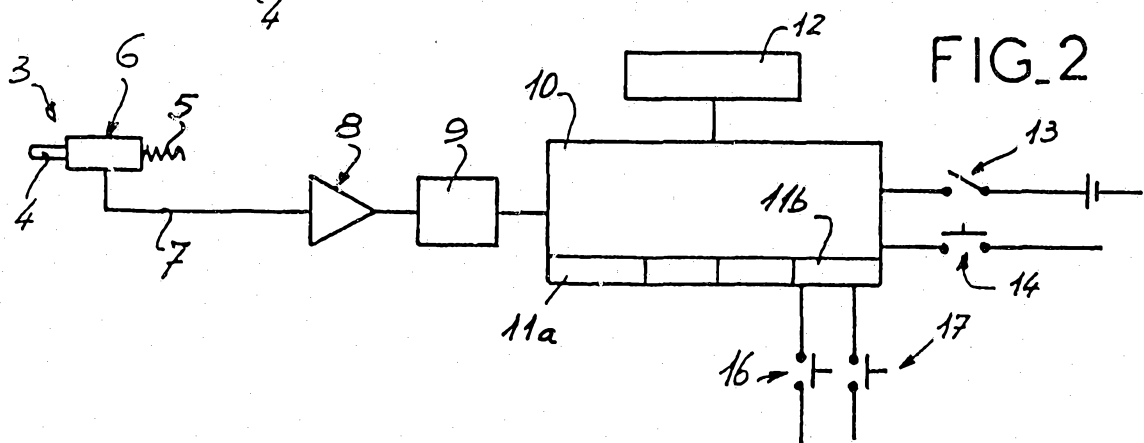
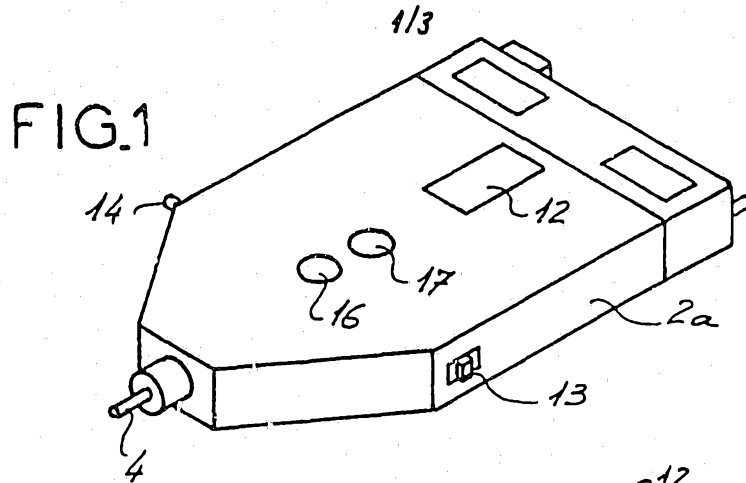

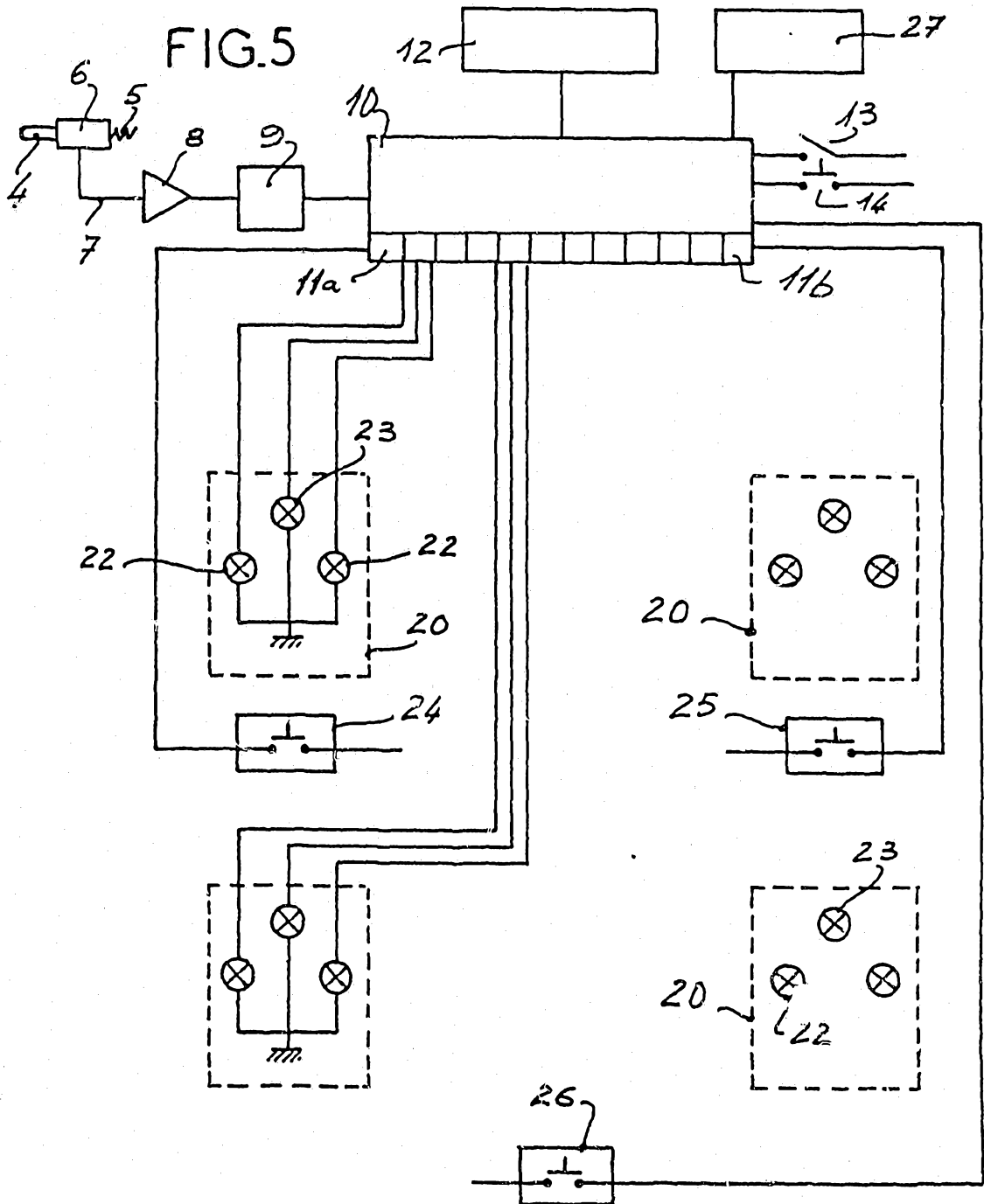
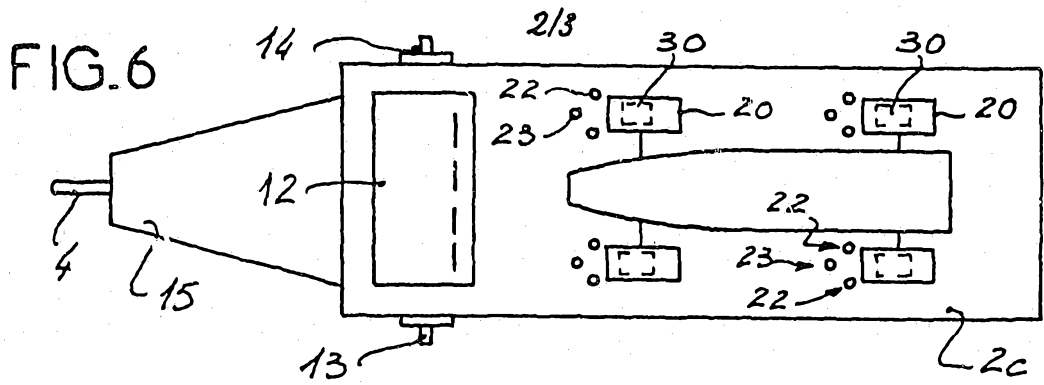
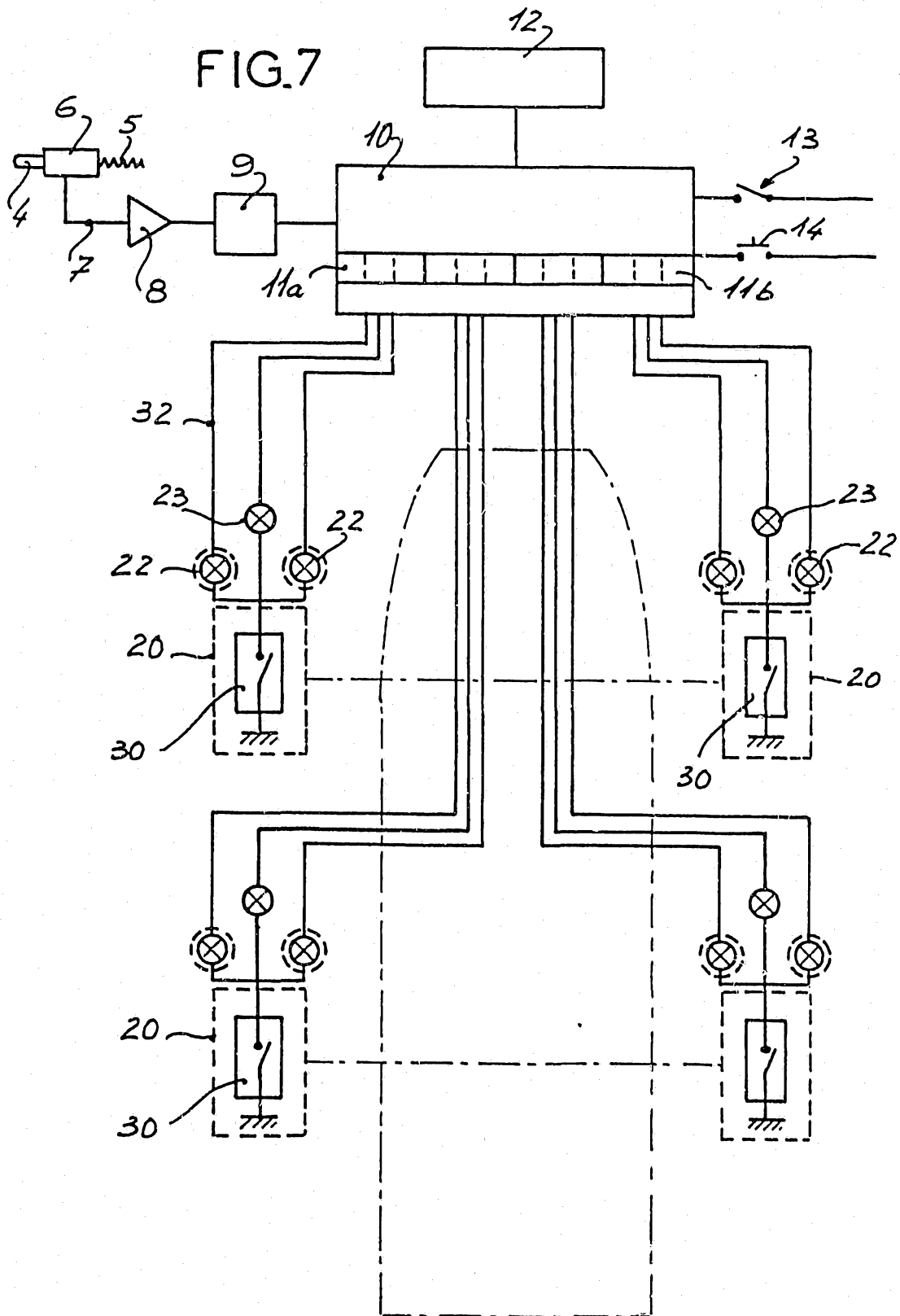

FIG.7



# INTERNATIONAL SEARCH REPORT

International Application No PCT/FR 91/00221

<b>I. CLASSIFICATION OF SUBJECT MATTER</b> (If several classification symbols apply, indicate all) <sup>8</sup>		
According to International Patent Classification (IPC) or to both National Classification and IPC		
Int.Cl. <sup>5</sup>	G 01 B 5/18 , 3/28 , 7/26	
<b>II. FIELDS SEARCHED</b>		
Minimum Documentation Searched <sup>7</sup>		
Classification System	Classification Symbols	
Int.Cl. <sup>5</sup>	G 01 B 3/00, 7/00, 5/00, 21/00, G 01 M 17/00	
Documentation Searched other than Minimum Documentation to the extent that such Documents are Included in the Fields Searched <sup>9</sup>		
<b>III. DOCUMENTS CONSIDERED TO BE RELEVANT <sup>9</sup></b>		
Category <sup>10</sup>	Citation of Document, <sup>11</sup> with indication, where appropriate, of the relevant passages <sup>12</sup>	Relevant to Claim No. <sup>13</sup>
A	Patent Abstracts of Japan, volume 4, no. 153 (P-33) (635), 25 October 1980, & JP, A, 55101803 (BRIDGESTONE TIRE K.K.), 1980  ---	1-6
A	Patent Abstract of Japan, volume 7, no. 212 (P-224) (1357), 20 September 1983 & JP, A, 58106405 (SUMITOMO GOMU KOGYO K.K.), 24 June 1983  ---	1
A	DE, A1, 2900040 (BRIDGESTONE TIRE CO.LTD) 26 July 1979 see claims 1-12  ---	1-6
A	US, A, 4227308 (A.R. TALANSKY et al.) 14 October 1980 see columns 2-4  ---	1-6
<p><sup>10</sup> Special categories of cited documents:</p> <p>"A" document defining the general state of the art which is not considered to be of particular relevance</p> <p>"E" earlier document but published on or after the international filing date</p> <p>"L" document which may throw doubts on priority claim(s) or which is cited to establish the publication date of another citation or other special reason (as specified)</p> <p>"O" document referring to an oral disclosure, use, exhibition or other means</p> <p>"P" document published prior to the international filing date but later than the priority date claimed</p> <p>"T" later document published after the international filing date or priority date and not in conflict with the application but cited to understand the principle or theory underlying the invention</p> <p>"X" document of particular relevance; the claimed invention cannot be considered novel or cannot be considered to involve an inventive step</p> <p>"Y" document of particular relevance; the claimed invention cannot be considered to involve an inventive step when the document is combined with one or more other such documents, such combination being obvious to a person skilled in the art.</p> <p>"&amp;" document member of the same patent family</p>		
<b>IV. CERTIFICATION</b>		
Date of the Actual Completion of the International Search		Date of Mailing of this International Search Report
5 June 1991 (05.06.91)		19 July 1991 (19.07.91)
International Searching Authority		Signature of Authorized Officer
European Patent Office		

III. DOCUMENTS CONSIDERED TO BE RELEVANT (CONTINUED FROM THE SECOND SHEET)		
Category *	Citation of Document, with indication, where appropriate, of the relevant passages	Relevant to Claim No
A	US, A, 3170243 (S.T. WILLIAMS) 23 February 1965 see claims 1-6  -----	1
A	GB, A, 2220491 (HSI-KUANG WENG) 10 January 1990 see claims 1-3  ----	1
A	GB, A, 2219401 (H.K. WENG) 6 December 1989 see claims 1-4  -----	1

**ANNEX TO THE INTERNATIONAL SEARCH REPORT  
ON INTERNATIONAL PATENT APPLICATION NO.**

FR 9100221  
SA 46261

This annex lists the patent family members relating to the patent documents cited in the above-mentioned international search report. The members are as contained in the European Patent Office EDP file on 16/07/91. The European Patent Office is in no way liable for these particulars which are merely given for the purpose of information.

Patent document cited in search report	Publication date	Patent family member(s)	Publication date
DE-A- 2900040	26-07-79	JP-A- 54099662 US-A- 4195413	06-08-79 01-04-80
US-A- 4227308	14-10-80	None	
US-A- 3170243		None	
GB-A- 2220491	10-01-90	DE-A- 3827456	15-02-90
GB-A- 2219401	06-12-89	US-A- 4884175	28-11-89

# RAPPORT DE RECHERCHE INTERNATIONALE

Demande internationale N° PCT/FR 91/00221

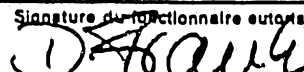
<b>I. CLASSEMENT DE L'INVENTION</b> (si plusieurs symboles de classification sont applicables, les indiquer tous) <sup>7</sup>		
Selon la classification internationale des brevets (CIB) ou à la fois selon la classification nationale et la CIB		
CIB <sup>5</sup> : G 01 B 5/18, 3/28, 7/26		
<b>II. DOMAINES SUR LESQUELS LA RECHERCHE A PORTÉ</b>		
Documentation minimale consultée <sup>8</sup>		
Système de classification	Symboles de classification	
CIB <sup>5</sup>	G 01 B 3/00, 7/00, 5/00, 21/00, G 01 M 17/00	
Documentation consultée autre que la documentation minimale dans la mesure où de tels documents font partie des domaines sur lesquels la recherche a porté <sup>9</sup>		
<b>III. DOCUMENTS CONSIDÉRÉS COMME PERTINENTS</b> <sup>10</sup>		
Catégorie <sup>*</sup>	Identification des documents cités, <sup>11</sup> avec indication, si nécessaire, des passages pertinents <sup>12</sup>	N° des revendications visées <sup>13</sup>
A	Patent Abstracts of Japan, volume 4, no. 153 (P-33)(635), 25 octobre 1980, & JP, A, 55101803 (BRIDGESTONE TIRE K.K.), 1980 ---	1-6
A	Patent Abstract of Japan, volume 7, no. 212 (P-224)(1357), 20 septembre 1983 & JP, A, 58106405 (SUMITOMO GOMU KOCIO K.K.), 24 juin 1983 ---	1
A	DE, A1, 2900040 (BRIDGESTONE TIRE CO. LTD) 26 juillet 1979 voir revendications 1-12 ---	1-6
A	US, A, 4227308 (A.R. TALANSKY et al.) 14 octobre 1980 voir colonnes 2-4 ---	1-6
<p><sup>*</sup> Catégories spéciales de documents cités: <sup>11</sup></p> <p>« A » document définissant l'état général de la technique, non considéré comme particulièrement pertinent</p> <p>« E » document antérieur, mais publié à la date de dépôt international ou après cette date</p> <p>« L » document pouvant jeter un doute sur une revendication de priorité ou cité pour déterminer la date de publication d'une autre citation ou pour une raison spéciale (telle qu'indiquée)</p> <p>« O » document se référant à une divulgation orale, à un usage, à une exposition ou tous autres moyens</p> <p>« P » document publié avant la date de dépôt international, mais postérieurement à la date de priorité revendiquée</p> <p>« T » document ultérieur publié postérieurement à la date de dépôt international ou à la date de priorité et n'appartenant pas à l'état de la technique pertinent, mais cité pour comprendre le principe ou la théorie constituant la base de l'invention</p> <p>« X » document particulièrement pertinent: l'invention revendiquée ne peut être considérée comme nouvelle ou comme impliquant une activité inventive</p> <p>« Y » document particulièrement pertinent: l'invention revendiquée ne peut être considérée comme impliquant une activité inventive lorsque le document est associé à un ou plusieurs autres documents de même nature, cette combinaison étant évidente pour une personne du métier.</p> <p>« &amp; » document qui fait partie de la même famille de brevets</p>		
<b>IV. CERTIFICATION</b>		
Date à laquelle la recherche internationale a été effectivement achevée	Date d'expédition du présent rapport de recherche internationale	
5 juin 1991	19. 07. 91	
Administration chargée de la recherche internationale OFFICE EUROPEEN DES BREVETS	Signature du fonctionnaire autorisé:  Mme Dagmar FRANK	

III. DOCUMENTS CONSIDÉRÉS COMME PERTINENTS		(SUITE DES RENSEIGNEMENTS INDICUÉS SUR LA DEUXIÈME FEUILLE)
Catégorie *	Identification des documents cités, avec indication, si nécessaire, des passages pertinents	N° des revendications visées
A	US, A, 3170243 (S.T. WILLIAMS) 23 février 1965 voir revendications 1-6 ---	1
A	GB, A, 2220491 (HSI-KUANG WENG) 10 janvier 1990 voir revendications 1-3 ---	1
A	GB, A, 2219401 (H.K. WENG) 6 décembre 1989 voir revendications 1-4 -----	1

ANNEXE AU RAPPORT DE RECHERCHE INTERNATIONALE  
RELATIF A LA DEMANDE INTERNATIONALE NO.

FR 9100221  
SA 46261

La présente annexe indique les membres de la famille de brevets relatifs aux documents brevets cités dans le rapport de recherche internationale visé ci-dessus.  
Lesdits membres sont contenus au fichier informatique de l'Office européen des brevets à la date du 16/07/91  
Les renseignements fournis sont donnés à titre indicatif et n'engagent pas la responsabilité de l'Office européen des brevets.

Document brevet cité au rapport de recherche	Date de publication	Membre(s) de la famille de brevet(s)	Date de publication
DE-A- 2900040	26-07-79	JP-A- 54099662 US-A- 4195413	06-08-79 01-04-80
US-A- 4227308	14-10-80	Aucun	
US-A- 3170243		Aucun	
GB-A- 2220491	10-01-90	DE-A- 3827456	15-02-90
GB-A- 2219401	06-12-89	US-A- 4884175	28-11-89

FFO FORM 10472

Pour tout renseignement concernant cette annexe : voir Journal Officiel de l'Office européen des brevets, No.12/82