



(11) **EP 1 329 003 B1**

(12) **EUROPEAN PATENT SPECIFICATION**

(45) Date of publication and mention of the grant of the patent:  
**14.12.2011 Bulletin 2011/50**

(21) Application number: **01986374.5**

(22) Date of filing: **01.10.2001**

(51) Int Cl.:  
**H01R 13/428 (2006.01)**

(86) International application number:  
**PCT/EP2001/011334**

(87) International publication number:  
**WO 2002/029936 (11.04.2002 Gazette 2002/15)**

(54) **ELECTRICAL CONNECTOR MODULE WITH HOUSINGS FOR RECEIVING FORWARDLY-INSERTED FEMALE CONTACTS**

ELEKTRISCHES VERBINDERMODUL MIT GEHÄUSEN ZUR AUFNAHME VORWÄRTS EINGEFÜHRTER BUCHSENKONTAKTE

MODULE CONNECTEUR ELECTRIQUE COMPRENANT DES BOITIERS DESTINES A RECEVOIR DES CONTACTS FEMELLES INTRODUIITS VERS L'AVANT

(84) Designated Contracting States:  
**AT BE CH CY DE DK ES FI FR GB GR IE IT LI LU MC NL PT SE TR**

(30) Priority: **02.10.2000 FR 0012538**

(43) Date of publication of application:  
**23.07.2003 Bulletin 2003/30**

(73) Proprietor: **FCI Automotive Holding**  
**78280 Guyancourt (FR)**

(72) Inventors:  
• **GODEFROY, Alban**  
**F-28230 Epernon (FR)**

- **CASSES, Claude**  
**F-28300 Clevilliers (FR)**
- **CAPPE, Patrice**  
**F-28210 Faverolles (FR)**

(74) Representative: **Regi, François-Xavier**  
**FCI - IP Department**  
**18 Parc Ariane III**  
**3/5 rue Alfred Kastler**  
**78284 Guyancourt Cedex (FR)**

(56) References cited:  
**FR-A- 2 036 751 FR-A- 2 386 961**  
**US-A- 3 853 389**

**EP 1 329 003 B1**

Note: Within nine months of the publication of the mention of the grant of the European patent in the European Patent Bulletin, any person may give notice to the European Patent Office of opposition to that patent, in accordance with the Implementing Regulations. Notice of opposition shall not be deemed to have been filed until the opposition fee has been paid. (Art. 99(1) European Patent Convention).

## Description

**[0001]** The present invention concerns an electrical connector module with housings for receiving forwardly-inserted contacts. These contacts are female contacts.

**[0002]** This electrical connector module is also adapted to be introduced into a module-carrier.

**[0003]** The female contacts comprise a body with a cage at the front and a blade at the rear. This blade carries pins to be crimped on the flexible circuit.

**[0004]** This module is equipped with a moveable flap, known generally but described according to a preferred embodiment in a related application in the name of the same applicant. Such a flap assures a mechanical blockage of the flexible circuit so as to prevent its tearing away perpendicular to the crimpings during inadvertent pulling forces exerted not only on the connector but also on the cables themselves. This flap also prevents peeling, that is to say delaminating of the sheets constituting the flexible circuit, as well as transmission of undulations via the flexible circuit, which would also tend to damage the crimpings.

**[0005]** During operation of the connector assembly, this flap is advantageously arranged to assume three fully-defined angular positions, one being as manufactured for insertion of the contacts, another being a delivery position for insertion of the flexible circuit into the modules, and the last, completely lowered, being closure of the flap effected simultaneously with the operation of seating the flexible circuit on the blades of the contacts.

**[0006]** The flexible circuits described above, more generally designated "flex" in the connector field, are sheets formed of a complex of layers of insulating material between which are built up wiring lines of conductive material constituting both conductors and contacts for these circuits.

**[0007]** These conductive wiring lines are protected and electrically insulated. Such flexible circuits are used in the case of multiple contacts to be disposed in a small clearance, and to be rejoined at the point of exist as they were upon arrival.

**[0008]** The width and thickness of the wiring lines determines the conductive capacity, which in turn leads to dispose, on a same flexible circuit and in a same connector, contacts of varying dimensions. Nevertheless, for purposes of simplifying the present description, the wiring lines and contacts have the same dimensions.

**[0009]** The numerous advantages of these flexible circuits have led designers to use them more and more, especially in the automotive industry.

**[0010]** In practice, the connection of the set of contacts is effected in a single operation, by seating after insertion of the flexible circuit into the connector. Generally, locking means assure in a complementary manner the mechanical retention of the sheet in the said connector.

**[0011]** US Patent 4317609 describes an electrical connector module comprising housings each for receiving a female contact, each female contact comprising bosses

for immobilizing and preventing gap, by exerting forces perpendicular to the wall of the said housing.

**[0012]** There remains the problem of inserting the contacts into the module and the present invention proposes an appropriate response by resorting to an arrangement which permits insertion of the contacts forwardly with a locking that prevents the retraction of each of these contacts out of their housing.

**[0013]** To that end, the electrical connector module comprises housings for receiving forwardly introduced contacts, and is characterized in that each housing has the shape of a truncated pyramid with a clearance angle, and in that each contact comprises bosses on the cage for immobilization and suppression of gap.

**[0014]** There is also provided at least one retention catch so as to assure an immobilization in the forward/reverse direction.

**[0015]** This module according to the present invention is also adapted to be introduced into a module-carrier, and it comprises to that end snap-locking means.

**[0016]** The present invention will now be described with reference to the accompanying drawings, which correspond to a preferred but non-limiting embodiment, with reference to the accompanying drawings, which show:

- Figure 1, a perspective view of an electrical connector module according to the present invention,
- Figure 2, a perspective view partially broken-away of this same module,
- Figure 3A, a perspective view of a contact provided with retaining means,
- Figure 3B, a perspective view of a contact of greater width,
- Figures 4A and 4B, a sectional view of a housing receiving a contact provided with retaining means and a sectional view but in a perpendicular plane, and,
- Figure 5, a perspective view of a module according to the present invention inserted into a module-carrier.

**[0017]** In Figure 1, there is shown the contact-carrying electrical connector module 10, as well as a flexible circuit 12 about to be mounted.

**[0018]** The module 10 comprises a body 14 with housings 16 adapted to receive contacts 18, in this case female contacts.

**[0019]** Each contact 18 comprises a forward portion forming a cage 20, a transitional zone 22, and a rear blade 24, provided with pins 26 to be crimped, as is best seen in Figures 2, 3A and 3B.

**[0020]** The preferred embodiment of this module body is described in a detailed manner in a related application in the name of the same applicant.

**[0021]** Apart from the body 12, an important component is the means for restraining the flexible circuit, which comprise a flap 28, which pivots about an axis 30, with a tongue/groove assembly 32 adapted to generate an

offset portion in the flexible circuit and to mechanically immobilize this latter upon lowering the flap. Such a position is shown in detail in Figure 5.

[0022] It will be noted that this flap comprises a window 34 which permits assuring the crimping of the pins on the flexible circuit, simultaneous to the lowering motion of the flap, through the said window. This crimping is obtained by means of a tool adapted to the type of pins, and whose manufacture is within the capability of the skilled artisan.

[0023] The problem of mounting the contacts 18 in the housing 16 is solved by characteristics of the contact and characteristics of the housing.

[0024] Specifically, the housing 16 has the shape of a truncated pyramid, with a clearance angle of slight slope, on two opposed faces among the four faces.

[0025] The large base is the inlet for connection of the housing and this housing narrows from the front to the rear.

[0026] Moreover, each cage 20 of each female contact 18 is provided with bosses 36 which come to bear on the walls in facing relation of this housing with a clearance angle as is shown in the section of Figure 4A. Consequently, the bosses 36 are present facing and perpendicularly bearing on non-parallel walls.

[0027] Moreover, this same cage carries at least one retention catch 38, disposed in the perpendicular plane and visible in Figure 4B. Each catch is dimensioned and disposed so as to cooperate with the wall 40 of the housing when the contact is completely inserted. In this case, the catches come into contact on the two opposing surfaces, other than those facing the bosses 36. The two surfaces receiving the catches 38 are parallel. The number of catches is variable as a function of the type of contact and for a contact of large dimensions, as shown in Figure 3B, it is suitable to provide two pairs.

[0028] In the preferred embodiment, the catches are disposed at the rear of the cage 20, whereas the bosses are positioned forwardly.

[0029] The contact is thus immobilized, without gap, in the housing via support on the walls of this housing in the transverse direction and by coupling in the direction of forward/reverse retraction. The bosses 36 also participate in retaining the contact in its housing.

[0030] It is specifically necessary that the contact be maintained in its housing up to the crimping operation.

[0031] For the security of the retention, it is provided to dispose an abutment 41 rearwardly of each contact. The contact is lodged in the housing upstream of this abutment by the relative dimensions of the contact and of the housing. Thus, when a pulling force might be exerted on the contact, the contact is forced rearwardly into the housing up to the abutment, the resisting force being calculated to safeguard the integrity of the electrical connection until abutment occurs.

[0032] Once the module 10 is itself inserted into a module-carrier 42, it is verified that the contacts 18 also remain accessible from the front, so as to permit the con-

nection. It is thus necessary to retain these contacts in their respective housings, at the level of the module, during disconnection or during an accidental pulling force on the module carrier.

5 [0033] The module and the module carrier are equipped with means 44 for snap-locking of the module into the module-carrier. In Figure 1, only one of the two elastic locks is visible, each provided to cooperate with an opening arranged in the module-carrier.

10 [0034] It will also be noted that the shape with clearance angle of the housing permits generating a progressive insertion force of the contact into the housing during its positioning. Moreover, after complete insertion, each contact is force-fitted such that no gap remains, contrary to the mountings of the prior art.

15 [0035] There nevertheless remains a safeguard in the case of significant pulling force prior to coming in contact with the abutment 41.

20 [0036] In the case of a substantial pulling force, the module is forcibly extracted from the module-carrier and it is this connection which serves as the weak link to safeguard the electrical connection, even if the locking by the tongue/groove on the flexible circuit would be insufficient.

25 [0037] Such an arrangement permits facilitating the mounting of contacts on the one hand, while safeguarding the electrical connection even in the case of a substantial pulling force, on the other hand.

### 30 Claims

1. Electrical connector module comprising housings (16) each receiving a female contact (18) adapted to be connected to a flexible circuit, each female contact (18) comprises a cage (20) which carries bosses (36) disposed at a first end of the cage (20) for immobilizing and preventing gap, by exerting forces perpendicular to the wall of the said housing, whereby each female contact (18) further comprises at least one retention catch (38) so as to assure an immobilization in the forward/reverse direction in the housing, the at least one retention catch (38) being longitudinally spaced from the bosses along the length of the cage at a second opposite end of the cage.
2. Electrical connector module according to claim 1, **characterised in that** each housing (16) has the shape of a truncated pyramid with a clearance angle.
3. Electrical connector module according to claim 2, **characterised in that** the truncated pyramid shape of each housing (16) is at a slight clearance angle on only two opposite surfaces which receive the immobilization bosses (36).
4. Electrical connector module according to claim 3, **characterised in that** each retention catch (38) is

disposed facing parallel opposing surfaces of each housing.

5. Electrical connector module according to claim 4, **characterized in that** each retention catch (38) is disposed downstream of the said contact.
6. Electrical connector module according to claim 3 to 5, **characterized in that** each female contact (18) comprises in addition to the forward cage (20), a rear blade (24), provided with pins (26) to be seated on a flexible circuit (12) and means (32) for retaining the flexible circuit (12) when the pins (26) are seated on the flexible circuit.
7. Electrical connector module according to claim 6, **characterized in that** the retaining means (32) comprise a flap (28) which is pivotable about an axis (30) with a tongue/groove assembly (32) adapted to generate an offset portion in the flexible circuit (12) and to immobilize this latter upon lowering the flap (28).
8. Electrical connector module according to claim any one of the preceding claims, **characterized in that** it comprises means (44) for snap-locking in a module-carrier.

#### Patentansprüche

1. Elektrisches Steckverbindermodul aufweisend Sitze (16) jeder für die Aufnahme von Kontakthülsen (18), geeignet um an einen flexiblen Bandleiter angeschlossen zu werden, wobei jede Kontakthülse (18) eine Hülse (20) aufweist, die Wülste (36) trägt, die an einem ersten Ende der Hülse (20) angeordnet sind und die Spiel blockieren und beseitigen dadurch, dass sie Kräfte ausüben senkrecht zu der Wand des besagten Sitzes, wobei jede Kontakthülse (18) weiter zumindest eine Rückhaltenase (38) aufweist um im Sitz eine Blockierung in der Richtung nach vorne / nach hinten zu gewährleisten, wobei die zumindest eine Rückhaltenase (38) in Längsrichtung beabstandet ist von den Wülsten entlang der Länge der Hülse an einem zweiten gegenüberliegenden Ende der Hülse.
2. Elektrisches Steckverbindermodul gemäß Anspruch 1, **dadurch gekennzeichnet, dass** jeder Sitz (16) die Form einer stumpfen Pyramide mit einem Freiwinkel hat.
3. Elektrisches Steckverbindermodul gemäß Anspruch 2, **dadurch gekennzeichnet, dass** die abgestumpfte Pyramidenform jedes Sitzes (16) einen kleinen Freiwinkel nur an zwei gegenüberliegenden Flächen aufweist, die die Blockierungswülste (36) aufnehmen.

4. Elektrisches Steckverbindermodul gemäß Anspruch 3, **dadurch gekennzeichnet, dass** jede Rückhaltenase (38) gegenüber von parallel gegenüberliegenden Flächen von jedem Sitz angeordnet sind.

5. Elektrisches Steckverbindermodul gemäß Anspruch 4, **gekennzeichnet dadurch, dass** jede Rückhaltenase (38) besagtem Kontakt nachgeschaltet angeordnet ist.

6. Elektrisches Steckverbindermodul gemäß den Ansprüchen 3 bis 5, **dadurch gekennzeichnet, dass** jede Kontakthülse (18) zusätzlich zu der vorderen Hülse (20) eine hintere Fahne (24) aufweist, an der Zähne (26) vorgesehen sind die auf einem flexiblen Bandleiter (12) aufzuklemben sind, sowie Mittel (32) um den flexiblen Bandleiter (12) anflanschen, sobald die Zähne (26) auf diesem flexiblen Bandleiter aufgeklemmt sind.

7. Elektrisches Steckverbindermodul gemäß Anspruch 6, **dadurch gekennzeichnet, dass** die Anflanschmittel (32) aus einer um eine Achse (30) schwenkbaren Klappe (28) mit einer Einheit (32) aus Leiste und Nut bestehen, durch die in dem flexiblen Bandleiter (12) eine Verformung bewirkt wird und diese mechanisch blockiert wird, sobald die Klappe (28) geschlossen ist.

8. Elektrisches Steckverbindermodul nach einem der vorhergehenden Ansprüche, **gekennzeichnet dadurch, dass** es Mittel (44) aufweist, um in einen Modulträger einzurasten.

#### Revendications

1. Module de connecteur électrique comportant des logements (16) chacun pour recevoir un contact femelle (18) adapté pour être connecté à un circuit souple, chaque contact femelle (18) comprend une cage (20) qui porte des renflements (36) disposés à une première extrémité de la cage (20) pour immobiliser et prévenir le jeu, en exerçant des forces perpendiculaires à la paroi dudit logement et dans lequel chaque contact femelle (18) comprend en outre un ergot de retenu (38) pour assurer une immobilisation dans le sens arrière/avant dans le logement, le au moins un ergot de retenu (38) étant espacé longitudinalement des renflements le long de la cage à une seconde extrémité de la cage.
2. Module de connecteur électrique selon la revendication 1, **caractérisé en ce que** chaque logement (16) a la forme d'une pyramide tronquée comportant un angle de dépouille.
3. Module de connecteur électrique selon la revendication 1, **caractérisé en ce que** chaque logement (16) a la forme d'une pyramide tronquée comportant un angle de dépouille.

- cation 2, **caractérisé en ce que** la forme en pyramide tronquée de chaque logement (16) est à faible angle de dépouille sur seulement les deux faces opposées qui reçoivent les renflements d'immobilisation (36). 5
4. Module de connecteur électrique selon la revendication 3, **caractérisé en ce que** chaque ergot de retenu (38) est disposé en regard de surfaces parallèles opposées de chaque logement. 10
5. Module de connecteur électrique selon la revendication 4, **caractérisé en ce que** chaque ergot de retenu (38) est disposé en aval dudit contact. 15
6. Module de connecteur électrique selon l'une quelconque des revendications 3 à 5, **caractérisé en ce que** chaque contact femelle (18) comprend, en plus de la cage avant (20), une lame à l'arrière (24), munie de picots (26) à sertir sur un circuit souple (12) et des moyens (32) pour retenir le circuit souple (12) une fois que les picots (26) aient été sertis sur le circuit flexible. 20
7. Module de connecteur électrique selon la revendication 6, **caractérisé en ce que** les moyens de retenue (32) comportent un volet (28) qui peut pivoter autour d'un axe (30) ayant un assemblage languette / rainure (32) adapté pour générer une partie décalée dans le circuit souple (12) et pour immobiliser ce dernier une fois que volet (28) ait été rabattu. 25 30
8. Module de connecteur électrique selon l'une quelconque des revendications précédentes, **caractérisé en ce qu'il** comporte des moyens (44) d'encliquetage dans un porte-module. 35

40

45

50

55

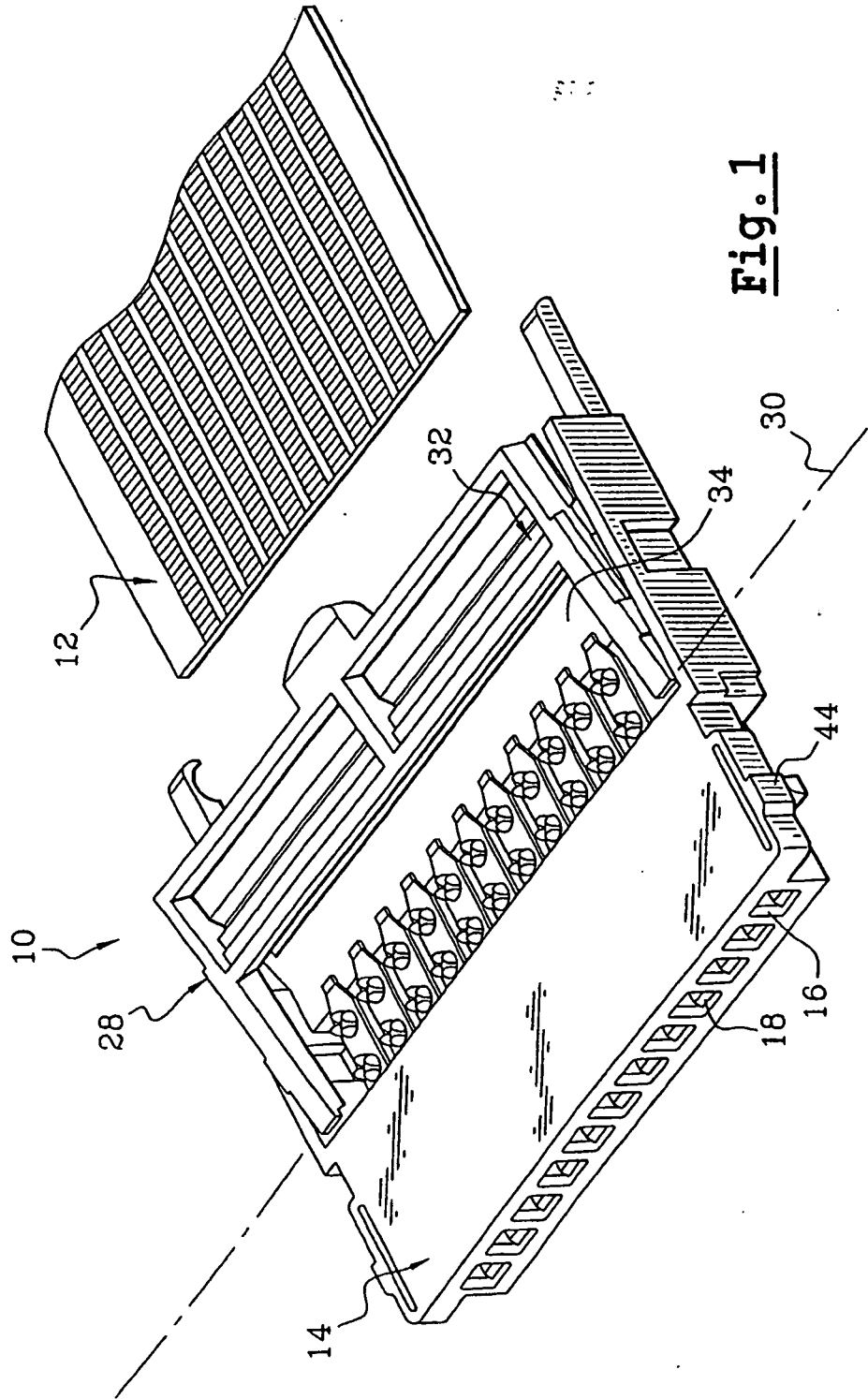

**Fig. 1**

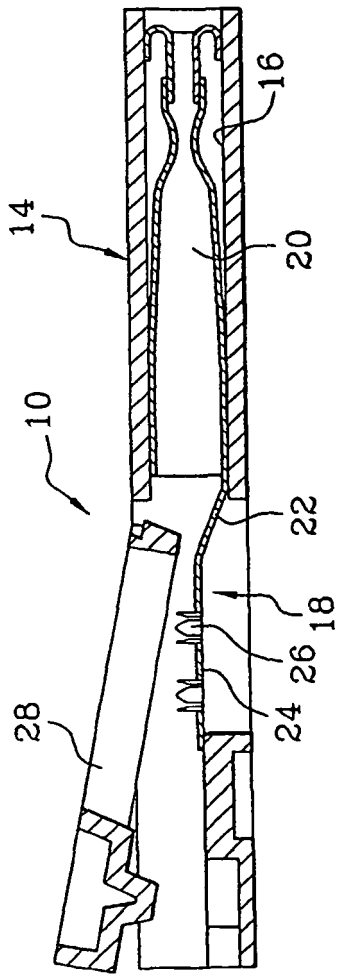

Fig. 2

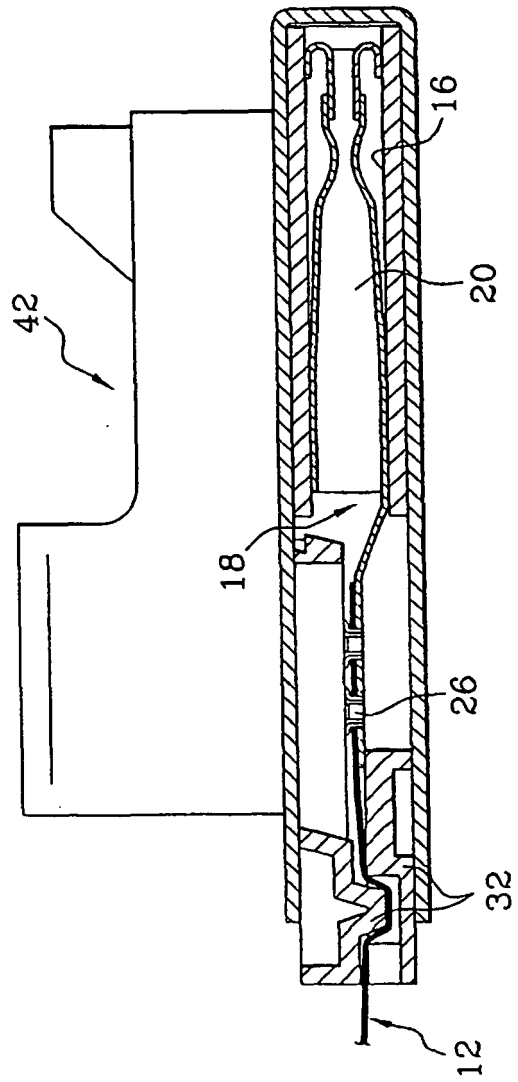

Fig. 5

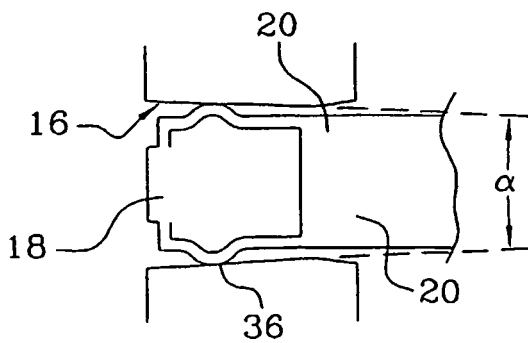
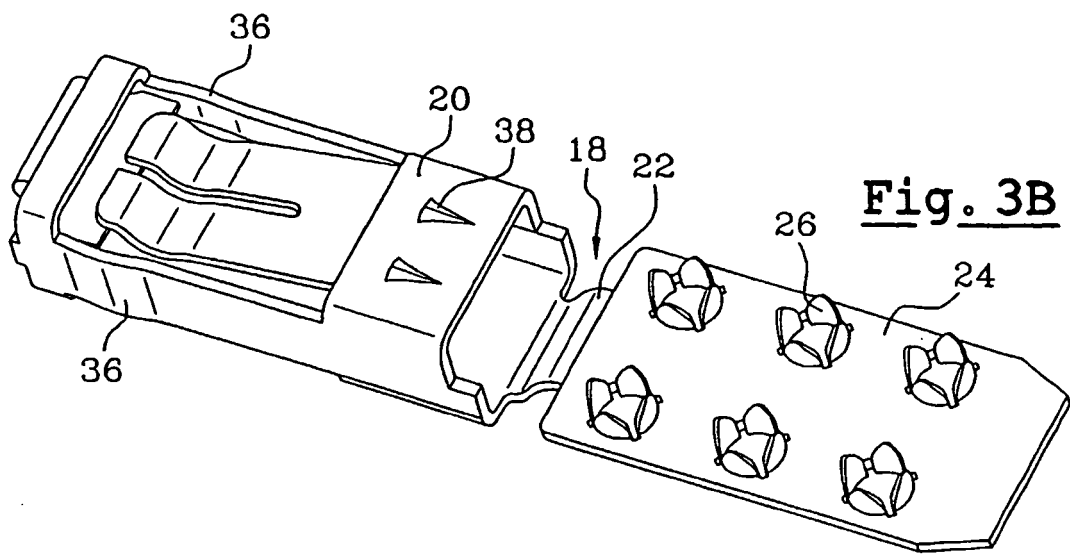
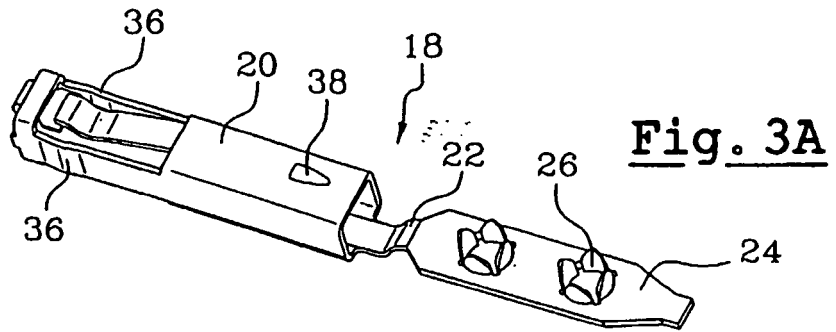

Fig. 4A

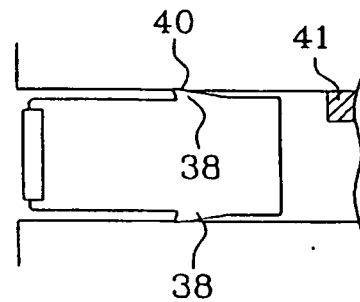

Fig. 4B

**REFERENCES CITED IN THE DESCRIPTION**

*This list of references cited by the applicant is for the reader's convenience only. It does not form part of the European patent document. Even though great care has been taken in compiling the references, errors or omissions cannot be excluded and the EPO disclaims all liability in this regard.*

**Patent documents cited in the description**

- US 4317609 A [0011]