



INTERNATIONAL APPLICATION PUBLISHED UNDER THE PATENT COOPERATION TREATY (PCT)

<p>(51) International Patent Classification ⁶ : B65D 81/18, 81/26</p>	<p>A1</p>	<p>(11) International Publication Number: WO 97/30909 (43) International Publication Date: 28 August 1997 (28.08.97)</p>
<p>(21) International Application Number: PCT/AU97/00086 (22) International Filing Date: 19 February 1997 (19.02.97) (30) Priority Data: PN 8248 22 February 1996 (22.02.96) AU PN 8949 27 March 1996 (27.03.96) AU (71) Applicant (for all designated States except US): THERMA RITE PTY. LTD. [AU/AU]; Suite 2, 8 Sixth Avenue, Palm Beach, QLD 4221 (AU). (72) Inventor; and (75) Inventor/Applicant (for US only): DARNETT, Rodney [AU/AU]; Suite 2, 8 Sixth Avenue, Palm Beach, QLD 4221 (AU). (74) Agent: CULLEN & CO.; Level 12, 240 Queen Street, Brisbane, QLD 4000 (AU).</p>	<p>(81) Designated States: AL, AM, AT, AU, AZ, BA, BB, BG, BR, BY, CA, CH, CN, CU, CZ, DE, DK, EE, ES, FI, GB, GE, HU, IL, IS, JP, KE, KG, KP, KR, KZ, LC, LK, LR, LS, LT, LU, LV, MD, MG, MK, MN, MW, MX, NO, NZ, PL, PT, RO, RU, SD, SE, SG, SI, SK, TJ, TM, TR, TT, UA, UG, US, UZ, VN, YU, ARIPO patent (KE, LS, MW, SD, SZ, UG), Eurasian patent (AM, AZ, BY, KG, KZ, MD, RU, TJ, TM), European patent (AT, BE, CH, DE, DK, ES, FI, FR, GB, GR, IE, IT, LU, MC, NL, PT, SE), OAPI patent (BF, BJ, CF, CG, CI, CM, GA, GN, ML, MR, NE, SN, TD, TG). Published <i>With international search report.</i></p>	

(54) Title: AN ABSORBENT PAD

(57) Abstract

An absorbent pad has a top sheet and a bottom sheet, the sheets being joined to form at least one cell, an absorbent located within the cell, at least one sheet being formed of a liquid impermeable material containing microperforations. The top and/or bottom sheets may comprise multiple layers of different materials, e.g., plastics, non-woven fabrics, paper.

a

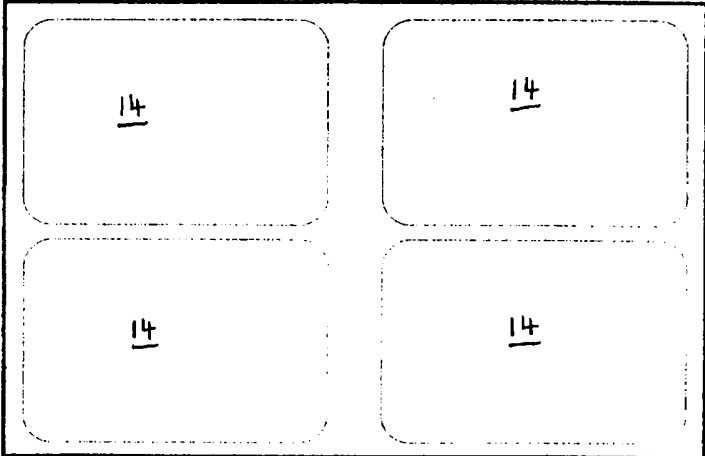

b

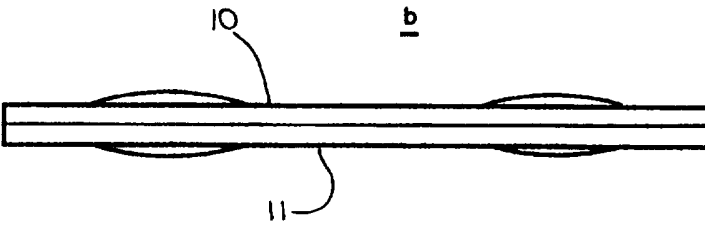

FOR THE PURPOSES OF INFORMATION ONLY

Codes used to identify States party to the PCT on the front pages of pamphlets publishing international applications under the PCT.

AM	Armenia	GB	United Kingdom	MW	Malawi
AT	Austria	GE	Georgia	MX	Mexico
AU	Australia	GN	Guinea	NE	Niger
BB	Barbados	GR	Greece	NL	Netherlands
BE	Belgium	HU	Hungary	NO	Norway
BF	Burkina Faso	IE	Ireland	NZ	New Zealand
BG	Bulgaria	IT	Italy	PL	Poland
BJ	Benin	JP	Japan	PT	Portugal
BR	Brazil	KE	Kenya	RO	Romania
BY	Belarus	KG	Kyrgystan	RU	Russian Federation
CA	Canada	KP	Democratic People's Republic of Korea	SD	Sudan
CF	Central African Republic	KR	Republic of Korea	SE	Sweden
CG	Congo	KZ	Kazakhstan	SG	Singapore
CH	Switzerland	LI	Liechtenstein	SI	Slovenia
CI	Côte d'Ivoire	LK	Sri Lanka	SK	Slovakia
CM	Cameroon	LR	Liberia	SN	Senegal
CN	China	LT	Lithuania	SZ	Swaziland
CS	Czechoslovakia	LU	Luxembourg	TD	Chad
CZ	Czech Republic	LV	Latvia	TG	Togo
DE	Germany	MC	Monaco	TJ	Tajikistan
DK	Denmark	MD	Republic of Moldova	TT	Trinidad and Tobago
EE	Estonia	MG	Madagascar	UA	Ukraine
ES	Spain	ML	Mali	UG	Uganda
FI	Finland	MN	Mongolia	US	United States of America
FR	France	MR	Mauritania	UZ	Uzbekistan
GA	Gabon			VN	Viet Nam

TITLE

AN ABSORBENT PAD

FIELD OF THE INVENTION

This invention relates to an absorbent pad and particularly to an absorbent pad for use in the food industry as a biofluid absorbent, or for a cooling pad.

BACKGROUND ART

Absorbent pads are well-known and widely used in the food industry. One type of absorbent pad is used as a biofluid absorber and is placed between fresh meat and the plastic meat tray. The pad functions to absorb biofluids exuding from the meat.

A second type of known pad is used as a cooling pad and is initially swelled with water, frozen and then placed with food or other produce which is to be kept cool.

Both types of pads have internal absorbents and typically use superabsorbent polymers (SAP). These polymers are also well-known and a typical polymer is a cross-linked sodium polyacrylate. In order to allow the internal absorbent to absorb fluid efficiently, the polymer is usually finely ground.

The internal superabsorbent polymer creates some difficulties which must be overcome if the pad is to be safe and commercially successful. Firstly, it is necessary to ensure that the polymer stays within the pad at all times, even when swollen into a gel-like state. Another problem with the superabsorbent polymers is that they are aggressive fluid absorbers and tend to desiccate the meat product by absorbing more than just the exuded biofluids.

To overcome the aggressive absorbing nature of the polymer, it is known to have absorbent pads formed with a bottom wall which is water permeable (and is typically a non-woven fabric), and a top wall formed from a totally liquid impermeable sheet.

A disadvantage with having a liquid impermeable top sheet is that biofluids run over the top sheet and

fall away from the pad without the pad being able to absorb the biofluid through the bottom layer. This is particularly so if the meat product tray is stored or presented at an angle. Another disadvantage with the impervious top layer is that if the meat tray is level, biofluids can pool on the top layer and ruin the meat by promotion of bacterial growth.

Attempts have been made to provide a large slit or a number of slits in the top wall of the pad to overcome the above disadvantage. However the biofluids are still not efficiently absorbed and have a tendency to run off the top sheet, or to pool.

Another problem with cooling pads is that when the pads are swollen with water, the superabsorbent polymer turns into a gel and exerts considerable pressure on the wall of the pad and can extrude through the pad wall. This is particularly so if the top wall of the pad is formed with a large slit or slits.

OBJECT OF THE INVENTION

The present invention has been developed to provide an absorbent pad which can be used both as a biofluid absorber and also as a cooling pad and which can at least reduce the abovementioned disadvantages or provide the public with a useful or commercial choice.

In one form, the invention resides in an absorbent pad which has a top sheet and a bottom sheet, the sheets being joined to form at least one cell, a absorbent located within the cell, characterised in that at least one of the sheets is formed from a liquid impermeable material containing microperforations to allow fluid to pass through the microperforations and into the cell.

It is preferred that the top sheet is formed from the microperforated material. The bottom sheet may be formed from similar material, or different material such as a water permeable non-woven sheet, a paper sheet, or a totally water impermeable sheet.

We find that the microperforations temper the

aggressiveness of the superabsorbent polymer within the cell or cells. That is, the microperforations minimise the drawing effect which results in undesired desiccation of the meat product. The drawing effect appears to be
5 minimised to an acceptable level by having a large number of extremely small perforations in the sheet of the absorbent pad which can then be placed under the meat product.

The microperforations also appear to reduce or
10 prevent pooling of biofluids on top of the absorbent pad and if the microperforations are spread over the top sheet of the absorbent pad, biofluid absorption can occur over a larger surface area than might be the case if the pad was only slotted or slitted.

The microperforations are typically spread over
15 the sheet in a substantially homogenous fashion. It is however envisaged that parts of the sheet may not include microperforations and these parts may include the joints between adjacent cells.

The microperforations may have various shapes
20 and sizes and may be circular, elliptical (cigar-shaped), polygonal (including rectangular, triangular and diamond-shaped), irregular and the like. Depending on the process used to perforate the sheet, the formed perforations may
25 have a flap or hinge portion adjacent the formed hole which still allows liquids to pass through the perforations.

The microperforations can be formed by hot pin
30 perforating, cold pin perforating, open flame perforating, laser perforating, and by other suitable techniques. The different perforating processes may form different hole sizes and shapes.

A typical size of the microperforation can be
35 between 10 to 200 microns. For instance, if the perforation is elliptical, it may have a size of approximately 20 microns X 90 microns, but this can vary between 10 microns and 200 microns, possibly even more, the larger size being determined by the aggressiveness of

the absorbing polymer or other type of absorbent.

The number of microperforations in the sheet may also vary as can be regularity or irregularity of the microperforations. There may be provided between 10 to
5 500 microperforations per square inch and we find a microperforation number of 330 per square inch to be suitable for our purposes. We find that the number of holes per square inch appears to affects only the absorption rate of the product.

10 The size of the absorbent pad itself can also vary depending on its use. We find that a typical pad may be about 400mm across and have an unlimited length with the consumer able to simply cut the pad lengthwise to suit. Each pad may have one or more cells, and we
15 find that for a pad having a width of 400mm, there may be provided 6 or so cells. Each cell can be of any shape or size and we find a suitable size to be between 40mm to 100mm across.

The sheet containing the microperforations
20 (which is typically the top sheet), can be formed from a plastic film. The plastic film can be a single film, a laminate film or other types of film. One type of useful film is a laminate formed from a polyester and a polyethylene. We find a suitable thickness to be a 12
25 micron polyester film laminated to a 30 micron polyethylene film. Other film thickness can be used if desired. We find that other types of plastics can be used such as nylon, other types of polyene film such as all types of polyethylenes and polypropylenes. We also
30 find use for polyurethane and polyvinyl films. We find that the main property desired from the film is that it is able to be strong enough to resist wear and tear during use. We also find it desirable to choose a film which can accept printing inks such that the sheets of
35 the pad, or at least one sheet of the pad, can be printed. We find it desirable from a consumer point of view that the films have a good opacity. If we form the pad by heat sealing the top sheet and the bottom sheet

together, we prefer the films to be heat sealable.

If the absorbent pad contains a microperforated top sheet and a different type of bottom sheet, one type of preferred bottom sheet is a non-woven fabric. Many types of non-woven fabrics are known in the art, and a suitable fabric is a 40g per square metre bi-component continuous filament which is pressure and temperature bonded. The filament can be made of a polyester core with a polyethylene sheath and this type of material is known. The filament may comprise a different type of sheath plastic such as polypropylene or a polypropylene polyethylene co-polymer. These filaments are desirable because a strong heat seal can be formed in the non-woven fabric. These non-woven fabrics have a good random distribution of the fibres to ensure that the pore size or holes in the fabric are small enough to prevent polymer from being shaken out of the pad, and also to prevent the swollen hydrated polymer from squeezing through the fabric.

It should be appreciated that there are many types of non-woven fabrics available in the marketplace which could fulfil our requirements.

If the top sheet is microperforated, we may desire to have the bottom sheet totally liquid impermeable and this type of sheet may be formed from any type of suitable water impermeable plastic film, or other type of film which may be available from time to time.

In order to reduce the possibility of absorbent egress from the cells in the pad, a further barrier sheet can be provided below the microperforated sheet. The barrier sheet is preferably of the type that will allow fluid to pass or wick through the sheet but will act as a barrier for the absorbent. Various types of papers can be used as the barrier sheet.

In a further variation, the top sheet may comprise a preformed multi-layer sheet composite. For instance, the top sheet can comprise an outermost microperforated sheet, an intermediate barrier sheet and

an innermost microperforated sheet to form a triple layer sheet composite. This multi-layer sheet can form the top sheet and/or the bottom sheet of the absorbent pad.

In order to strengthen the microperforated sheet, a further reinforcement sheet may be provided. Occasionally, it is found that the pressure inside the absorbent pad is such that it can place an undesirable amount of strain on the microperforated sheet. This sheet, is weakened by having the microperforations in it, and there is a possibility that the microperforated sheet can tear or split. For instance, when the pad is used as an ice replacement pad, it is swollen with water and then frozen. The swelling and freezing creates considerable pressure within the pad. It is common to provide a flexible sheet having a number of absorbent cells within it. The flexible sheet can be swollen with water, frozen and then wrapped around the product which is to be kept cool. It is found that when the product is frozen, the microperforated sheet can approach its cold flex temperature which means that the film resists flexing and is susceptible to formation of cracks and tears.

For this reason, the absorbent pad can include the reinforcement sheet. The reinforcement sheet may be positioned behind the microperforated sheet. It is preferred that the reinforcement sheet does not appreciably prevent fluid from passing into the absorbent. Therefore, a preferred reinforcement sheet is a non-woven fabric, or a microperforated film.

The absorbent in the cell of the pad may comprise a single type of absorbent or mixture. Although many types of absorbents are known and used in absorbent pads, we find it desirable to use a superabsorbent polymer, as such polymers can absorb many times their weight in liquid, and although these polymers are aggressive absorbers, we have overcome or tempered this undesirable feature by using the microperforations.

A desired type of superabsorbent polymer include the family of sodium polyacrylates which are

sodium salts of cross-linked polyacrylic acid/polyalcohol grafted co-polymers. These polymers are known and are also known for their use in absorbent pads. Other types of absorbents which we find useful are the sodium carboxy methyl celluloses and these can be cross-linked with a number of different types of aluminium compounds to improve their gel strength qualities. Of course, other types of absorbents can be used with our microperforated pad.

We find that the commercial superabsorbent polymers come in two distinct shapes. The most common types of shape is an irregular granular or gravel shape, while the other shape is a more rounded spherical configuration.

We also find that the commercial superabsorbent polymers have varying particle sizes and typical particle sizes are as follows -

	850 micron and above:	0 - 2%
	850 - 600 microns:	24 - 32%
20	600 - 500 microns:	20 - 28%
	500 - 300 microns:	32 - 40%
	300 - 180 microns:	4 - 12%
	180 - 90 microns:	0 - 4%
	90 - 45 microns:	0 - 2%
25	45 microns and below:	0 - 0.1%

Different batches of polymer can have different size ranges and size extremes such as up to or even above 2000 microns, and it will be appreciated that we can adjust our microperforation shape and size to compliment that of the absorbent we use in the cells to minimise or at least reduce undesirable loss of absorbent through the cell wall.

The amount of absorbent we use can of course vary depending upon the absorbent capacity and rate and depending upon how much liquid we wish to absorb. A typical superabsorbent polymer will absorb anywhere between 100g to 500g of tap water per gram of polymer.

We prefer that the polymer dosage in the cell

is such that the polymer is able to fully hydrate and is not prevented from full hydration. For this reason, we prefer that not too much polymer is added in each cell. We find that when our pad is used as a cooling pad, consumers do not wish to believe that the cooling pad will absorb any other liquids from the surrounding area, and instead will only function as a cooling pad. For this reason, we like to ensure that the polymer can be fully hydrated before freezing if it is used as a cooling pad.

The pad itself can be formed in a number of different ways. One preferred way, and a way which has been used in other known pads, is to heat seal the top sheet and bottom sheet together. For this reason, we prefer that the top sheet and bottom sheet are formed from heat meltable materials, and these materials are known. Of course, we may also wish to simply glue the sheets together, or attach them by other means.

BRIEF DESCRIPTION OF THE FIGURES

Embodiments of the pad will be described with reference to the following drawings in which

Figures 1A and 1B illustrate a fluid absorbing pad having a top sheet and a bottom sheet both being microperforated.

Figures 2A and 2B illustrate a fluid absorbing pad having a top microperforated sheet and a bottom non-woven fabric sheet.

Figures 3A and 3B illustrate a fluid absorbing pad having a top microperforated sheet and a bottom paper sheet.

Figures 4A and 4B illustrate a cooling pad having a top sheet and a bottom sheet both being microperforated.

Figures 5A and 5B illustrate a cooling pad having a top sheet which is microperforated and a water impervious bottom sheet.

Figures 6A and 6B illustrate a cooling pad having a top sheet which is microperforated and a bottom

sheet formed from a non-woven fabric.

Figures 7A and 7B illustrate a fluid absorbing pad having top and bottom sheets which are microperforated and formed from three layers.

5 Figures 8A and 8B illustrate a fluid absorbing pad where the top sheet is microperforated and is formed from three layers and the bottom sheet is a non-woven fabric.

10 Figures 9A and 9B illustrate a fluid absorbing pad where the top sheet is microperforated and is formed from three layers and the bottom sheet is paper.

Figures 10A and 10B illustrate a cooling pad where the top sheet is microperforated and is formed from three layers and the bottom sheet is a non-woven fabric.

15 Figures 11A and 11B illustrate a cooling pad where the top sheet is microperforated and is formed from three layers and the bottom sheet is also formed from three layers.

20 Figures 12A and 12B illustrate a cooling pad where the top sheet is microperforated and is formed from three layers and the bottom sheet is water impervious.

Figures 13A and 13B illustrate a cooling pad where the top sheet is microperforated and is formed from two layers and the bottom sheet is formed from one layer.

25 Figures 14A and 14B illustrate a cooling pad where the top sheet and the bottom sheet are both formed from two layers.

30 Figures 15A and 15B illustrate a fluid absorbing pad where the top sheet and the bottom sheet are formed from two layers being a microperforated layer and an intermediate paper layer.

35 Figures 16A and 16B illustrate a fluid absorbing pad where the top sheet is formed from two layers being a microperforated layer and a paper layer, and the bottom sheet is a non woven fabric.

Figures 17A and 17B illustrate a fluid absorbing pad where the top sheet is formed two layers being a microperforated layer and a paper layer, and the

bottom sheet is a paper.

Figure 18 illustrates a cooling pad where the top sheet and the bottom sheet are both formed from two layers being a microperforated layer and a non woven fabric layer.

Figure 19 illustrates a cooling pad where the top sheet is formed from two layers being a microperforated layer and a non woven fabric layer, and the bottom sheet is a non woven fabric.

Figure 20 illustrates a fluid absorbing pad where the top sheet is formed from two layers being a microperforated plastic co-extruded layer and a non woven fabric layer, and the bottom sheet is formed from two layers of non woven fabric.

BEST MODE

Referring to the figures, there are shown two types of absorbent pads one particularly suitable for absorbing biofluids (the pad of Figures 1 - 3, 7 - 9) and one particularly suitable as a cooling or heating pad (the pad of Figures 4 - 6, 10 - 12). The pads differ in the size of the cells, and the type of bottom sheet; the top sheet of each pad being microperforated.

Referring initially to the pads of Figures 1 - 3, these pads can be used as a red meat or poultry pad and can be positioned between a meat product and the meat tray. These pads find particular use in meat trays which are found for sale in supermarkets, butchers and the like.

The absorbent pad can come in two main sizes and absorption capacities. One type of pad can have an external dimension of 113mm X 169mm with an internal cell size of 50mm X 72.8mm. In each cell is provided 0.48g of Favor Pac 100th superabsorbent powder which is a sodium polyacrylate and is available commercially. The pad has an overall absorption capacity of about 108g of chicken biofluids. The other main size of the absorbing pad is used particularly in the poultry market and this pad has an external measurement of 141mm X 169mm with the

internal cell being 64mm X 72.8mm. 0.75g of the same superabsorbent polymer is placed in each cell giving the pad an absorption capacity of 120g of biofluids.

5 The absorbing pads of Figures 1 - 3 have a top sheet 10 constructed from a plastic laminate film which is a 12 micron polyester film adhered to a 30 micron polyethylene film. The film is microperforated to a perforation rate of 330 perforations per square inch. The perforations are evenly spread through the top sheet,
10 and each perforation is cigar-shaped having a perforation size of 20 micron across X 90 microns along.

Each pad has a number of cells or pouches 14 in which the absorbent is placed. The cells are totally sealed off around their edges by heat sealing or by other
15 means.

The bottom sheet 11 of the absorbent pad of Figure 1 is identical to the top sheet such that this particular pad is microperforated on both sides. In Figure 2, the bottom sheet 12 is a water permeable non-
20 woven fabric, and in Figure 3, the bottom sheet 13 is a heat fusible paper. Other variations are also envisaged.

The pads of Figures 1 - 3, may include as an option one or two light-weight heat fusible paper sheets. The function of these paper sheets is to act as a
25 molecular sieve to stop any polymer migration. The paper sheets have a weight of 16.5g per square metre and are a blend of cellulose fibres and thermo plastic fibres and the sheet is itself commercially available.

In Figure 2, the bottom sheet 12 is a white
30 polyester/viscose fibre blend which is resin bonded and has a low density polyethylene scatter coating on the inside of the product. The fabric has a typical weight of 65g per square metre with a 45g per square metre fibre/binder blend. With the low density polyethylene
35 scatter coating on the inside of the product, we find that the fabric has an adequate thermal bond with other substrates. The non-woven fabric wets out instantaneously and draws liquids into the fabric once

contact has been made and to transport the liquids to the superabsorbent polymer.

In Figure 3, the bottom sheet 13 is a heavier weight heat fusible paper which is a blend of cellulosic and thermo plastic fibre and can have a weight of between 5 - 100g per square metre. Typically, the paper has 22% thermo plastic fibre and 78% cellulose fibre and is resin bonded to have a good wet strength. The paper has a good wetting and wicking action to assist in drawing fluids to the superabsorbent polymer.

Figures 4 - 6 show thermal pads such as cooling pads. The pads again have an array of separate cells 15 in which the absorbent can be placed. In these embodiments, the top sheet 16 of the cooling pad is formed from a material identical to that of the absorbing pads of Figures 1 - 3. In Figure 5, the bottom sheet 17 of the cooling pad is formed from a totally water impermeable plastic or laminated film such that water can only be absorbed through the microperforated top sheet. As we prefer that the polymer in the cell is fully hydrated, we do not find it useful to have any intermediate paper sheet such as found with the absorbent pad, as the paper sheet tends to reduce the bond strength and the cooling pad is under much more strain than the absorbing pad as much more water is absorbed by the polymer in the cooling pad before it is frozen. In Figure 4, the bottom sheet 18 is identical to the top sheet and in Figure 6, the bottom sheet 19 is a non-woven fabric.

Figures 7 - 9 illustrate further embodiments of pads according to the invention. In these embodiments, the top sheet 20 of each pad is itself formed from a triple layer. The triple layer has an outermost sheet which is a microperforated 12 micron polyester film 21. Immediately behind the sheet is a paper sheet 22 which can have a weight of 38g per square metre. Immediately behind paper sheet 22 is a second perforated polyethylene sheet 23 having a thickness of 25 microns. Thus, it can

be seen that top sheet 20 can be seen as a single sheet formed from three layers being two microperforated layers between which is sandwiched a paper layer. In Figure 7, the bottom layer 24 is also formed from an identical composite as the top layer such that the absorbing pad of Figure 7 is formed from two sheets each having a triple layer structure.

The pad of Figure 8 also has a triple layer top sheet 21 - 23, but in this pad, the bottom sheet is made from a non-woven fabric 30.

Figure 9 illustrates a pad where the top sheet is again formed from the triple layer 21 - 23 and the bottom sheet is formed from a heavy weight paper 31.

Figures 10 - 12 show further thermal pads which can be used as cooling pads or heating pads or can be seen as an ice replacement pad (as can the pads of Figures 4 - 6). In the pads illustrated in Figures 10 - 12, the top sheet is again formed from the triple layers 21 - 23 previously described. In Figure 10, the bottom sheet 32A is formed from non-woven fabric. In Figure 11, the bottom sheet 32B is formed from the triple layer structure identical to the top sheet while in Figure 12, the bottom sheet is formed from a non-perforated plastic laminated film 32C.

The triple layered top sheet as illustrated in Figures 7 - 12 has a 12 micron microperforated polyester top sheet which gives the product excellent strength and provides desirable properties under high temperature and pressure when manufacturing the finished goods. This particular sheet can be reverse printed for product description and advertising purposes. The intermediate paper layer acts as an extremely good molecular sieve to negate any unhydrated polymer and hydrated gel migration through the film. We find that the paper can also act as a transporter of fluids through the two microperforated layers and this is done both in the Z axis and the X - Y axis. The intermediate paper layer can have a weight range of between 5g - 100g per square metre as long as it

provides adequate retention of the absorbent powder both in the hydrated and hydrated form. The third layer of the triple layer structure can be a microperforated polyethylene film and this film can be a mixture of low density polyethylene and linear low density polyethylene with a view to being heat sealable to the bottom sheet to form the pad. Of course, and as described above, a number of different films can be used, for instance nylon, all types of polypropylenes, all types of polyethylenes, their mixtures, polyurethanes and polyvinyl resins.

In an embodiment, the triple layer sheet can be formed as follows. Firstly, the three layers are adhesively laminated together and cured. The unperforated cured sheet is run through a microfine perforator and perforated on one side only making sure that the perforation pins do not pass into the intermediate paper layer. The sheet is then turned over and passed through the microfine perforator, and again the perforating pins pass through the topmost layer only and do not pass through the intermediate paper layer. By having the intermediate paper layer intact and unperforated, it functions effectively as a molecular sieve and does not permit migration of polymer through the sheet.

It is noted that when biofluids of water come into contact with the outermost layer of this triple layer sheet, the fluid is drawn into the structure through the microfine perforations by the capillary action of the paper. The perforations on each side of the sheet need not line up and therefore liquid drawn through the three sheets need not adopt a linear path. This appears also to have some benefit in retention of the polymer in the cells.

Referring to Figures 13A and 13B, there is illustrated a cooling pad 70 where the top sheet 71 is formed from a microperforated layer as described previously. Immediately behind the microperforated layer

is a non-woven fabric 72. The non-woven fabric in the embodiment is an ELEVES™ fabric. The fabric is a white non-woven, 40g per square metre, bi-component continuous filament fabric. The bottom sheet 73 is formed from a non-perforated plastic laminated film.

Figures 14A and 14B show a similar structure except that the bottom sheet 75 is identical to the top sheet 76, with both sheets including outermost microperforated laminated plastic films 77A, 77B immediately behind which is a non-woven fabric 78A, 78B, an example of which is ELEVES™ fabric.

The products illustrated in Figures 13A, 13B, 14A and 14B have a reinforcing sheet in the form of the non-woven fabric. The reinforcing sheet gives the microperforated sheet greater support and provides strength to the overall product. As the microperforations do weaken the laminate film, it is possible that when the product is hydrated fully, and the sheet is bent or twisted, the microperforated laminate can crack and tear therefore allowing the perforations to become larger in size and possibly allowing the superabsorbent polymer to pass through the pad. The pressure can be exacerbated by freezing the pad and wrapping sheet containing the frozen pads around articles that need to be kept cool. The already weakened film when cold may approach its cold flex temperature which causes the film to resist flexing and forcibly wrapping the film around articles can create cracks and tears. The ELEVES™ has a non-woven design which can substantially contain the polymer should cracking or tearing of the microperforated layer still occur.

Figures 15A and 15B illustrate a fluid absorbent pad 40 having four cells 41 (the number of cells being optional). The pad is formed from a top sheet and a bottom sheet. The top sheet is formed from two layers being a microperforated plastic laminate sheet 42 immediately behind which is an intermediate paper sheet 43. The bottom sheet is formed from the same two

layers being an outer microperforated plastic laminate sheet 44 and an intermediate paper sheet 45.

5 Figures 16A and 16B show a pad 45 having four cells 46. The pad is a fluid absorbing pad having a top sheet formed from two layers being an outer microperforated plastic laminate sheet 47 and an intermediate paper sheet 48. In this pad, the bottom sheet 49 is formed from one layer of non-woven fabric.

10 Figures 17A and 17B show a fluid absorbing pad 50 having four cells 51. The top sheet is formed from two layers being an outermost microperforated plastic laminate sheet 52 and an intermediate paper sheet 53 while the bottom sheet 54 is formed from one layer of paper.

15 Figure 18 is a side view of a cooling pad where the top and bottom sheets are both formed from two layers being an outermost microperforated plastic laminate sheet 55A, 55B with a intermediate non-woven fabric sheet 56A, 56B.

20 Figure 19 illustrates a further cooling pad where the top sheet is formed from two layers being an outermost microperforated plastic laminate sheet 60 and an intermediate non-woven fabric sheet 61 while the bottom sheet is formed from one layer of non-woven fabric
25 62.

 Figures 20A and 20B illustrate a fluid absorbing pad 65 having a number of separate cells therein. The pad has a top sheet formed from two layer being an outermost microperforated plastic co-extruded
30 sheet 66 behind which is a non-woven fabric sheet 67. The bottom sheet is formed from two layers 68, 69 each being a non-woven fabric.

 The fluid absorbing pad comes in three main sizes being a twelve cell pad either 400mm X 141mm, or
35 200mm X 280mm, and a nine cell pad which is 200mm X 211mm. Other sizes are available.

 In Figure 20, the absorbing pad is a four layer pad. The plastic is of a different type being a multi-

layered co-extruded film. The three different layers are made of either a high density polyethylene or low density polyethylene/linear low density polyethylene blends to adjust melting temperatures. The top layer of the pad is
5 the co-extruded plastic with the second layers being a non-woven fabric. The bottom sheet is made of two non-woven fabric layers.

It should be appreciated that various other changes and modifications can be made to the invention.
10 That is, it should be appreciated that the pad size and shape can vary, the type of top and bottom sheet can vary as long as at least one sheet has the microperforations, the type of polymer and the amount of polymer can also vary to suit. The pad can be used as a biofluid
15 absorbing pad, as a cooling pad, as a heating pad (it being appreciated that the cooling pad, once swollen, can be heated to function as a "hot pack"). The pads can be used for humidity control in packaging and may find use in the fresh flower industry.

CLAIMS:

1. An absorbent pad which has a top sheet and a bottom sheet, the sheets being joined to form at least one cell, a absorbent located within the cell, characterised in that at least one of the sheets is formed from a liquid impermeable material containing microperforations to allow fluid to pass through the microperforations and into the cell.
2. The pad of claim 1, wherein the top sheet is formed from the microperforated material.
3. The pad of claim 1, wherein the microperforations are spread over the sheet in a substantially homogenous fashion.
4. The pad of claim 1, wherein the microperforation are between 10 to 200 microns.
5. The pad of claim 4, comprising between 10 to 500 microperforations per square inch.
6. The pad of claim 1, having a width of between 200-500mm, between 2-10 cells extending across the pad, each cell being between 40mm to 100mm across.
7. The pad of claim 1, wherein the microperforated sheet is formed from plastic.
8. The pad of claim 1, comprising a fluid absorbing pad having a top sheet and a bottom sheet both being microperforated.
9. The pad of claim 1, comprising a fluid absorbing pad having a top microperforated sheet and a bottom non-woven fabric sheet.
10. The pad of claim 1, comprising a fluid absorbing pad having a top microperforated sheet and a bottom paper sheet.
11. The pad of claim 1, comprising a cooling pad having a top sheet and a bottom sheet both being microperforated.
12. The pad of claim 1, comprising a cooling pad having a top sheet which is microperforated and a water impervious bottom sheet.
13. The pad of claim 1, comprising a cooling pad

having a top sheet which is microperforated and a bottom sheet formed from a non-woven fabric.

14. The pad of claim 1, comprising a fluid absorbing pad having top and bottom sheets, the top sheet
5 being formed from three layers comprising an outermost microperforated layer, an intermediate permeable paper layer, and an inner microperforated layer.

15. The pad of claim 14, wherein the bottom sheet is formed from the same three layers as the top sheet.

10 16. The pad of claim 14, wherein the bottom sheet is a non-woven fabric.

17. The pad of claim 14, wherein the bottom sheet is paper.

15 18. The pad of claim 14,15,16 or 17 comprising a cooling pad.

19. The pad of claim 14, comprising a cooling pad and where the bottom sheet is water impervious.

20. The pad of claim 1, wherein the top sheet is formed from two layers being an outermost microperforated
20 layer and an inner paper layer.

21. The pad of claim 20, wherein the bottom sheet is formed from one layer.

22. The pad of claim 20, comprising a cooling pad wherein the bottom sheet is the same as the top sheet.

25 23. The pad of claim 20, wherein the bottom sheet is a non woven fabric.

24. The pad of claim 20, wherein the bottom sheet is a paper.

30 25. The pad of claim 1, comprising a cooling pad where the top sheet is formed from two layers being an outer microperforated layer and an inner non woven fabric layer.

26. The pad of claim 25, wherein the bottom sheet is the same as the top sheet.

35 27. The pad of claim 25, wherein the bottom sheet is a non woven fabric.

28. The pad of claim 1, wherein the top sheet is formed from two layers being a microperforated plastic

co-extruded layer and a non woven fabric layer, and the bottom sheet is formed from two layers of non woven fabric.

FIGURE 1a

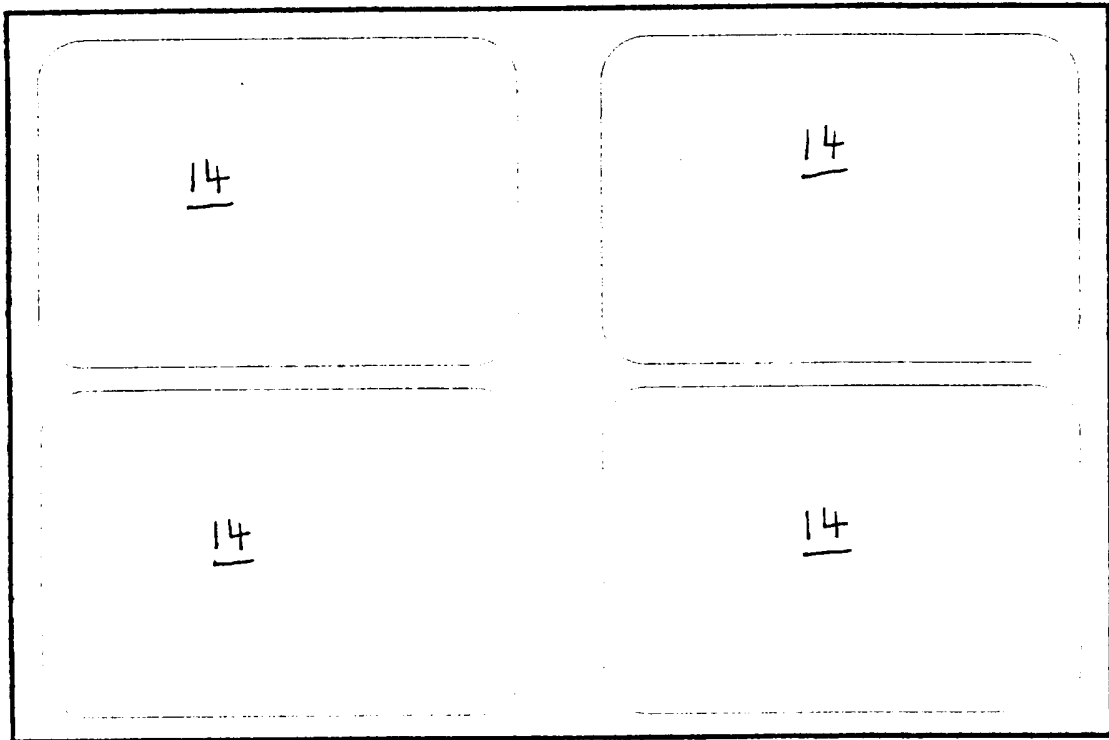

FIGURE 1b

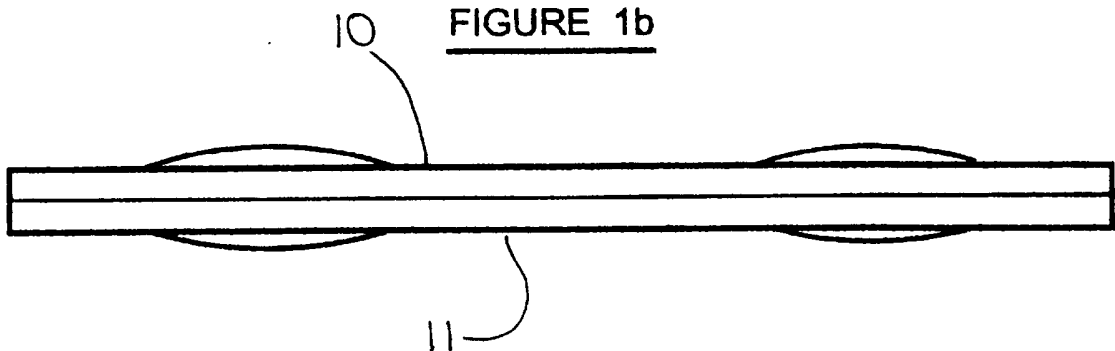

FIGURE 2a

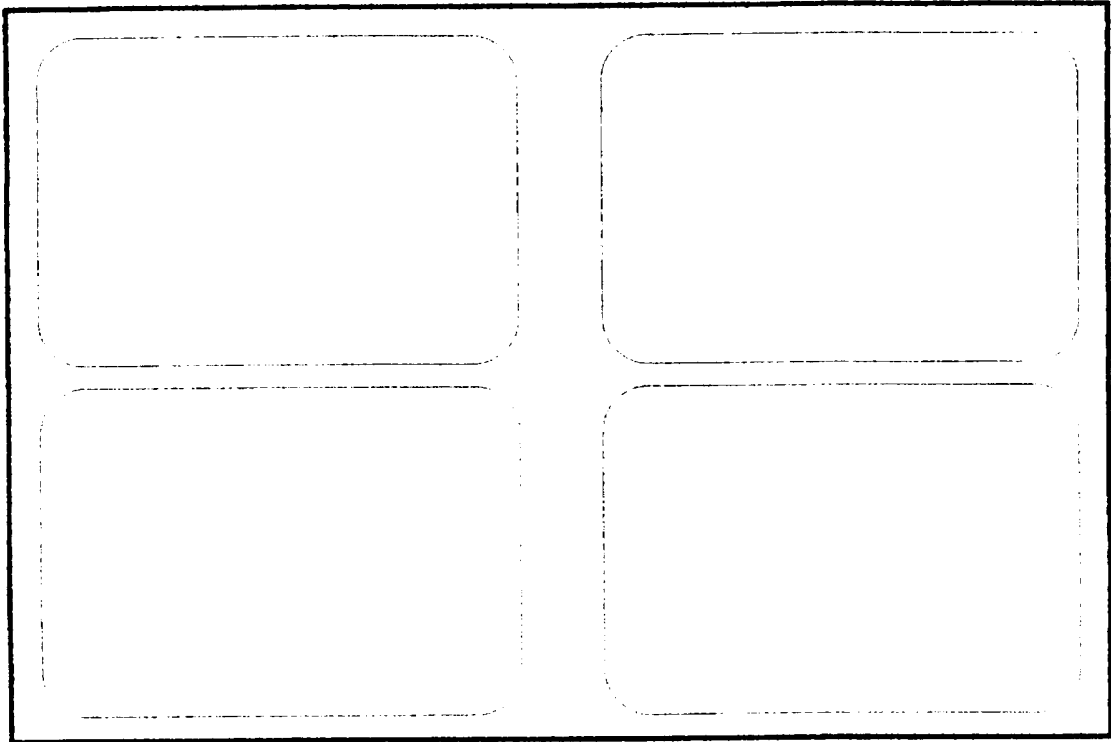

FIGURE 2b

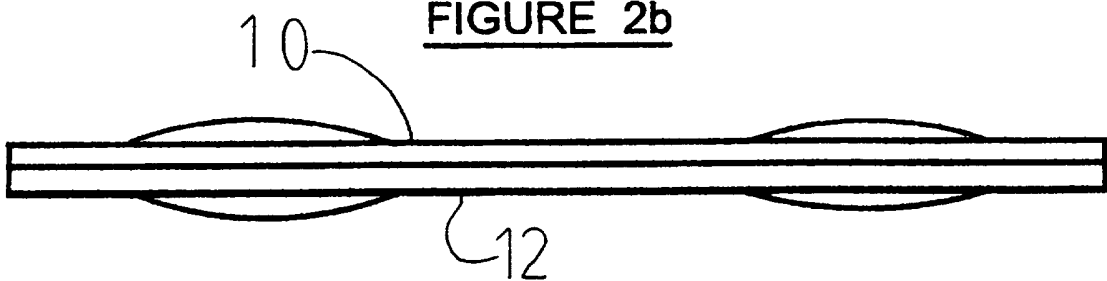

FIGURE3a

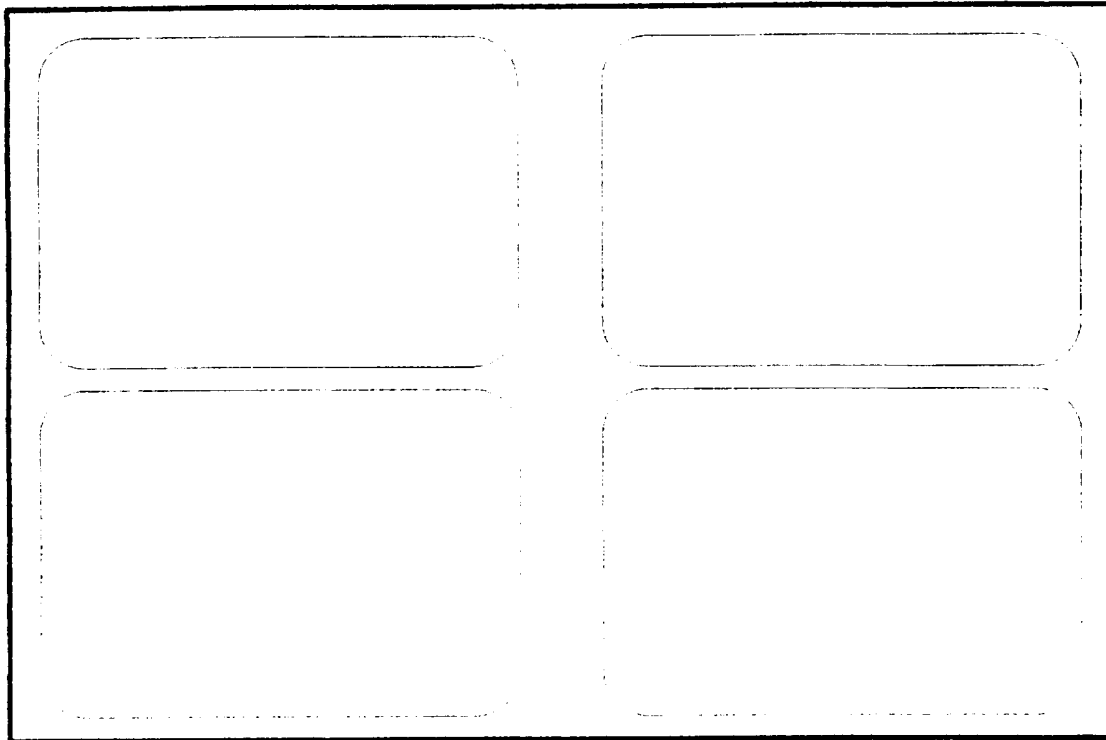

FIGURE3b

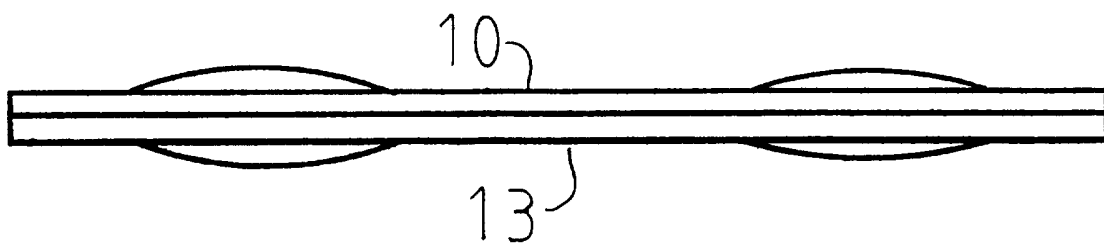

FIGURE 4a

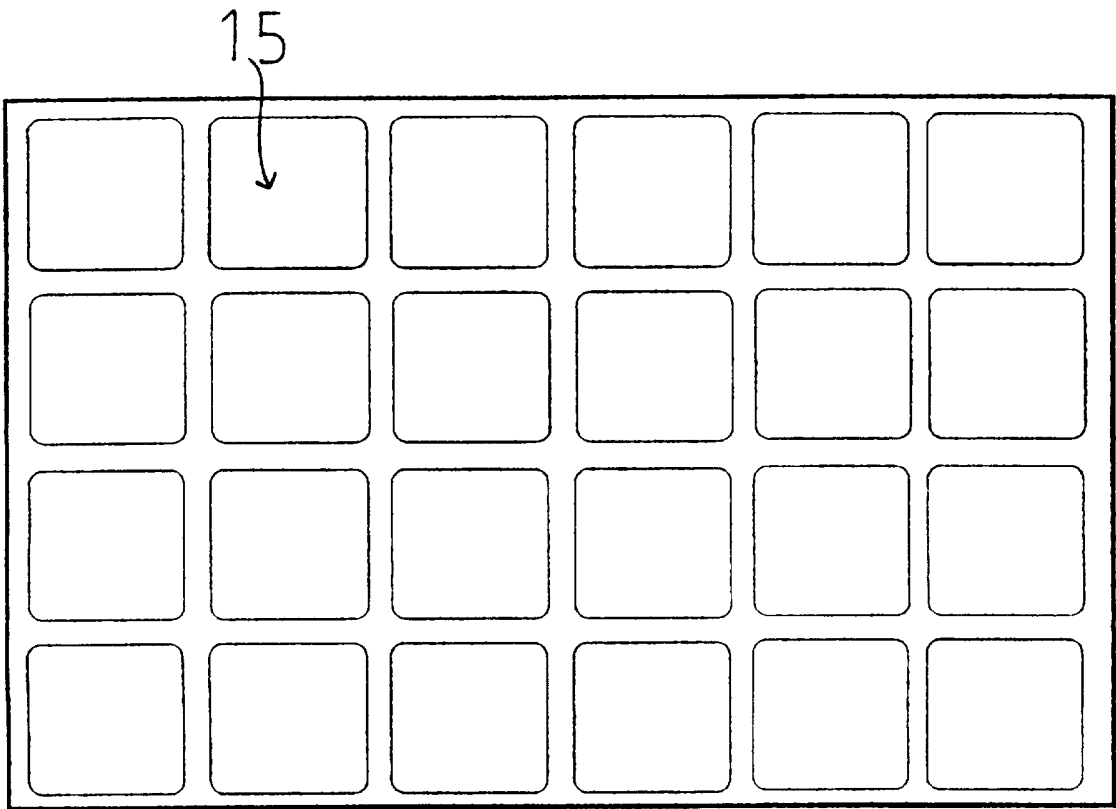
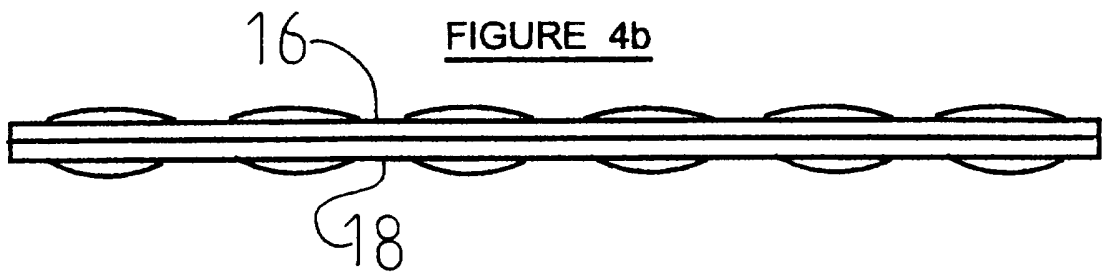

FIGURE 4b



5/20

FIGURE 5a

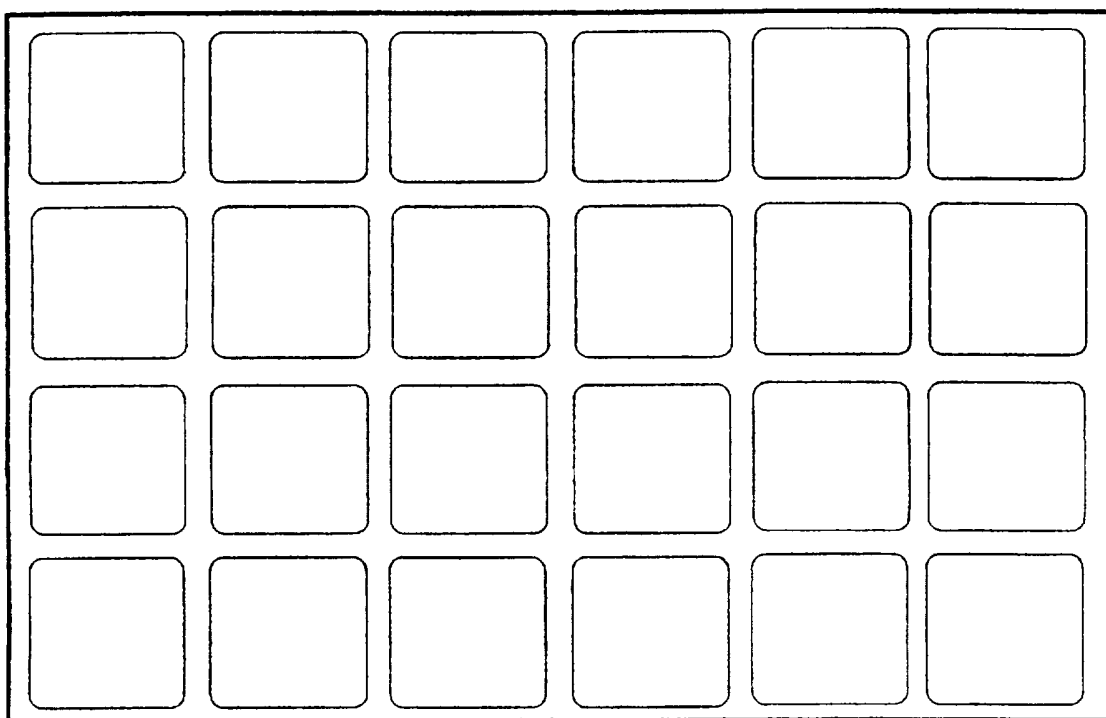

FIGURE 5b

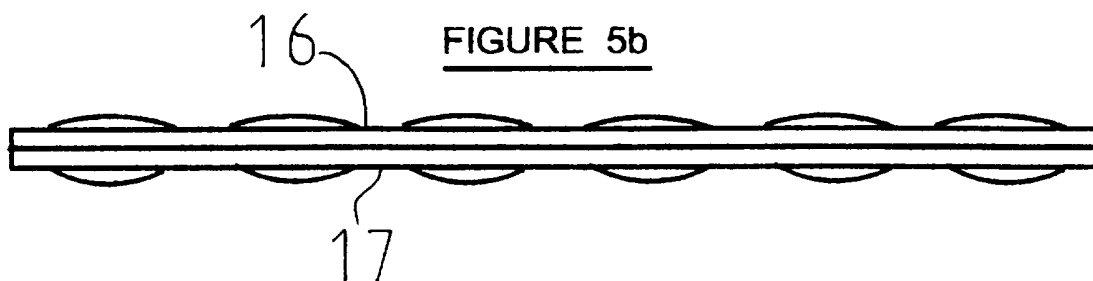

FIGURE 6a

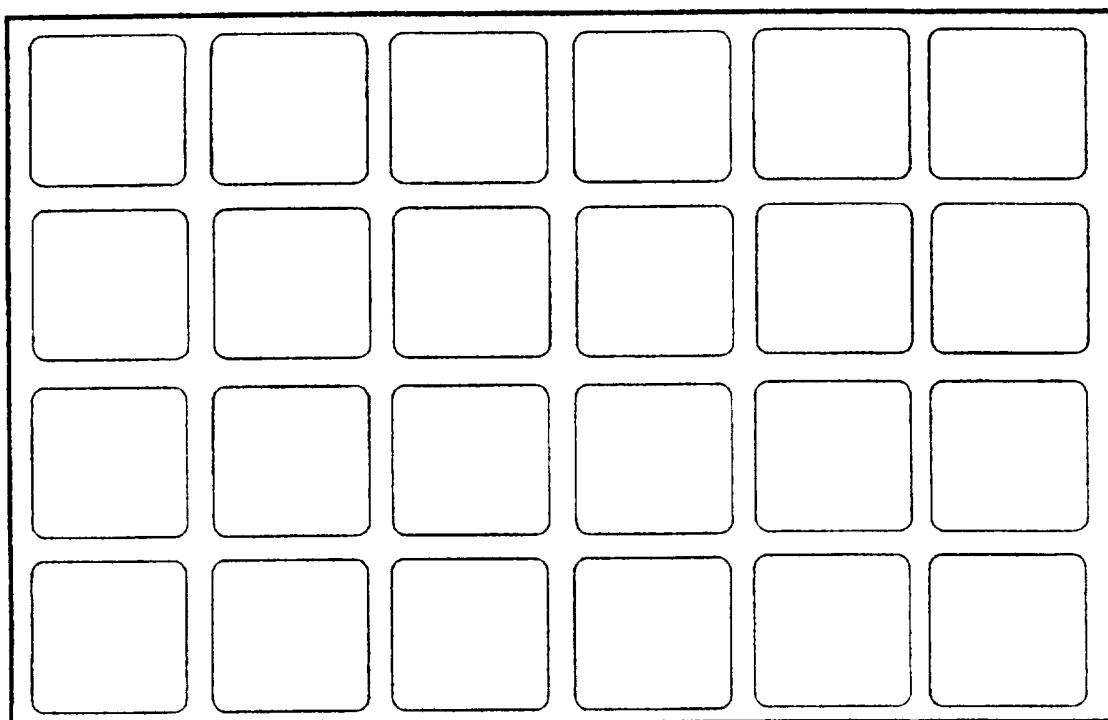

FIGURE 6b

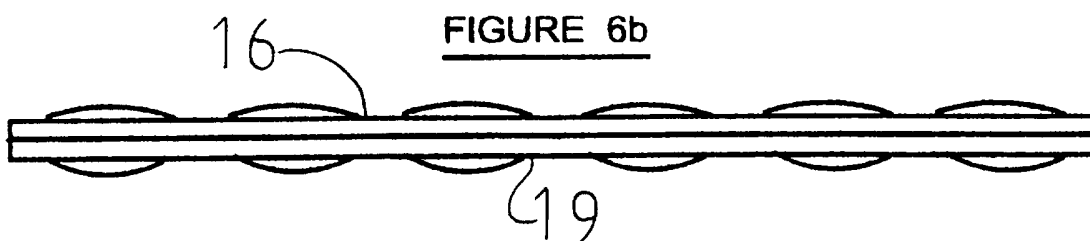

FIGURE 7a

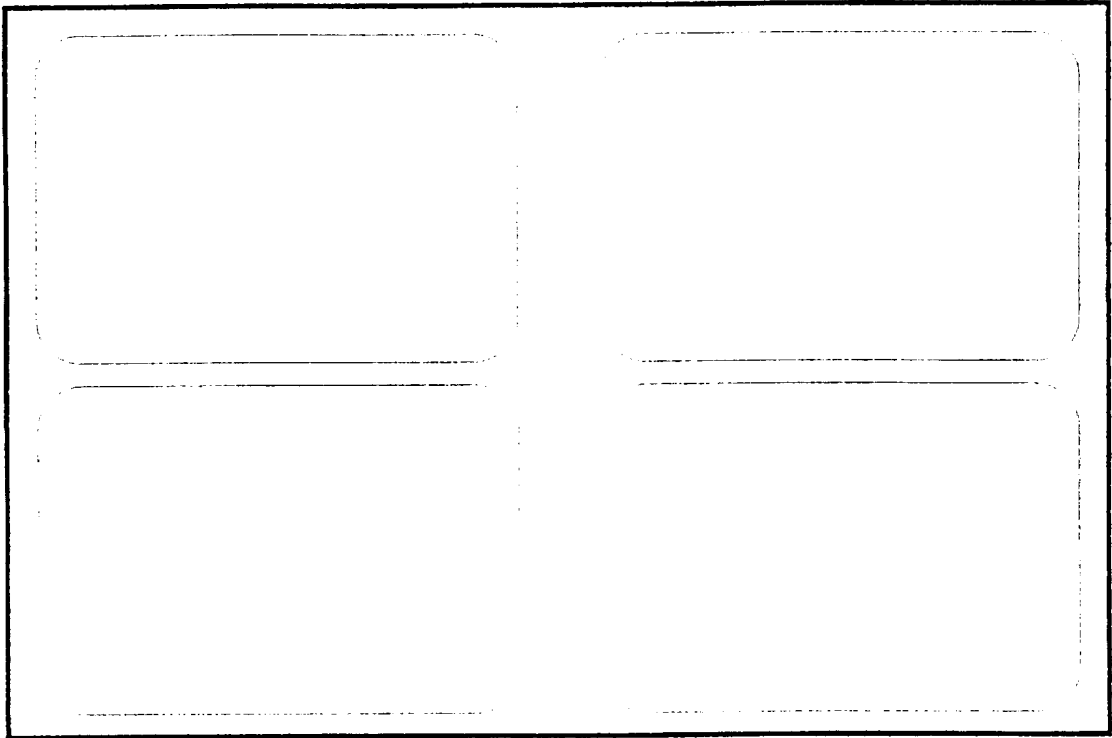

FIGURE 7a

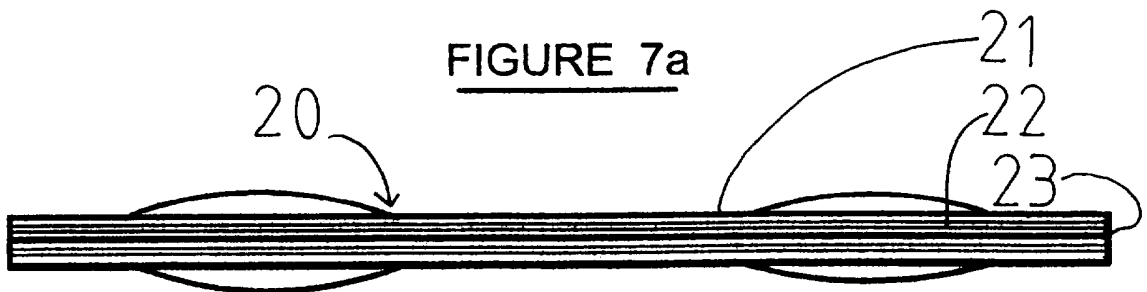

FIGURE 8a

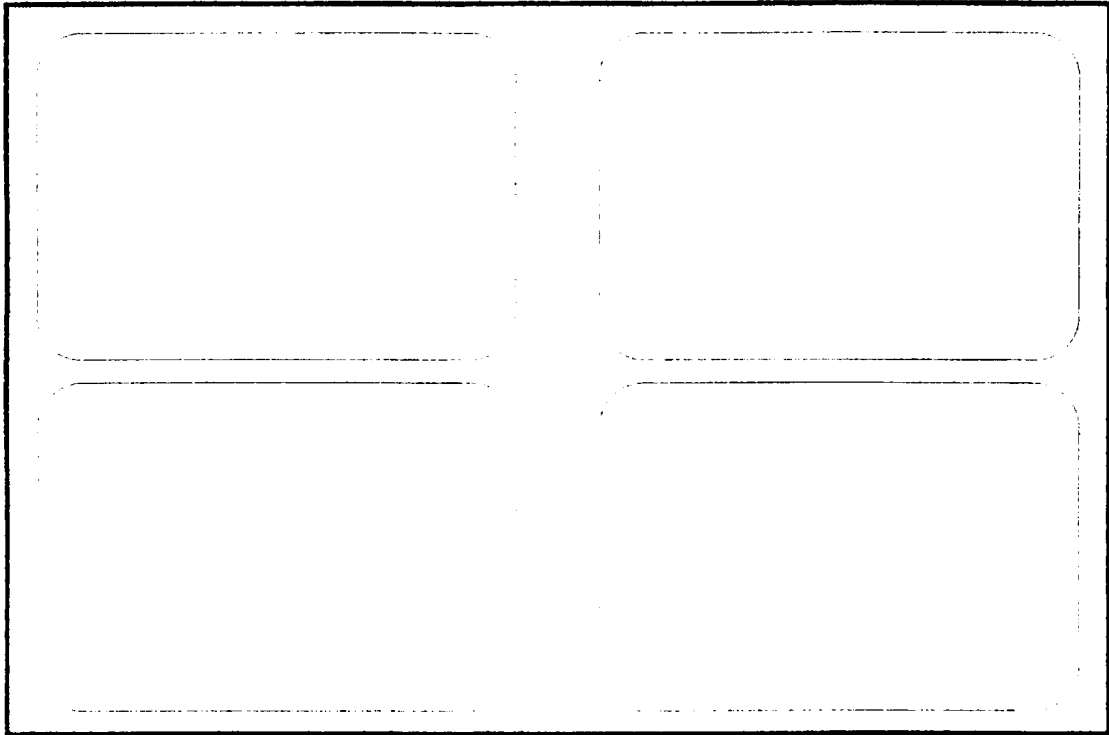

FIGURE 8b

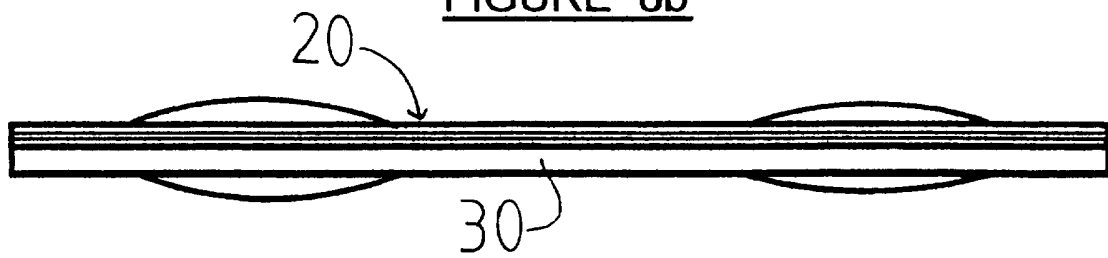

FIGURE 9a

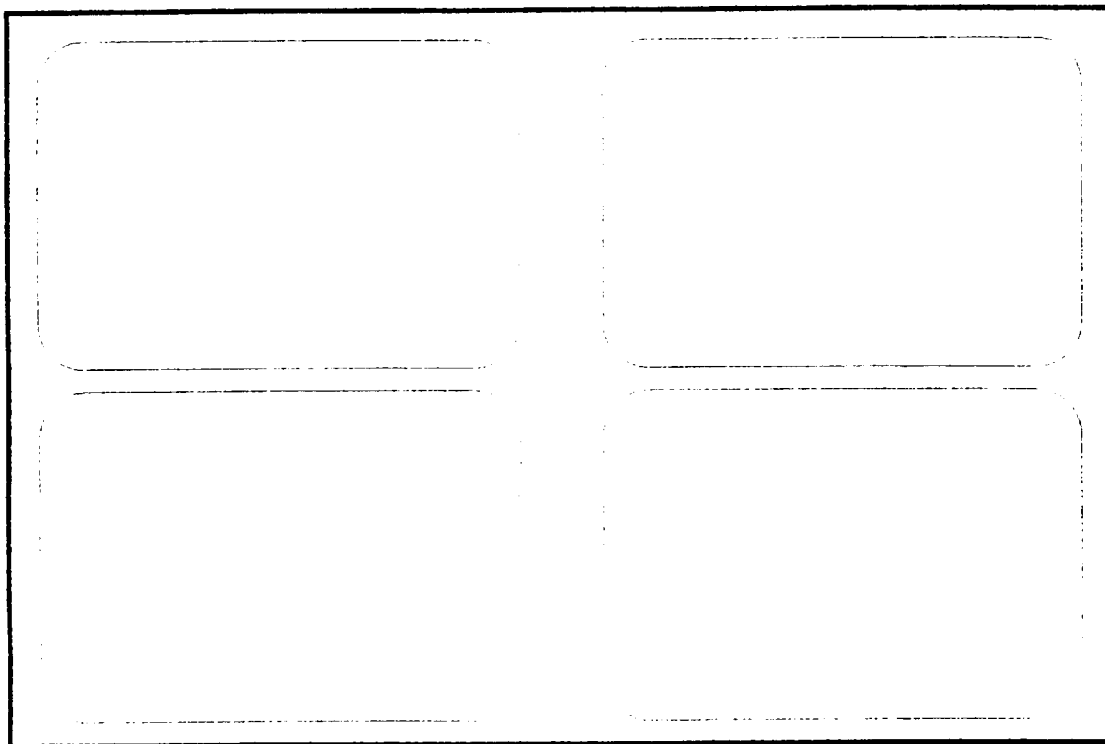

FIGURE 9b

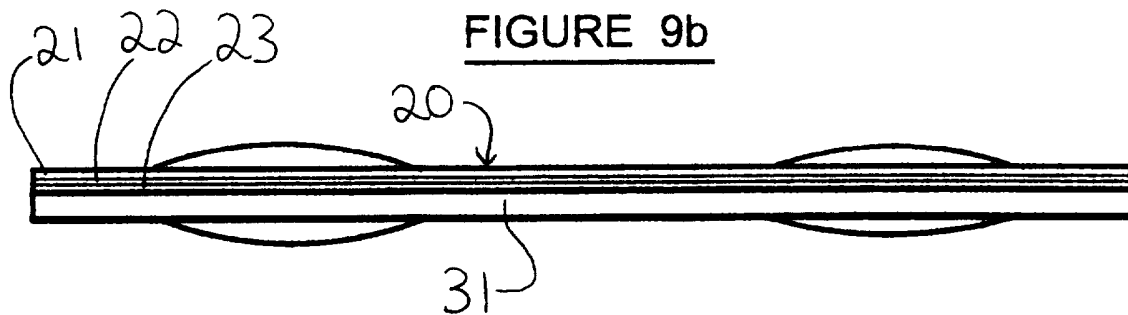

FIGURE 10a

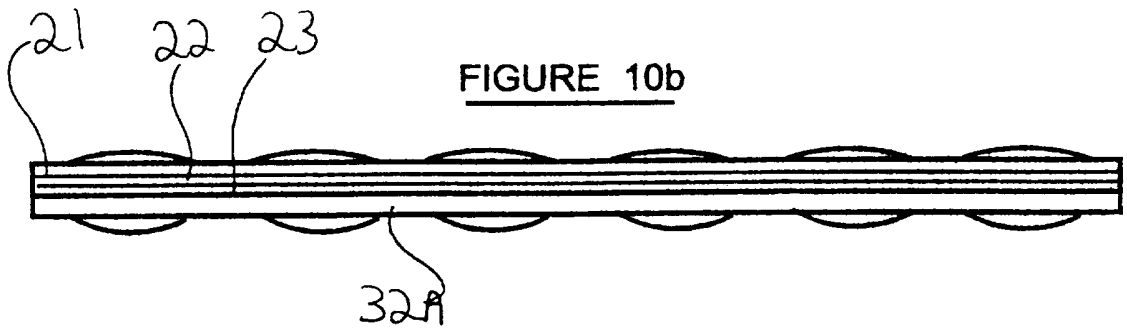
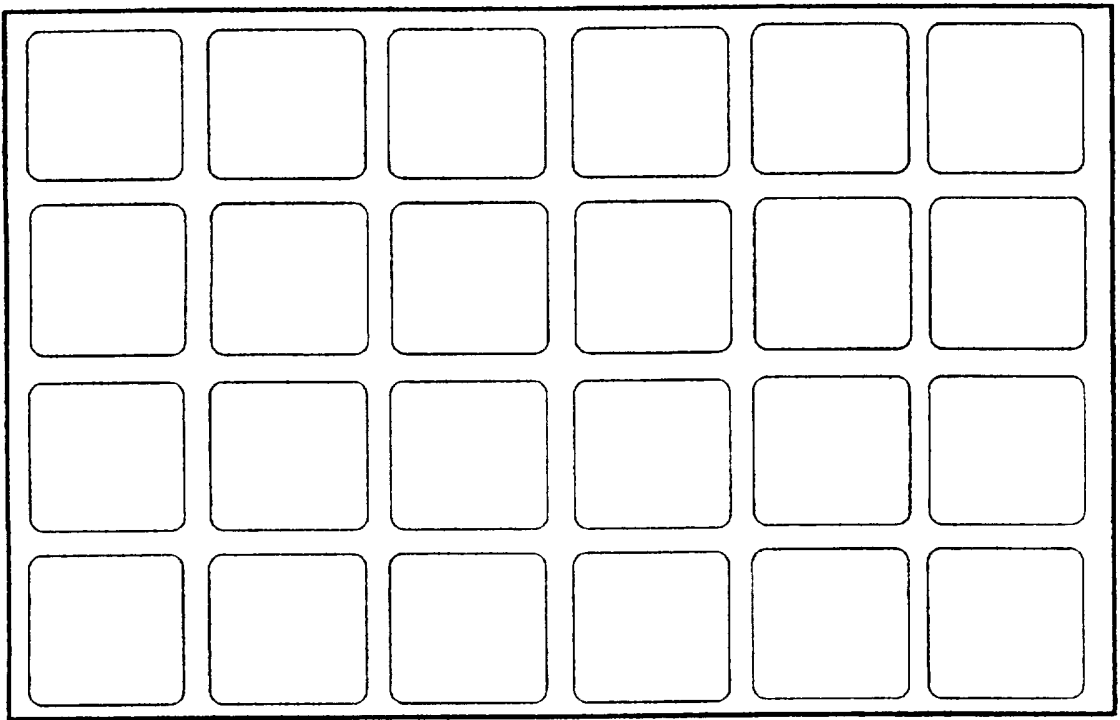

FIGURE 10b

11/20

FIGURE 11a

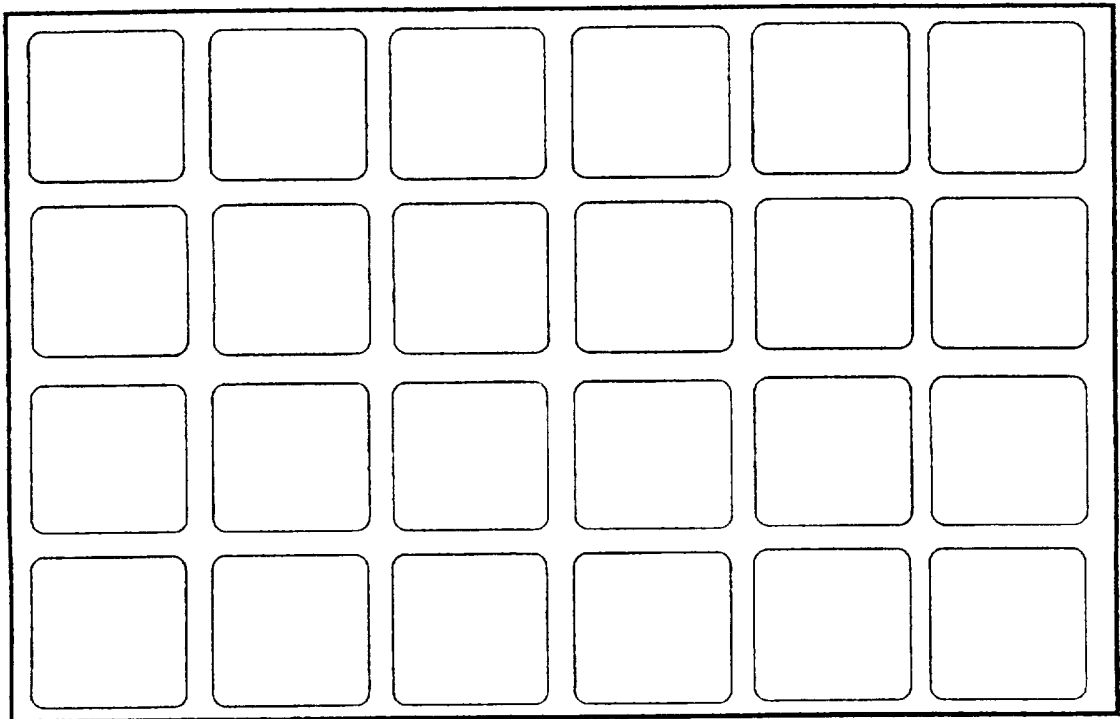
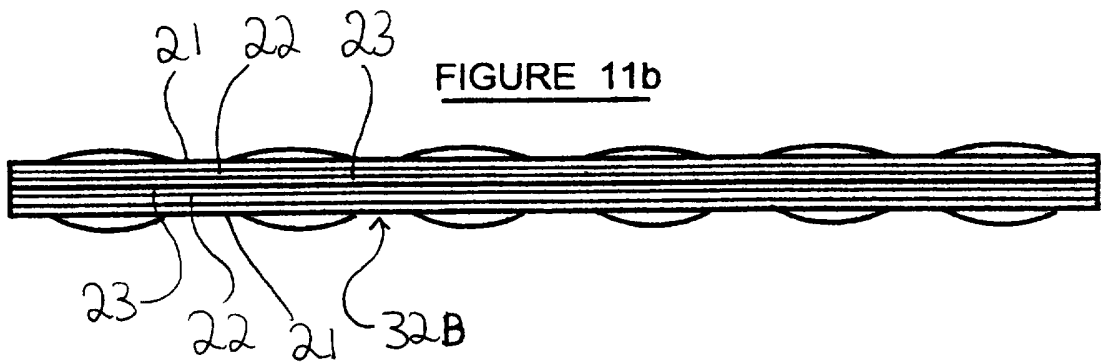

FIGURE 11b



12/20

FIGURE 12a

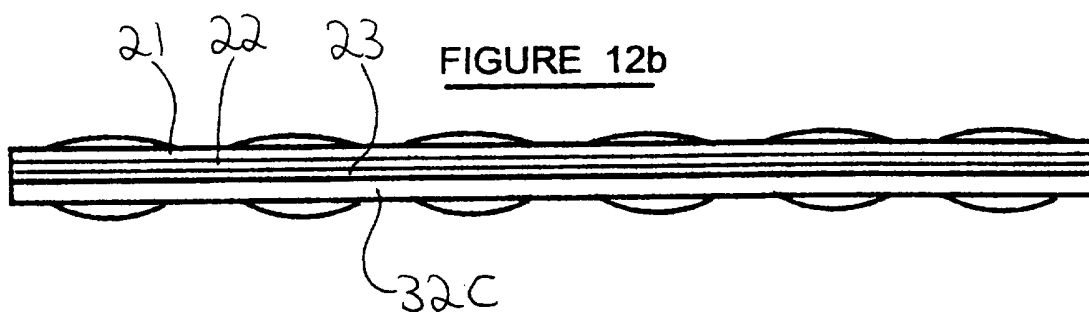
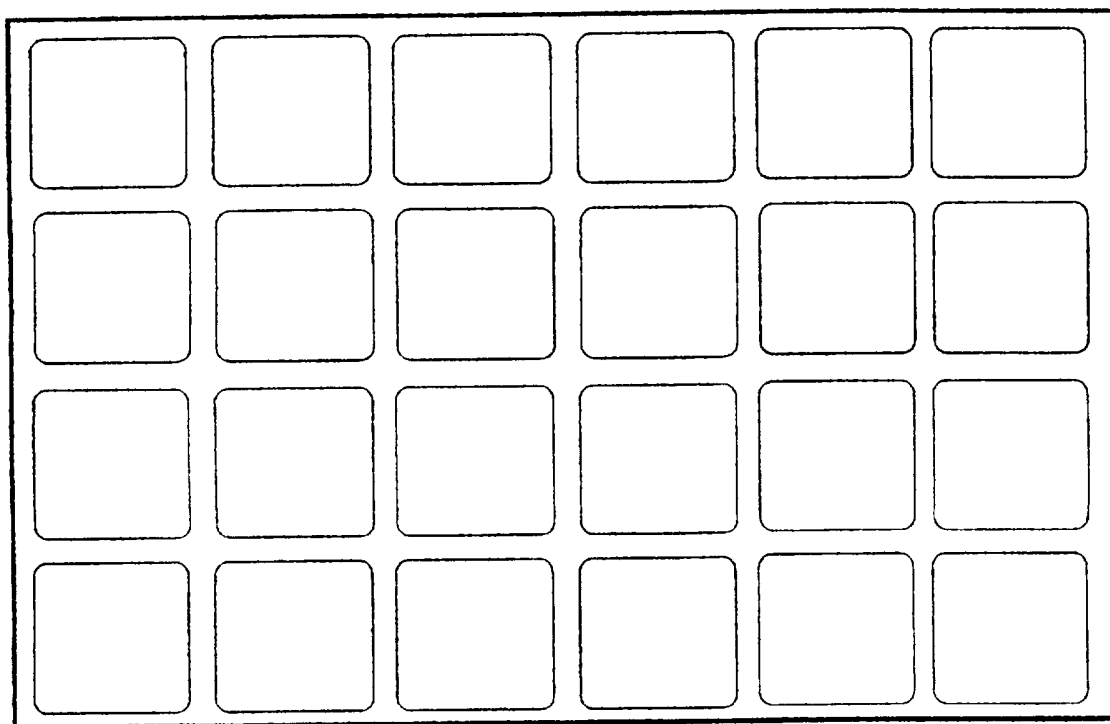

FIGURE 12b

FIGURE 13a

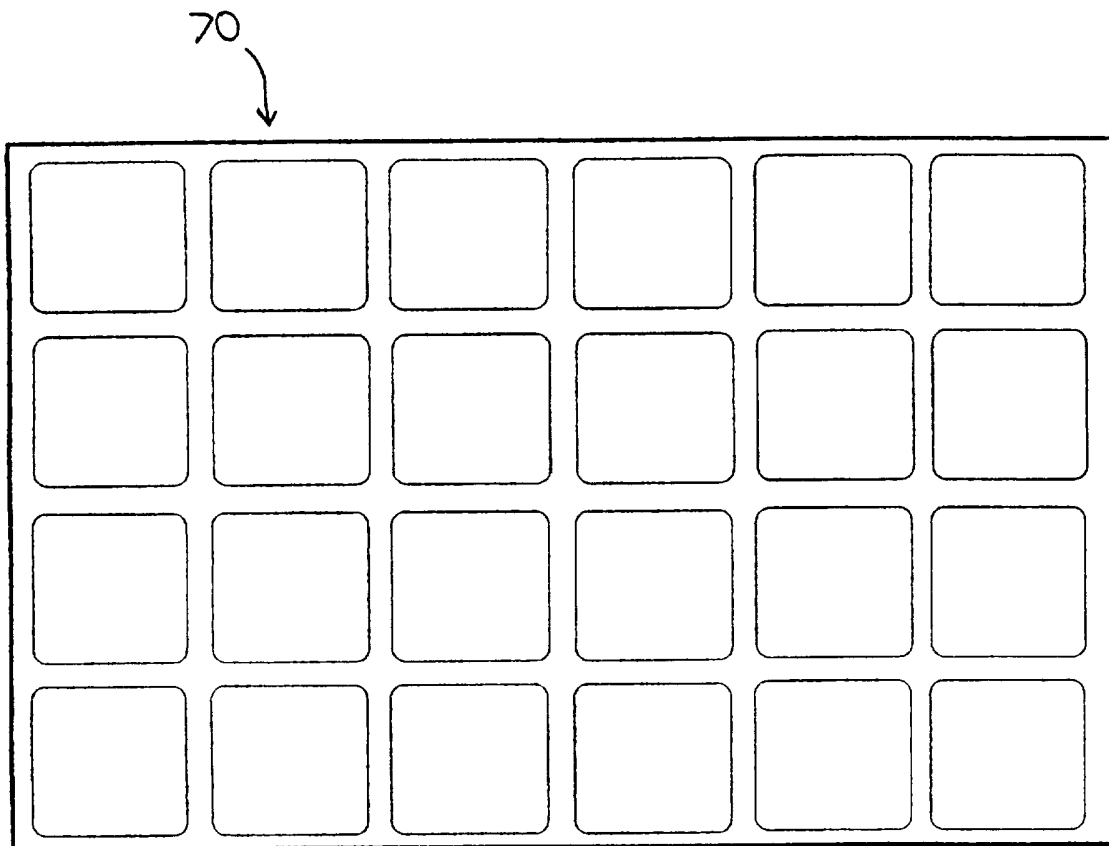

FIGURE 13b

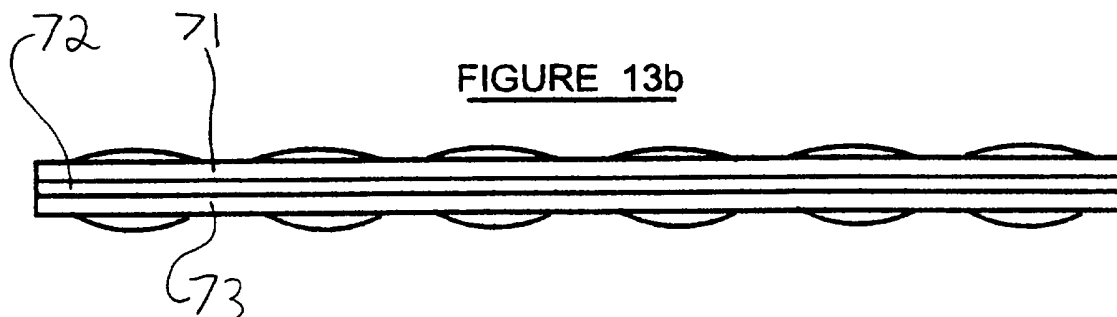

FIGURE 14a

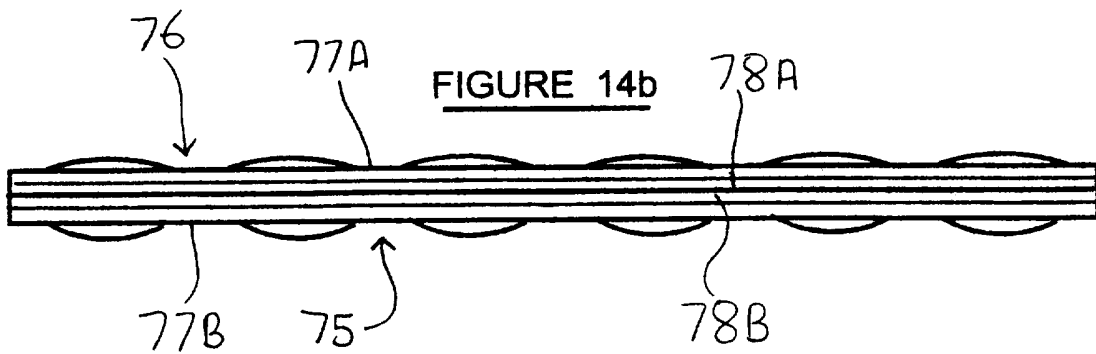
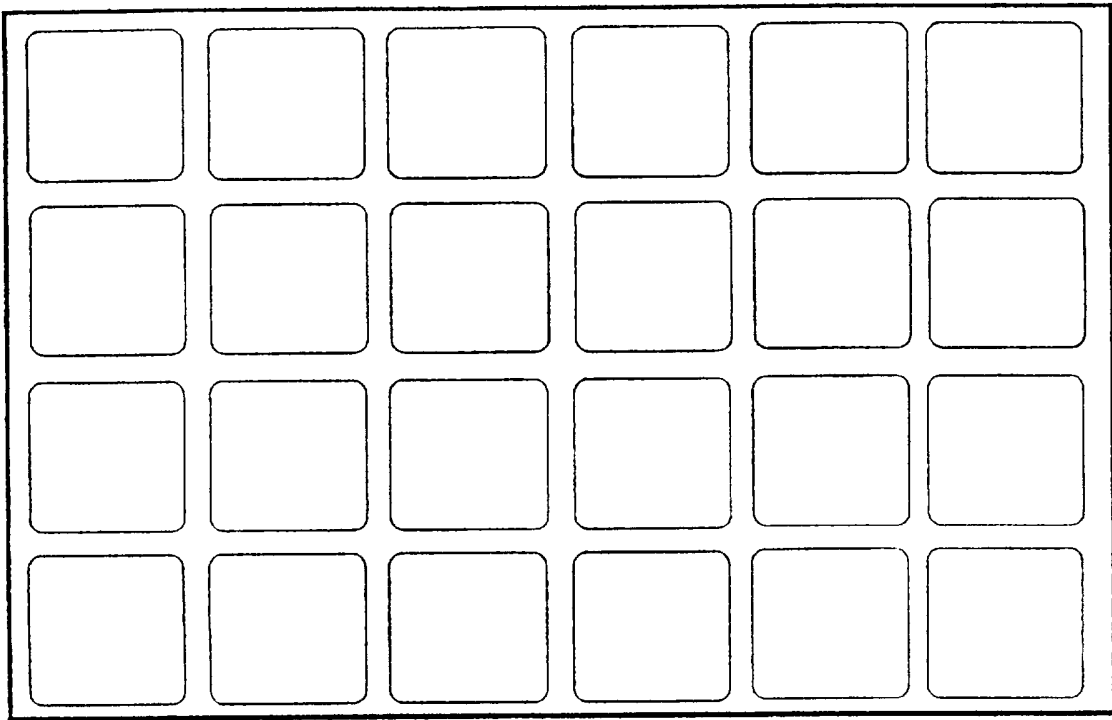

FIGURE 14b

FIGURE 15a

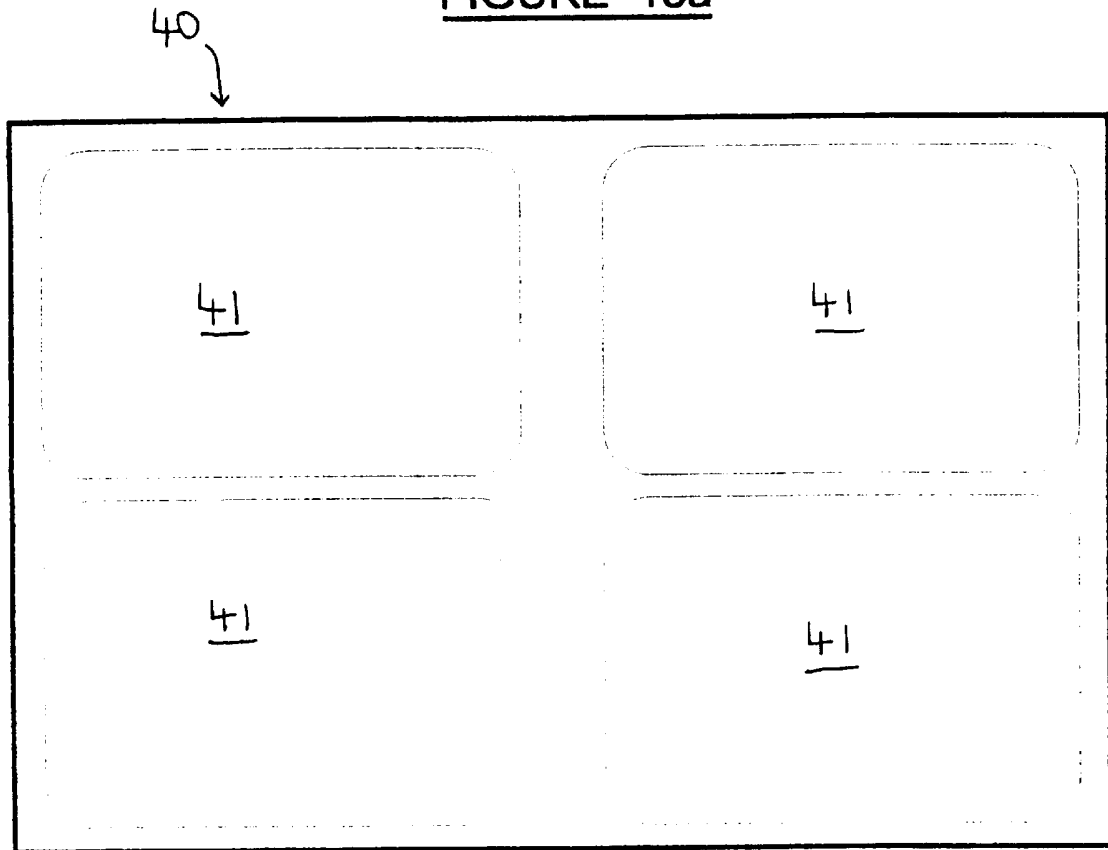

FIGURE 15b

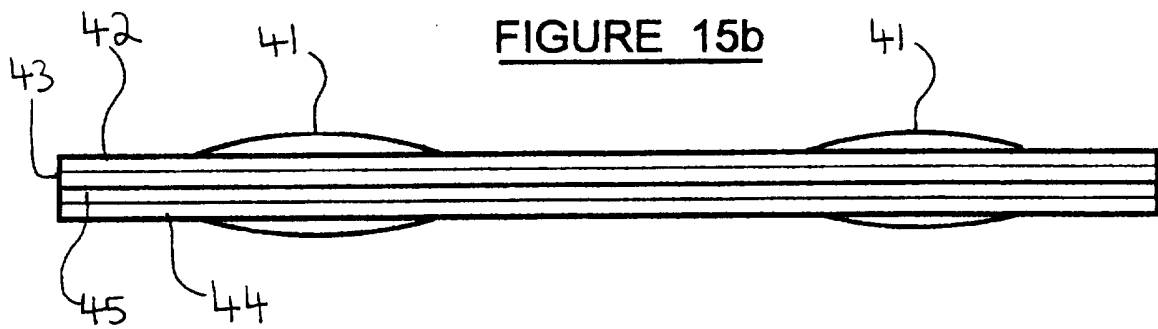

FIGURE 16a

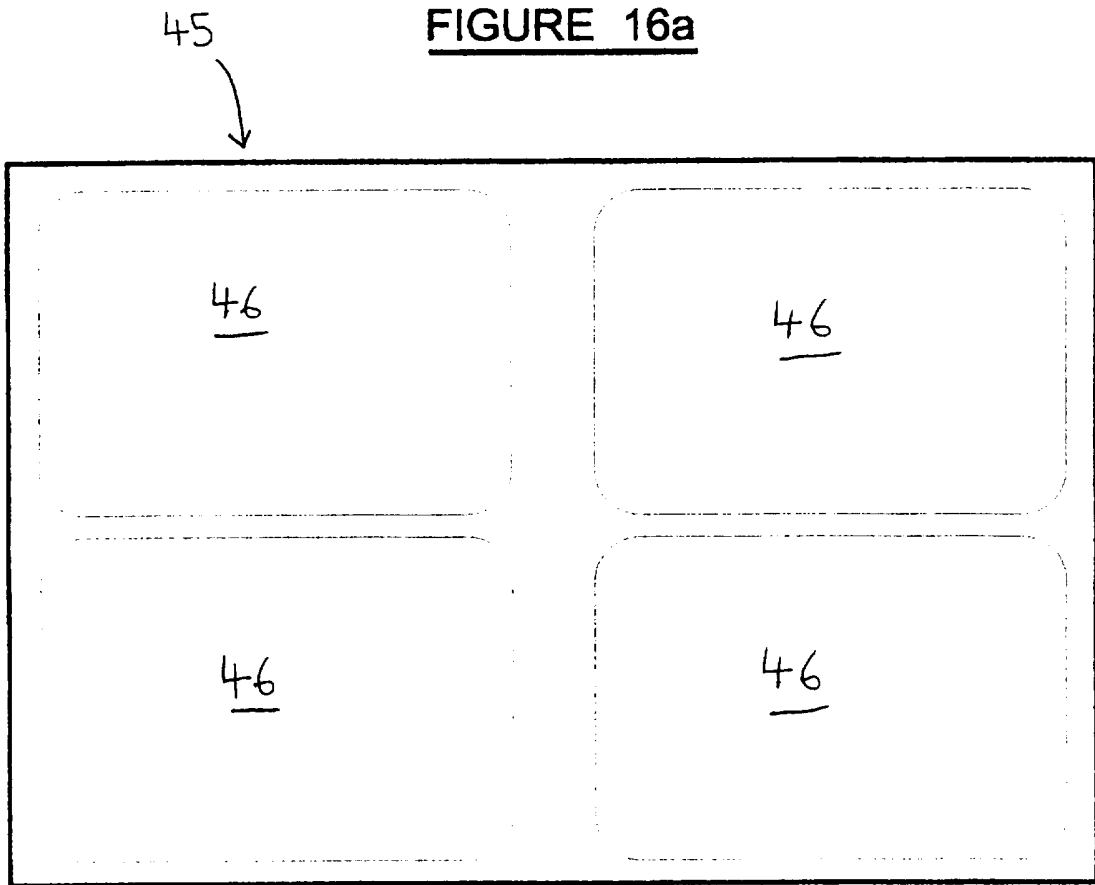

FIGURE 16b

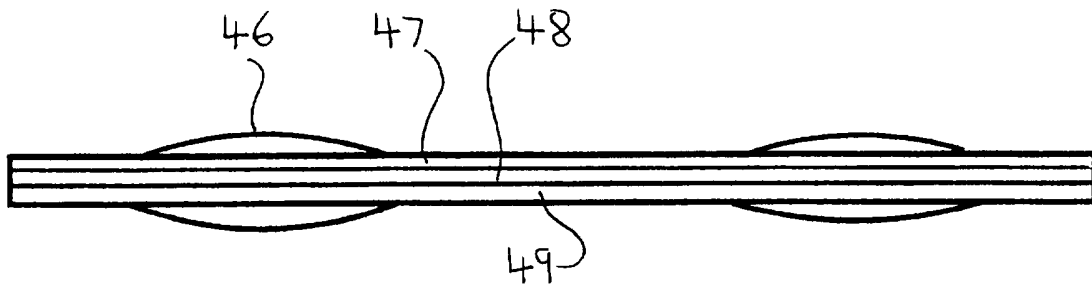

FIGURE 17a

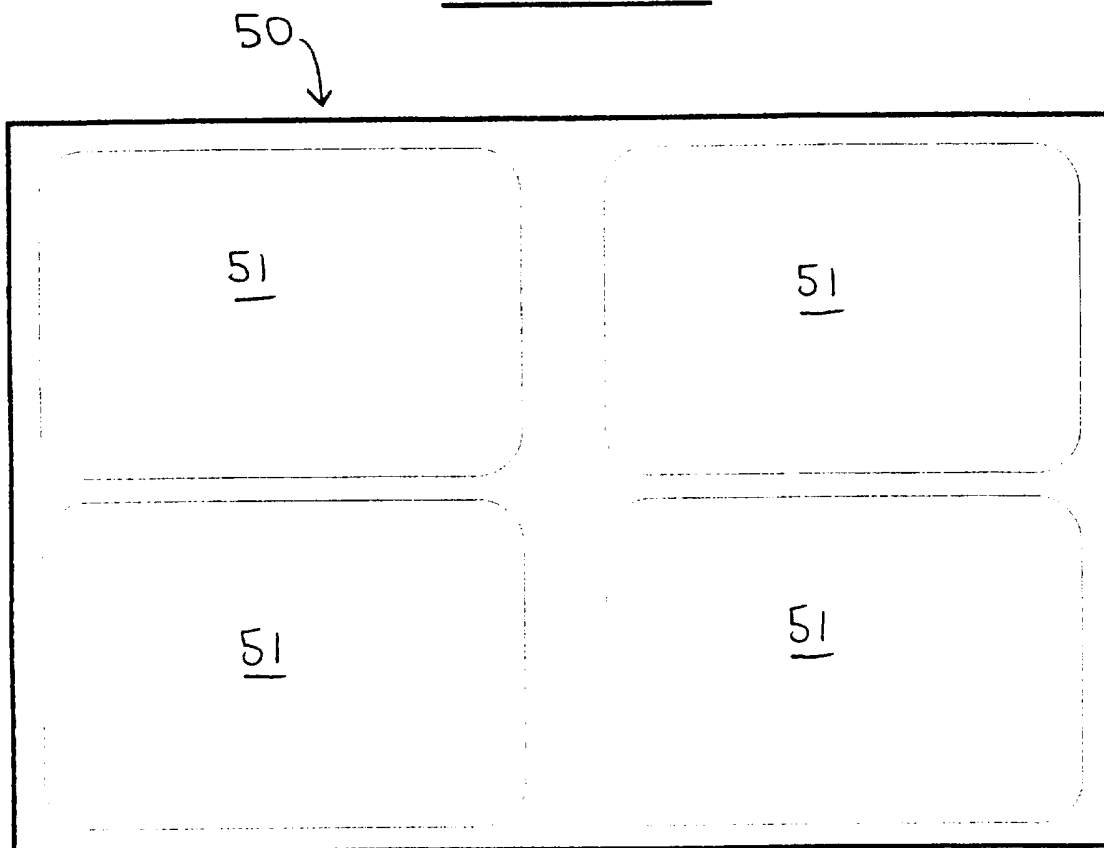
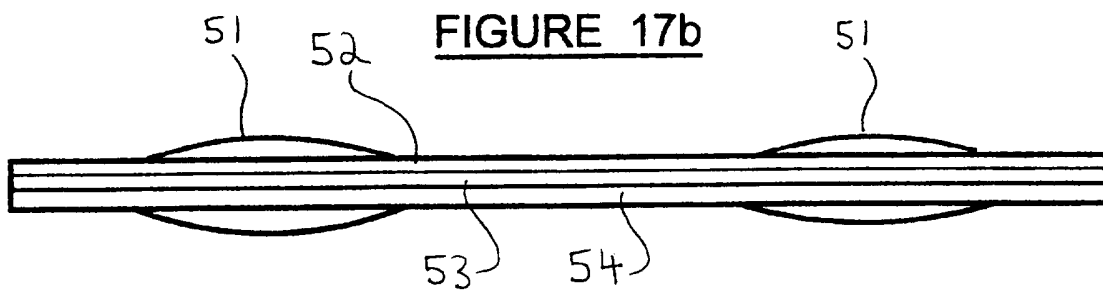
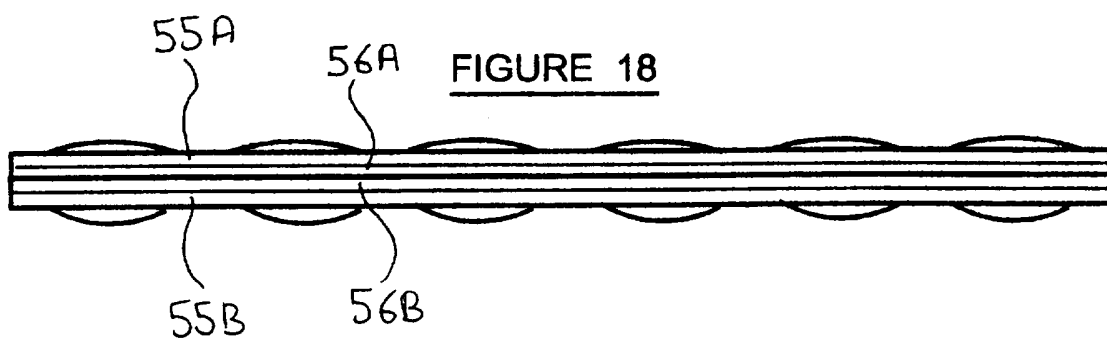
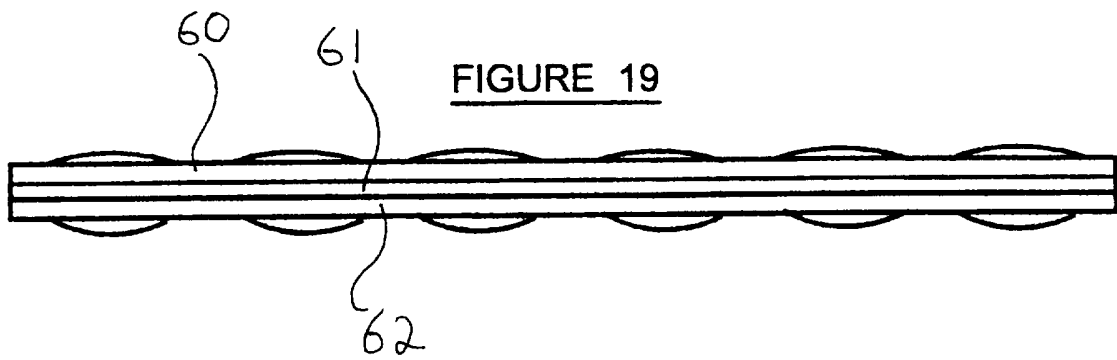

FIGURE 17b







20/20

FIGURE 20a

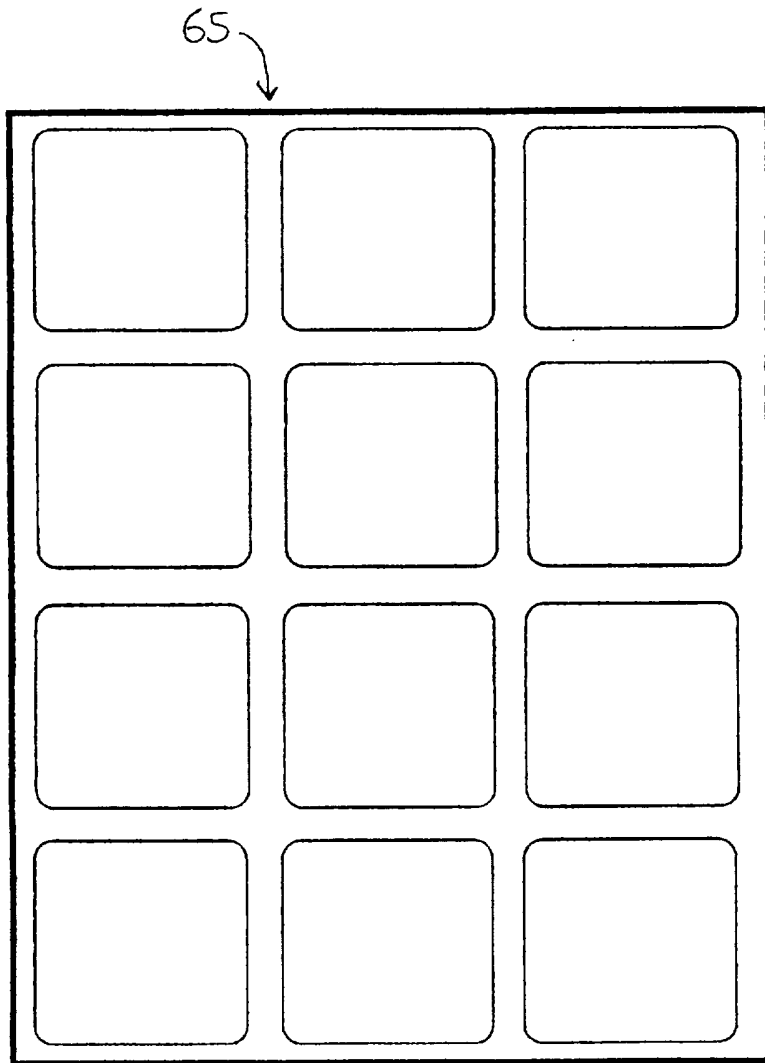
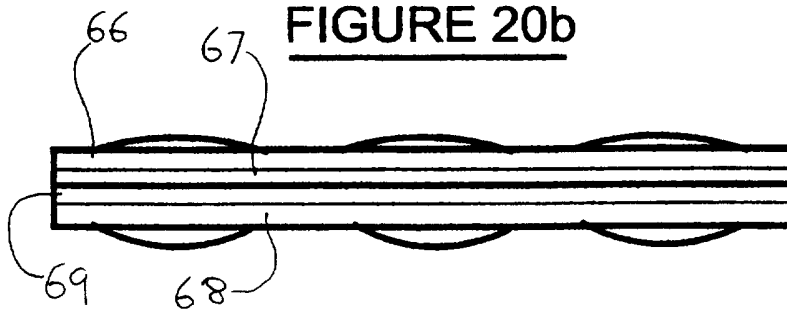

FIGURE 20b



INTERNATIONAL SEARCH REPORT

International Application No.
PCT/AU 97/00086

A. CLASSIFICATION OF SUBJECT MATTER		
Int Cl ⁶ : B65D 81/18, 81/26		
According to International Patent Classification (IPC) or to both national classification and IPC		
B. FIELDS SEARCHED		
Minimum documentation searched (classification system followed by classification symbols) IPC: B65D 81/18, 81/26		
Documentation searched other than minimum documentation to the extent that such documents are included in the fields searched AU: IPC as above		
Electronic data base consulted during the international search (name of data base and, where practicable, search terms used) Derwent		
C. DOCUMENTS CONSIDERED TO BE RELEVANT		
Category*	Citation of document, with indication, where appropriate, of the relevant passages	Relevant to claim No.
X	AU 11573/95 A (SHOWA DENKO KK) 17 August 1995 pages 5-11, figure 2	1-11, 13, 20-28
X Y	AU 42151/93 A (ACI OPERATIONS PTY LTD) 27 January 1994 figures 2, 2a figures 2, 2a	1-9, 11-13, 25-26 20, 22
Y	EP 353334 A (KIMBERLY-CLARK CORPORATION) 7 February 1990 figure 2 and abstract	20, 22
<input checked="" type="checkbox"/> Further documents are listed in the continuation of Box C <input checked="" type="checkbox"/> See patent family annex		
* Special categories of cited documents: "A" document defining the general state of the art which is not considered to be of particular relevance "E" earlier document but published on or after the international filing date "L" document which may throw doubts on priority claim(s) or which is cited to establish the publication date of another citation or other special reason (as specified) "O" document referring to an oral disclosure, use, exhibition or other means "P" document published prior to the international filing date but later than the priority date claimed "T" later document published after the international filing date or priority date and not in conflict with the application but cited to understand the principle or theory underlying the invention "X" document of particular relevance; the claimed invention cannot be considered novel or cannot be considered to involve an inventive step when the document is taken alone "Y" document of particular relevance; the claimed invention cannot be considered to involve an inventive step when the document is combined with one or more other such documents, such combination being obvious to a person skilled in the art "&" document member of the same patent family		
Date of the actual completion of the international search 27 March 1997		Date of mailing of the international search report 09.04.97
Name and mailing address of the ISA/AU AUSTRALIAN INDUSTRIAL PROPERTY ORGANISATION PO BOX 200 WODEN ACT 2606 AUSTRALIA Facsimile No.: (06) 285 3929		Authorized officer JAGDISH BOKIL Telephone No.: (06) 283 2371

INTERNATIONAL SEARCH REPORT

International Application No.

PCT/AU 97/00086

C (Continuation) DOCUMENTS CONSIDERED TO BE RELEVANT		
Category*	Citation of document, with indication, where appropriate, of the relevant passages	Relevant to claim No.
X	WO 90/03320 A (CLEAN-PAK) 5 April 1990 abstract	1-8
X	US 4275811 A (MILLER) 30 June 1981 figure 1	1-7, 20-21

INTERNATIONAL SEARCH REPORT
Information on patent family members

International Application No.
PCT/AU 97/00086

This Annex lists the known "A" publication level patent family members relating to the patent documents cited in the above-mentioned international search report. The Australian Patent Office is in no way liable for these particulars which are merely given for the purpose of information.

Patent Document Cited in Search Report		Patent Family Member					
US	4275811	CA	1143928	CA	1158033	US	4382507
		US	4410578	US	4321997	CA	1150681
WO	9003320	US	5055332	AU	43155/89	AU	637770
		CA	1329573	EP	434733	NZ	230697
		US	4940621	US	5022945		

END OF ANNEX