

G. C. WERNER.
 CUSHIONING MEMBER FOR PUMPS.
 APPLICATION FILED MAY 11, 1908.

929,263.

Patented July 27, 1909.

Fig. 1.

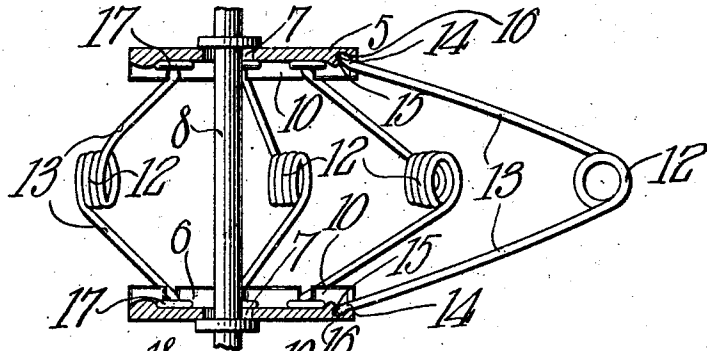

Fig. 2.

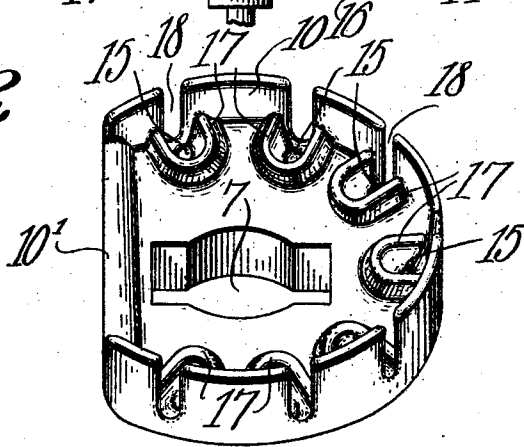

Fig. 4.

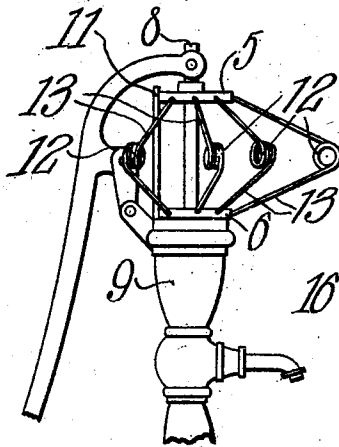
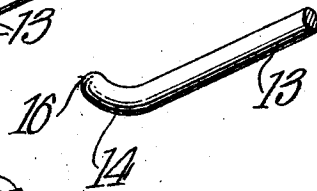

Fig. 3.



Witnesses
E. J. Hunt
L. M. Decker

Inventor
George C. Werner.

By *C. A. Snow & Co.*
 Attorneys

UNITED STATES PATENT OFFICE.

GEORGE C. WERNER, OF BEATRICE, NEBRASKA.

CUSHIONING MEMBER FOR PUMPS.

No. 929,263.

Specification of Letters Patent.

Patented July 27, 1909.

Application filed May 11, 1908. Serial No. 432,151.

To all whom it may concern:

Be it known that I, GEORGE C. WERNER, a citizen of the United States, residing at Beatrice, in the county of Gage and State of Nebraska, have invented a new and useful Cushioning Member for Pumps, of which the following is a specification.

This invention relates to cushioning means for pumps and has for its object to provide a cushioning member or spring for equalizing the operation of the pump and preventing damage from unnecessary jar when the device is employed in connection with a windmill or similar operating means.

A further object of the invention is to provide a cushioning member including spaced heads having alined openings formed therein for the reception of the pump rod, said heads being provided with a marginal row of sockets adapted to receive the adjacent ends of the springs so that when the pump is in operation a rocking movement will be imparted to the terminals of the springs and thus materially reduce friction between the parts.

A further object is to provide the heads with radiating slots or recesses which communicate with the sockets and serve to lock the springs against accidental displacement.

A still further object of the invention is generally to improve this class of devices so as to increase their utility, durability and efficiency.

Further objects and advantages will appear in the following description, it being understood that various changes in form, proportions and minor details of construction may be resorted to within the scope of the appended claim.

In the accompanying drawings forming a part of this specification: Figure 1 is a vertical sectional view of a pump attachment constructed in accordance with my invention, the cushioning members being shown in the positions assumed by them upon the completion of the down stroke of the pump. Fig. 2 is a perspective view of one of the heads detached. Fig. 3 is a similar view of a portion of one of the spring arms. Fig. 4 is a side elevation showing the attachment in position on a pump.

Similar numerals of reference indicate corresponding parts in all of the figures of the drawings.

The improved attachment forming the subject matter of the present invention in-

cludes spaced disks or heads 5 and 6 having alined openings 7 formed therein for the reception of a pump rod 8, the lower disk 6 being rigidly secured to the pump 9 and the upper disk or head disposed in spaced relation thereto, as shown.

The heads 5 and 6 are each provided with a marginal flange 10 and a flat portion 10' adapted to bear against a vertical bar or standard 11 carried by the pump and thus assist in guiding the movable head 5 when the pump is in operation.

Interposed between the heads or disks 5 are a plurality of cushioning members or springs preferably seven in number, as shown, and each formed of a single piece of wire having an intermediate portion bent to form a coil 12, the wire being thence extended laterally to form diverging arms 13, the ends of which are bent to produce angularly disposed bearing fingers 14 adapted to engage sockets 15 formed in the adjacent disks or heads.

The sockets 15 are disposed concentric with the flange 10 and are each provided with a curved wall or bearing surface for engagement with the correspondingly curved or rounded terminal 16 of the bearing fingers 14 whereby when the pump is in operation a rocking movement will be imparted to the said bearing fingers and thus materially reduce friction between the parts.

The walls of the sockets 15 are projected beyond the adjacent faces of the disks or heads to form reinforcing ribs 17 which assist in retaining the terminal fingers 14 of the arms 13 within said sockets.

The flange 10 of each disk or head is provided with a plurality of vertical slots or recesses 18 which communicate with the sockets 15 and serve to maintain the arms 13 of the springs in spaced relation and prevent accidental displacement of the same.

It will thus be seen that when a downward movement is imparted to the pump rod 8 the upper head or disk 5 will be forced in the direction of the head 6 thus compressing the cushioning members or springs and causing a slight rocking movement of the terminals thereof so that friction or binding action between the parts is reduced to a minimum. By arranging the springs in this manner little, if any strain will be imposed on the wind mill during the up stroke, and during the down stroke the springs will act gradually to cushion the movement of the plunger

rod and thus prevent the jar and noise incident to the operation of devices of this character, as in the ordinary construction.

It will here be noted that the bearing of each spring is on the curved bearing surface 16 of the terminal fingers 14, said fingers being retained in engagement with the walls of the sockets during the operation of the pump by reason of the slots or recesses 18.

10. It will also be noted that the flat bearing surfaces 10' of the disks or heads not only serve to guide the upper head in its vertical movement but by engagement with the posts or standards 11 serve to lock said heads 15 against rotation on the pump rod.

Having thus described the invention what is claimed is:

A pump attachment of the class described comprising spaced heads having concave 20 sockets in their adjoining faces and adjacent the margins thereof, each socket being partly surrounded by a reinforcing rib, and a

flange perpendicular to each head and disposed at the margin thereof, each flange having guide slots extending in the direction of the adjoining sockets and opening thereinto, cushioning springs interposed between the heads and each consisting of diverging arms, a coil at the meeting point between the arms, and terminal portions extending at angles from the arms and having rounded ends bearing against the inner walls of the respective sockets, said slots in the flanges constituting guides for those portions of the arms adjoining the terminals, said arms being normally out of contact with the end walls of the slots.

In testimony that I claim the foregoing as my own, I have hereto affixed my signature in the presence of two witnesses.

GEORGE C. WERNER.

Witnesses:

CHAS. L. BREWSTER,
JOHN GLUNZ.