

19



Europäisches Patentamt  
European Patent Office  
Office européen des brevets



11 Publication number:

**0 284 704 B1**

12

### EUROPEAN PATENT SPECIFICATION

45 Date of publication of patent specification: **09.10.91** 51 Int. Cl.<sup>5</sup>: **E04B 1/343**

21 Application number: **87830410.4**

22 Date of filing: **19.11.87**

54 **Building structure made of prefabricated elements adapted for an easy assembling.**

30 Priority: **30.03.87 IT 1990387**

43 Date of publication of application:  
**05.10.88 Bulletin 88/40**

45 Publication of the grant of the patent:  
**09.10.91 Bulletin 91/41**

84 Designated Contracting States:  
**AT BE CH DE ES FR GB GR LI**

56 References cited:  
**AU-B- 506 666           FR-A- 2 243 307**  
**FR-A- 2 246 706       US-A- 2 647 287**  
**US-A- 2 803 856       US-A- 3 309 115**  
**US-A- 3 432 976**

73 Proprietor: **MODULCASA S.r.l.**  
**Via Rapallo, 2/A**  
**I-43100 Parma(IT)**

72 Inventor: **Reggiani, Barbanzio**  
**MODULCASA S.r.l. Via Rapallo, 2/A**  
**I-43100 Parma(IT)**

74 Representative: **Cicogna, Franco**  
**Ufficio Internazionale Brevetti Dott.Prof.**  
**Franco Cicogna Via Visconti di Modrone,**  
**14/A**  
**I-20122 Milano(IT)**

**EP 0 284 704 B1**

Note: Within nine months from the publication of the mention of the grant of the European patent, any person may give notice to the European Patent Office of opposition to the European patent granted. Notice of opposition shall be filed in a written reasoned statement. It shall not be deemed to have been filed until the opposition fee has been paid (Art. 99(1) European patent convention).

## Description

The present invention relates to a building structure made starting from prefabricated elements adapted to be easily assembled, which has been specifically designed for making temporary houses, stores, garages, school buildings, bars, erecting yard "boxes", beach or bathing huts and civil and industrial constructions in general.

There are presently known buildings made of prefabricated elements which comprise panels adapted to be arranged in an adjoining vertical relationship so as to define the building walls.

More specifically these known panels are vertically arranged on a floor structure, also of the prefabricated type, and, on the top portions of the panels a prefabricated covering structure is mounted.

The known prefabricated element buildings, though they may be assembled in comparatively reduced times, in respect of the conventional type of buildings, require however a comparatively great time and labour amount.

Infact the known prefabricated panels are generally assembled to one another by using screws, bolts or other like coupling means which require a comparatively long assembling time and a very high accuracy by the operator in order to obtain satisfactory results, mainly with respect to the thermal insulation properties.

A prefabricated element building structure having substantially the features of the preamble of the main claim is disclosed in the document US-A-2 647 287.

Thus, the task of the present invention is to overcome the above mentioned drawbacks, by providing a novel prefabricated building structure, which has been specifically designed to reduce to a minimum its assembling time and labour, while assuring a satisfactory thermal insulation from the outside environment.

Within the above task, a main object of the present invention is to provide such a prefabricated element building which is adapted to meet the related safety standards.

Another object of the present invention is to provide a prefabricated element building structure which can also be disassembled in a very reduced time, in respect of the known building structures.

According to one aspect of the present invention, the above mentioned task and objects, as well as yet other objects, which will become more apparent hereinafter, are achieved by a prefabricated element building structure, according to the characterizing part of the main claim.

Further characteristics and advantages of the present invention will become more apparent hereinafter from the following description of a pre-

ferred, though not exclusive embodiment, of a prefabricated element building structure according to the invention, which has been illustrated, by way of an indicative example, in the accompanying drawings, where:

fig.1 is a schematic perspective view of the building structure according to the present invention;

fig.2 is a vertical cross-sectional view illustrating the coupling of a prefabricated panel to a prefabricated covering and prefabricated floor to make the building structure according to the present invention;

fig.3 is a cross-sectional view illustrating the procedure for coupling the covering to a prefabricated panel;

fig.4 is a further cross-sectional view illustrating another possible method for coupling the prefabricated panels, covering and floor to make a building structure according to the invention;

fig.5 is a schematic view illustrating the removable coupling means for coupling two adjoining panels according to the invention;

and

fig.6 illustrates another type of coupling of the panels and covering.

With reference to the figures of the accompanying drawings, the novel building structure according to the invention, which has been indicated overallly at the reference number 1, substantially comprises a floor 2 which defines a substantially horizontal supporting surface, a plurality of prefabricated panels 3 provided for being arranged in a vertical adjoining relationship so as to define the walls of the building structure and a covering 4, which is supported by the top portions of the panels.

The prefabricated panels may be made of wood, or two metal sheets arranged with a facing spaced relationship so as to define, therebetween, a gap to be filled by a thermally insulating material such as foamed polyurethane or the like materials. These panels, in particular, are subjected to a painting operation on their two sides and provided with a reinforcing frame, at least at their top portions to be engaged with the covering 4.

This reinforcing frame may consist, as shown in figure 2, by a metal section member 5a, of substantially C-shape, provided for forced association with the top portion of a panel.

More specifically, said metal section member may be provided with a portion partially extending inside of the panel 3 and having suitable threaded seats or holes 6 for coupling the covering 4 to the top portions or ends of the panels, by means of bolts 7 or self-threading screws.

As shown in figure 4, the reinforcement frame may consist of a metal section member 5b, also of

C-shape, which is provided, on its side supported by the top portions of the panels 3, with a plurality of bores or holes which may be engaged with self-threading screws 8 for coupling the covering 4 and panels 3.

According to a further embodiment of the present invention, which has been schematically shown in figure 6, the reinforcement frame may consist of a metal section member 5c, also of C-shaped cross-section, which is affixed by riveting to the panel 3 and which is engaged with the covering 4 by means of a plurality of self-threading screws 9.

Advantageously, in order to provide a proper stability of the covering 4-panel 3 coupling, there are provided bracket members 10 which are associated, by riveting or self-threading screws, with the covering 4 and panel 3 bodies.

Further advantageously, each panel 3 is provided, at its lower or bottom portion, with a metal plate 11 which is at least partially embedded in the body of the panel and which is provided with a portion to be supported by the floor and rigidly associated therewith, by means of a plurality of self-threading screws 12, or rivets, bolts and the like.

According to the present invention, in order to engage two adjoining panels, there are provided removable coupling means, indicated overall at the reference number 13 which, in the embodiment being disclosed, substantially consist of a hook 14 which laterally projects from a panel and may be engaged with a lug member 15 provided at one side end of the adjoining panel.

Advantageously, on the hook 14 a cam member 16 operates which may be rotated, upon assembling, to move away the hook 14 from the lug member 15, so as to clamp the two panels and lock the hook 14, in the closure position, on the lug 15.

At the perimeter of the covering 4 there is provided a band 17, made for example of a sheet metal, which is associated with the covering by means of bracket 18.

Under the band 17 a gutter 21 is arranged which, for example, is made of vinyl chloride or the like material and is affixed to suitable attaching regions formed on the outer side of the panel 3 reinforcement frame.

Advantageously, in order to provide proper sealing properties, at the junction zone of two panels there is arranged a sealing material band, made for example of a foamed material, which is compressed as the panels are assembled.

In particular, the floor 1 may also be of the prefabricated type, or consist of a steel tube structure supporting a plurality of horizontally arranged panels, some of which may be already provided with the related doors 19 and windows 20.

The building structure according to the present

invention may be assembled by the following method.

After having arranged horizontally the floor 2, the panels 3 are mounted on said floor and are coupled to one another by coupling the hook 14 and lug 15, by rotating the cam member 16.

Then the panels 3 are rigidly engaged with the floor 2 and the covering 4 is arranged thereon, said covering being successively affixed to the panels 3: finally there are mounted finishing elements, such as the gutter 21.

From the above disclosure it should be apparent that the invention fully achieves the intended task and objects.

More specifically, it should be apparent that the provision of the removable coupling means affords the possibility of assembling, in a quick and simple way, the prefabricated panels to make the walls of building structures, which structures are quickly and easily completed by applying the covering, through the use of self-threading screws or the like means.

Moreover the building structures may also be disassembled in a correspondingly quick and easy way.

Another advantage of the present invention is that it affords the possibility of quickly and easily making building structures having a good aesthetic finishing.

In practicing the invention, the used materials, provided that they are compatible to the intended use, as well the specific size and shapes may be any according to requirements.

### Claims

1. A prefabricated element building structure, adapted for being assembled in a quick and easy way, comprising a floor defining a supporting surface for a plurality of prefabricated panels, to be arranged in a vertical adjoining relationship so as to define the walls of the building structure, a covering to be supported on the top portions of said panels, and hook means (14) for removably coupling two adjoining of said panels to be said floor and covering, said hook means comprising a hook member including a curved end portion and projecting from one side of one of said panels and provided for engagement with a lug member (15) formed on the adjoining panel, characterized in that said hook member comprises an end slot in which a stud member rigid with said one panel is slidably engaged, said slot having a longitudinal axis forming a given acute angle with a horizontal line, in that said lug member is rigid with the other of said panels and in that on said one of said panels there being provided a cam spring member (16) adapted for

engaging the outer surface of said hook member (14) and moving it away from said lug member (15) and locking it thereon.

2. A prefabricated element building structure, according to claim 1, characterized in that each said panel is provided, at least at the top thereof, with an outer reinforcing substantially U or C-shaped frame (5a, 5b), which is rigidly associated with at least one edge of the panel so as to protect said edge from impacts and adapted for association, by means of self-threading screws (7), with said covering. 5 10
3. A prefabricated element building structure according to one or more of the preceding claims, characterized in that said panels are provided, at their bottom portions, with plate members embedded in said panel bodies and adapted for being rigidly associated with said floor. 15 20
4. A prefabricated element building structure, according to claim 2, characterized in that said reinforcement frame is provided, on its outer side, with attachment regions to be engaged with a gutter arranged at the bottom of said covering. 25
5. A prefabricated element structure, according to claim 4, characterized in that said covering is provided with a perimetrical band which is arranged at said gutter. 30

#### Revendications 35

1. Structure de bâtiment en panneaux préfabriqués, apte à être assemblée d'une manière simple et rapide, comprenant un plancher définit une surface de support pour une pluralité de panneaux préfabriqués, à être disposés d'une relation de contact vertical, de façon de définir les parois de la structure de bâtiment, un plafond ou couverture à être supporté sur les portions supérieures desdits panneaux, et moyens à croc (14) pour accoupler d'une manière movable deux desdits panneaux adjacents qui deviennent ledit panneau et plafond, lesdits moyens à croc comprenant une portion finale courbée et projetant d'un côté desdits panneaux et prévue pour s'engager avec un élément saillant (15) formé sur le panneau adjacent, caractérisée en ce que ledit élément à croc comprend une fente à l'extrémité où un élément en forme de clou ou de bouton raccordé rigidement avec ledit premier panneau est engagé coulissant, ladite fente présentant un axe longitudinal formant un angle déterminé 40 45 50 55

aigu avec une ligne horizontale, en ce que ledit élément saillant est raccordé rigidement avec l'autre desdits panneaux, et en ce que sur l'un desdits panneaux il y a prévu un élément en forme de ressort à came (16) apte à engager la surface extérieure dudit moyen à croc (14) et l'enlever dudit élément saillant (15) et le serrer sur lui.

2. Structure de bâtiment en panneaux préfabriqués, selon la revendication 1, caractérisée en ce que chacun desdits panneaux est muni, au moins sur son extrémité supérieure, d'un cadre de renforcement extérieur, essentiellement en forme de U ou de C (5a, 5b), qui est rigidement associé au moins avec un coin du panneau de façon de protéger ledit coin des impacts et apte à être associé, au moyen de visse autotaradeuses (7), audit plafond.
3. Structure de bâtiment en panneaux préfabriqués, selon l'une ou plusieurs des revendications précédentes, caractérisée en ce que lesdits panneaux sont munis, sur leur portions de fond, d'éléments plats incorporés dans lesdits panneaux et aptes à être rigidement associés audit plancher.
4. Structure de bâtiment en panneaux préfabriqués, selon la revendication 2, caractérisée en ce que ledit cadre de renforcement est muni, sur son côté extérieur de régions d'attaque pour s'engager avec une rainure ou égout arrangée au fond de ladite couverture.
5. Structure de bâtiment en panneaux préfabriqués, selon la revendication 4, caractérisée en ce que ladite couverture ou plafond est muni d'un bord périmétrale arrangé sur ladite rainure ou ledit égout.

#### Patentansprüche

1. Gebäudestruktur aus vorgefertigten, für einen leichten Zusammenbau angepassten Elementen, mit einem eine für mehrere vorgefertigten Elementen Lagerfläche bestimmenden Boden, wobei diesen Elemente um den Wände der Gebäudestruktur zu bestimmen, vertikal anliegend stehen; mit einer Bedeckung zur Bestützung auf der obengenannten Oberteile der obengenannten Elementen; und mit Hakenelementen (14) zur bewegliche Verbindung der obengenannten anliegenden Elementen die die obengenannten Wand und Bedeckung werden, wobei die obengenannten Hakenelemente einen Hakenteil weist auf, der mit einer gekrümmten und seitlich mit bezug auf den obi-

- gen Elementen vorspringenden Endportion zum Einklinken mit einer auf den anliegende Elemente gebildeten Vorsprung vorgesehen ist,  
dadurch gekennzeichnet, dass der obengenannte Hakenteil, am Ende wo eine mit dem obengenannten ersten Element festverbundenen Vorsprung verschiebbar einklinkt, eine Schlitz weist auf, die eine Längachse verseht, die ein horizontalliegende bestimmte Spitzwinkel bildet; dass die obengenannte Vorsprung mit dem anderen Element festverbunden ist; und  
dass auf den obengenannte Element einen Federkurvenelement (16) verseht, das mit der äusseren Fläche des obengenannten Haken-element (14) und dieselbe aus der obengenannten Vorsprung (15) und auf dasselbe einzusperrern geeignet ist.
2. Gebäudestruktur aus vorgefertigten Elementen, nach Anspruch 1, dadurch gekennzeichnet, dass jedes Gebäudeelement wenigstens auf seinem oberen Ende, mit einem äusseren wesentlich U- oder C-förmigen Versteifungsrahmen (5a, 5b), der mit wenigstens einer Kante des Elementes um dieselbe Kante gegen Stossen zu stützen festverbunden ist, und mittels selbstgewindenden Schrauben (7) zum Verbunden mit der obengenannten Bedeckung geeignet ist.
3. Gebäudestruktur aus vorgefertigten Gebäudeelementen, nach einem oder mehreren der vorhergehenden Ansprüchen, dadurch gekennzeichnet, dass die obengenannten Elemente, auf ihren Unterportionen, mit in den obengenannten Elementen eingebauten Flachteilen vorgesehen sind, die zur Festverbinding mit dem obengenannten Boden geeignet sind.
4. Gebäudestruktur aus vorgefertigten Gebäudeelementen, nach Anspruch 2, dadurch gekennzeichnet, dass der obengenannte Versteifungsrahmen, auf seinen äusseren Seite, mit Anbringungs-zonen für eine am Boden der obengenannten Bedeckung angeordnete Dachrinne vorgesehen ist.
5. Gebäudestruktur aus vorgefertigten Gebäudeelementen, nach Anspruch 4, dadurch gekennzeichnet, dass die obengenannte Bedeckung mit einem auf die obengenannte Dachrinne angeordneten Umfangstreifen vorgesehen ist.

5

10

15

20

25

30

35

40

45

50

55

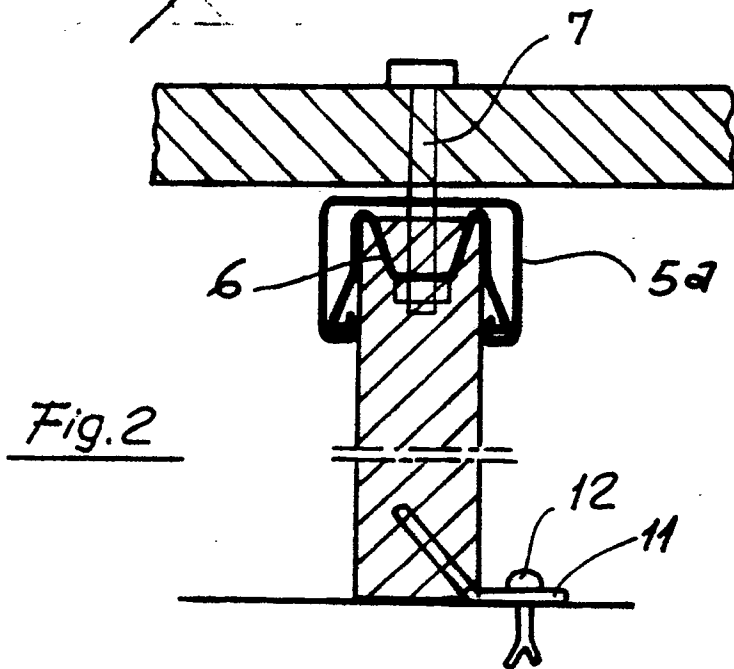
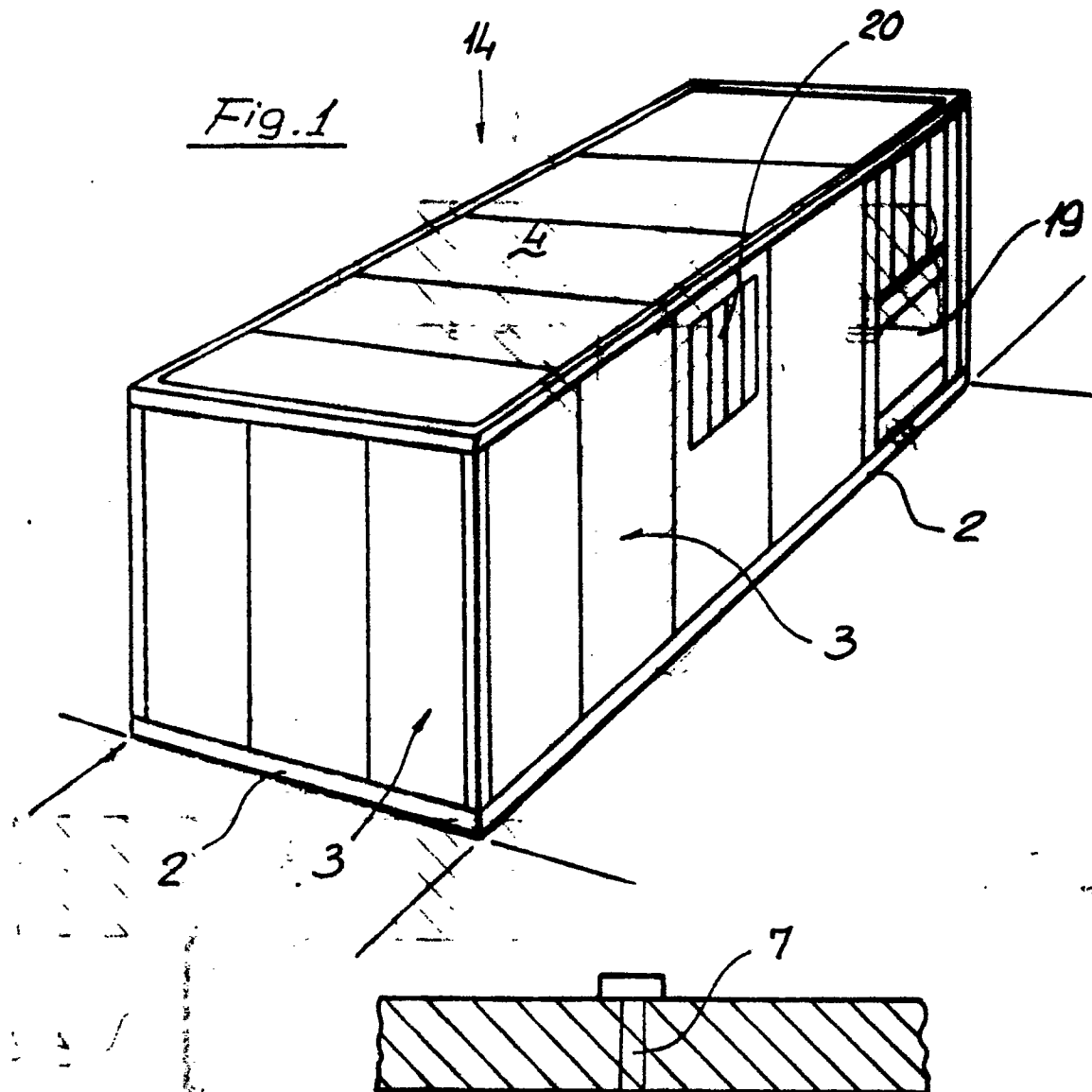

Fig. 3

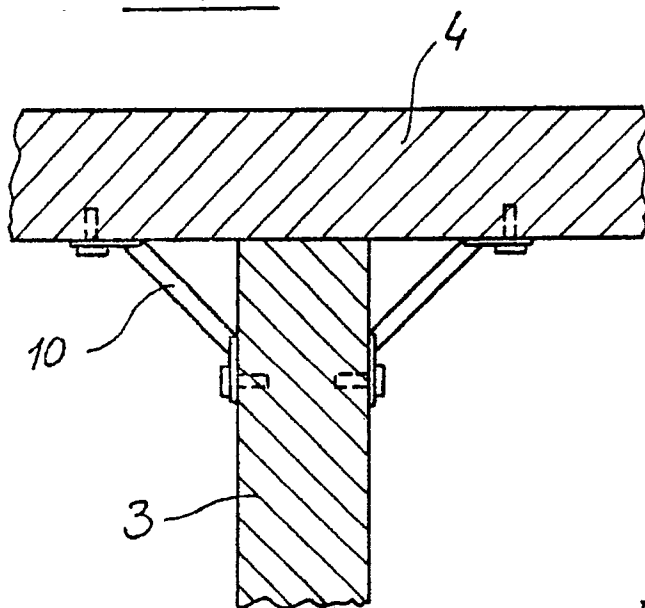

Fig. 4

