

(19) **DANMARK**



Patent- og
Varemærkestyrelsen

(10) **DK/EP 3140512 T3**

(12) **Oversættelse af
europæisk patentskrift**

-
- (51) Int.Cl.: **E 21 D 11/38 (2006.01)** **E 21 D 11/08 (2006.01)**
- (45) Oversættelsen bekendtgjort den: **2023-04-24**
- (80) Dato for Den Europæiske Patentmyndigheds bekendtgørelse om meddelelse af patentet: **2023-03-22**
- (86) Europæisk ansøgning nr.: **15718948.1**
- (86) Europæisk indleveringsdag: **2015-05-01**
- (87) Den europæiske ansøgnings publiceringsdag: **2017-03-15**
- (86) International ansøgning nr.: **EP2015059619**
- (87) Internationalt publikationsnr.: **WO2015169707**
- (30) Prioritet: **2014-05-06 NL 2012765**
- (84) Designerede stater: **AL AT BE BG CH CY CZ DE DK EE ES FI FR GB GR HR HU IE IS IT LI LT LU LV MC MK MT NL NO PL PT RO RS SE SI SK SM TR**
- (73) Patenthaver: **Trelleborg Ridderkerk B.V., Verlengde Kerkweg 15, 2985 AZ Ridderkerk, Holland**
- (72) Opfinder: **VAN STEE, Joël Emmanuel, Verlengde Kerkweg 15, 2985 AZ Ridderkerk, Holland**
- (74) Fuldmægtig i Danmark: **Novagraaf Brevets, Bâtiment O2, 2 rue Sarah Bernhardt CS90017, F-92665 Asnières-sur-Seine cedex, Frankrig**
- (54) Benævnelse: **FREM GANGSMÅDE TIL FREMSTILLING AF ET KONSTRUKTIONSELEMENT, ISÆR ET TUNNELEMENT, MED EN VANDTÆT TÆTNING**
- (56) Fremdragne publikationer:
EP-A1- 2 666 959
EP-A2- 1 054 204
WO-A1-98/16721
WO-A2-2013/053452
DE-A1- 3 800 630
FR-A1- 2 712 655
GB-A- 2 251 203
JP-A- 2005 146 698
Trelleborg Ridderkerk: "Gina Gasket Contents", , 13 November 2009 (2009-11-13), XP055154208, Retrieved from the Internet: URL:[http://www.trelleborg.com/upload/Infra structure/Files/Gina Gasket.pdf](http://www.trelleborg.com/upload/Infra%20structure/Files/Gina%20Gasket.pdf) [retrieved on 2014-11-20]

DESCRIPTION

[0001] The invention relates to a method for producing a tubular tunnel element from concrete, in a mould, for an immersed tunnel wherein the tubular tunnel elements are placed against one another with a water tight seal in between the outer ends thereof, said tubular tunnel element being provided with a watertight seal on at least one outer end thereof, wherein an endless gasket is produced comprising a deforming body which is produced from a yielding material, such as rubber, and a base which is produced from a relatively strong material.

[0002] An immersed tunnel is normally constructed from structural concrete elements approximately 100-150 meters long, which are manufactured in a casting basin or dry dock. The tunnel elements are provided with temporary bulkheads at both ends to ensure that the element is watertight and capable of floating. On one end of each tunnel element, an endless gasket is mounted. When manufacturing of the tunnel elements is completed, the dock is flooded and the elements floated. Each element is towed to its final position and then immersed. The immersed tunnel element is then pulled firmly up against the preceding immersed element with hydraulic jacks. The initial contact of the gasket should be accomplished using a low pulling force. When the gasket has full contact around the total circumference of the adjacent element, the water between the bulkheads is pumped out. Due to pressure differential between the bulkheads and the hydrostatic pressure on the outside of the tunnel, the gasket profile compresses and seals the joint. A secondary seal is then clamped across the joint on the inside of the tunnel. In general the bulkheads are removed after approval of the pressure test between the gasket and the secondary seal.

[0003] The supplier of the gasket needs to show by calculations based on the measured force-compression curves that at all water pressures the selected gasket satisfies the following conditions within agreed safety limits:

1. 1. transfer of the hydrostatic loads at high water level is within the maximum compression capacity of the gasket profile;
2. 2. sealing at all water levels for all joints, including the effect of gap variations due to variation in smoothness/flatness of the tunnel faces, rotation of immersed tunnel elements, creep and shrinkage of the concrete material and temperature effects;
3. 3. restoring moments to re-align misalignment of a tunnel element;
4. 4. proper functioning of the gasket after re-alignment with respect to prevention of leakage at the gap opening side and prevention of overload at the gap closing side;
5. 5. sealing properties should incorporate the effect of relaxation on the rubber material of the seal over the tunnel life time period; and
6. 6. the gasket flange construction should be able to withstand additional loads without dislocation, due to shear of the compressed gasket in case of differential tunnel settlement.

[0004] According to prior art methods, such as for instance disclosed in the brochure "Gina Gasket, Trelleborg Ridderkerk B.V." (published in 2009), the gaskets are mounted on the ends of the tunnel element using an end frame which is first attached to the ends of the tunnel element, and then one side of the gasket is mounted in the frame. The end frame is usually made of carbon steel or stainless steel. Mounting the end frames to the tunnel elements and mounting the gasket in the frames is however time consuming.

[0005] The aim of the invention is to provide a cheap, reliable and fast manner to produce and place construction elements such as tunnel elements.

[0006] According to the invention the base is provided with anchors made of metal or carbon on one side thereof, the base with the deforming body is placed against an inner side of the mould, wherein the concrete is cast in the mould, and the anchors extend into the concrete while the concrete is cured to form the tubular tunnel element with the watertight seal. In this manner the steel end-frames are eliminated and separate installation of the gasket is no longer required. Because said base is provided with anchors on one side thereof, said anchors extending into the curing material while said material is cured, a chemical and or mechanical bond can be obtained.

[0007] EP 1 054 204 A2 discloses concrete tubular sewer pipe elements with a rubber seal, wherein a rubber anchor part of the seal is enclosed in the curing concrete. The engaging ends of the sewer pipes are mutually mechanically locked in a form-fitted manner in their lateral/radial direction.

[0008] In a first further preferred embodiment said anchors extend from a plate which is at least partially surrounded by said yielding material of the gasket in order to hold said plate. Said plate is also preferably made of metal or carbon. Said anchors comprise bolts, which are screwed into said plate so as to extend therefrom.

[0009] In a second further preferred embodiment said anchors are plate shaped, wherein said plate shaped elements extend in the curing material parallel to a surface of the curing material.

[0010] The invention also relates to a tunnel element produced by the method as described before.

[0011] The invention furthermore relates to a tunnel wherein tubular tunnel elements produced by the method as described before are placed against one another with said seal in between the outer ends thereof. Preferably a secondary seal is provided over said seal against the inner side of said tunnel.

[0012] The invention will now be elucidated by means of embodiments, as shown in the drawings, wherein:

Figure 1 shows a cross section of an immersed tunnel being built from tunnel elements;

Figure 2 is a perspective view of detail of an outer end of a tunnel element as indicated by arrow II in figure 1;

Figures 3, 4, 5 and 6 show various stages of the process of placing and sealing the outer ends of the tunnel elements of figure 1;

Figure 7 is a detail of the cross section as shown in figure 6 showing a prior art seal;

Figure 8 is a detail of the cross section as shown in figure 6 showing a seal;

Figure 9 is a sectional cross section of the seal as shown in figure 8 before the outer ends of the tunnel elements are placed and sealed;

Figure 10 is a longitudinal cross section of the seal as shown in figure 8 before the outer ends of the tunnel elements are placed and sealed;

Figures 11, 12 and 13 are sectional cross sections of alternative embodiments of seals.

[0013] According to figure 1 an immersed tunnel is constructed from structural concrete tunnel elements 1. The tunnel elements 1 are provided with temporary bulkheads 2 at both ends to ensure that the element is watertight and capable of floating. Each tunnel element 1 is towed to its final position and then immersed. As shown in figures 2 and 3, on one end of each tunnel element 1, an endless gasket 3 is mounted. The immersed tunnel element 1 is pulled firmly up against the preceding immersed tunnel element 1, as shown in figure 4. When the gasket 3 has full contact around the total circumference of the adjacent tunnel element 1, the water between the bulkheads 2 is pumped out as shown in figure 5. Due to pressure differential between the bulkheads 2 and the hydrostatic pressure on the outside of the tunnel elements 1, the gasket profile compresses and seals the joint. A secondary seal 4 is then clamped across the joint on the inside of the tunnel elements 1. The bulkheads 2 are then removed as shown in figure 6.

[0014] Figure 7 shows a prior art seal of the joint between two tunnel elements 1. In this embodiment the endless gasket 3 is profiled, having a base mounting portion 31 and a compressing body 32.

[0015] Between the mounting portion 31 and the compressing body 32 a slot is provided at both sides of the gasket 3, in which metal strips can engage in order to hold the gasket 3.

[0016] According to the prior art, the method for mounting the gasket to the tunnel element 1 is as follows. First an end-frame 5 is provided on the outer end of the cured concrete tunnel element 1. Then the endless gasket 3 is laid out in the correct rectangular shape, flat on a floor (for instance the roof of the tunnel element 1. A lifting beam with nylon straps engages the top section and the lower section of the gasket 3, and the gasket 3 is lifted to the vertical position. The gasket 3 is placed in front of and against the end-frame 5 on the outer end of the tunnel

element 1, and on both side of the gasket 3 a metal hooked profiled mounting strip 6 is inserted in the slot between the mounting portion 31 and the compressing body 32, whereafter the mounting strips 6 are attached to the end-frame 5 by means of bolts.

[0017] The gasket 3 is directly casted with the tunnel element, eliminating the steel end-frame 5 and mounting strips 6 as shown in figure 7. Separate installation is no longer required. The gasket 3 is placed in a special mould. This mould is used to cast the front section of the tunnel element 1. After curing of the concrete and releasing of the mould the gasket 3 is permanently connected with the tunnel element 1.

[0018] In the embodiment of figures 8, 9 and 10 the gasket 3 comprises an endless compressing body 32 made from vulcanized rubber. The compressing body has a generally rectangular, almost square and slightly tapering, cross section. On the side of the compressing body 32 intended to contact the opposing tunnel element 1, which is the smallest of the two opposing sides, a rib 33 is formed which can be easily be deformed upon first contact with the opposing tunnel element 1. On the other side, which is the largest of the two opposing sides, base elements 34 comprising plate shaped elements 341 are enclosed in the rubber material near or at the surface of the compressing body 32. In this embodiment the base elements 34 and the deforming body 32 are not detachable from each other thereby. In this example the plate shaped element 341 is made of carbon fibre or fabric inlay material. Over the length of the plate shaped element 34 pairs of bolts 342 with bolt heads are screwed through the plate shaped element 341, so as to form anchors. On the other side of the plate shaped elements 34 the bolts 342 are secured by nuts 343. The base elements 34 together with the deforming body 32 are cast integral with the concrete.

[0019] In the embodiment of figure 11 the gasket 3 comprises an endless compressing body 32 made from vulcanized rubber. The compressing body 32 has a generally rectangular, almost square and slightly tapering, cross section. On the side of the compressing body 32 intended to contact the opposing tunnel element 1, which is the smallest of the two opposing sides, a rib 33 is formed which can be easily be deformed upon first contact with the opposing tunnel element 1. On the other side, which is the largest of the two opposing sides, plate shaped mounting elements 321 are formed integral with the compressing body 32. Base elements 34 in the form of plate shaped elements are cast integral with the concrete of the tunnel elements. The base 34 and the compressing body 32 are detachable from each other and are attached to each other by means of screws 35.

[0020] In the embodiment of figure 12 the gasket 3 comprises an endless compressing body 32 made from vulcanized rubber. The compressing body 32 has a generally rectangular, almost square and slightly tapering, cross section. On the side of the compressing body 32 intended to contact the opposing tunnel element 1, which is the smallest of the two opposing sides, a rib 33 is formed which can be easily be deformed upon first contact with the opposing tunnel element 1. On the other side, which is the largest of the two opposing sides, the compressing body is formed with a base mounting portion 31. Between the mounting portion 31 and the compressing body 32 a slot is provided at both sides of the compressing body 32,

in which metal strips can engage in order to hold the compressing body 32. Base elements 34 comprising plate shaped elements 341 are cast integral with the concrete of the tunnel elements. The base element 34 further comprises a metal hooked profiled mounting strip 347 mounted on the plate shaped element 341 which can be inserted in the slot between the mounting portion 31 and the compressing body 32. The base 34 and the compressing body 32 are thus detachable from each other and are attached to each other by means of a separate metal hooked profiled mounting strip 37 which can be mounted on the plate shaped element 341 by means of screws 35.

[0021] In the embodiment of figure 13 the gasket 3 comprises an endless compressing body 32 made from vulcanized rubber. The compressing body 32 has a generally rectangular, almost square and slightly tapering, cross section. On the side of the compressing body 32 intended to contact the opposing tunnel element 1, which is the smallest of the two opposing sides, a rib 33 is formed which can be easily be deformed upon first contact with the opposing tunnel element 1. On the other side, which is the largest of the two opposing sides, plate shaped mounting elements 321 are formed integral with the compressing body 32, on both sides of the centre line. On the centre line of said side a V-shaped recess is provided, which allows for manual inward compression of the sides of the compressing body. Base elements 34 comprising plate shaped elements 341 are cast integral with the concrete of the tunnel elements. From the edges of the plate shaped element 341 extend strips 348 in the direction of the central-top part of the compressing body. The base 34 and the compressing body 32 are detachable from each other and are attached to each other by compressing the lower part of the compressing body 32 such that it can snap behind the edges of the strips 348 as shown in figure 13.

[0022] Apart from immersed tunnels, the invention also applies to other construction elements, such as:

Dry dock sealing: dock doors are closed and opened either mechanical or due to hydrostatic water pressure. The pressure acting on the gaskets mounted on these doors are compressing the gasket resulting in a watertight seal.

Storm surge barriers.

Offshore mooring devices. Seals are mounted on a flat surface in a closed circuit connected to a ships hull result into a differential pressure. This differential pressure is used to keep the mooring device in place and connected through a "soft" joint.

Grout sealing. The seal is used to create a void which can be grouted. Once the grout has hardened the seal becomes obsolete.

General sealing purposes.

REFERENCES CITED IN THE DESCRIPTION

Cited references

This list of references cited by the applicant is for the reader's convenience only. It does not form part of the European patent document. Even though great care has been taken in compiling the references, errors or omissions cannot be excluded and the EPO disclaims all liability in this regard.

Patent documents cited in the description

- EP1054204A2 [0007]

Non-patent literature cited in the description

- **GINA GASKETT**Trelleborg Ridderkerk B.V., 2009, [0004]

PATENTKRAV

1. Fremgangsmåde til fremstilling af et rørformet tunnelement (1) ud fra beton, i en støbeform, til en sænketunnel, hvor de rørformede tunnelementer placeres mod hinanden med en vandtæt tætning imellem de ydre ender deraf, idet
5 det rørformede tunnelement (1) forsynes med en vandtæt tætning på mindst én ydre ende deraf,

hvor der fremstilles en endeløs pakning (3), der omfatter en deformeringskrop (32), som fremstilles ud fra et eftergivende materiale, såsom gummi, og en basis (34), som fremstilles ud fra et relativt stærkt materiale;

10 **kendetegnet ved, at**

basen (34) forsynes med ankre (342), som fremstilles af metal eller carbon, på den ene side deraf, idet basen (34) med deformeringskroppen (32) placeres mod en inderside af støbeformen, hvor betonen støbes i støbeformen, og

15 ankrene (342) strækker sig ind i betonen, mens betonen hærdes til dannelse af det rørformede tunnelement (1) med den vandtætte tætning.

2. Fremgangsmåde ifølge krav 1, hvor ankrene (342) strækker sig fra en plade (341), der mindst delvist er omgivet af pakningens eftergivende materiale med henblik på at fastholde pladen.

3. Fremgangsmåde ifølge krav 2, hvor pladen (341) fremstilles af metal eller
20 carbon.

4. Fremgangsmåde ifølge krav 2 eller 3, hvor ankrene (342) omfatter bolte, der indskrues i pladen (341) med henblik på at strække sig derfra.

5. Fremgangsmåde ifølge et hvilket som helst af de foregående krav 1-4, hvor ankrene (342) er pladeformet, hvor de pladeformede elementer strækker sig i
25 det hældende materiale parallelt med en overflade af det hældende materiale.

6. Rørformet tunnelement (1), der fremstilles ved hjælp af fremgangsmåden ifølge et hvilket som helst af de foregående krav.

7. Tunnel, hvor rørformede tunnelelementer (1), der fremstilles ved hjælp af fremgangsmåden ifølge et hvilket som helst af de foregående krav, placeres mod hinanden med tætningen imellem de ydre ender deraf.
8. Tunnel ifølge krav 7, hvor der anbringes en sekundær tætning (4) hen
5 over tætningen mod tunnellens inderside.

DRAWINGS

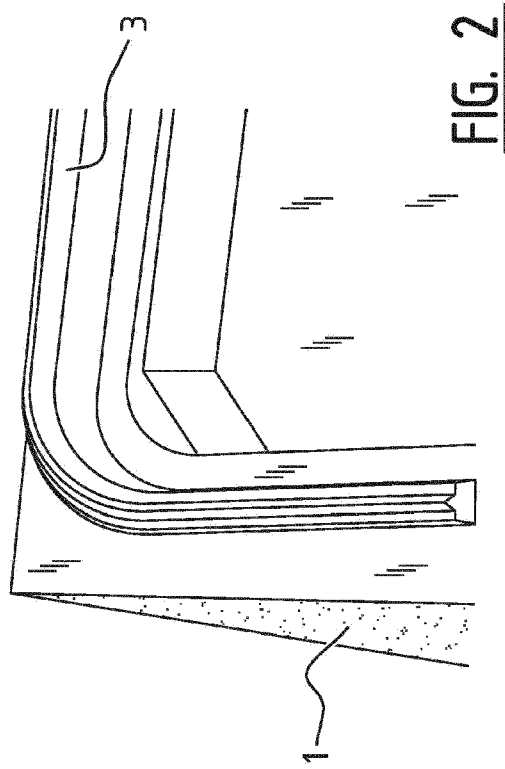
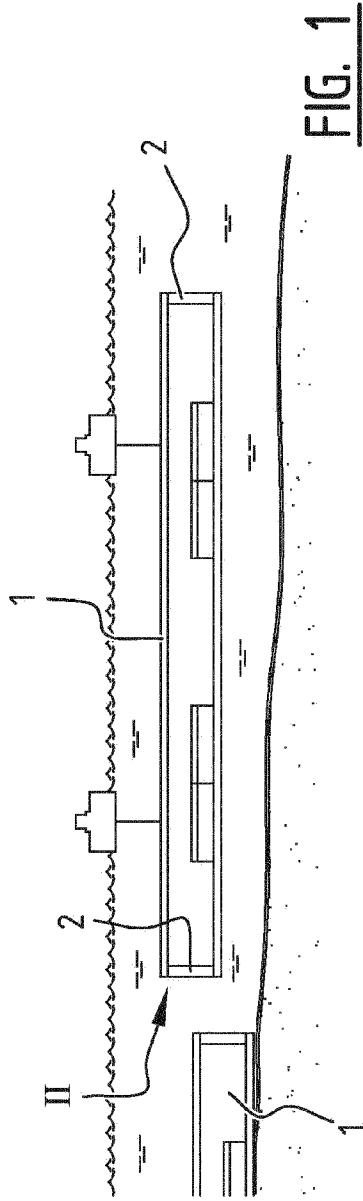

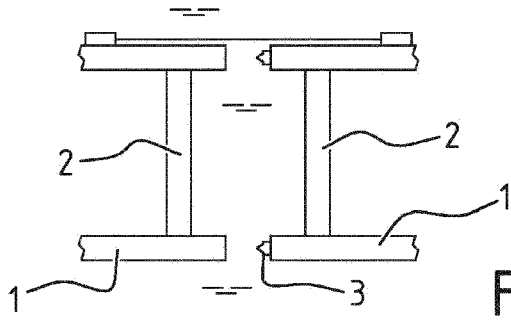

FIG. 3

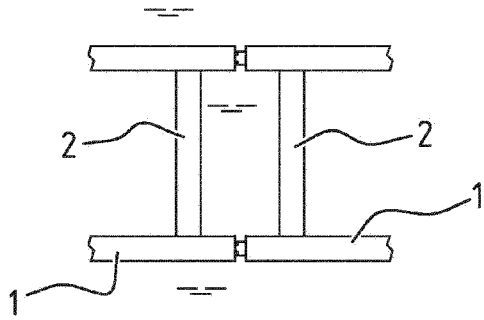

FIG. 4

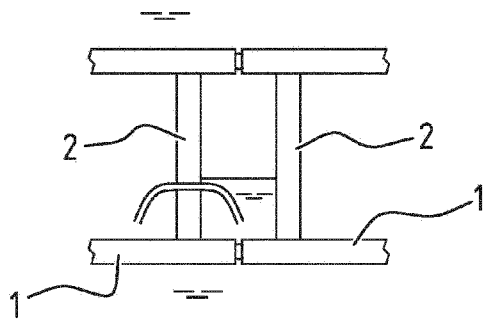

FIG. 5

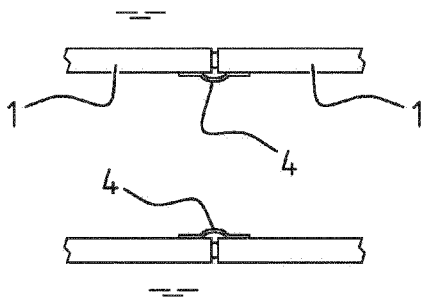

FIG. 6

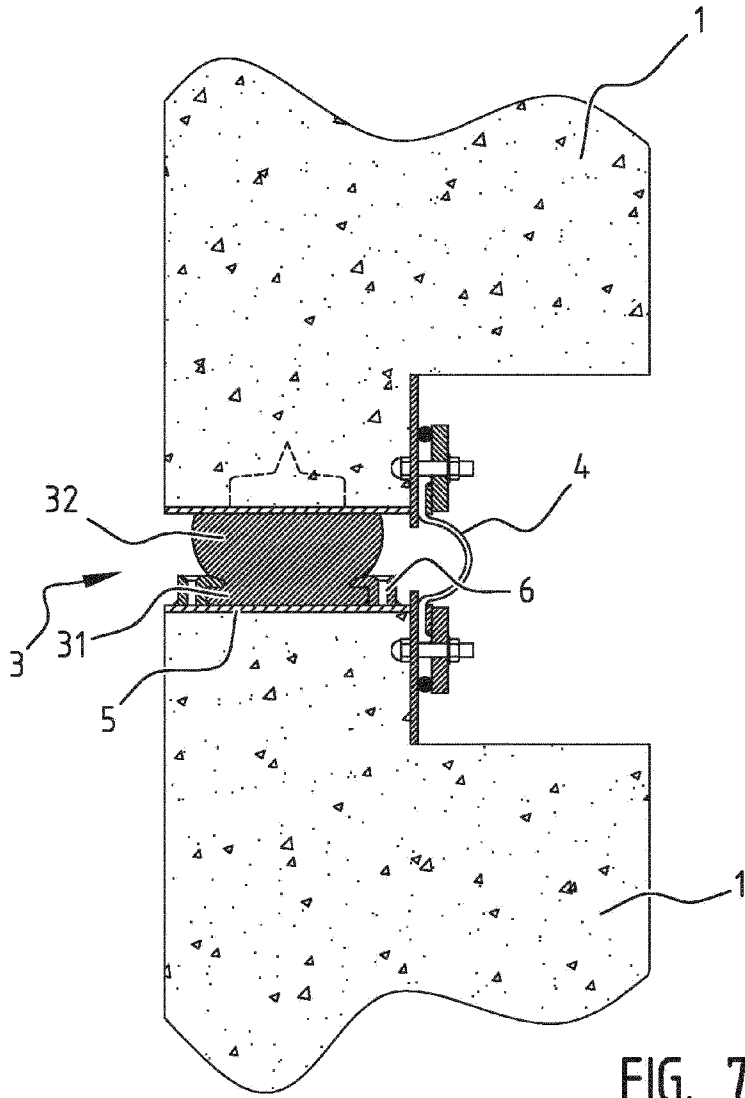

FIG. 7

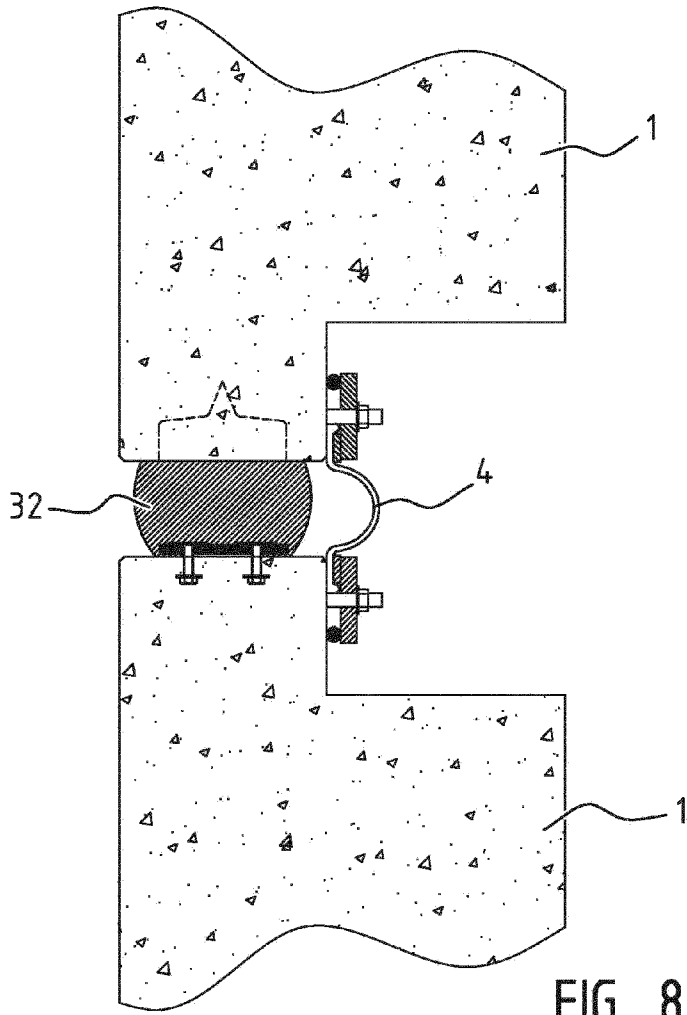
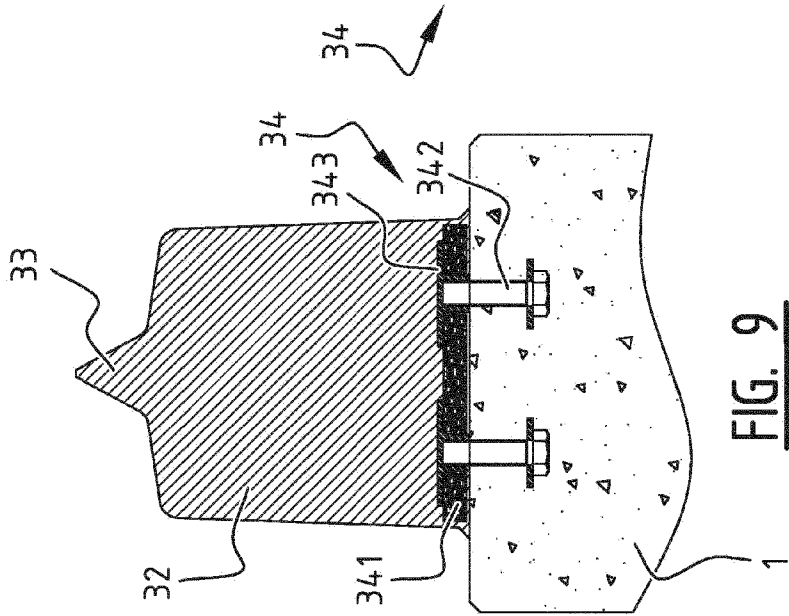
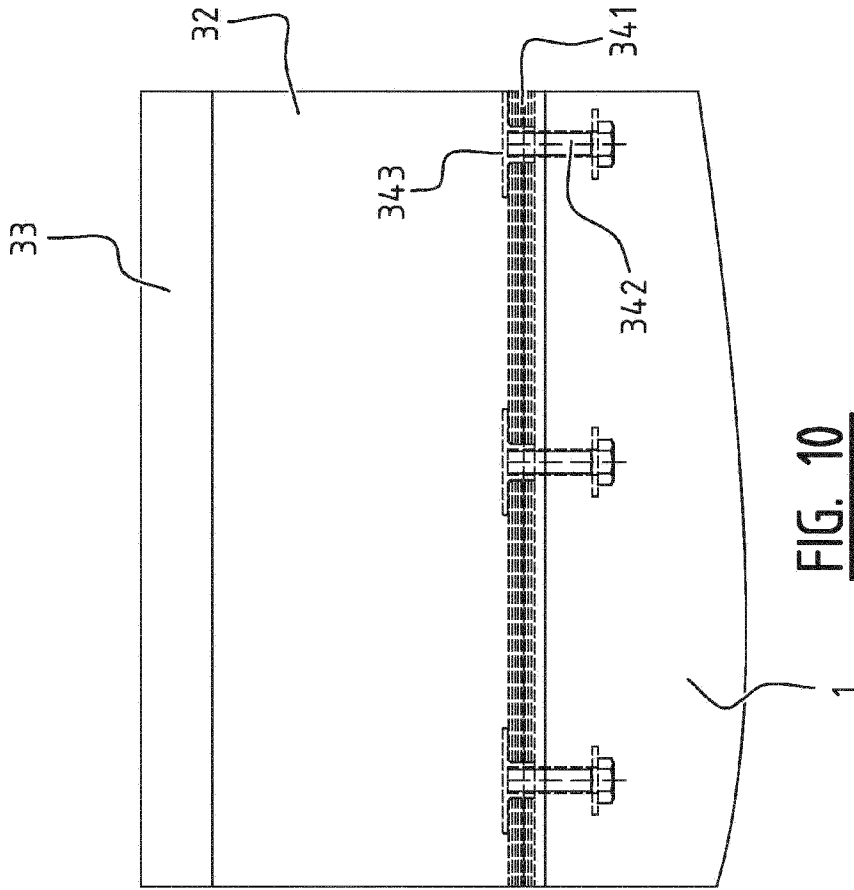

FIG. 8



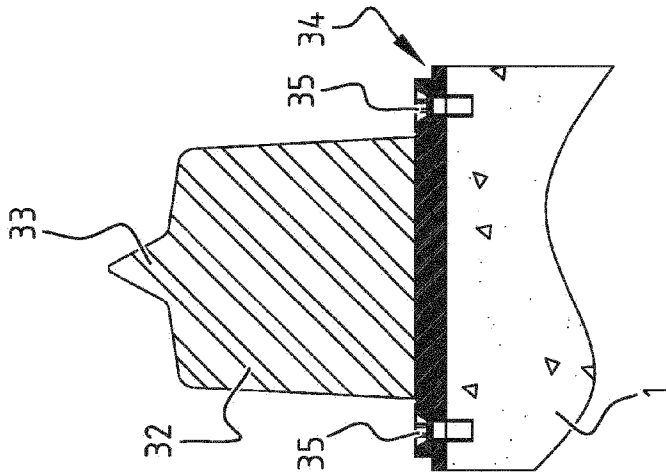

FIG. 11

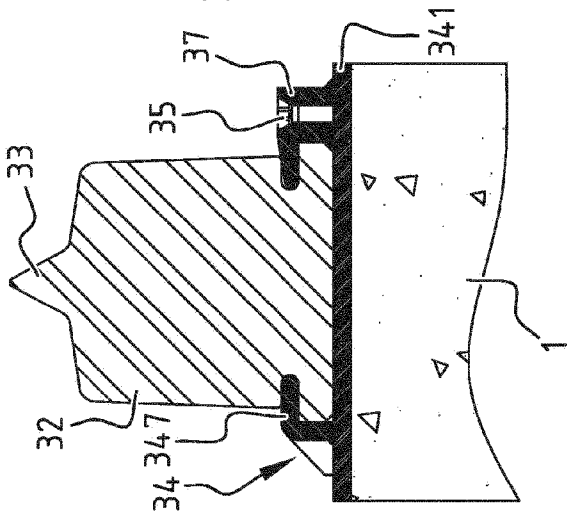

FIG. 12

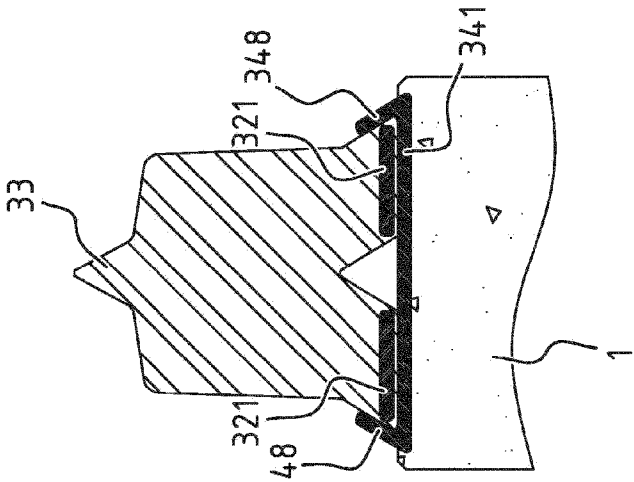

FIG. 13