

J. DUNFEE.  
 DOUBLE FAGER FOR CORRUGATED PAPER MACHINES.  
 APPLICATION FILED OCT. 7, 1910.

982,176.

Patented Jan. 17, 1911.

3 SHEETS—SHEET 1.

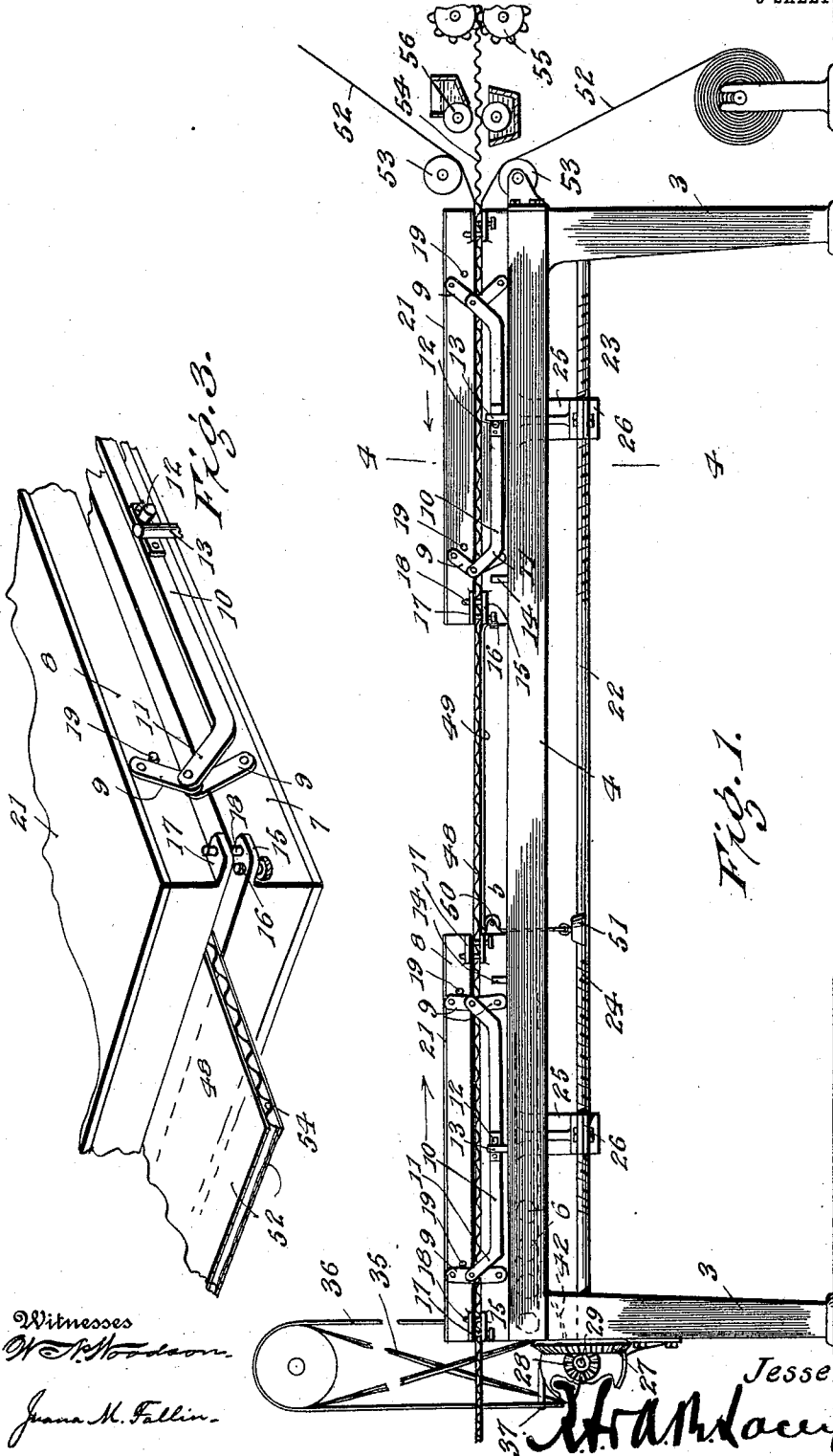

Witnesses  
*W. P. Hodson*  
*J. M. Fallon*

Inventor

Jesse Dunfee

*W. H. Macy*, Attorneys.

J. DUNFEE.  
 DOUBLE FACER FOR CORRUGATED PAPER MACHINES.  
 APPLICATION FILED OCT. 7, 1910.

982,176.

Patented Jan. 17, 1911

3 SHEETS—SHEET 2.

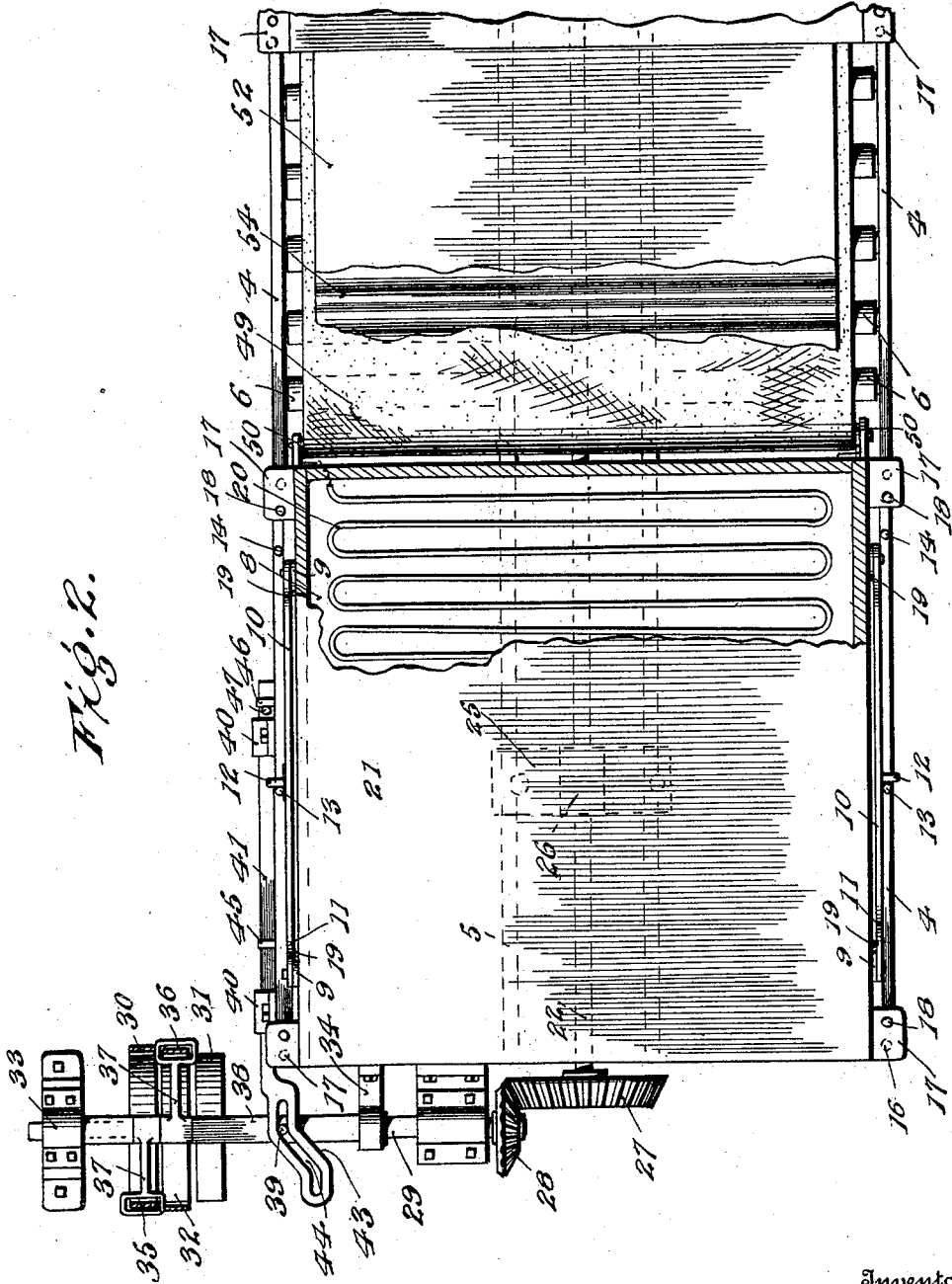

*Fig. 2.*

Inventor

*Jesse Dunfee*

Witnesses  
*W. Woodson*

*Jane M. Fullin*

384

*H. Anderson* Attorneys.

J. DUNFEE.  
 DOUBLE FACER FOR CORRUGATED PAPER MACHINES.  
 APPLICATION FILED OCT. 7, 1910.

982,176.

Patented Jan. 17, 1911.

3 SHEETS—SHEET 3.

Fig. 4.

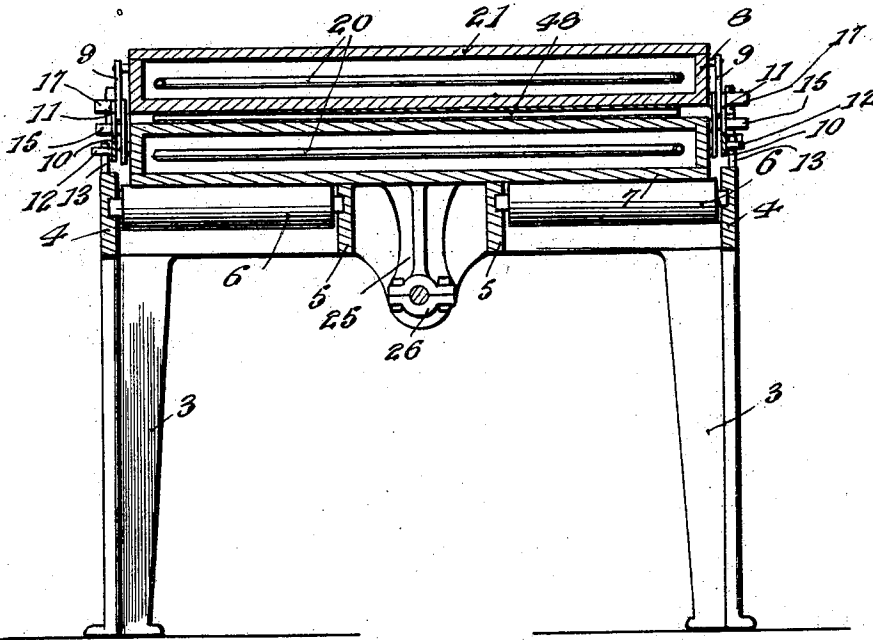
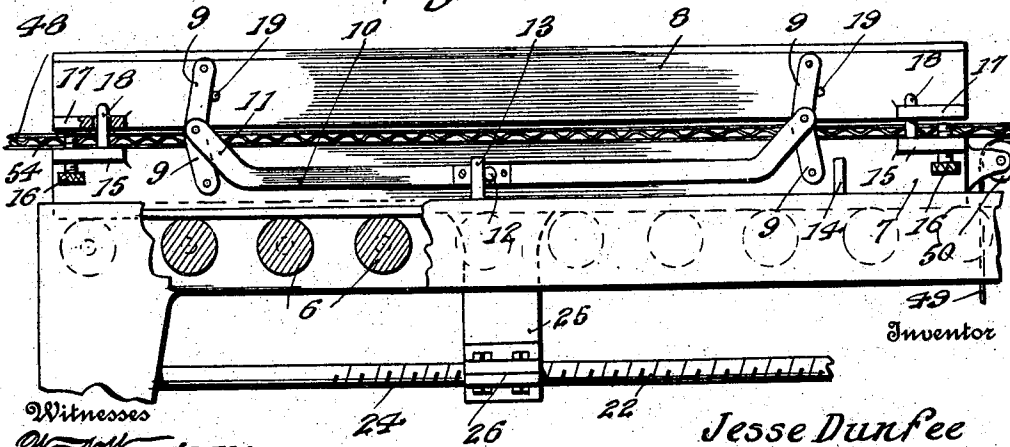

Fig. 5.



Witnesses  
 W. A. Woodson  
 Juana M. Fallin

Jesse Dunfee

Inventor  
 384  
 H. A. M. L. S. Attorneys.

# UNITED STATES PATENT OFFICE.

JESSE DUNFEE, OF COSHOCTON, OHIO, ASSIGNOR OF ONE-HALF TO SUSAN RINNER, OF COSHOCTON, OHIO.

DOUBLE-FACER FOR CORRUGATED-PAPER MACHINES.

982,176.

Specification of Letters Patent.

Patented Jan. 17, 1911.

Application filed October 7, 1910. Serial No. 585,868.

*To all whom it may concern:*

Be it known that I, JESSE DUNFEE, a citizen of the United States, residing at Coshocton, in the county of Coshocton and State of Ohio, have invented certain new and useful Improvements in Double-Facers for Corrugated-Paper Machines, of which the following is a specification.

My invention relates to facing corrugated paper, that is, for applying oppositely disposed sheets of plain paper to a middle corrugated web, pressing said sheets into contact with the web and simultaneously drying the same, thus forming a cellular sheet of pasteboard having outer plain faces.

In particular, my invention relates to mechanism for pressing the sheets of plain paper into contact with the corrugated sheet and subjecting to heat so as to cause the outer sheets to adhere to the corrugated web, while simultaneously feeding forward the combined cellular sheet so formed.

The primary object of the invention is the provision of improved means for simultaneously heating, pressing and feeding the combined sheets whereby the sheets are pressed between reciprocating platens or chests having a relatively large area and fed forward with the forward movement of the platen, thereby subjecting the board to a very uniform pressure over a large surface and doing away with the constant variations in pressure incident to pressing rollers.

A still further object is to provide means whereby these platens may be spaced from each other such distance to permit the platens on a return movement, when they slide over the paper, to be adjusted so as to entirely relieve the paper of pressure, or to be adjusted so that an ironing action may be given to the paper, these adjustable stops whereby this result is attained also providing means for preventing the platens moving into too close proximity to each other and thus crushing the paper between them.

Further objects of the invention will appear in the course of the following description.

My invention is shown in the accompanying drawings wherein:

Figure 1 is a side elevation of a facing machine constructed in accordance with my invention. Fig. 2 is a plan view thereof, partly broken away and partly in section. Fig. 3 is an enlarged fragmentary perspec-

tive view of the platens removed from the supporting bed. Fig. 4 is a cross section on the line 4—4 of Fig. 1. Fig. 5 is an enlarged side elevation, partly broken away of a portion of the supporting bed and a pair of platens thereon.

Referring to these drawings 2 designates a supporting bed constructed in any suitable manner and provided with the legs 3 and with the side plates or bars 4 which extend longitudinally the whole length of the bed.

Extending parallel to the bars 4 and spaced therefrom are the longitudinal bars or plates 5 which are attached to the ends of the bed or frame 2, and supported between the bars 4 and the bars 5 are the two sets of antifriction rollers 6. It will be seen that the longitudinal bars 5—5 are spaced apart from each other a suitable distance so as to provide a longitudinally extending opening for a depending bracket on the lower platen of each pair of platens.

Supported on the rollers 6 are a plurality of pairs of pressing platens, each pair of platens comprising a lower platen and an upper platen. As shown in Figs. 3, 4 and 5, the lower platen 7 rests upon the roller 6 and is movable longitudinally thereon. The upper platen is superposed upon the lower platen 7 and is connected to the lower platen by means of toggle links 9. A pair of these links are located near each end of the platens 7 and 8 and on each side of the platens. The toggle links on each side are pivotally connected to each other and to a longitudinally extending connecting rod 10, the ends of which are upwardly and outwardly bent or inclined as at 11. The middle of each rod 10 is provided with the outstanding lug 12, which in the movement of the platens is adapted to engage with upwardly projecting studs or lugs 13 and 14 extending upwardly from the upper edges of the bars 4 of the frame or bed. Thus at the termination of a movement by the platens in one direction the lug 12 will contact with the stud 13, while at the termination of the movement of the platens in the other direction the lug 12 will contact with the stud 14, thereby shifting the connecting rod 10 in one direction or the other and thereby straightening out or folding the links 9, thus raising or lowering the upper platen 8.

Each of the lower platens 7 is provided at

its ends with the outstanding ears 15 through which pass the set screws 16, while each of the upper platens is also provided at its ends with light ears 17 with which the screws 16 are adapted to engage. These screws form adjustable stops limiting the relative movement of the platens toward each other. In order to hold the upper and lower platens in alinement with each other, the ears 15 and 17 are provided, one with a pin 18 projecting upwardly from the ear and the other with a perforation through which the pin is adapted to pass. When the platens are in operative position with relation to each other, the pin 18 is always in engagement with the perforation in the opposed ear, the amount of movement of the platens toward and away from each other being relatively slight and only sufficient to permit the upper platen to raise above the upper surface of the pasteboard sheet passing between the platens. Stops 19 project from the side of the upper platen, designed to limit the movement of the toggle links 9 so that the links cannot be moved into a position of alinement which would tend to prevent the easy operation of the platens.

Each of the platens comprises a rectangular casing of metal, and located within this casing are resistance coils 20 or steam pipe coils, or any other suitable means of heating the platen. The platen is preferably covered upon its upper face by a plate 21. The detailed construction of these platens does not, however, form any particular part of my present invention as these platens may be formed in any suitable manner and heated by gas, electricity or steam as desired, the heating of these platens being well understood in the art.

As shown in Fig. 1, two pairs of platens 7 and 8 are used, but I do not wish to limit myself to any number of these platens as a greater or less number might be used.

The platens are intended to have a reciprocating motion in opposite directions so that as one pair of platens moves from the rear toward the front of the machine, the other of the platens will simultaneously be moving from the front toward the rear of the machine. The forward moving platen grips the paper as it moves forward and feeds the paper forward, while the rearwardly moving platen at this time is open and moves rearward without contacting with the paper, or only contacting with it slightly. Thus a continuous feed will be given to the paper, while the pairs of platens will act alternately. While I may use any desired mechanism for the purpose of giving this reciprocating movement to the platens and reciprocating the platens in opposite directions, I have shown for this purpose a longitudinally extending shaft 22 which is provided along its length with oppositely pitched screw threads

23 and 24. The lower platen 7 of each pair of platens is provided with a downwardly extending bracket 25 having thereon a sectional nut 26 which engages with the screw threads. It will be seen that with this construction the shaft 22 must be revolved alternately in opposite directions, and that when this shaft is revolved in one direction the screw threads 23 and 24 will cause one of the pairs of platens to move forward while the other pair will move backward, and that when the shaft is reversed in the direction of its rotation the movement of the platens will also be reversed.

In order to provide for reversing the direction of rotation of the shaft 22 at suitable intervals, I have provided the mechanism shown in Fig. 2. The shaft 22 is provided at its extremity with the bevel gear wheel 27 which engages with a bevel gear wheel 28 on a transversely extending shaft 29. This shaft carries upon it the loose pulleys 30 and 31 and the driving pulley 32 which is fast on the shaft. The shaft is supported, of course, in suitable bearings 33 and 34. Over one of the pulleys, as for instance the pulley 30, passes a crossed belt 35 driven from any suitable pulley, not shown, and over the pulley wheel 31 passes the straight belt 36. Connected to these belts are the shipper arms 37 of any usual construction and designed to shift transversely so as to carry either the crossed belt 35 into engagement with the pulley 32, or carry the straight belt 36 into such engagement. As illustrated in Fig. 2 the straight belt 36 is engaged with the pulley 32 while the crossed belt 35 is running on the loose pulley 30. The shipper arms 37 are connected to a transversely shiftable rod 38 mounted in suitable guides on the frame of the machine, having an upwardly projecting pin 39. Mounted in guides 40 on one of the side plates or bars 4 is a longitudinally movable rod 41. The extremity of this rod is downwardly bent as at 42, see Fig. 1, and laterally enlarged to form an angularly extending termination 43, this termination being provided with the angular cam slot 44 which engages with the pin 39. It will be obvious that as the bar 41 is shifted in one direction or the other that the cam slot 44 engaging with the pin 39 will reciprocate the shifter rod 38 in one direction or the other and thus shift the belts 35 and 36 on to or off from the pulley 32, and that the shaft 29 will thus be driven alternately in opposite directions.

As a means for shifting the rod 41 alternately in opposite directions, I provide the lower platen 7 of the pair of platens adjacent to the end of the machine with the outwardly projecting spaced studs 45 and 46 and provide the bar 41 with the upwardly projecting stud 47. It will be obvious now that when the pair of platens move rear-

ward the pin 45 will contact with the pin 47 when the platens have nearly reached the extremity of the stroke and that the pin will shift the pin 47 and the bar 41 toward the entrance end of the machine, and that upon a movement of the platens toward the exit end of the machine the pin 46 will eventually contact with the pin 47 and thus shift the bar 41 in a reverse direction, thus alternately changing the direction of rotation of the shaft 22.

For the purpose of supporting the web of corrugated cellular pasteboard 48 in the space between the two pairs of platens, I attach to the lower platens of one pair the canvas apron 49, which apron passes over a roller 50 mounted upon the end face of the lower platen 7 of the other pair of platens. The apron 49 extends over this roller 50 and is provided on its free end with a weight 51. This keeps the apron 49 always taut and takes up the slack in the apron when the pairs of platens move toward each other and permits the apron to increase in length when the pairs of platens move away from each other. The cellular cardboard web 48 is thus supported upon the apron 49 at all times.

While I of course do not wish to be limited to the use in connection with my machine of any special mechanism for feeding in and pasting the webs of corrugated and plain paper, I have illustrated in Fig. 1 the plain webs 52 as passing into the machine over rollers 53 supported in any suitable manner, the corrugated sheet 54 passing through corrugating rollers 55 and between paste-applying rollers 56.

The operation of my mechanism is as follows. Upon a rotation being given to the shaft in one direction, the rearmost pair of platens will be carried forward, the upper platen being lowered and pressing down upon the webs of the paper between the two platens, the amount of this pressure being regulated by the set screws 16. As the rearmost platens move forward they will of course carry the paper along with them and feed it forward over the apron 49. Simultaneously with the forward movement of the rearmost platens the forward platens will move rearward in the direction of the arrow in Fig. 1, the toggle links being turned nearly into alinement with each other and hence the upper platen being raised a sufficient distance to permit the platen to slip over the web 48. As the pairs of platens move toward each other the apron 49 will roll down over the roller 50 to accommodate the increasing distance between the platens. When the rearmost pair of platens has reached the extremity of its forward movement, the stud 12 on each connecting rod 10 will contact with the lug 14 and the slight further forward movement which the plat-

ens have will of course cause the lug 14 to exert a pull upon the rod 10 which will straighten the toggle links and lift the upper platen 8 of the pair off from the web 48. When this has been accomplished the direction of rotation of the shaft 22 will be changed and the rearmost platen will move backward until such time as the stud 12 on the connection 10 engages with the lug 13, whereupon the rod 10 will be pulled to fold the links into the position shown on the right hand side of Fig. 1, thus bringing the upper down again upon the paper. Exactly the same movement will occur with the forward pair of platens, the uppermost platen of which will be raised or lowered as the lug 12 on each of the connecting rods 10 engages with the studs 13 and 14. It will thus be seen that while the platens reciprocate in opposite directions to each other, the paper is given a continuous feed forward, and that the paper is subjected to pressure over its entire surface, the degree of this pressure being regulated by the screws 16. It will also be seen that by altering the position of the stops 19 so as to limit the movement of the links 9 the platens may be caused to open to an extent barely sufficient to permit the platens to move backward over the paper, and that therefore the upper platen will exert an ironing action upon the paper if desired. Under ordinary circumstances, however, the pins will be so set that the links can open to their full extent, thus entirely raising the uppermost platen out of contact with the web or paper 48, relieving all pressure upon the paper so that the platens may move rearward with very little frictional contact with the paper. It will also be noted that my construction provides that the web 48 shall be subjected to the pressure of the platens during the whole movement of each pair of platens forward, and that while the platens are moving forward the paper will be subjected to a uniform pressure throughout a relatively large area, which would not be the case were the paper merely passing between pressing rolls. Where pressing rolls are used there is liable to be slight variations in the rolls which prevents a uniform pressure on the paper being secured. It will also be seen that the pressure upon the web 48 is exerted over a large surface and hence does not tend to crush the corrugations of the web 54, as it would if the pressure was exerted through a comparatively narrow area, as where transversely extending rolls are used. Furthermore, by my construction there is a clamping action exerted on the paper, which is not secured by other devices known to me.

While I have shown what I believe to be the best details of my construction, I do not wish to be limited to said details as various changes might be made without departing

from the spirit of the invention. Thus I do not wish to be limited to the exact means shown for reciprocating the pairs of platens as it will be perfectly obvious that other  
 5 mechanism might be used for this purpose without changing in any way the action of the platens or their principal operation. Neither do I wish to be limited to the exact construction of the platens themselves as  
 10 these may be formed in any desired way and provided with any suitable means for heating the same. It will be obvious that my invention may be also applied to feeding, drying and surfacing other forms of paper and  
 15 pasteboard than the cellular corrugated board illustrated.

What I claim is:

1. In a machine for facing corrugated paper, opposed pressing platens, and means for separating said platens, moving them  
 20 rearward over the paper, closing the platens on the paper and moving the platens forward to feed the paper.

2. In a machine for facing corrugated paper, opposed pressing platens, means for separating said platens, moving them rearward over the paper, closing the platens on the paper and moving the platens forward,  
 25 and adjustable means for limiting the proximity of the platens in their closed position.

3. In a mechanism for facing corrugated paper, opposed pressing platens, means for heating the platens, and means for separating said platens, moving them rearward  
 30 over the paper, closing the platens on the paper, thereby gripping the latter, and moving the platens forward.

4. In a machine for facing corrugated paper, opposed pressing platens, toggle joints connecting said platens at each end thereof  
 40 and on each side, longitudinally extending links connecting the toggle joints to each other, means for moving the platens forward in contact with the paper, means engaging with the links for straightening the  
 45 toggle joints when the platens have reached their forward position, means for moving the platens rearward out of contact with the paper, and means for engaging the link and  
 50 folding said toggle joints to bring the platens again into gripping contact with the paper when the platens have reached the limit of their rearward movement.

5. In a machine for facing corrugated paper, a bed plate, a pair of upper and lower platens moving over said bed plate,  
 55 toggle joints located on each side of the platens and at each end thereof, a longitudinally extending link on each side of the platens connecting the toggle joints of that  
 60 side, each of said links having an outwardly projecting stud, spaced stops disposed on the bed plate with which said studs engage, the stops being located at opposite ends of  
 65 the path of travel of the platens, and means

for reciprocating said platens on the bed plate.

6. In a mechanism for facing corrugated paper, a bed plate, antifriction rollers mounted on the bed plate, a pair of upper  
 70 and lower platens supported on said rollers and movable thereover, means for reciprocating said pair of platens, and means for lifting the upper platen from the lower  
 75 platen as the platens move rearward on the bed plate, and for lowering the upper platen toward the lower platen as the platens move forward.

7. In a machine for facing corrugated paper, a plurality of pairs of pressing platens, each pair consisting of opposed upper  
 80 and lower platens, means for reciprocating said pairs of platens in opposite directions to each other, and means for causing the upper platen of each pair to lift as the pairs  
 85 of platens move rearward and for lowering the upper platen into gripping contact with the paper to be faced as the pairs of platens move forward.

8. In a machine for facing corrugated paper, a plurality of pairs of pressing  
 90 platens, each pair consisting of upper and lower platens, means for heating the platens of each pair of platens, means for reciprocating each pair of platens along the line  
 95 of the paper being faced, and means for causing the upper platen of each pair to lower as it moves forward, thus gripping the paper and to lift as it moves rearward, thus releasing the paper.

9. In a mechanism for facing corrugated paper, a bed, oppositely disposed antifriction rollers on the bed, said rollers being  
 100 spaced from each other to leave a longitudinally extending opening along the middle of the bed, a plurality of pairs of pressing platens supported on the rollers and extending  
 105 across the bed, each of said pairs comprising upper and lower platens, the lowermost platen of each pair having a downwardly projecting bracket extending through the longitudinal opening in the bed, toggle  
 110 joints connecting the upper platen of each pair to the lower platen, means engaging with the brackets of the lower platens to reciprocate the platens, means for raising  
 115 the upper platens from the lower as the platens move rearward, and means for lowering the upper platens toward the lower platens and into gripping contact with the  
 120 paper being corrugated upon the forward movement of the platens.

10. In a mechanism for facing corrugated paper, oppositely disposed coacting heating and pressing platens, and means for reciprocating said platens.

11. In a mechanism for facing corrugated paper, a bed, a plurality of pairs of pressing  
 130 platens mounted on the bed, each pair consisting of an upper and lower platen,

the lowermost platen of each pair having a  
downwardly extending bracket, oppositely  
disposed toggle joints located on each side  
of the platens and connecting the upper with  
5 the lower platen of each pair, a shaft mount-  
ed below the bed and having screw threaded  
engagement with the brackets of each lower  
platen, means for rotating the shaft alter-  
nately in opposite directions, the screw  
10 threads engaging with the bracket of one  
platen being reversely pitched to the screw  
threads engaging the next adjacent platen,

means for straightening the toggle joints of  
each platen as the platens reach the end of  
their forward movement, and means for 15  
folding the toggle joints of each platen as  
the platens reach the end of their rearward  
movement.

In testimony whereof, I affix my signature  
in presence of two witnesses.

JESSE DUNFEE. [L. s.]

Witnesses:

S. N. STAATS,  
R. K. MERRIAM.