



(19) **United States**
(12) **Patent Application Publication**
TOLKOWSKY et al.

(10) **Pub. No.: US 2014/0114308 A1**
(43) **Pub. Date: Apr. 24, 2014**

(54) **STABILIZED ENERGY-DELIVERY PROCEDURES**

Publication Classification

(71) Applicant: **SYNC-RX, LTD.**, Netanya (IL)
(72) Inventors: **David TOLKOWSKY**, Tel Aviv (IL);
Gavriel IDDAN, Haifa (IL)

(51) **Int. Cl.**
A61B 18/14 (2006.01)
(52) **U.S. Cl.**
CPC *A61B 18/1492* (2013.01)
USPC **606/41**

(73) Assignee: **SYNC-RX, LTD.**, Netanya (IL)

(57) **ABSTRACT**

(21) Appl. No.: **14/143,209**
(22) Filed: **Dec. 30, 2013**

Related U.S. Application Data

(63) Continuation of application No. 12/075,244, filed on Mar. 10, 2008.
(60) Provisional application No. 60/906,091, filed on Mar. 8, 2007, provisional application No. 60/924,609, filed on May 22, 2007, provisional application No. 60/929,165, filed on Jun. 15, 2007, provisional application No. 60/935,914, filed on Sep. 6, 2007, provisional application No. 60/996,746, filed on Dec. 4, 2007.

Apparatus and methods are described for use with a portion of a subject's body that moves as a result of cyclic activity, including sensing a phase of the cyclic activity. In a first cycle of the activity, in response to sensing that the activity is at a given phase, a therapeutic tool is actuated to apply a treatment to the portion by applying energy to the portion. Following the given phase in the first cycle and prior to an occurrence of the given phase in a subsequent cycle, the tool is inhibited from applying energy to the portion. In a second cycle of the activity, subsequent to the inhibiting of the application of energy to the portion, and in response to sensing that the second cycle is at the given phase, the tool is actuated to apply energy to the portion. Other applications are also described.

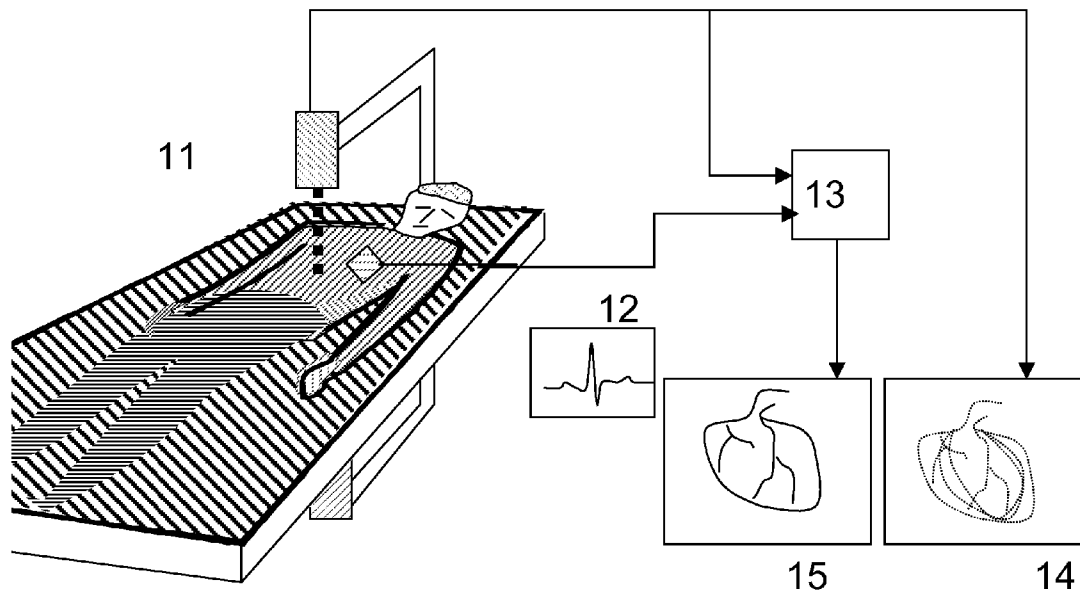

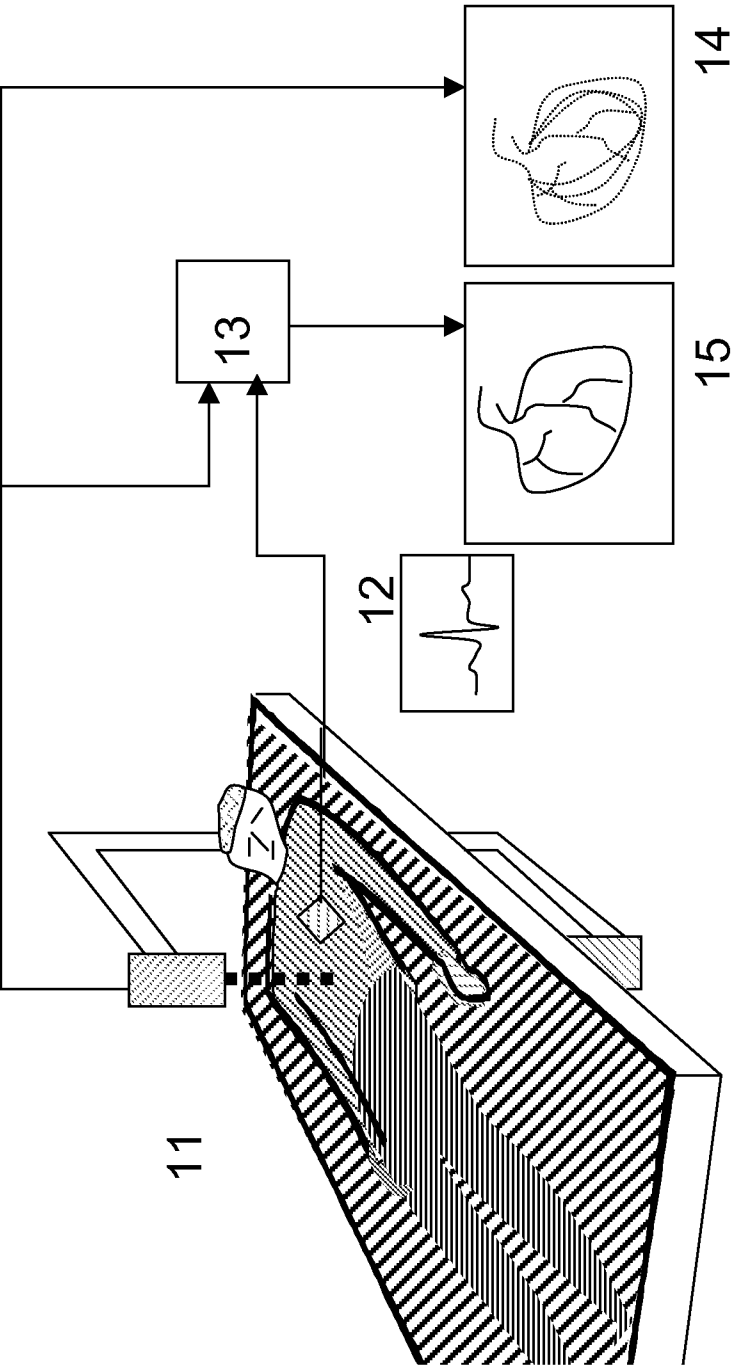

FIG. 1

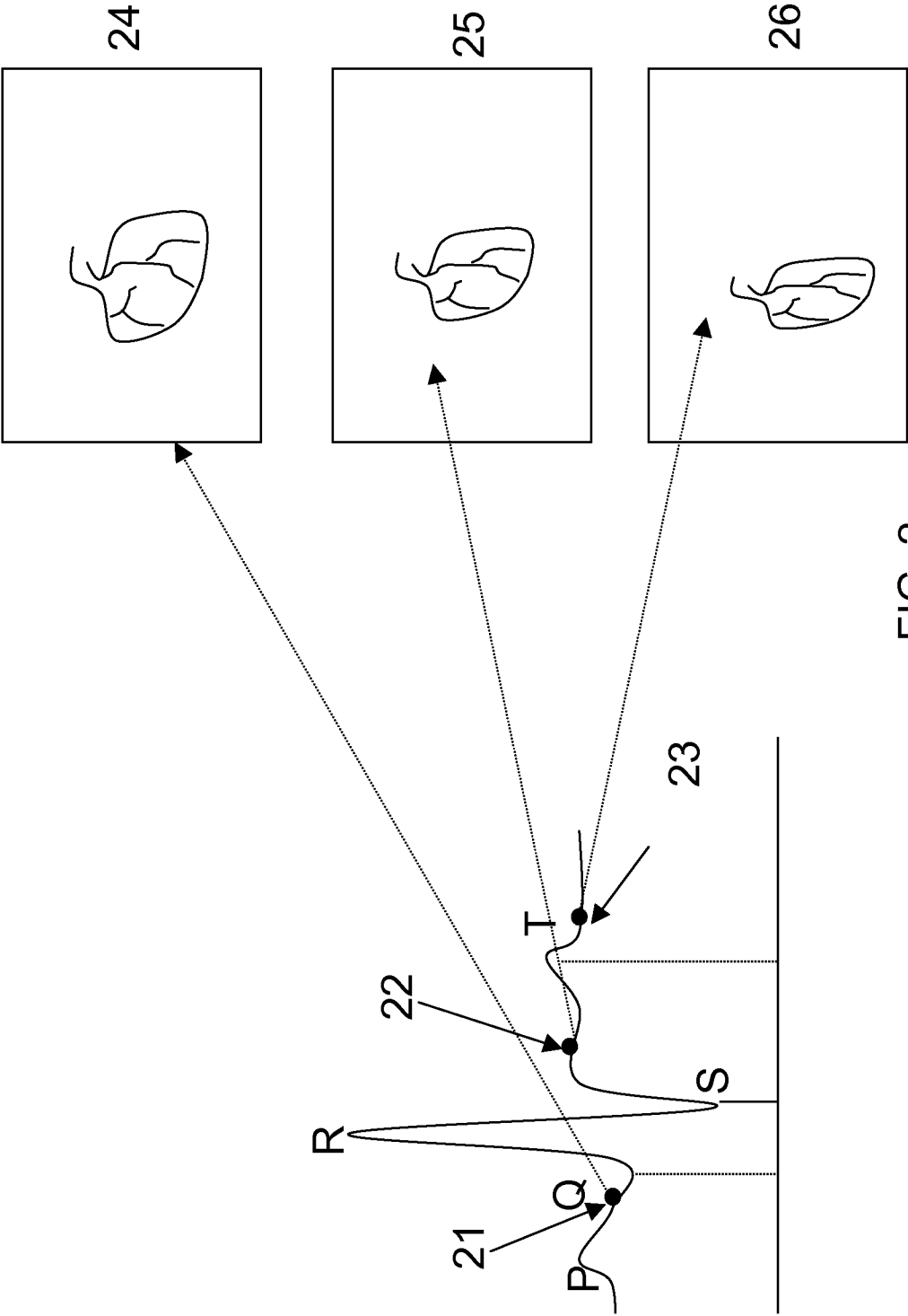

FIG. 2

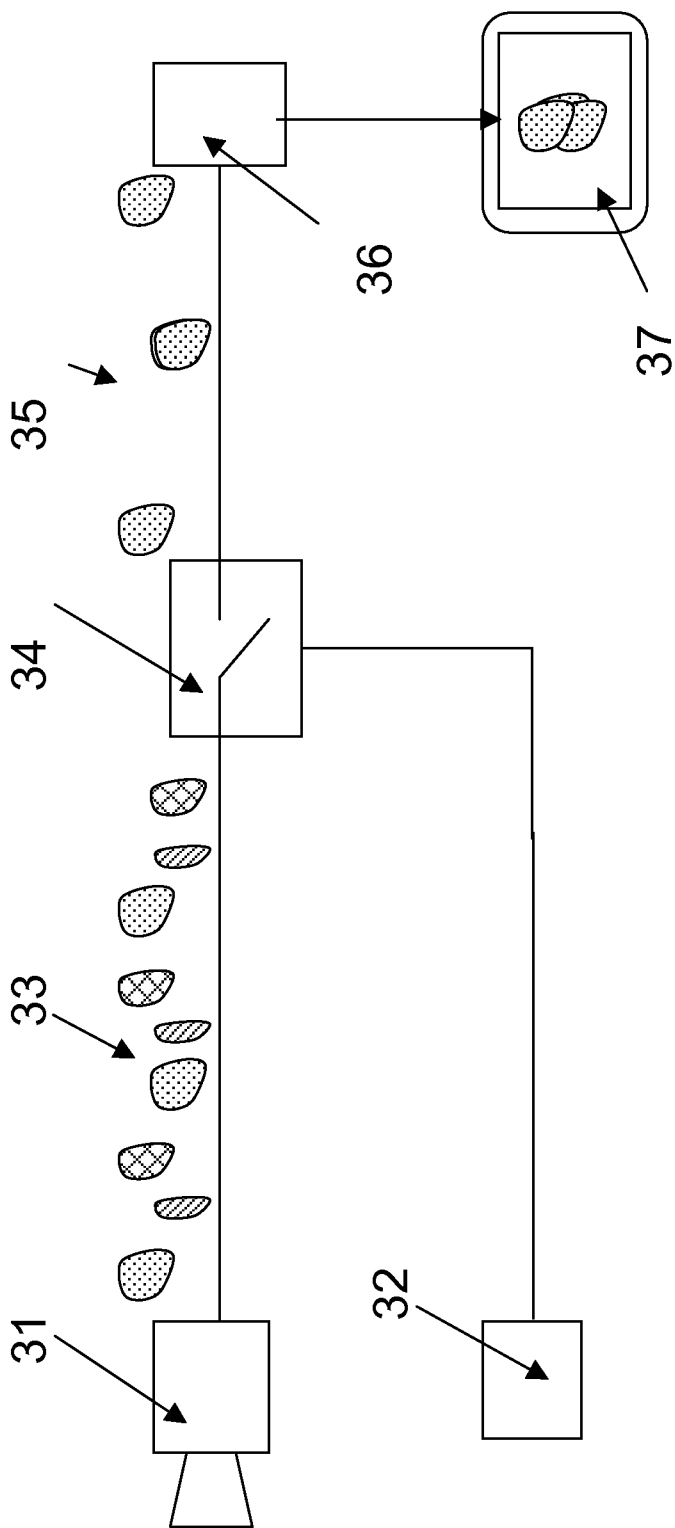

FIG. 3

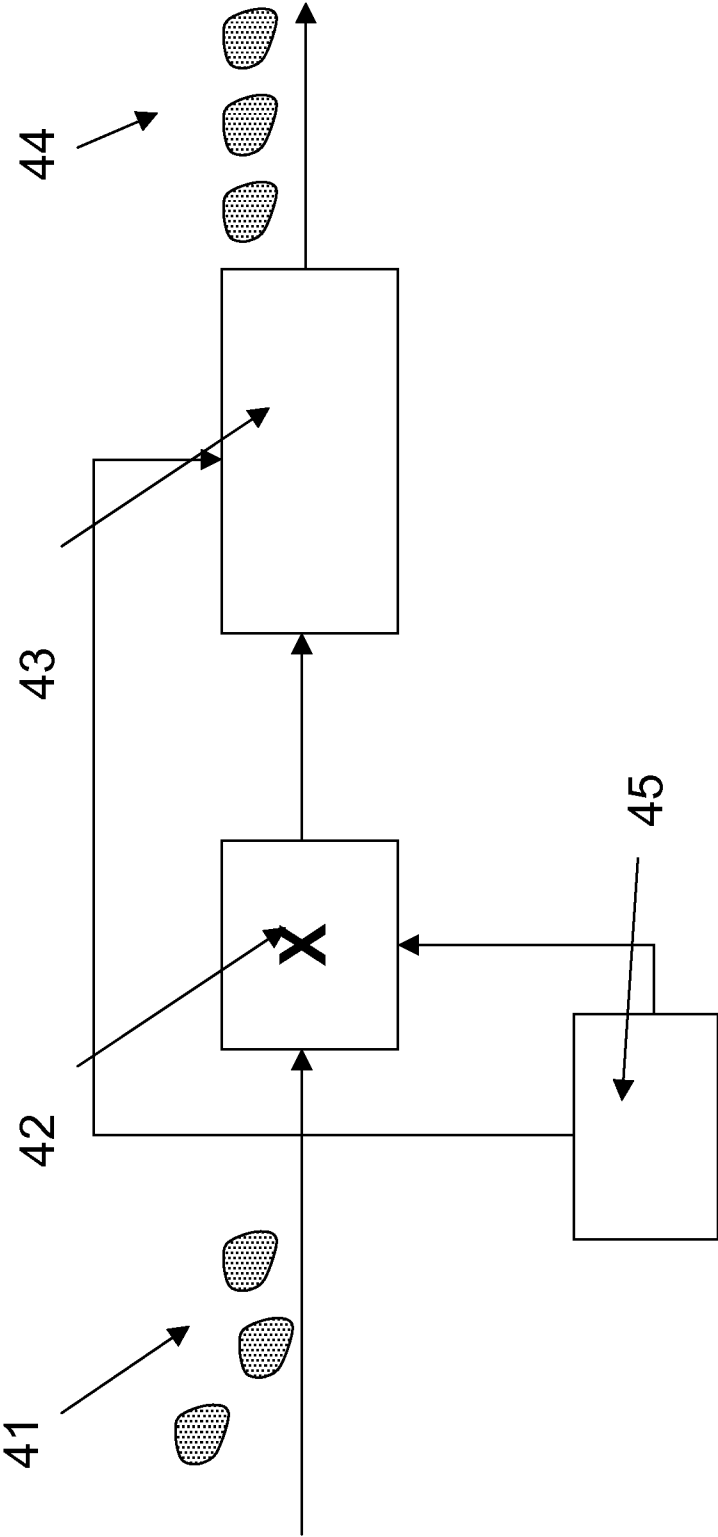

FIG. 4

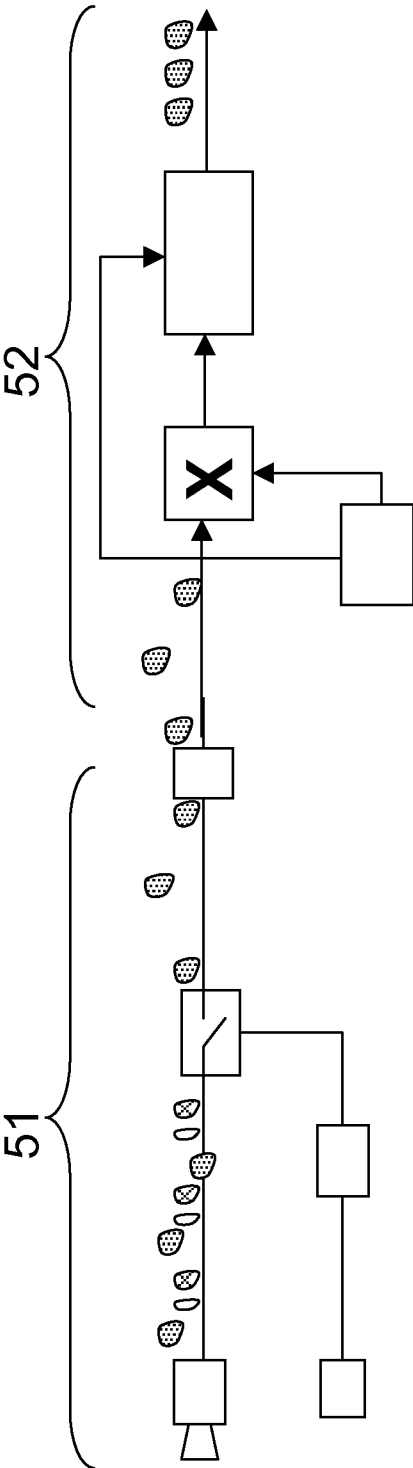

FIG. 5

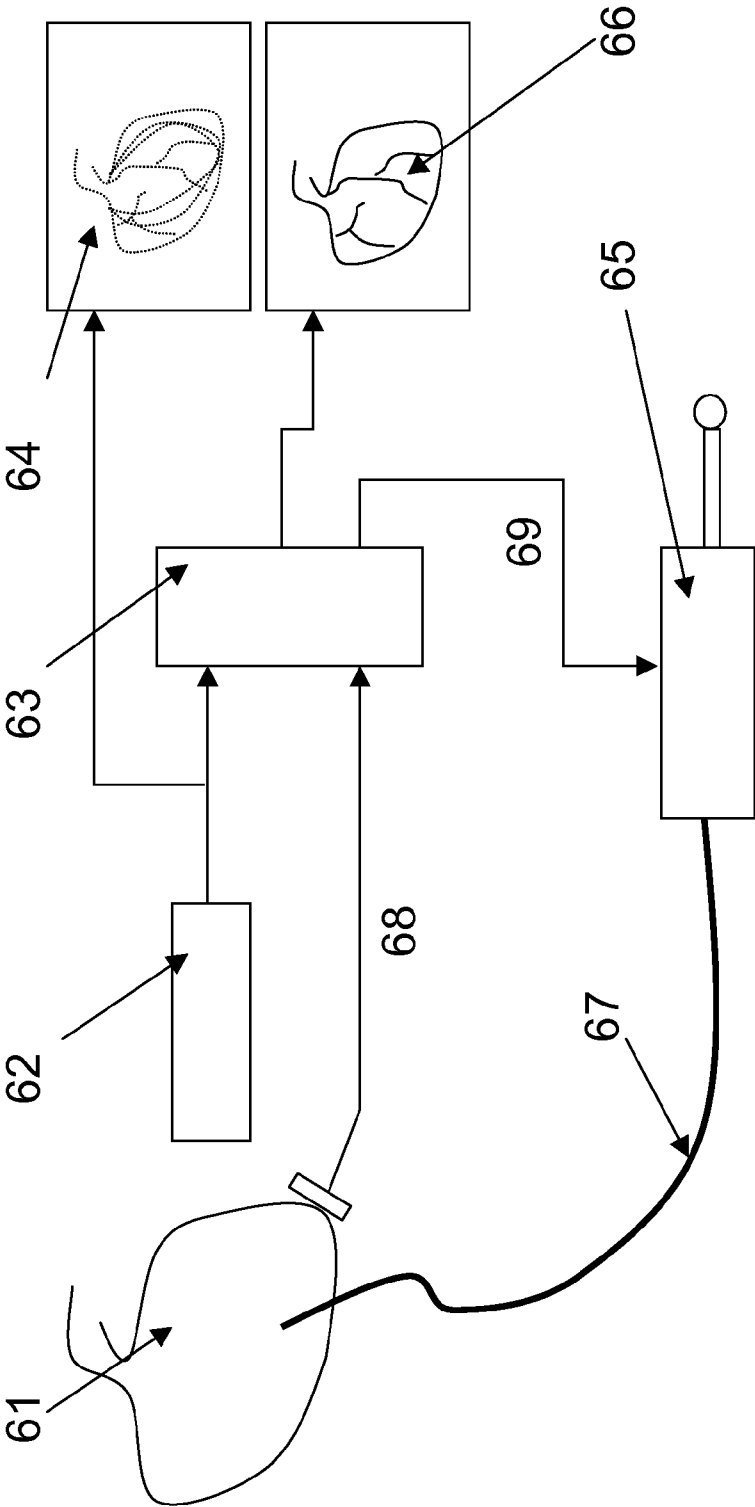

FIG. 6

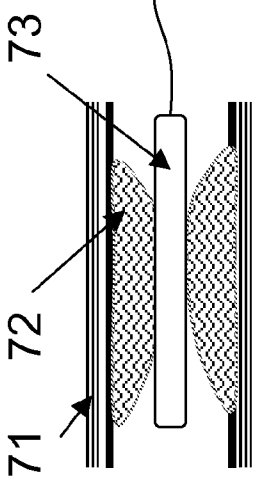
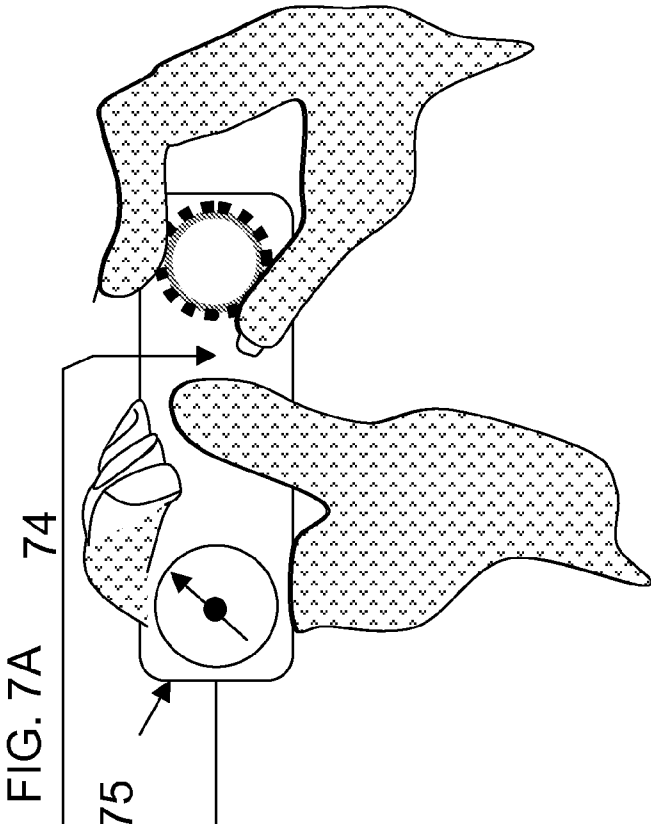

FIG. 7B

76

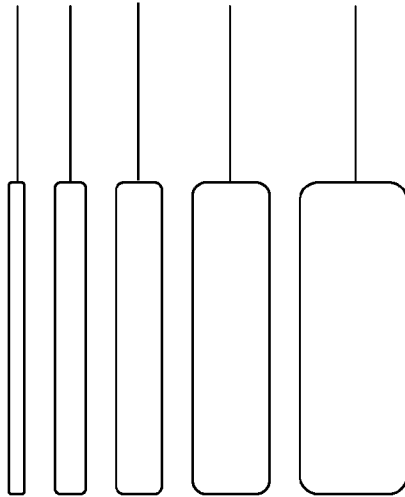
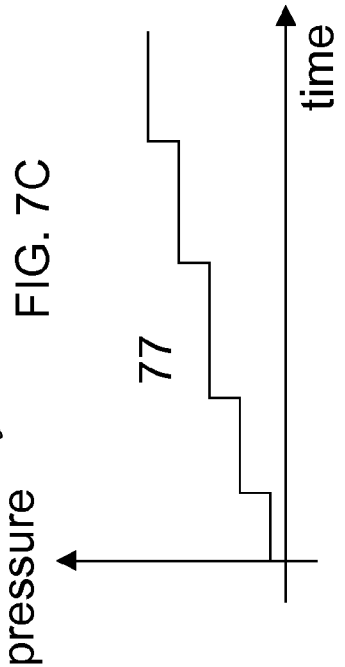

FIG. 7C



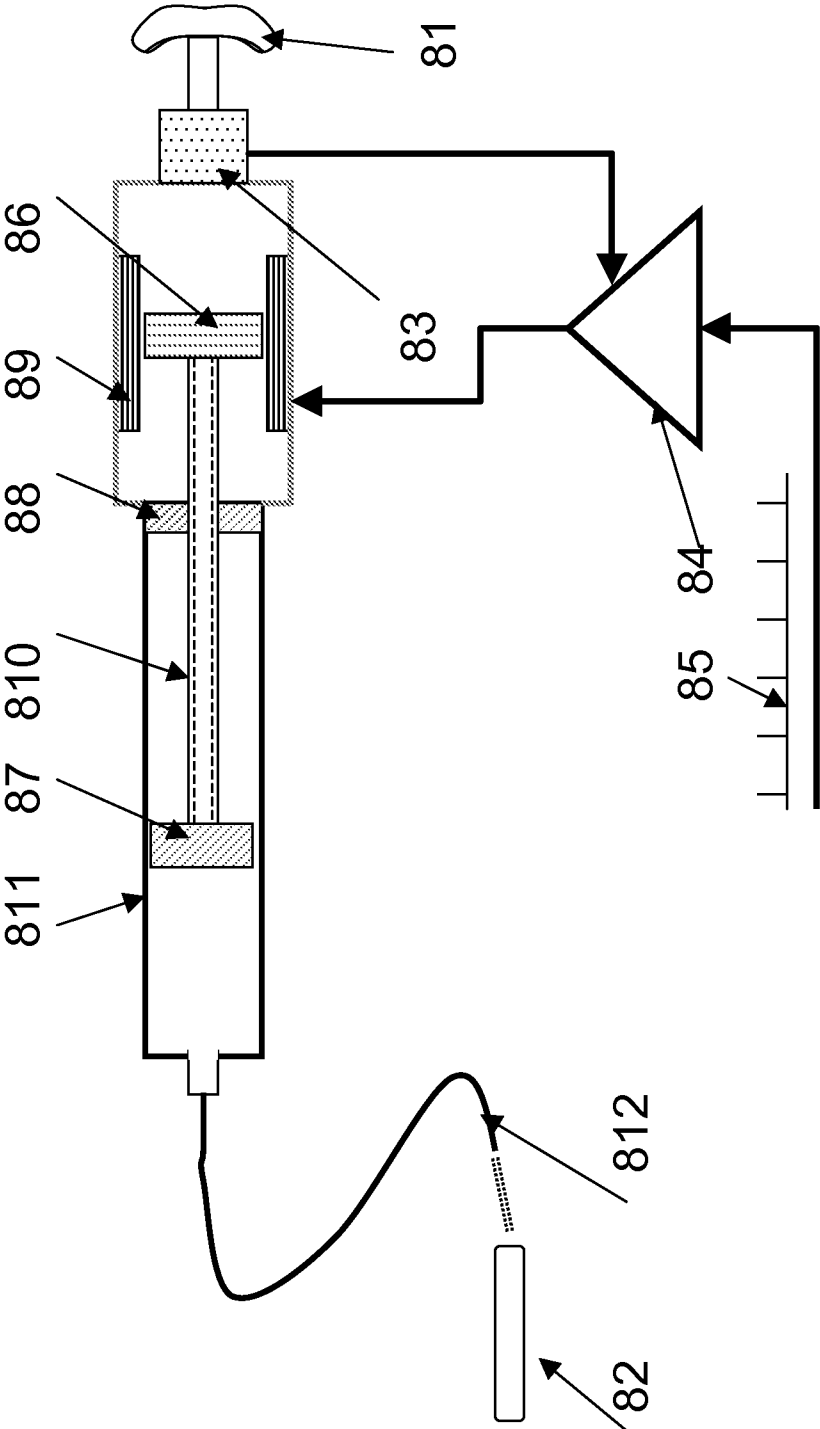

FIG.8

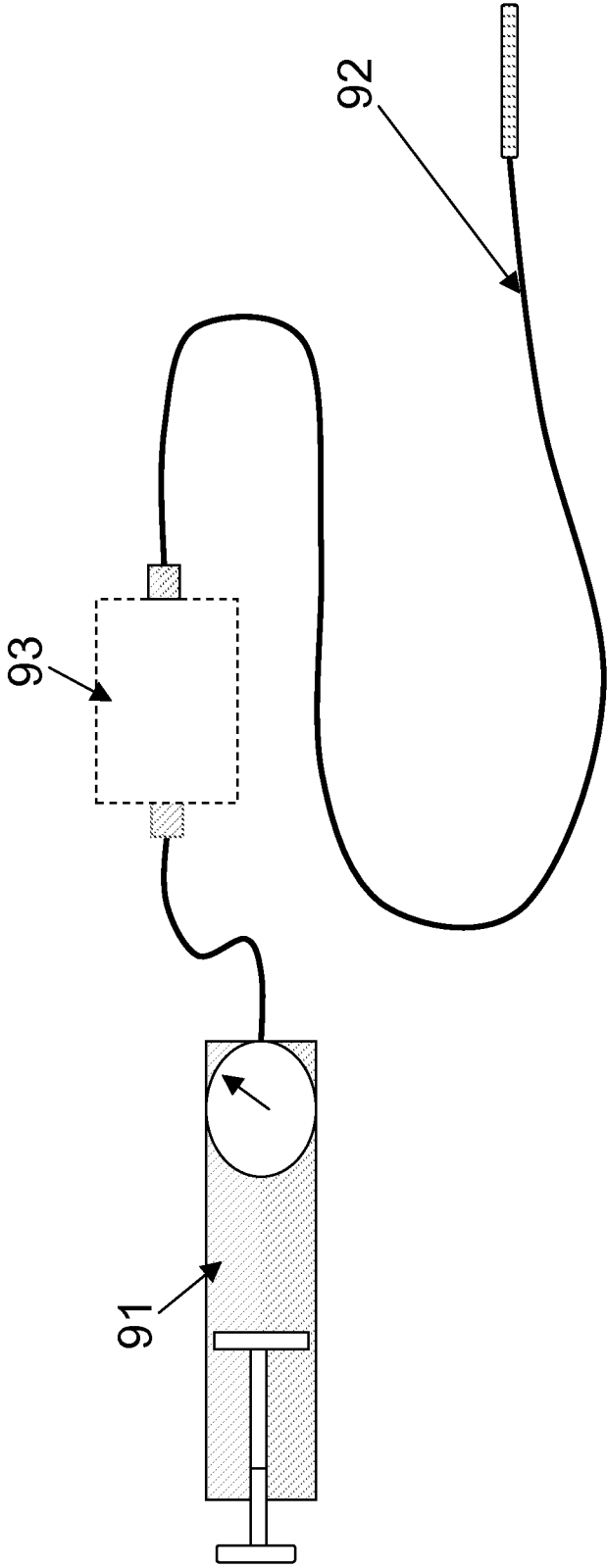

FIG. 9

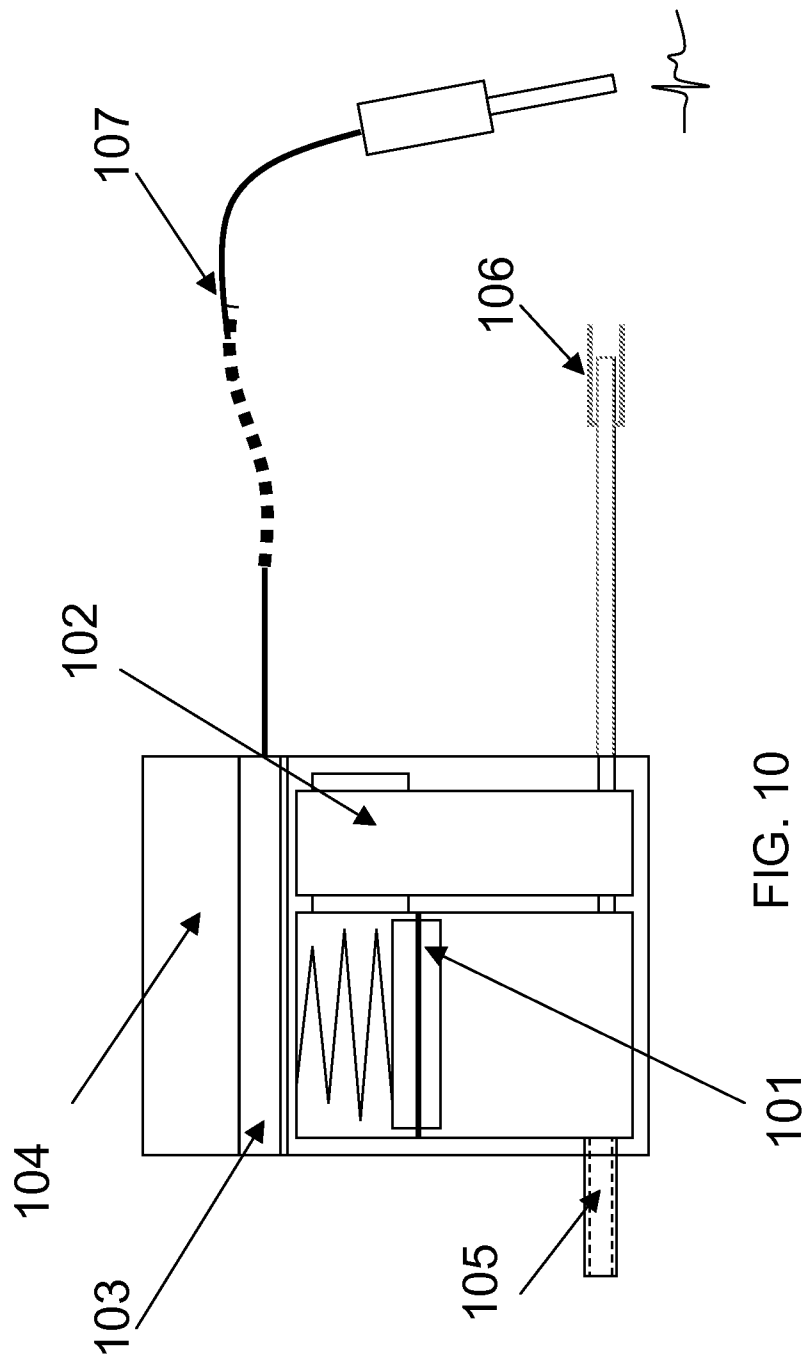

FIG. 10

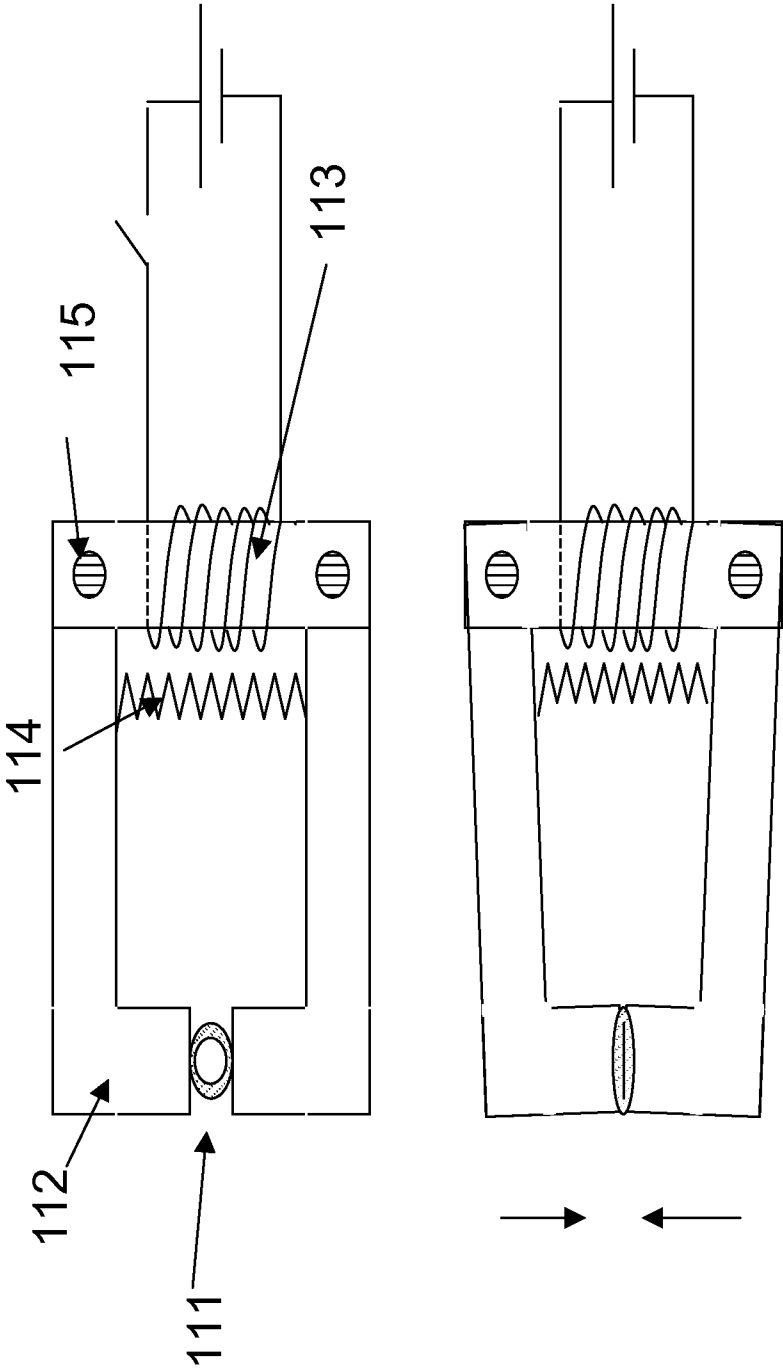

FIG. 11

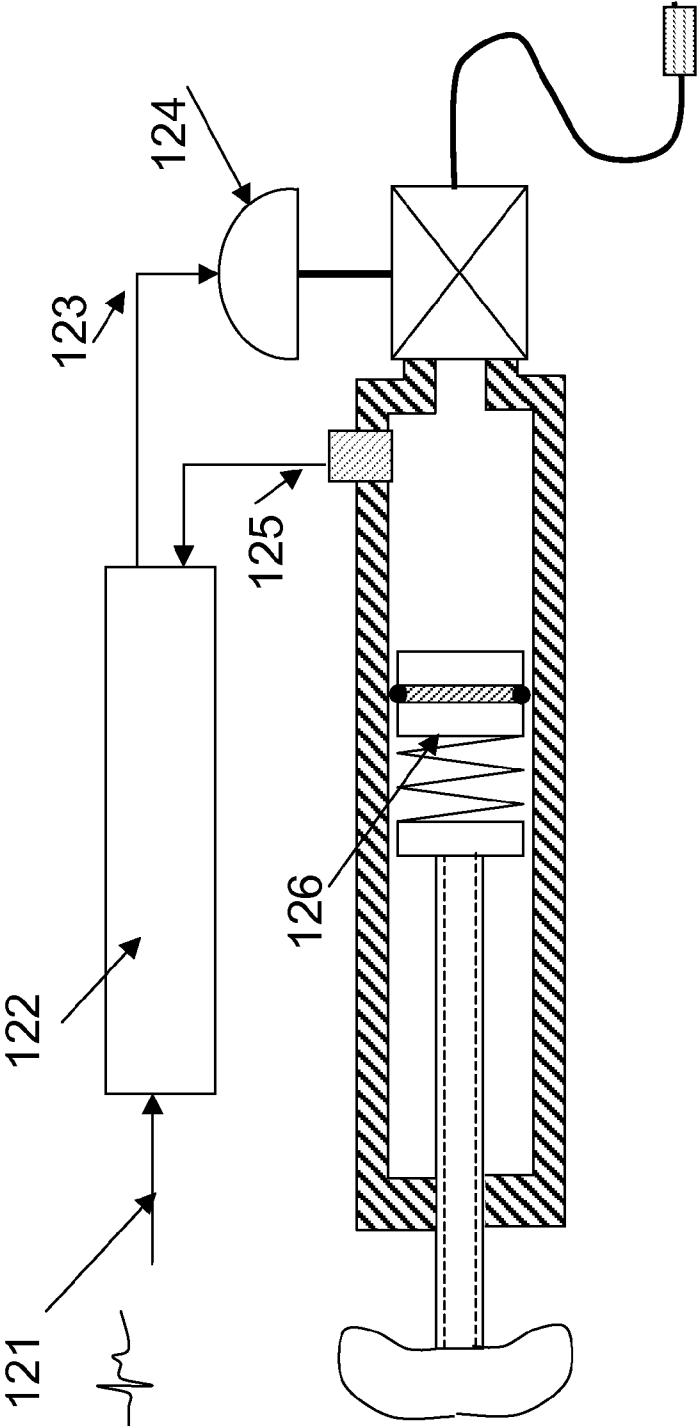

FIG. 12

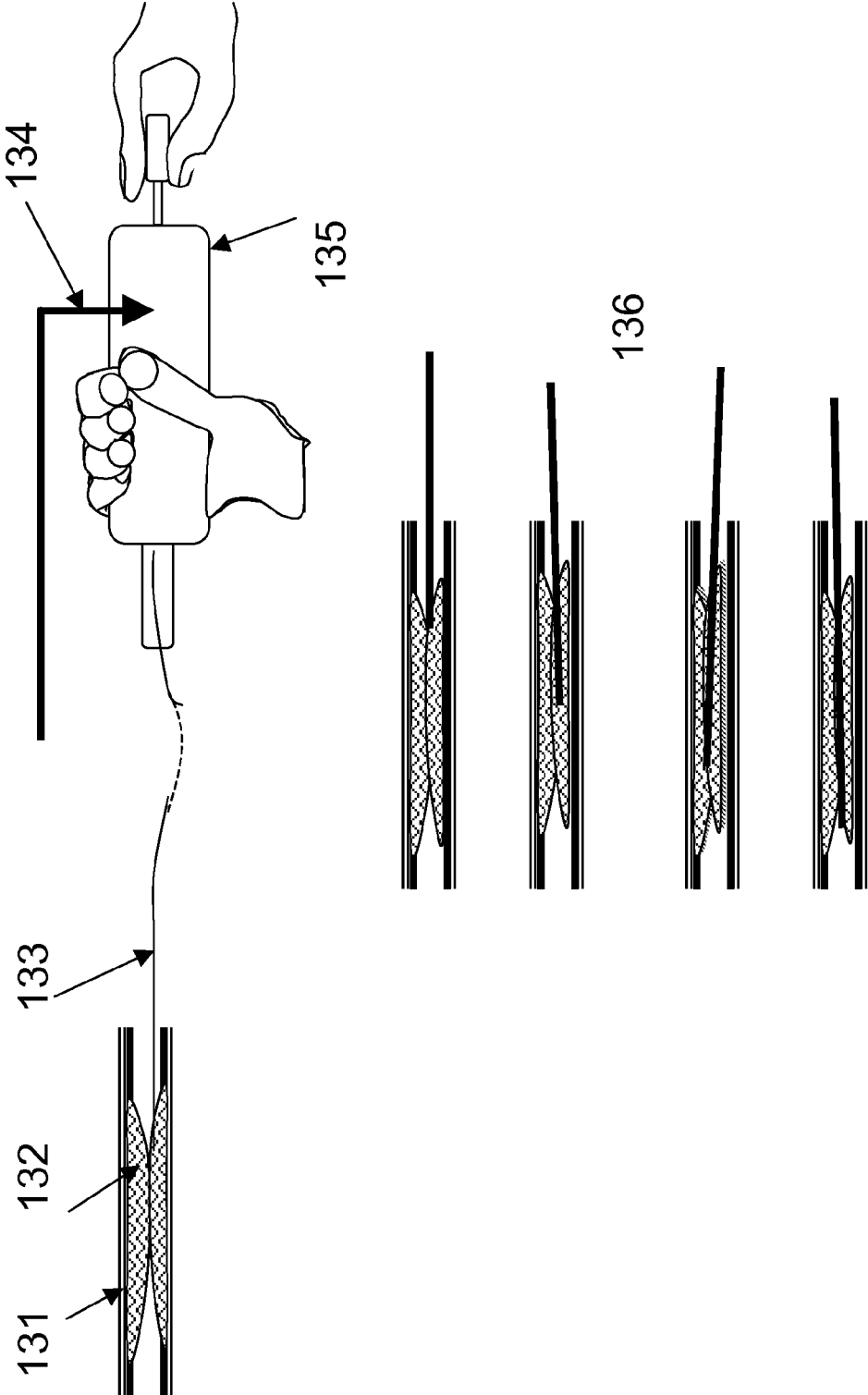

FIG. 13

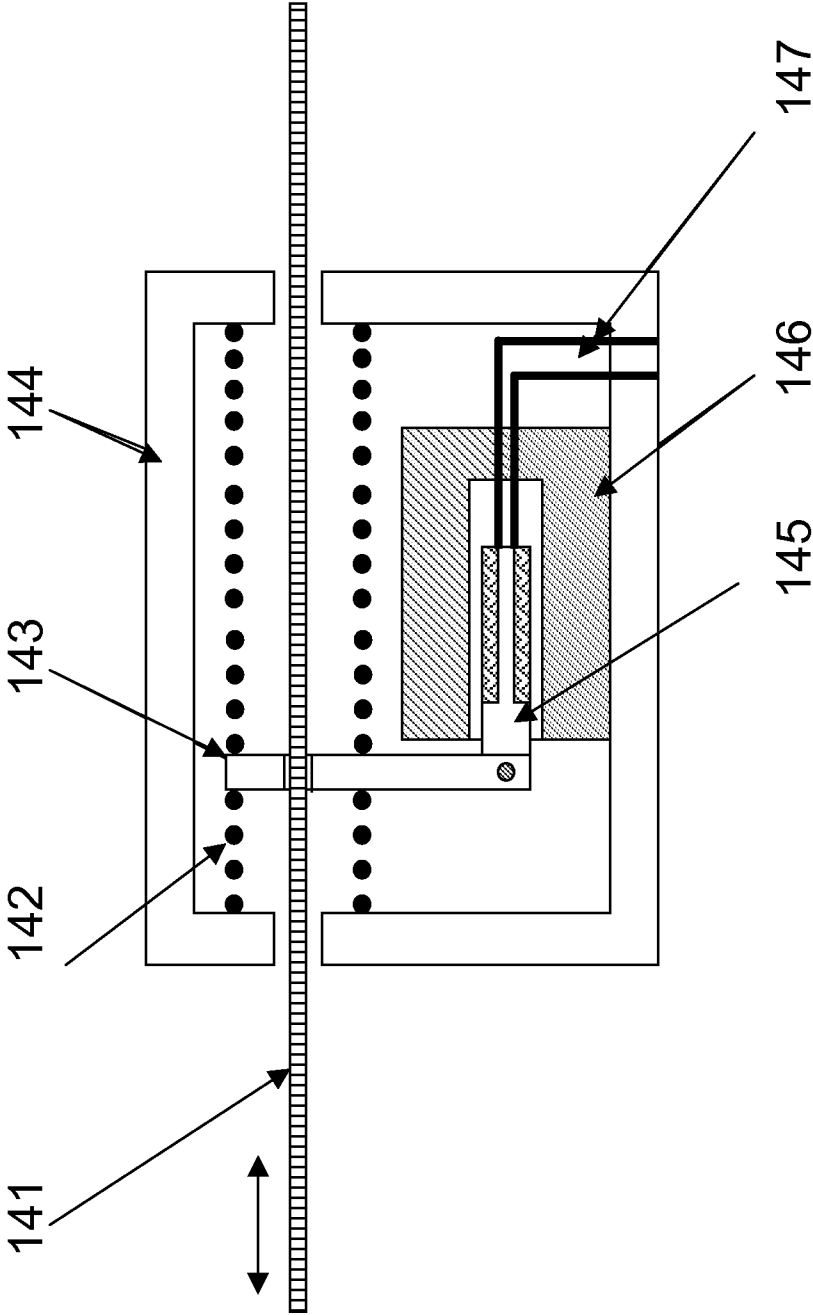
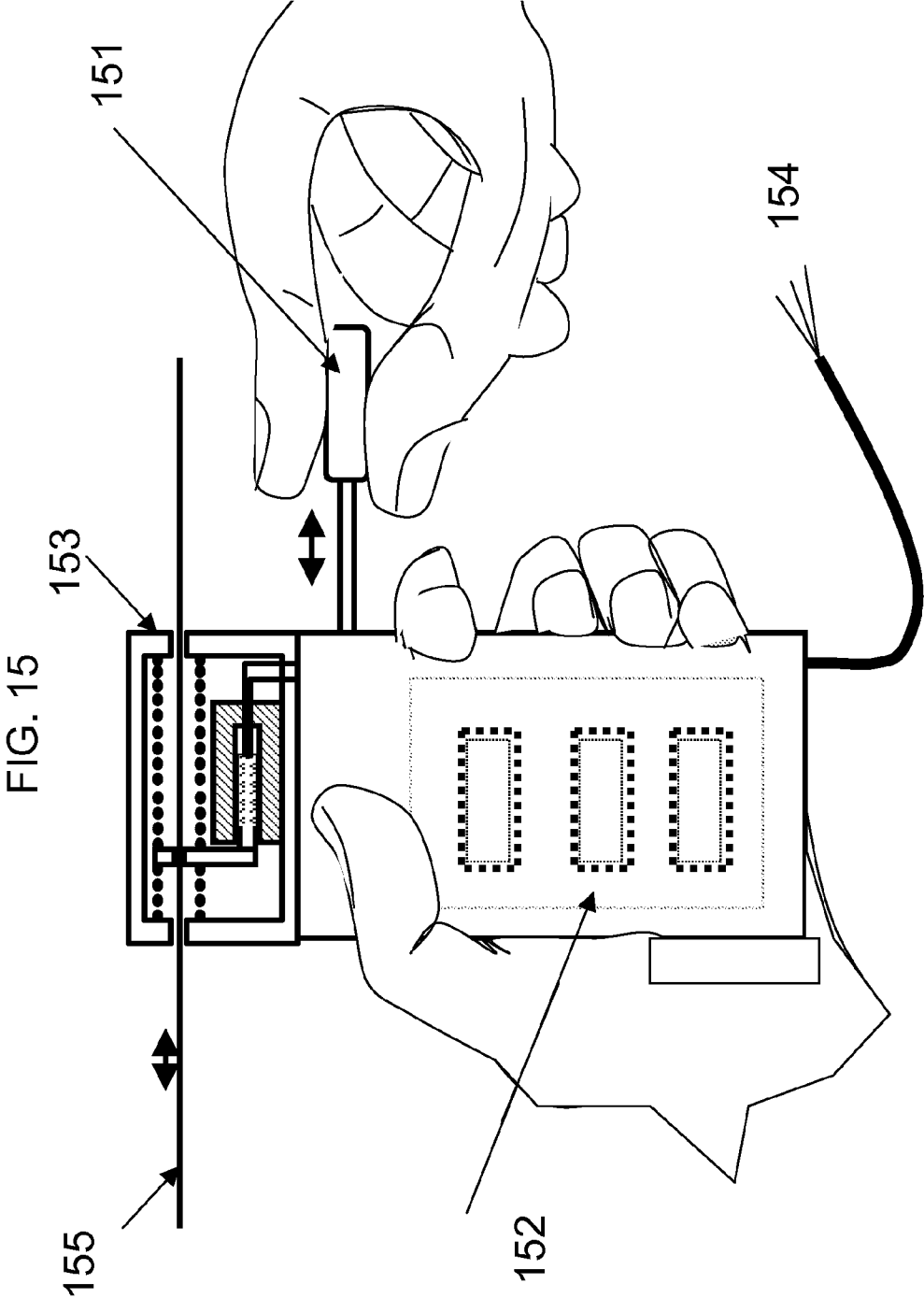

FIG. 14



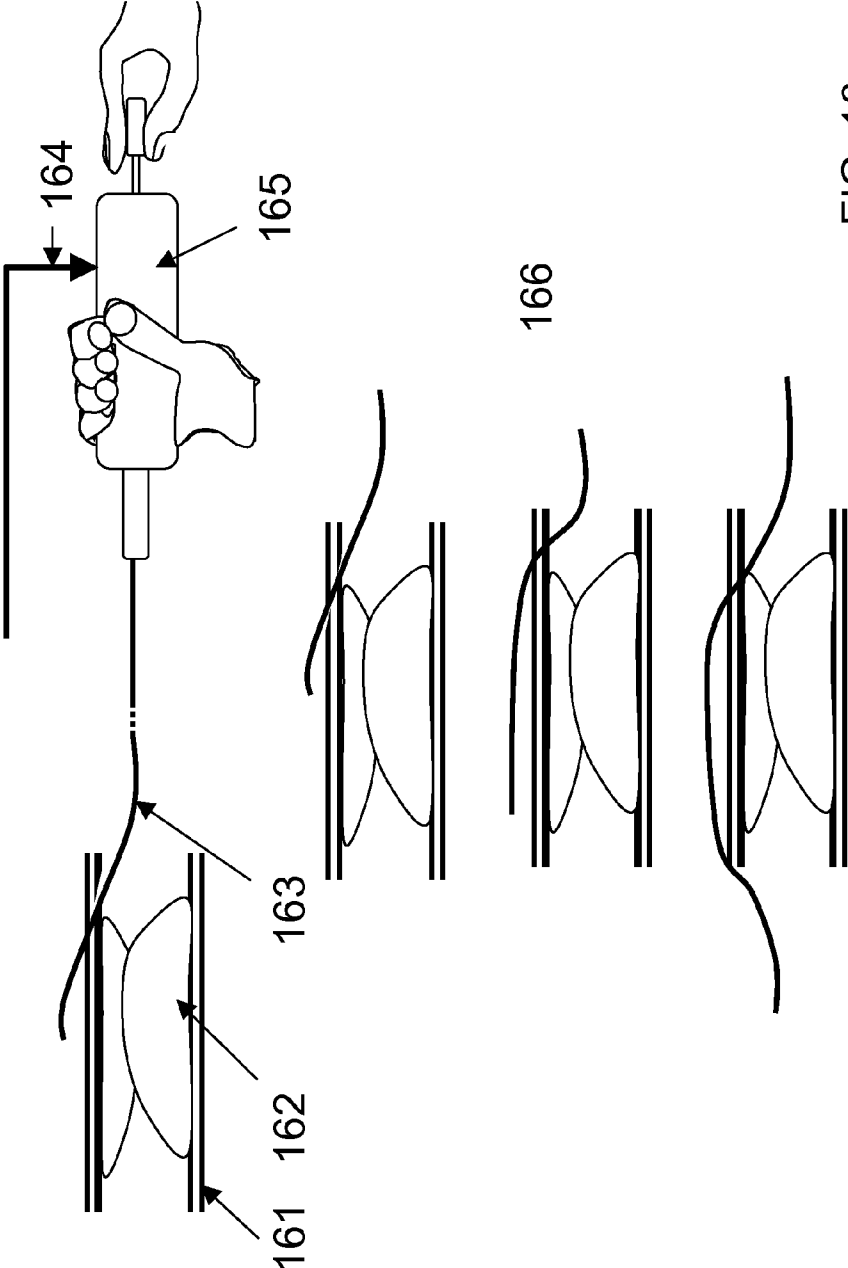

FIG. 16

STABILIZED ENERGY-DELIVERY PROCEDURES

CROSS-REFERENCES TO RELATED APPLICATIONS

[0001] The present patent application is a continuation of U.S. Ser. No. 12/075,244 to Tolokowsky et al. (published as US 2008/0221442), filed Mar. 10, 2008, which claims the benefit of U.S. Provisional Patent Application No. 60/906,091 filed on Mar. 8, 2007, 60/924,609 filed on May 22, 2007, 60/929,165 filed on Jun. 15, 2007, 60/935,914 filed on Sep. 6, 2007, and 60/996,746 filed on Dec. 4, 2007, all named "Apparatuses and methods for performing medical procedures on cyclically-moving body organs," all of which applications are incorporated herein by reference.

[0002] The present application is related to the following applications, which are incorporated herein by reference:

[0003] U.S. patent application Ser. No. 12/075,214, entitled "Tools for use with moving organs," to Iddan et al. (published as US 2008/0221439), filed Mar. 10, 2008.

[0004] U.S. patent application Ser. No. 12/075,252, entitled "Imaging and tools for use with moving organs," to Iddan et al. (published as US 2008/0221440), filed Mar. 10, 2008.

[0005] PCT Application PCT/IL2008/000316, entitled "Imaging and tools for use with moving organs," to Iddan et al. (published as WO 08/107,905), filed on Mar. 9, 2008.

FIELD OF THE INVENTION

[0006] The present invention generally relates to medical apparatus. Specifically, the present invention relates to stabilizing imaging of cyclically moving body portions.

BACKGROUND OF THE INVENTION

[0007] Continuous images of a cyclically-moving body organ are typically displayed in the course of many medical procedures such as procedures performed on the heart, the thorax, the respiratory tract, the eyes, or the cardiovascular system. Such images typically shift constantly and are also prone to blurring. Consequently, such images are typically difficult to observe, and are difficult to use in making clinical decisions over an extended period of time (such as the entire duration of the procedure).

[0008] Many procedures are performed with respect to moving body parts, for example the insertion of balloons and stents into moving blood vessels. A difficulty associated with such procedures is the targeted deployment and/or actuation of tools with respect to the moving body part.

[0009] U.S. Pat. No. 4,865,043 to Shimoni, which is incorporated herein by reference, describes a data selection method and system using a plurality of multi-dimensional windows wherein two parameters of ECG signals are tested for determining whether the imaging data received simultaneously with the ECG signal is to be accepted. The plurality of windows are described as providing a capability to gate and to sort imaging data based on the passage of associated ECG signals through each of the plurality of windows with different parameters. Thus images are described as being reconstructed for a population of abnormally short or long heart cycles from a common data pool.

[0010] U.S. Pat. No. 3,954,098 to Dick et al., which is incorporated herein by reference, describes a scan converter storage surface which is divided into image spaces corre-

sponding to different points in the heart cycle. Ultrasound echoes from heart structures are plotted in the image spaces by means of special x, y sweeps which are offset to the image spaces by timing circuitry.

[0011] U.S. Pat. No. 4,382,184 to Wernikoff, which is incorporated herein by reference, describes X-ray apparatus and methods for producing discrete images of a human organ in fluctuating motion, e.g., the heart and related vessels. Each image is derived at a selected time related to the cardiac cycle. The images are independently presented on respective discrete areas within a common image plane. A source of X-rays irradiates the organ. A physiological synchronizer produces timing signals within the cardiac cycle for controlling the periods of transmission of the X-ray beam through the organ during, for example, end diastole and end systole. An anti-scattering, masking frame has alternate parallel slits and bars at equal intervals exposing substantially half the area of presentation of an X-ray sensitive film in alternate, equally spaced area strips during, e.g., diastole. The frame is repositioned in response to a signal from the synchronizer for actuating it relative to the film, such that the bars then cover the sensitized areas of the film and expose substantially the remaining half of the film during systole. The image elements are interdigitally juxtaposed to present the diastolic and systolic images in an interlaced pattern. Relative displacements of the organ during a cardiac cycle may be determined from the juxtaposed image elements.

[0012] U.S. Pat. No. 4,016,871 to Schiff, which is incorporated herein by reference, describes a system which is capable of simultaneously displaying a plurality of waveforms on the face of a CRT which are representative of ECG, arterial pressures and operating states of the mechanical heart assistance devices, as well as a "timing bar" which sweeps across the CRT face in synchronism with the ECG trace, for example. Optical pickups are slidably mounted adjacent the CRT face across the path of the "timing bar" sweep for activating photodetectors which in turn initiate inflation and deflation of mechanical assistive devices at any desired point along the ECG or pressure trace. Any one of the pressure or ECG traces may be "frozen" on the display face to facilitate comparison between a trace of the condition of the heart prior to the use of heart assistance and a trace of the augmented condition. All traces may be freely moved to any location upon the display face so as to permit close positioning and even superimposition of two or more traces to still further facilitate visual comparisons. The timing bar may also be utilized to provide an electrical pacing assist for controlling patient heart rate as well as for extending the heart refractory period enabling the assistance devices to operate at reduced rates.

[0013] U.S. Pat. No. 3,871,360 to Van Horn et al., which is incorporated herein by reference, describes a system for timing biological imaging, measuring, or therapeutic apparatus in accordance with selected physiological states of a subject, featuring in various aspects generation of respiratory windows on the basis of processed electrical signals derived from prior respiration history, digital offset correction circuitry for the respiratory signals, and generation of cardiac timing signals on the basis of prior cardiac cycle history.

[0014] U.S. Pat. No. 4,031,884 to Henzel, which is incorporated herein by reference, describes apparatus for correlating the respiratory and cardiac cycles includes a circuit for defining a chosen period in the progress of the respiratory cycle as the end of a regulatable delay beginning when the

ascending front of the inspiratorial pressure reaches a regulatable level as well as a circuit for defining a chosen period in the progress of the cardiac cycle as the end of a regulatable delay beginning when the differential dV/dt of the blood pressure reaches a regulatable level. An operator such as a terminal relay is activated upon the coincidence of these two periods in time after a regulatable delay and during a regulatable period.

[0015] U.S. Pat. No. 4,994,965 to Crawford et al., which is incorporated herein by reference, describes a method of reducing image artifacts in tomographic, projection imaging systems due to periodic motion of the object being imaged, and includes the acquisition of a signal indicative of the periodic motion. This signal is used to identify a quiescent period in the periodic motion so that the acquisition of projection data may be coordinated to be centered within the quiescent period.

[0016] U.S. Pat. No. 4,878,115 to Elion, which is incorporated herein by reference, describes a method in which a dynamic coronary roadmap of the coronary artery system is produced by recording and storing a visual image of the heart creating a mask sequence, recording and storing another dynamic visual image of the heart after injection of a contrast medium thereby creating a contrast sequence, matching the different durations of two sequences and subtracting the contrast sequence from the mask sequence producing a roadmap sequence. The roadmap sequence is then replayed and added to live fluoroscopic images of the beating heart. Replay of the roadmap sequence is triggered by receipt of an ECG R-wave. The result is described as a dynamically moving coronary roadmap image which moves in precise synchronization with the live incoming fluoroscopic image of the beating heart.

[0017] U.S. Pat. No. 4,709,385 to Pfeiler, which is incorporated herein by reference, describes an x-ray diagnostics installation for subtraction angiography, which has an image memory connected to an output of an x-ray image intensifier video chain which has a number of addresses for storing individual x-ray video signals obtained during a dynamic body cycle of a patient under observation. A differencing unit receives stored signals from the image memory as well as current video signals and subtracts those signals to form a superimposed image. Entry and readout of signals to and from the image memory is under the command of a control unit which is connected to the patient through, for example, an EKG circuit for identifying selected occurrences in the body cycle under observation. Entry and readout of data from the image memory is thereby controlled in synchronization with the selected occurrences in the cycle.

[0018] U.S. Pat. No. 4,270,143 to Morris, which is incorporated herein by reference, describes a cross-correlation video tracker and method for automatically tracking a relatively moving scene by storing elements from a frame of a video signal to establish a reference frame and comparing elements from a subsequent frame with the stored reference frame to derive signals indicating the direction and angular distance of scene relative movement. A cross-correlation difference signal is generated which represents the difference between a pair of cross-correlation signals dependent on the correlations of the subsequent frame elements and the stored reference elements at two predetermined opposite relative shifts. A circuit is responsive to this difference signal for generating an error signal indicative of the amount of shift required to center the stored reference frame with respect to the subsequent frame.

[0019] U.S. Pat. No. 4,758,223 to Rydell, which is incorporated herein by reference, describes a hand-operated device for inflating the expander on a balloon-type catheter and for perfusing fluids through the catheter and out its distal end.

[0020] U.S. Pat. No. 4,723,938 to Goodin et al., which is incorporated herein by reference, describes an inflation/deflation device for an angioplasty balloon catheter which permits quick inflation to an approximate working pressure followed by a fine but slower adjustment to a final desired pressure.

[0021] U.S. Pat. No. 6,937,696 to Mostafavi, which is incorporated herein by reference, describes a method and system for physiological gating. A method and system for detecting and estimating regular cycles of physiological activity or movements is also disclosed. Another disclosed embodiment is directed to predictive actuation of gating system components. Yet another disclosed embodiment is directed to physiological gating of radiation treatment based upon the phase of the physiological activity. Gating can be performed, either prospectively or retrospectively, to any type of procedure, including radiation therapy or imaging, or to other types of medical devices and procedures such as PET, MRI, SPECT, and CT scans.

[0022] U.S. Pat. No. 6,246,898 to Vesely et al., which is incorporated herein by reference, describes a method for carrying out a medical procedure using a 3-D tracking and imaging system. A surgical instrument, such as a catheter, probe, sensor, pacemaker lead, needle, or the like is inserted into a living being, and the position of the surgical instrument is tracked as it moves through a medium in a bodily structure. The location of the surgical instrument relative to its immediate surroundings is displayed to improve a physician's ability to precisely position the surgical instrument. The medical procedures including targeted drug delivery, sewing sutures, removal of an obstruction from the circulatory system, a biopsy, amniocentesis, brain surgery, measurement of cervical dilation, evaluation of knee stability, assessment of myocardial contractibility, eye surgery, prostate surgery, transmyocardial revascularization (TMR), robotic surgery, and evaluation of RF transmissions.

[0023] US Patent Application Publication 2006/0058647 to Strommer et al., which is incorporated herein by reference, describes a method for delivering a medical device coupled with a catheter, to a selected position within a lumen of the body of a patient, the method comprising the procedures of: registering a three-dimensional coordinate system with a two-dimensional coordinate system, the three-dimensional coordinate system being associated with a medical positioning system (MPS), the two-dimensional coordinate system being associated with a two-dimensional image of the lumen, the two-dimensional image being further associated with an organ timing signal of an organ of the patient; acquiring MPS data respective of a plurality of points within the lumen, each of the points being associated with the three-dimensional coordinate system, each of the points being further associated with a respective activity state of the organ; determining a temporal three-dimensional trajectory representation for each of the respective activity states from the acquired MPS data which is associated with the respective activity state; superimposing the temporal three-dimensional trajectory representations on the two-dimensional image, according to the respective activity state; receiving position data respective of the selected position, by selecting at least one of the points along the temporal three-dimensional trajectory representa-

tion; determining the coordinates of the selected position in the three-dimensional coordinate system, from the selected at least one point; determining the current position of the medical device in the three-dimensional coordinate system, according to an output of an MPS sensor attached to the catheter in the vicinity of the medical device; maneuvering the medical device through the lumen, toward the selected position, according to the current position relative to the selected position; and producing a notification output when the current position substantially matches the selected position.

[0024] U.S. Pat. No. 6,666,863 to Wentzel et al., which is incorporated herein by reference, describes devices and methods for performing percutaneous myocardial revascularization (PMR). An embodiment is described in which a detector of an ablation controller provides a detect signal when a sensor block output signal indicates that a first electrode is touching the wall of the heart. The ablation controller may also provide a detect signal when the heart is in a less vulnerable portion of the cardiac rhythm, such as when the ventricles of the heart are contracting. As such, the ablation controller is described as helping to identify when the first electrode is in contact with the wall of the heart, thereby reducing the likelihood that an ablation will be triggered when the first electrode is not in contact with the endocardium of the heart and cause damage to the blood platelets within the heart.

[0025] U.S. Pat. No. 5,176,619 to Segalowitz, which is incorporated herein by reference, describes a heart-assist device which includes a flexible catheter carrying at least a ventricular balloon, such balloon corresponding in size and shape to the size and shape of the left ventricle in the heart being assisted, the ventricular balloon being progressively inflated creating a wave-like pushing effect and deflated synchronously and automatically by means of a control console which responds to heart signals from the catheter or elsewhere.

[0026] PCT Publication WO 94/010904 to Nardella, which is incorporated herein by reference, describes an ablation catheter that has an ablation electrode at a distal end coupled to an ablation power source through a low impedance coupling. In some embodiments, ablation only occurs while the heart is in a desired part of the cardiac cycle, the ablation power intervals being triggered by timing pulses synchronized with detection of the R wave. This mode of actuation is described as assuring that the heart is essentially stationary before delivery of ablation energy, thus minimizing the risk of inadvertently ablating healthy tissue.

[0027] An article by Boyle et al., entitled "Assessment of a Novel Angiographic Image Stabilization System for Percutaneous Coronary Intervention" (Journal of Interventional Cardiology, Vol. 20 No. 2, 2007), which is incorporated herein by reference, describes a system for stabilizing angiographic images at a region of interest in order to assist during percutaneous coronary intervention (PCI).

[0028] An article by Timinger et al., entitled "Motion compensated coronary interventional navigation by means of diaphragm tracking and elastic motion models" (Phys Med Biol. 2005 Feb. 7; 50(3):491-503), which is incorporated herein by reference, presents a method for compensating the location of an interventional device measured by a magnetic tracking system for organ motion and thus registering it dynamically to a 3D virtual roadmap. The motion compensation is accomplished by using an elastic motion model which is driven by

the ECG signal and a respiratory sensor signal derived from ultrasonic diaphragm tracking.

[0029] An article by Timinger et al., entitled "Motion compensation for interventional navigation on 3D static roadmaps based on an affine model and gating" (Phys Med Biol. 2004 Mar. 7; 49(5):719-32), which is incorporated herein by reference, describes a method for enabling cardiac interventional navigation on motion-compensated 3D static roadmaps.

[0030] An article by Turski et al., entitled "Digital Subtraction Angiography 'Road Map'" (American Journal of Roentgenology, 1982), which is incorporated herein by reference, describes a technique called roadmapping. An arterial roadmap for the subsequent manipulation of catheters under fluoroscopy is generated by means of first injecting a contrast agent into said arteries and using the resulting, "highlighted" arterial image as a background to the real-time fluoroscopic imaging of the catheterization procedure.

[0031] An article by Iddan et al., entitled "3D imaging in the studio and elsewhere" (SPIE Proceedings Vol. 4298 2001), which is incorporated herein by reference, describes the technique of background subtraction and replacement of video images, which has been used in TV studios.

[0032] The following patents and patent applications, which are incorporated herein by reference, may be of interest:

- [0033]** U.S. Pat. No. 5,830,222 to Makower
- [0034]** U.S. Pat. No. 4,245,647 to Randall
- [0035]** U.S. Pat. No. 4,316,218 to Gay
- [0036]** U.S. Pat. No. 4,849,906 to Chodos et al.
- [0037]** U.S. Pat. No. 5,062,056 to Lo et al.
- [0038]** U.S. Pat. No. 5,630,414 to Horbaschek
- [0039]** U.S. Pat. No. 6,442,415 to Bis et al.
- [0040]** U.S. Pat. No. 6,473,635 to Rasche
- [0041]** U.S. Pat. No. 4,920,413 to Nakamura
- [0042]** U.S. Pat. No. 6,233,478 to Liu
- [0043]** U.S. Pat. No. 5,764,723 to Weinberger
- [0044]** U.S. Pat. No. 5,619,995 to Lobodzinski
- [0045]** U.S. Pat. No. 4,991,589 to Hongo et al.
- [0046]** U.S. Pat. No. 5,538,494 to Matsuda
- [0047]** U.S. Pat. No. 5,020,516 to Biondi
- [0048]** U.S. Pat. No. 7,209,779 to Kaufman
- [0049]** U.S. Pat. No. 6,858,003 to Evans et al.
- [0050]** U.S. Pat. No. 6,786,896 to Madhani et al.
- [0051]** U.S. Pat. No. 6,999,852 to Green
- [0052]** U.S. Pat. No. 7,155,315 to Niemeyer et al.
- [0053]** U.S. Pat. No. 5,971,976 to Wang et al.
- [0054]** U.S. Pat. No. 6,377,011 to Ben-Ur
- [0055]** U.S. Pat. No. 6,711,436 to Duhaylongsod
- [0056]** U.S. Pat. No. 7,269,457 to Shafer
- [0057]** U.S. Pat. No. 6,959,266 to Mostafavi
- [0058]** U.S. Pat. No. 7,191,100 to Mostafavi
- [0059]** U.S. Pat. No. 6,708,052 to Mao et al.
- [0060]** U.S. Pat. No. 7,180,976 to Wink et al.
- [0061]** U.S. Pat. No. 7,085,342 to Younis et al.
- [0062]** U.S. Pat. No. 6,731,973 to Voith
- [0063]** U.S. Pat. No. 6,728,566 to Subramanyan
- [0064]** U.S. Pat. No. 5,766,208 to McEwan
- [0065]** U.S. Pat. No. 6,704,593 to Stainsby
- [0066]** U.S. Pat. No. 6,973,202 to Mostafavi
- [0067]** US Patent Application Publication 2007/0173861 to Strommer
- [0068]** US Patent Application Publication 2007/0208388 to Jahns

- [0069] US Patent Application Publication 2007/0219630 to Chu
- [0070] US Patent Application Publication 2004/0176681 to Mao et al.
- [0071] US Patent Application Publication 2005/0090737 to Burrel et al.
- [0072] US Patent Application Publication 2006/0287595 to Maschke
- [0073] US Patent Application Publication 2007/0142907 to Moaddeb et al.
- [0074] US Patent Application Publication 2007/0106146 to Altmann et al.
- [0075] US Patent Application Publication 2005/0054916 to Mostafavi
- [0076] US Patent Application Publication 2003/0018251 to Solomon
- [0077] US Patent Application Publication 2002/0049375 to Strommer et al.
- [0078] US Patent Application Publication 2005/0137661 to Sra
- [0079] US Patent Application Publication 2005/0143777 to Sra
- [0080] US Patent Application Publication 2004/0077941 to Reddy et al.
- [0081] PCT Publication WO 06/066122 to Sra
- [0082] PCT Publication WO 06/066124 to Sra
- [0083] PCT Publication WO 05/026891 to Mostafavi
- [0084] PCT Publication WO 01/43642 to Heuscher
- [0085] PCT Publication WO 03/096894 to Ho et al.
- [0086] PCT Publication WO 05/124689 to Manzke
- [0087] The following articles, which are incorporated herein by reference, may be of interest:
- [0088] "Catheter Insertion Simulation with Combined Visual and Haptic Feedback," by Zorcolo et al. (Center for Advanced Studies, Research and Development in Sardinia)
- [0089] "New 4-D imaging for real-time intraoperative MRI: adaptive 4-D scan," by Tokuda et al. (Med Image Comput Assist Interv Int Conf. 2006; 9(Pt 1):454-61)
- [0090] "Real-time interactive viewing of 4D kinematic MR joint studies," by Schulz et al. (Med Image Comput Assist Interv Int Conf. 2005; 8(Pt 1):467-73.)
- [0091] "Prospective motion correction of X-ray images for coronary interventions," by Shechter et al. (IEEE Trans Med Imaging. 2005 April; 24(4):441-50)
- [0092] "Cardiac Imaging: We Got the Beat!" by Elizabeth Morgan (Medical Imaging, March 2005)
- [0093] "Noninvasive Coronary Angiography by Retrospectively ECG-Gated Multislice Spiral CT," by Achenbach et al., (Circulation. 2000 Dec. 5; 102(23):2823-8)
- [0094] "Full-scale clinical implementation of a video based respiratory gating system," by Ramsey et al., (Engineering in Medicine and Biology Society, 2000. Proceedings of the 22nd Annual International Conference of the IEEE, 2000, Volume: 3, 2141-2144)
- [0095] "Spatially-adaptive temporal smoothing for reconstruction of dynamic and gated image sequences," by Brankov et al., (Nuclear Science Symposium Conference Record, 2000 IEEE, 2000, Volume: 2, 15/146-15/150)
- [0096] "4D smoothing of gated SPECT images using a left-ventricle shape model and a deformable mesh," by Brankov et al., (Nuclear Science Symposium Conference Record, 2004 IEEE, October 2004, Volume: 5, 2845-2848)

[0097] "4D-CT imaging of a volume influenced by respiratory motion on multi-slice CT Tinsu Pan," by Lee et al., (Medical Physics, February 2004, Volume 31, Issue 2, pp. 333-340)

[0098] "Three-Dimensional Respiratory-Gated MR Angiography of the Coronary Arteries: Comparison with Conventional Coronary Angiography," by Post et al., (AJR, 1996; 166: 1399-1404)

SUMMARY OF THE INVENTION

[0099] In some embodiments of the invention, apparatus and methods are used for facilitating medical procedures performed on cyclically-moving organs, so that such procedures are performed under a partial or full virtual stabilization of such organs. In some embodiments, the stabilization comprises at least one of the following elements: the stabilization of image(s) being viewed with respect to the motion of an organ, and the actuation of tool(s) applied to the organ in synchronization with the organ's motion.

[0100] In some embodiments, continuously-generated image frames of cyclically-moving organs are gated to one or more physiological signals or processes, wherein the cycle(s) of such signals or processes correspond to a motion cycle of the organ being imaged. Consequently, the displayed gated image frames of the organ are typically all in a selected same phase of a motion cycle of the organ.

[0101] In some embodiments, the gated images are displayed with a smoothed transition filling the gaps among them, generating a synthesized, continuous video stream.

[0102] In some embodiments, image tracking is applied to continuously-generated images of moving organs, to align such images to one another. The motion to which such tracking is applied may be cyclical, or non-cyclical, or a combination of both. The visual effect of such motion is typically reduced by the image tracking.

[0103] In some embodiments, a combination of the aforementioned gating, tracking and/or gap filling are applied to generate a stabilized image stream.

[0104] In some embodiments, road mapping is applied to the stabilized image stream. In some embodiments, roadmapping is applied to the stabilized image stream to facilitate a medical procedure that is performed on the moving organ.

[0105] In some embodiments, the actuation or movement of one or more medical tools applied to a cyclically-moving organ is synchronized with one or more physiological signals or processes whose cycle(s) corresponds to a motion cycle of the organ. Consequently, the tool is typically actuated only during one or more selected same phases in a motion cycle of the organ. In some embodiments, the synchronized actuation of medical tools controls the application of linear motion, angular motion, energy, substance delivery, or any combination thereof.

[0106] In some embodiments, the aforementioned stabilized imaging and synchronized tool application are applied jointly to a cyclically moving organ. In some embodiments, images of the organ are stabilized with respect to a given phase of the cycle, and the actuation of the tool is synchronized to the same phase. In some embodiments, this leads to virtual stabilization of the cyclically-moving organ, both with respect to the imaging of the organ and the tools being moved and/or applied.

[0107] It is noted, however, that the scope of the present invention includes synchronized tool application and/or movement with respect to a cyclically moving organ, using

techniques described herein, even in the absence of stabilized imaging as described herein, or even in the absence of any imaging.

[0108] In some embodiments, the aforementioned techniques are applied to an organ that may not be cyclically moving, but is cyclically active, for example, an organ that undergoes neural cyclic activity.

[0109] There is therefore provided, in accordance with an embodiment of the invention, apparatus for imaging a portion of a body of a subject that moves as a result of cyclic activity of a first body system of the subject and that also undergoes additional motion, the apparatus including:

[0110] an imaging device for acquiring a plurality of image frames of the portion of the subject's body;

[0111] a sensor for sensing a phase of the cyclic activity of the first body system;

[0112] a control unit configured to generate a stabilized set of image frames of the portion of the subject's body:

[0113] by identifying a given phase of the cyclic activity of the first body system, and outputting a set of the image frames corresponding to image frames of the portion acquired during the given phase, and

[0114] by image tracking at least the set of image frames to reduce imaged motion of the portion of the subject's body associated with the additional motion; and

[0115] a display configured to display the stabilized set of image frames of the portion of the subject's body.

[0116] In an embodiment, the control unit is configured to identify the given phase of the cyclic activity using a gating signal, and the display is configured to display a representation of the gating signal simultaneously with displaying the stabilized set of image frames.

[0117] In an embodiment, the display is configured to display an enlarged stabilized set of image frames of a region within the portion of the subject's body.

[0118] In an embodiment, to generate the stabilized set of image frames of the portion of the subject's body, the control unit is configured:

[0119] to identify a first image frame acquired during the given phase,

[0120] subsequently, to image track the first identified image frame,

[0121] subsequently, to identify a second image frame acquired during the given phase, and

[0122] subsequently, to image track the second identified image frame.

[0123] In an embodiment, to generate the stabilized set of image frames of the portion of the subject's body, the control unit is configured:

[0124] to image track a first image frame,

[0125] subsequently, to place the first image tracked frame in the stabilized set of image frames if the first image tracked frame was acquired during the given phase,

[0126] subsequently to image track a second image frame, and

[0127] subsequently, to place the second image tracked frame in the stabilized set of image frames if the second image tracked frame was acquired during the given phase.

[0128] In an embodiment, to generate the stabilized set of image frames of the portion of the subject's body, the control unit is configured:

[0129] to generate a gated set of image frames of the plurality of image frames corresponding to image frames of the portion acquired during the given phase, and

[0130] subsequently, to image track the gated set of image frames.

[0131] In an embodiment, to generate the stabilized set of image frames of the portion of the subject's body, the control unit is configured:

[0132] to image track the plurality of image frames of the portion of the subject's body, and

[0133] subsequently, to generate a set of image frames corresponding to those of the tracked image frames of the portion that were acquired during the given phase.

[0134] In an embodiment, the control unit includes a video tracker selected from the group consisting of: an edge tracker, a centroid tracker, a correlation tracker, and an object tracker, and the control unit is configured to image track the at least the set of image frames using the selected video tracker.

[0135] In an embodiment, the control unit is configured to generate the set of image frames corresponding to image frames of the portion acquired during the given phase by controlling the imaging device to acquire the plurality of image frames only when the cyclic activity is at the given phase.

[0136] In an embodiment,

[0137] the imaging device is configured to acquire the plurality of image frames throughout the cyclic activity, and

[0138] the control unit is configured to generate the set of image frames corresponding to image frames of the portion acquired during the given phase, by selecting image frames corresponding to image frames of the portion acquired during the given phase from the plurality of image frames.

[0139] In an embodiment, the apparatus further includes a user interface, and the control unit is configured to receive an input from a user, via the user interface, and to select a phase of the cyclic activity as being the given phase in response to the input.

[0140] In an embodiment, the display is configured to display the plurality of acquired image frames simultaneously with displaying the stabilized set of image frames.

[0141] In an embodiment, the apparatus is configured for the display to display the stabilized set of image frames in real time with respect to the acquisition of the plurality of image frames by the imaging device.

[0142] In an embodiment, the apparatus is configured for the display to display the stabilized set of image frames within 4 seconds of the imaging device having imaged the plurality of image frames.

[0143] In an embodiment, the apparatus is configured for the display to display the stabilized set of image frames less than two cycles of the cyclic activity after the imaging device imaged the plurality of image frames.

[0144] In an embodiment, the apparatus is configured for the display to display the stabilized set of image frames during a medical procedure during which the imaging device images the plurality of image frames.

[0145] In an embodiment, the apparatus is configured to display the stabilized set of image frames subsequent to a medical procedure during which the imaging device imaged the plurality of image frames.

[0146] In an embodiment, the apparatus further includes a data storage unit configured to store the stabilized set of image frames.

[0147] In an embodiment, the control unit is configured to enhance the stabilized set of image frames by image processing the stabilized set of image frames.

[0148] In an embodiment, the additional motion is not associated with cyclic activity of the subject's body, and the control unit is configured to reduce the imaged motion associated with the additional motion that is not associated with cyclic activity, by image tracking at least the set of image frames.

[0149] In an embodiment, the additional motion is associated with whole-body motion of the subject, and the control unit is configured to reduce the imaged motion associated with the whole-body motion by image tracking at least the set of image frames.

[0150] In an embodiment, the apparatus further includes:

[0151] a contrast agent; and

[0152] an injection tool configured to inject the contrast agent into a space within the portion of the subject's body, and

[0153] the imaging device is configured to acquire at least one image frame of the space during the given phase, at a time when at least some of the contrast agent is present within the space, and

[0154] the display is configured to display the at least one image frame of the space overlaid on at least one same one of the stabilized set of image frames.

[0155] In an embodiment,

[0156] the imaging device is configured to acquire a first image frame of the space during the given phase of a first cycle of the cyclic activity, at a time when at least some of the contrast agent is present within the space,

[0157] the imaging device is configured to acquire a second image frame of the space during the given phase of a second cycle of the cyclic activity, at a time when at least some of the contrast agent is present within the space, and

[0158] the display is configured to display the first and the second image frame of the space overlaid on at least one same frame of the stabilized set of image frames.

[0159] In an embodiment,

[0160] the space includes a lumen containing an occlusion,

[0161] the injection tool is configured to inject the contrast agent into the lumen on a proximal side of the occlusion and on a distal side of the occlusion,

[0162] the imaging device is configured to acquire at least one image frame of the lumen on the proximal side of the occlusion during the given phase of a cycle of the cyclic activity, at a time when at least some of the contrast agent is present within the lumen on the proximal side of the occlusion,

[0163] the imaging device is configured to acquire at least one image frame of the lumen on the distal side of the occlusion during the given phase of the cycle, at a time when at least some of the contrast agent is present within the lumen on the distal side of the occlusion, and

[0164] the display is configured to display the at least one image frame of the lumen on the proximal side of the occlusion and the at least one image frame of the lumen on the distal side of the occlusion overlaid on at least one same frame of the stabilized set of image frames.

[0165] In an embodiment,

[0166] the space includes a lumen containing an occlusion,

[0167] the injection tool is configured to inject the contrast agent into the lumen on a proximal side of the occlusion and on a distal side of the occlusion,

[0168] the imaging device is configured to acquire at least one image frame of the lumen on the proximal side of the occlusion during the given phase of a first cycle of the cyclic

activity, at a time when at least some of the contrast agent is present within the lumen on the proximal side of the occlusion,

[0169] the imaging device is configured to acquire at least one image frame of the lumen on the distal side of the occlusion during the given phase of a second cycle of the cyclic activity, at a time when at least some of the contrast agent is present within the lumen on the distal side of the occlusion, and

[0170] the display is configured to display the at least one image frame of the lumen on the proximal side of the occlusion and the at least one image frame of the lumen on the distal side of the occlusion overlaid on at least one same frame of the stabilized set of image frames.

[0171] In an embodiment,

[0172] the space includes a lumen containing an occlusion,

[0173] the injection tool is configured to inject the contrast agent into the lumen on a proximal side of the occlusion,

[0174] the apparatus further includes a second injection tool configured to inject the contrast agent into the lumen on a distal side of the occlusion,

[0175] the imaging device is configured to acquire at least one image frame of the lumen on the proximal side of the occlusion during the given phase of a cycle of the cyclic activity, at a time when at least some of the contrast agent is present within the lumen on the proximal side of the occlusion,

[0176] the imaging device is configured to acquire at least one image frame of the lumen on the distal side of the occlusion during the given phase of the cycle, at a time when at least some of the contrast agent is present within the lumen on the distal side of the occlusion, and

[0177] the display is configured to display the at least one image frame of the lumen on the proximal side of the occlusion and the at least one image frame of the lumen on the distal side of the occlusion overlaid on at least one same frame of the stabilized set of image frames.

[0178] In an embodiment,

[0179] the space includes a lumen containing an occlusion,

[0180] the injection tool is configured to inject the contrast agent into the lumen on a proximal side of the occlusion,

[0181] the apparatus further includes a second injection tool configured to inject the contrast agent into the lumen on a distal side of the occlusion,

[0182] the imaging device is configured to acquire at least one image frame of the lumen on the proximal side of the occlusion during the given phase of a first cycle of the cyclic activity, at a time when at least some of the contrast agent is present within the lumen on the proximal side of the occlusion,

[0183] the imaging device is configured to acquire at least one image frame of the lumen on the distal side of the occlusion during the given phase of a second cycle of the cyclic activity, at a time when at least some of the contrast agent is present within the lumen on the distal side of the occlusion, and

[0184] the display is configured to display the at least one image frame of the lumen on the proximal side of the occlusion and the at least one image frame of the lumen on the distal side of the occlusion overlaid on at least one same frame of the stabilized set of image frames.

[0185] In an embodiment, the imaging device includes a fluoroscope.

[0186] In an embodiment, the space includes a space selected from the group consisting of a chamber of a heart of the subject, a lumen of a coronary blood vessel of the subject, and a lumen of an aorta of the subject, and the injection tool is configured to inject the contrast agent into the selected space.

[0187] In an embodiment, the control unit is configured to construct at least one three-dimensional image frame of the space, during the given phase, based on image frames acquired at the time when at least some of the contrast agent is present within the space.

[0188] In an embodiment, the apparatus further includes a medical tool configured to be inserted into the space, the apparatus is configured to acquire an image of the tool while the tool is inside the space, and the display is configured to display the image of the tool overlaid on the image frame of the space.

[0189] In an embodiment, the control unit is configured to identify when the injection tool injects the contrast agent by image processing a set of image frames of the space.

[0190] In an embodiment, the control unit is configured to identify when the injection tool injects the contrast agent by specifically analyzing a region of at least some of the plurality of image frames that corresponds to a vicinity of a distal tip of the injection tool.

[0191] In an embodiment, the control unit is configured to identify when the injection tool injects the contrast agent by determining a level of darkness of the region of at least some of the plurality of image frames that corresponds to the vicinity of the distal tip of the injection tool.

[0192] In an embodiment, the apparatus further includes a user interface, and the display is configured to receive an input from a user, via the user interface, and to display a marking at a given position within the portion of the subject's body within the stabilized set of image frames, in response to the input.

[0193] In an embodiment, the display is configured to display two or more views of the stabilized set of image frames of the portion of the subject's body, and to display the marking at the given position within respective views of the stabilized set of image frames.

[0194] In an embodiment, the imaging device is further configured to image a plurality of images of a medical tool disposed within the portion of the subject's body, and the control unit is configured to generate a stabilized set of image frames of the medical tool.

[0195] In an embodiment, the medical tool includes a medical tool that is implanted within the portion of the subject's body, and the imaging device is configured to image a plurality of images of the implanted medical tool.

[0196] In an embodiment, the medical tool includes a medical tool that is transiently inserted within the portion of the subject's body, and the imaging device is configured to image a plurality of images of the medical tool while it is inserted within the portion.

[0197] In an embodiment, the control unit is configured to enhance the stabilized set of image frames of the medical tool by image processing the stabilized set of image frames of the medical tool.

[0198] In an embodiment, the control unit is configured to determine a physiological parameter of the subject by analyzing the stabilized set of image frames.

[0199] In an embodiment, the control unit is configured to determine a parameter relating to cardiac function of the subject by analyzing the stabilized set of image frames.

[0200] In an embodiment, the control unit is configured to determine a parameter relating to respiratory function of the subject by analyzing the stabilized set of image frames.

[0201] In an embodiment, in generating the stabilized set of image frames, the control unit is configured to smoothen a transition between successive frames of the set of frames.

[0202] In an embodiment, the control unit is configured to smoothen the transition between the successive frames, by:

[0203] determining a characteristic of motion of an object within the stabilized set of image frames by image processing frames of the stabilized set of image frames,

[0204] generating a simulated image of the object by assuming that the object continues to move according to the determined profile, and

[0205] using the simulated image of the object as an intermediate image between successive image frames.

[0206] In an embodiment, the control unit is configured to smoothen the transition between the successive frames, by:

[0207] determining a position of an object within a non-gated image frame that was acquired subsequent to a first gated image frame and before a second gated image frame, and

[0208] generating a representation of the object within the stabilized set of image frames before the second gated image frame is generated within the stabilized set of image frames.

[0209] In an embodiment, the control unit is configured to determine a dimension of a region within the portion of the subject's body, by analyzing the stabilized set of image frames.

[0210] In an embodiment, the control unit is configured to output an indication of a size of a medical tool relative to the region within the portion of the subject's body.

[0211] In an embodiment,

[0212] the apparatus further includes a medical tool configured to be inserted into the portion of the subject's body and having a known dimension,

[0213] and the control unit is configured to determine the dimension of the region by comparing a dimension of the tool within the stabilized set of image frames to the known dimension.

[0214] In an embodiment, the medical tool includes markers, the markers being separated from each other by a known distance, and the control unit is configured to determine an orientation at which the medical tool is disposed within the portion of the subject's body by determining a distance between the markers as viewed within the stabilized set of image frames with respect to the known distance.

[0215] In an embodiment, the control unit is configured to generate a simulated image of a virtual medical tool disposed at the orientation within the stabilized set of image frames of the portion of the subject's body, in response to the determining of the distance.

[0216] In an embodiment, the apparatus further includes a user interface, and the control unit is configured to receive an input from a user, via the user interface, and to generate a simulated image of a virtual medical tool disposed within the stabilized set of image frames of the portion of the subject's body, in response to receiving the input.

[0217] In an embodiment, the control unit is configured to output dimensions of a real medical tool that corresponds to the simulated image of the virtual medical tool.

[0218] In an embodiment, the control unit is configured to output the dimensions of the real medical tool by accounting for an orientation at which the virtual medical tool is disposed within the simulated image.

[0219] In an embodiment, the control unit is configured to output the dimensions of the real medical tool by accounting for a curvature of a region of the portion of the subject's body within which region the virtual medical tool is disposed within the simulated image.

[0220] In an embodiment, the control unit is configured to receive a first and a second input from the user and to generate respective simulated images of first and second medical tools being placed within the stabilized set of image frames of the portion of the subject's body, in response to receiving the inputs.

[0221] In an embodiment, the imaging device includes two or more imaging devices, and the control unit is configured to generate two or more stabilized sets of image frames of the portion of the subject's body, the sets of image frames having been imaged by respective imaging devices of the two or more imaging devices.

[0222] In an embodiment, a first imaging device of the two or more imaging devices is configured to image the portion of the subject's body before a medical procedure, a second imaging device of the two or more imaging devices is configured to image the portion of the subject's body during the medical procedure, and the control unit is configured to generate the stabilized sets of image frames during the medical procedure.

[0223] In an embodiment, a first imaging device of the two or more imaging devices is configured to image the portion of the subject's body from outside the portion of the subject's body, and a second imaging device of the two or more imaging devices is configured to image regions within the portion of the subject's body while the second imaging device is disposed at respective locations within the portion of the subject's body.

[0224] In an embodiment, the control unit is configured to associate (a) locations within the stabilized image frames acquired by the first imaging device that correspond to the respective locations of the second imaging device, with (b) respective image frames acquired by the second imaging device while the second imaging device was disposed at the respective locations.

[0225] In an embodiment, the apparatus further includes a medical tool configured to be inserted into the portion of the subject's body to a vicinity of the respective locations while the second imaging device is not disposed at the respective locations, and the control unit is configured to generate (a) respective image frames acquired by the second imaging device while the second imaging device was disposed at the respective locations, when (b) the medical tool is disposed in a vicinity of the respective locations.

[0226] In an embodiment, the first imaging device includes a fluoroscope and the second imaging device includes an intravascular ultrasound probe.

[0227] In an embodiment, the first imaging device includes a CT scanner and the second imaging device includes an intravascular ultrasound probe.

[0228] In an embodiment, the first imaging device is configured to acquire the plurality of image frames before the second imaging device images the regions within the portion of the subject's body.

[0229] In an embodiment, the first imaging device is configured to acquire the plurality of image frames while the second imaging device images the regions within the portion of the subject's body, and the first imaging device is configured to acquire the plurality of image frames by acquiring a plurality of image frames of the second imaging device disposed within the portion.

[0230] In an embodiment,

[0231] the stabilized set of image frames defines a first stabilized set of image frames, and

[0232] the control unit is configured to generate an additional stabilized set of image frames of the portion of the subject's body,

[0233] by identifying a further given phase of the cyclic activity of the first body system, and generating an additional set of the image frames corresponding to image frames of the portion acquired during the further given phase, and

[0234] by image tracking at least some of the additional set of image frames to reduce imaged motion of the portion of the subject's body associated with the additional motion.

[0235] In an embodiment, the given phase includes a systolic phase of a cardiac cycle of the subject and the further given phase includes a diastolic phase of the subject's cardiac cycle, and the control unit is configured to generate sets of image frames which are stabilized respectively to the systolic and to the diastolic phases of the subject's cardiac cycle.

[0236] In an embodiment, the apparatus further includes a user interface, and the control unit is configured to receive an input from a user, via the user interface, and to generate simulated images of a virtual medical tool disposed within the stabilized sets of image frames of the portion of the subject's body at the given phase and at the further given phase, in response to receiving the input.

[0237] In an embodiment, the apparatus further includes a medical tool disposed within the portion of the subject's body, and the control unit is configured to generate stabilized images of the medical tool disposed within the portion of the subject's body respectively at the given phase and at the further given phase.

[0238] In an embodiment, the control unit is configured to determine a physiological parameter of the subject by comparing the additional stabilized set of image frames to the first stabilized set of image frames.

[0239] In an embodiment, the control unit is configured to determine a parameter relating to cardiac function of the subject by comparing the additional stabilized set of image frames to the first stabilized set of image frames.

[0240] In an embodiment, the control unit is configured to determine a parameter relating to respiratory function of the subject by comparing the additional stabilized set of image frames to the first stabilized set of image frames.

[0241] In an embodiment, the cyclic activity includes a cardiac cycle of the subject, and the sensor includes a sensor for sensing a phase of the subject's cardiac cycle.

[0242] In an embodiment, the given phase includes an end-diastolic phase of the subject's cardiac cycle, and the control unit is configured to generate a stabilized set of the image frames corresponding to image frames of the portion acquired during the end-diastolic phase of the subject's cardiac cycle.

[0243] In an embodiment, the sensor includes a blood pressure sensor.

[0244] In an embodiment, the sensor includes an ECG sensor.

[0245] In an embodiment, the sensor includes an image processor configured to sense a phase of the subject's cardiac cycle by comparing image frames of the plurality of image frames to at least one of the image frames of the plurality of image frames.

[0246] In an embodiment, the cyclic activity includes a respiratory cycle of the subject, and the sensor includes a sensor for sensing a phase of the subject's respiratory cycle.

[0247] In an embodiment, the sensor includes an image processor configured to sense a phase of the subject's respiratory cycle by comparing image frames of the plurality of image frames to at least one of the image frames of the plurality of image frames.

[0248] In an embodiment, the additional motion is a result of cyclic activity of a second body system of the subject, and the control unit is configured to reduce imaged motion of the portion of the subject's body associated with the cyclic activity of the second body system by image tracking at least the set of image frames.

[0249] In an embodiment,

[0250] the cyclic activity of the first body system has a greater frequency than the cyclic activity of the second body system, and

[0251] the control unit is configured to generate the stabilized set of image frames of the portion of the subject's body:

[0252] by identifying the given phase of the cyclic activity of the first body system, and outputting the set of the image frames corresponding to image frames of the portion acquired during the given phase, and

[0253] by image tracking at least the set of image frames to reduce imaged motion of the portion of the subject's body associated with the cyclic activity of the second body system.

[0254] In an embodiment,

[0255] the cyclic activity of the first body system has a lower frequency than a frequency of the cyclic activity of the second body system, and

[0256] the control unit is configured to generate the stabilized set of image frames of the portion of the subject's body:

[0257] by identifying the given phase of the cyclic activity of the first body system, and outputting the set of the image frames corresponding to image frames of the portion acquired during the given phase, and

[0258] by image tracking at least the set of image frames to reduce imaged motion of the portion of the subject's body associated with the cyclic activity of the second body system.

[0259] In an embodiment,

[0260] the cyclic activity of the first body system includes a cardiac cycle of the subject,

[0261] the cyclic activity of the second body system includes a respiratory cycle of the subject, and

[0262] the control unit is configured to generate the stabilized set of image frames of the portion of the subject's body:

[0263] by identifying the given phase of the cardiac cycle, and outputting the set of the image frames corresponding to image frames of the portion acquired during the given phase, and

[0264] by image tracking at least the set of image frames to reduce imaged motion of the portion of the subject's body associated with the respiratory cycle.

[0265] In an embodiment,

[0266] the cyclic activity of the first body system includes a respiratory cycle of the subject,

[0267] the cyclic activity of the second body system includes a cardiac cycle of the subject, and

[0268] the control unit is configured to generate the stabilized set of image frames of the portion of the subject's body:

[0269] by identifying the given phase of the respiratory cycle, and outputting the set of the image frames corresponding to image frames of the portion acquired during the given phase, and

[0270] by image tracking at least the set of image frames to reduce imaged motion of the portion of the subject's body associated with the cardiac cycle.

[0271] There is additionally provided, in accordance with an embodiment of the invention, apparatus for imaging a portion of a body of a subject that moves as a result of cyclic activity of a first body system of the subject and that also undergoes additional motion, and for use with an imaging device for acquiring a plurality of image frames of the portion of the subject's body, a sensor for sensing a phase of the cyclic activity of the first body system, and a display configured to display image frames of the portion of the subject's body, the apparatus including:

[0272] a control unit configured to generate a stabilized set of image frames of the portion of the subject's body:

[0273] by identifying a given phase of the cyclic activity of the first body system, and outputting a set of the image frames corresponding to image frames of the portion acquired during the given phase,

[0274] by image tracking at least the set of image frames to reduce imaged motion of the portion of the subject's body associated with the additional motion,

[0275] wherein the control unit is configured to output the stabilized set of image frames to be displayed on the display.

[0276] There is further provided, in accordance with an embodiment of the invention, apparatus for imaging a portion of a body of a subject that moves as a result of cardiac cyclic activity of the subject and that also undergoes additional motion that is at least partially a result of a respiratory cycle of the subject, the apparatus including:

[0277] an imaging device for acquiring a plurality of image frames of the portion of the subject's body;

[0278] a sensor for sensing a phase of the cardiac cyclic activity;

[0279] a control unit configured to generate a stabilized set of image frames of the portion of the subject's body:

[0280] by identifying a given phase of the cardiac cyclic activity, and outputting a set of the image frames corresponding to image frames of the portion acquired during the given phase, and

[0281] by image tracking at least the set of image frames to reduce imaged motion of the portion of the subject's body associated with the additional motion; and

[0282] a display configured to display the stabilized set of image frames of the portion of the subject's body.

[0283] There is additionally provided, in accordance with an embodiment of the invention, apparatus for use with a portion of a body of a subject that moves as a result of cyclic activity of a body system of the subject, the apparatus including:

[0284] a sensor for sensing a phase of the cyclic activity;

[0285] a medical tool configured to perform a function with respect to the portion of the subject's body; and

[0286] a control unit configured:

- [0287]** in a first cycle of the cyclic activity, to move at least a portion of the tool in a given direction, in response to the sensor sensing that the cyclic activity is at a first given phase thereof,
- [0288]** following the given phase in the first cycle and prior to an occurrence of the given phase in a subsequent cycle of the cyclic activity, to inhibit the movement of the at least a portion of the tool, and
- [0289]** in a second cycle of the cyclic activity, subsequent to the inhibiting of the movement, to move the at least a portion of the tool in the given direction, in response to the sensor sensing that the second cycle of the cyclic activity is at the given phase thereof,
- [0290]** without moving the at least a portion of the tool in a direction opposite to the given direction, between (a) moving the at least a portion of the tool in
- [0291]** the given direction in the first cycle, and (b) moving the at least a portion of
- [0292]** the tool in the given direction in the second cycle.
- [0293]** In an embodiment, the control unit is configured to move a center of the tool by moving the portion of the tool in the given direction.
- [0294]** In an embodiment, the tool includes a tool configured to be controlled remotely by a user.
- [0295]** In an embodiment, the control unit is configured to be reversibly coupled to the tool.
- [0296]** In an embodiment, the control unit is integrated into the tool.
- [0297]** In an embodiment, the tool includes a guidewire configured to be moved within the portion of the subject's body.
- [0298]** In an embodiment, the tool is configured to penetrate an occlusion of a lumen of the portion of the subject's body by being advanced through the lumen.
- [0299]** In an embodiment, the tool includes a valve configured to be implanted within the portion of the subject's body by being expanded within the portion, and the control unit is configured to move at least a portion of the valve in the given direction, by moving the at least the portion of the valve in an expansion-related direction.
- [0300]** In an embodiment, the tool includes a septal-closure device configured to be implanted within the portion of the subject's body by being expanded within the portion, and the control unit is configured to move at least a portion of the septal-closure device in the given direction, by moving the at least the portion of the septal-closure device in an expansion-related direction.
- [0301]** In an embodiment, the cyclic activity includes a respiratory cycle of the subject, and the sensor is configured to sense a phase of the respiratory cycle.
- [0302]** In an embodiment, the sensor includes an image processor configured to sense a phase of the subject's respiratory cycle by comparing image frames of a plurality of image frames of the portion of the subject's body to at least one of the image frames of the plurality of image frames.
- [0303]** In an embodiment, the cyclic activity includes a cardiac cycle of the subject, and the sensor is configured to sense a phase of the cardiac cycle.
- [0304]** In an embodiment, the sensor includes a blood pressure sensor.
- [0305]** In an embodiment, the sensor includes an image processor configured to sense a phase of the subject's cardiac

cycle, by comparing image frames of the plurality of image frames to at least one of the image frames of the plurality of image frames.

- [0306]** In an embodiment, the sensor includes an ECG sensor configured to sense a phase of the cardiac cycle by detecting an ECG signal of the subject.
- [0307]** In an embodiment, the tool includes a balloon configured to be inflated inside a lumen of the portion of the subject's body, and the control unit is configured to move at least a portion of the balloon in the given direction, by moving a surface of the balloon in an inflation-related direction.
- [0308]** In an embodiment, the control unit is configured to inflate the balloon continuously for a period of time prior to the first cycle of the cyclic activity.
- [0309]** In an embodiment, the control unit is configured to inflate the balloon continuously for a period of time subsequent to the second cycle of the cyclic activity.
- [0310]** In an embodiment, the apparatus further includes a stent, and the stent is configured to be positioned against a wall of the lumen via the inflation of the balloon.
- [0311]** In an embodiment, the apparatus further includes a valve disposed on the surface of the balloon, and the valve is configured to be expanded via the inflation of the balloon.
- [0312]** In an embodiment, the apparatus further includes a valve configured to control flow to the balloon, and the control unit is configured to regulate movement of the surface of the balloon in the inflation-related direction by controlling the valve.
- [0313]** In an embodiment, the apparatus further includes a tube configured to supply fluid to the balloon, the apparatus further includes one or more squeezing surfaces that are disposed around the tube, and the control unit is configured to inhibit movement of the surface of the balloon in the inflation-related direction by driving a current that causes the squeezing surfaces to squeeze together.
- [0314]** In an embodiment, the cyclic activity includes a cardiac cycle of the subject, the portion of the subject's body includes a portion of a cardiovascular system of the subject that moves as a result of the subject's cardiac cycle, and the balloon is configured to be inflated inside the portion of the cardiovascular system.
- [0315]** In an embodiment, the given phase of the cardiac cycle includes end-diastole, and the control unit is configured to move the surface of the balloon in the inflation-related direction in response to the sensor sensing end-diastole.
- [0316]** In an embodiment, the apparatus further includes an instrument configured to be operated by a user, and the control unit is configured to move the portion of the tool in the given direction, (a) in response to the sensor sensing that the cyclic activity is at the given phase thereof, and (b) in response to the instrument being operated by the user.
- [0317]** In an embodiment, the instrument is configured to provide force feedback to the user that is independent of the cyclic activity.
- [0318]** In an embodiment, the instrument is configured to provide force feedback to the user that is smoothed with respect to the cyclic activity.
- [0319]** In an embodiment, the tool includes a tubular structure configured to bypass an occlusion of a blood vessel within the portion of the subject's body.
- [0320]** In an embodiment, the tubular structure includes a blood vessel graft.
- [0321]** In an embodiment, the control unit is configured to move the tubular structure in the given direction by moving a

distal end of the structure in a direction from (a) within the blood vessel on a proximal side of the occlusion, to (b) outside the blood vessel.

[0322] In an embodiment, the control unit is configured to move the tubular structure in the given direction by moving a distal end of the structure in a direction from (a) outside the blood vessel, to (b) within the blood vessel on a distal side of the occlusion.

[0323] There is further provided, in accordance with an embodiment of the invention, apparatus for use with a portion of a body of a subject that moves as a result of cyclic activity of a body system of the subject, the apparatus including:

[0324] a sensor for sensing a phase of the cyclic activity;

[0325] a medical tool configured to mechanically perform an action during a single cycle of the cyclic activity with respect to the portion of the subject's body; and

[0326] a control unit configured to actuate the tool to mechanically perform the action in response to the sensor sensing that the cyclic activity is at a given phase thereof.

[0327] In an embodiment, the tool includes a balloon configured to apposition itself to a lumen of the portion of the subject's body during the single cycle by being inflated in response to the sensor sensing that the cyclic activity is at the given phase thereof.

[0328] In an embodiment, the balloon is configured to be inflated continuously for a period of time prior to the balloon appositioning itself to the lumen by being inflated during the single cycle.

[0329] In an embodiment, the balloon is configured to be inflated continuously for a period of time subsequent to the balloon appositioning itself to the lumen by being inflated during the single cycle.

[0330] In an embodiment, the tool includes a stent configured to apposition itself to a lumen of the portion of the subject's body by being expanded inside the lumen of the portion of the subject's body during a single cycle of the cyclic activity, in response to the sensor sensing that the cyclic activity is at the given phase thereof.

[0331] In an embodiment, the stent includes a self-expandible portion configured to self-expand inside the lumen of the portion of the subject's body.

[0332] In an embodiment, the tool includes a valve configured to be implanted within the portion of the subject's body by mechanically expanding within the portion, and the control unit is configured to actuate the valve to expand in response to the sensor sensing that the cyclic activity is at the given phase thereof.

[0333] In an embodiment, the cyclic activity includes a cardiac cycle of the subject, and the control unit is configured to actuate the valve to expand in response to the sensor sensing that the cardiac cycle is at the given phase thereof.

[0334] In an embodiment, the given phase includes an end-diastolic phase of the cardiac cycle, and the control unit is configured to actuate the valve to expand in response to the sensor sensing the end-diastolic phase of the cardiac cycle.

[0335] In an embodiment, the tool includes a septal-closure device configured to be implanted within a heart of the subject by mechanically expanding within the heart, and the control unit is configured to actuate the septal-closure device to expand in response to the sensor sensing that cardiac cyclic activity of the subject is at a given phase thereof.

[0336] In an embodiment, the given phase includes an end-diastolic phase of the cardiac cycle, and the control unit is

configured to actuate the septal-closure device to expand in response to the sensor sensing the end-diastolic phase of the cardiac cycle.

[0337] There is further provided, in accordance with an embodiment of the invention, apparatus for use with a portion of a subject's body that undergoes neural cyclic activity, the apparatus including:

[0338] a sensor for sensing a phase of the neural cyclic activity;

[0339] a medical tool configured to perform a function with respect to the portion of the subject's body; and

[0340] a control unit configured to actuate the tool to perform the function, in response to the sensor sensing that the cyclic activity is at a given phase thereof.

[0341] There is additionally provided, in accordance with an embodiment of the present invention, apparatus for use with a portion of a body of a subject that moves as a result of cyclic activity of a body system of the subject, and for use with a sensor for sensing a phase of the cyclic activity, and for use with a medical tool configured to perform a function with respect to the portion of the subject's body, the apparatus including:

[0342] a control unit configured:

[0343] in a first cycle of the cyclic activity, to move at least a portion of the tool in a given direction, in response to the sensor sensing that the cyclic activity is at a given phase thereof,

[0344] following the given phase in the first cycle and prior to an occurrence of the given phase in a subsequent cycle of the cyclic activity, to inhibit the movement of the at least a portion of the tool, and

[0345] in a second cycle of the cyclic activity, subsequent to the inhibiting of the movement, to move the at least a portion of the tool in the given direction, in response to the sensor sensing that the second cycle of the cyclic activity is at the given phase thereof,

[0346] without moving the at least a portion of the tool in a direction opposite to the given direction, between (a) moving the at least a portion of the tool in

[0347] the given direction in the first cycle, and (b) moving the at least a portion of

[0348] the tool in the given direction in the second cycle.

[0349] There is further provided, in accordance with an embodiment of the invention, apparatus for use with a portion of a body of a subject that moves as a result of cyclic activity of a body system of the subject, the apparatus including:

[0350] a sensor for sensing a phase of the cyclic activity;

[0351] a medical tool configured to perform a function with respect to the portion of the subject's body; and

[0352] a control unit configured:

[0353] in a first cycle of the cyclic activity in response to the sensor sensing that the cyclic activity is at a first given phase thereof, to move the tool,

[0354] in a subsequent cycle of the cyclic activity in response to the sensor sensing that the cyclic activity is at the given phase thereof, to actuate the tool to execute an action selected from the group consisting of: performing the function and moving,

[0355] following the given phase in the subsequent cycle and prior to an occurrence of the given phase in a further subsequent cycle of the cyclic activity, to inhibit the selected action of the tool, and

[0356] in the further subsequent cycle of the cyclic activity, subsequent to the inhibiting of the action, and in

response to the sensor sensing that the further subsequent cycle of the cyclic activity is at the given phase thereof, to actuate the tool to execute an action selected from the group.

[0357] In an embodiment, the tool includes a myocardial revascularization tool configured to sequentially apply a revascularization treatment to respective treatment sites within the portion of the subject's body, and the control unit is configured to:

[0358] actuate the tool to perform the function by actuating the tool to apply a revascularization treatment to a treatment site, and

[0359] to move the tool by moving at least a portion of the revascularization tool toward successive treatment sites.

[0360] In an embodiment, the control unit is configured to move the tool by moving the tool to create a defined pattern of treatment sites.

[0361] In an embodiment, the tool includes an ablation tool configured to sequentially ablate respective ablation sites within the portion of the subject's body, and the control unit is configured to:

[0362] actuate the tool to perform the function by actuating the tool to ablate an ablation site, and

[0363] to move the tool by moving at least a portion of the ablation tool toward successive ablation sites.

[0364] In an embodiment, the ablation tool is configured to ablate the ablation sites using an ablation technique selected from the group consisting of: laser ablation, electrocautery, RF ablation, cryogenic ablation, and ultrasound ablation.

[0365] In an embodiment, the control unit is configured to move the at least the portion of the tool by moving the at least the portion of the tool to create a defined pattern of ablation sites.

[0366] In an embodiment, the control unit is configured to apply a Maze procedure to the ablation sites by moving the at least the portion of the tool toward successive ablation sites.

[0367] In an embodiment, the ablation tool is configured to apply a pulmonary vein isolation technique to a heart of the subject by moving the at least the portion of the tool toward successive isolation sites.

[0368] In an embodiment, the tool includes an injection tool, configured to inject a substance within the portion of the subject's body, and the control unit is configured to:

[0369] actuate the tool to perform the function by actuating the tool to inject the substance, and

[0370] to move the tool by moving at least a portion of the tool toward an injection site.

[0371] In an embodiment, the substance includes DNA molecules, and the injection tool is configured to inject the DNA molecules into heart tissue of the subject.

[0372] In an embodiment, the substance includes stem cells, and the injection tool is configured to inject the stem cells into heart tissue of the subject.

[0373] In an embodiment, the tool includes a needle configured to suture tissue within the portion of the subject's body, and the control unit is configured to:

[0374] actuate the tool to perform the function by actuating the tool to suture the tissue, and

[0375] to move the tool by moving the needle toward successive suturing sites.

[0376] In an embodiment, the tissue includes tissue of the subject selected from the group consisting of cardiac tissue and coronary tissue, and the needle is configured to suture the selected tissue.

[0377] In an embodiment, the tool includes a needle configured to aspirate tissue from an aspiration site within the portion of the subject's body, and the control unit is configured to:

[0378] actuate the needle to perform the function by actuating the needle to aspirate the tissue, and

[0379] move the needle by moving the needle toward the aspiration site.

[0380] In an embodiment, the needle is configured to perform trans-thoracic needle aspiration.

[0381] In an embodiment, the needle is configured to perform trans-bronchial needle aspiration.

[0382] There is additionally provided, in accordance with an embodiment of the invention, apparatus for opening an at least partial occlusion of a lumen of a subject's body, the apparatus including:

[0383] a sensor for sensing a phase of the cyclic activity;

[0384] an occlusion-opening tool configured to open the occlusion; and

[0385] a control unit configured:

[0386] in a first cycle of the cyclic activity in response to the sensor sensing that the cyclic activity is at a first given phase thereof, to actuate the tool to perform an occlusion-opening action,

[0387] following the given phase in the first cycle and prior to an occurrence of the given phase in a subsequent cycle of the cyclic activity, to inhibit the action of the tool, and

[0388] in a second cycle of the cyclic activity, subsequent to the inhibiting of the action, and in response to the sensor sensing that the second cycle of the cyclic activity is at the given phase, to actuate the tool to perform the action.

[0389] In an embodiment, after actuating the tool at the given phase of the first cycle and before the actuation of the tool at the given phase of the subsequent cycle, the control unit is configured to retract the tool from the occlusion.

[0390] In an embodiment, the occlusion-opening tool includes a tool configured to open the occlusion by directing acoustic waves toward the occlusion.

[0391] There is further provided, in accordance with an embodiment of the invention, apparatus for use with a portion of a body of a subject that moves as a result of cyclic activity of a body system of the subject, the apparatus including:

[0392] an imaging device for acquiring a plurality of image frames of the portion of the subject's body;

[0393] a sensor for sensing a phase of the cyclic activity;

[0394] a medical tool configured to perform a function with respect to the portion of the subject's body;

[0395] a control unit configured to:

[0396] generate a stabilized set of image frames of the medical tool disposed within the portion of the subject's body,

[0397] actuate the tool to execute an action selected from the group consisting of performing the function and moving, in response to the sensor sensing that the cyclic activity is at a given phase thereof, and

[0398] inhibit the tool from executing the action in response to the sensor sensing that the cyclic activity is not at the given phase; and

[0399] a display configured to facilitate use of the tool by displaying the stabilized set of image frames of the medical tool disposed within the portion of the subject's body.

[0400] In an embodiment, the apparatus further includes a user interface, and the control unit is configured to receive an input from a user, via the user interface, and to designate the given phase in response to the input.

[0401] In an embodiment, the tool includes a valve configured to be implanted within the portion of the subject's body by being expanded within the portion, and the control unit is configured to actuate the valve by expanding the valve.

[0402] In an embodiment, the tool includes a septal-closure device configured to be implanted within the portion of the subject's body by being expanded within the portion, and the control unit is configured to actuate the septal-closure device by expanding the septal closure device.

[0403] In an embodiment, the tool includes a balloon configured to perform the function by being inflated inside a lumen of the portion of the subject's body.

[0404] In an embodiment, the tool includes a tubular structure configured to bypass an occlusion of a blood vessel within the portion of the subject's body.

[0405] In an embodiment, the tool includes a myocardial revascularization tool configured to sequentially apply a revascularization treatment to respective treatment sites within the portion of the subject's body, and the control unit is configured to:

[0406] actuate the tool to perform the function by actuating the tool to apply a revascularization treatment to a treatment site, and

[0407] move the tool by moving at least a portion of the revascularization tool toward successive treatment sites.

[0408] In an embodiment, the tool includes an ablation tool configured to sequentially ablate respective ablation sites within the portion of the subject's body, and the control unit is configured to:

[0409] actuate the tool to perform the function by actuating the tool to ablate an ablation site, and

[0410] move the tool by moving at least a portion of the ablation tool toward successive ablation sites.

[0411] In an embodiment, the tool includes an injection tool configured to inject a substance within the portion of the subject's body and the control unit is configured to:

[0412] actuate the tool to perform the function by actuating the tool to inject the substance, and

[0413] move the tool by moving at least a portion of the tool toward an injection site.

[0414] In an embodiment, the tool includes a needle configured to suture tissue within the portion of the subject's body, and the control unit is configured to:

[0415] actuate the tool to perform the function by actuating the tool to suture the tissue, and

[0416] move the tool by moving the needle toward successive suturing sites.

[0417] In an embodiment, the tool includes a needle configured to aspirate tissue from an aspiration site within the portion of the subject's body, and the control unit is configured to:

[0418] actuate the needle to perform the function by actuating the needle to aspirate the tissue, and

[0419] move the needle by moving the needle toward the aspiration site.

[0420] In an embodiment, the tool includes an occlusion-opening tool configured to perform the function by performing an occlusion-opening action on an at least partial occlusion of a lumen of the portion of the subject's body.

[0421] In an embodiment, the tool is configured to perform the occlusion-opening action by moving toward the occlusion, and after actuating the tool at the given phase of a first cycle and before the actuation of the tool at the given phase of a subsequent cycle, the control unit is configured to retract the tool from the occlusion.

[0422] In an embodiment, the control unit is configured to generate the stabilized set of image frames by image tracking at least some of the plurality of image frames to reduce imaged motion of the portion of the subject's body associated with the cyclic activity.

[0423] In an embodiment, the control unit is configured to generate the stabilized set of image frames by generating a set of tracked image frames corresponding to image frames of the portion acquired during the given phase.

[0424] In an embodiment, the control unit is configured to generate the stabilized set of image frames by generating a set of the image frames corresponding to image frames of the portion acquired during the given phase.

[0425] In an embodiment, the control unit is configured to reduce imaged motion of the portion of the subject's body associated with motion of the portion of the subject's body by image tracking the set of image frames.

[0426] In an embodiment, the control unit is configured to generate the set of image frames corresponding to image frames of the portion acquired during the given phase, by actuating the imaging device to acquire the plurality of image frames only when the cyclic activity is at the given phase.

[0427] In an embodiment, the imaging device is configured to acquire the plurality of image frames throughout the cyclic activity, and the control unit is configured to generate the set of image frames corresponding to image frames of the portion acquired during the given phase by selecting image frames corresponding to image frames of the portion acquired during the given phase from the plurality of image frames.

[0428] In an embodiment, the control unit is configured to generate an additional stabilized set of image frames of the portion of the subject's body, by identifying a further given phase of the cyclic activity of the body system, and generating a set of the image frames corresponding to image frames of the portion acquired during the further given phase.

[0429] In an embodiment, the cyclic activity includes a cardiac cycle of the subject, and the sensor includes a sensor for sensing a phase of the subject's cardiac cycle.

[0430] In an embodiment, the given phase includes an end-diastolic phase of the subject's cardiac cycle, and the control unit is configured to generate a stabilized set of the image frames corresponding to image frames of the portion acquired during the end-diastolic phase of the subject's cardiac cycle.

[0431] In an embodiment, the sensor includes an image processor configured to sense movement of the portion of the subject's body by comparing image frames of the plurality of image frames to at least one of the plurality of image frames.

[0432] In an embodiment, the cyclic activity includes a respiratory cycle of the subject, and the sensor includes a sensor for sensing a phase of the subject's respiratory cycle.

[0433] In an embodiment, the sensor includes an image processor configured to sense movement of the portion of the subject's body by comparing image frames of the plurality of image frames to at least one of the plurality of image frames.

[0434] In an embodiment, the apparatus further includes an instrument configured to be operated by a user, and the control unit is configured to actuate the tool to perform the function, (a) in response to the sensor sensing that the cyclic

activity is at the given phase thereof, and (b) in response to the instrument being operated by the user.

[0435] In an embodiment, the instrument is configured to provide force feedback to the user that is independent of the cyclic activity.

[0436] In an embodiment, the instrument is configured to provide force feedback to the user that is smoothed with respect to the cyclic activity.

[0437] There is further provided, in accordance with an embodiment of the invention, apparatus for use with a portion of a body of a subject that moves as a result of cyclic activity of a body system of the subject, and for use with an imaging device for acquiring a plurality of image frames of the portion of the subject's body, a sensor for sensing a phase of the cyclic activity, a medical tool configured to perform a function with respect to the portion of the subject's body, and a display configured to facilitate use of the tool by displaying image frames of the portion of the subject's body, the apparatus including:

[0438] a control unit configured to:

[0439] generate a stabilized set of image frames of the portion of the subject's body,

[0440] output the stabilized set of image frames to the display,

[0441] actuate the tool to perform the function in response to the sensor sensing that the cyclic activity is at a given phase of the cyclic activity, and

[0442] inhibit the tool from performing the function in response to the sensor sensing that the cyclic activity is not at the given phase.

[0443] There is additionally provided, in accordance with an embodiment of the present invention, apparatus for use with a portion of a body of a subject that moves as a result of cyclic activity of a body system of the subject, the apparatus including:

[0444] an imaging device for acquiring a plurality of image frames of the portion of the subject's body;

[0445] a sensor for sensing a phase of the cyclic activity;

[0446] a medical tool configured to mechanically perform an action during a single cycle of the cyclic activity with respect to the portion of the subject's body; and

[0447] a control unit configured to:

[0448] generate a stabilized set of image frames of the portion of the subject's body, and

[0449] actuate the tool to mechanically perform the action in response to the sensor sensing that the cyclic activity is at a given phase thereof.

[0450] In an embodiment, the control unit is configured to generate the stabilized set of image frames by generating a set of image frames that are stabilized with respect to the given phase of the cyclic activity.

[0451] In an embodiment, the tool includes a balloon configured to apposition itself to a lumen of the portion of the subject's body during a single cycle by being inflated, in response to the sensor sensing that the cyclic activity is at the given phase thereof.

[0452] In an embodiment, the tool includes a stent configured to be implanted by being expanded inside a lumen of the portion of the subject's body during a single cycle of the cyclic activity, in response to the sensor sensing that the cyclic activity is at the given phase thereof.

[0453] In an embodiment, the tool includes a valve configured to be implanted within the portion of the subject's body by mechanically expanding within the portion during a single

cycle of the cyclic activity, in response to the sensor sensing that the cyclic activity is at the given phase thereof.

[0454] In an embodiment, the tool includes a septal-closure device configured to be implanted within a heart of the subject by mechanically expanding within the heart during a single cycle of cardiac cyclic activity of the subject, in response to the sensor sensing that the cyclic activity is at the given phase thereof.

[0455] The present invention will be more fully understood from the following detailed description of embodiments thereof, taken together with the drawings, in which:

BRIEF DESCRIPTION OF THE DRAWINGS

[0456] FIG. 1 is a schematic illustration of apparatus for generating a stabilized image of a portion of a subject's body, in accordance with an embodiment of the present invention;

[0457] FIG. 2 is a schematic illustration of a heart at various phases of the cardiac cycle alongside an ECG signal associated with the cardiac cycle;

[0458] FIG. 3 is a schematic illustration of image frames of a subject's heart being gated to a phase of a physiological cycle, in accordance with an embodiment of the present invention;

[0459] FIG. 4 is a schematic illustration of image frames of a subject's heart being image tracked, in accordance with an embodiment of the present invention;

[0460] FIG. 5 is a schematic illustration of image frames of a subject's heart being (a) gated to a phase of a physiological cycle, and (b) image tracked, in accordance with an embodiment of the present invention;

[0461] FIG. 6 is a schematic illustration of apparatus for synchronizing actuation of a medical device with a physiological cycle, in accordance with an embodiment of the present invention;

[0462] FIGS. 7A-B are schematic illustrations of the actuation of inflation of a balloon in synchronization with a physiological cycle, in accordance with an embodiment of the present invention;

[0463] FIG. 7C is a graph schematically showing the pressure of the balloon as a function of time, in accordance with an embodiment of the present invention;

[0464] FIG. 8 is a schematic illustration of apparatus for facilitating the synchronized inflation of a balloon, in accordance with an embodiment of the present invention;

[0465] FIGS. 9-11 are schematic illustrations of apparatus for facilitating the synchronized inflation of a balloon, in accordance with another embodiment of the present invention;

[0466] FIG. 12 is a schematic illustration of apparatus for facilitating the synchronized inflation of a balloon, the apparatus being built into an inflation device, in accordance with a further embodiment of the present invention;

[0467] FIG. 13 is a schematic illustration of synchronization of the penetration of an occlusion of a blood vessel with cyclic movement of the blood vessel, in accordance with an embodiment of the present invention;

[0468] FIG. 14 is a schematic illustration of a modulator for synchronizing the penetration of an occlusion of a blood vessel with the cyclic movement of the blood vessel, in accordance with an embodiment of the present invention;

[0469] FIG. 15 is a schematic illustration of a handheld actuator that comprises the modulator shown in FIG. 14, in accordance with an embodiment of the present invention; and

[0470] FIG. 16 is a schematic illustration of the synchronization of a transluminal placement of a coronary bypass graft with the cyclic motion of a portion of the subject's body, in accordance with an embodiment of the present invention.

DETAILED DESCRIPTION OF EMBODIMENTS

[0471] As used herein:

[0472] The term "physiological signal or process" refers to any cyclical physiological signal or process in the patient's body including, but not limited to, ECG, blood pressure (e.g., systolic and diastolic), Peripheral Arterial Tone, EEG, respiration, the shifting/expansion/contraction of an organ, acquired images in which any of the above signals or processes may be observed, or any combination, derivation, extrapolation or manipulation thereof.

[0473] The terms "medical tool," "tool" and "probe" mean any type of a diagnostic or therapeutic or other functional tool including, but not limited to, a cardiovascular catheter, a stent delivery and/or placement and/or retrieval tool, a balloon delivery and/or placement and/or retrieval tool, a valve delivery and/or placement and/or retrieval tool, a graft delivery and/or placement and/or retrieval tool, a tool for the delivery and/or placement and/or retrieval of an implantable device or of parts of such device, an implantable device or parts thereof, a guide wire, a suturing tool, a biopsy tool, an aspiration tool, a navigational tool, a localization tool, a probe comprising one or more location sensors, a tissue characterization probe, a probe for the analysis of fluid, a measurement probe, an electrophysiological probe, a stimulation probe, an ablation tool, a tool for penetrating or opening partial or total occlusions in blood vessels, a drug or substance delivery tool, a chemotherapy tool, a photodynamic therapy tool, a brachytherapy tool, a local irradiation tool, a laser device, a tool for delivering energy, a tool for delivering markers or biomarkers, a tool for delivering biological glue, an irrigation device, a suction device, a ventilation device, a device for delivering and/or placing and/or retrieving a lead of an electrophysiological device, a lead of an electrophysiological device, a pacing device, an imaging device, a sensing probe, a probe comprising an optical fiber, a robotic tool, a tool that is controlled remotely, or any combination thereof.

[0474] The terms "image" and "imaging" refer to any type of medical imaging, typically presented as a sequence of images and including ionizing radiation, non-ionizing radiation, video, fluoroscopy, angiography, ultrasound, CT, MRI, PET, PET-CT, CT angiography, SPECT, Gamma camera imaging, Optical Coherence Tomography (OCT), Vibration Response Imaging (VRI), Optical Imaging, infrared imaging, electrical mapping imaging, other forms of Functional Imaging, or any combination or fusion thereof. Examples of ultrasound imaging include Endo-Bronchial Ultrasound (EBUS), Trans-Thoracic Echo (TTE), Trans-Esophageal Echo (TEE), Intra-Vascular Ultrasound (IVUS), Intra-Cardiac Ultrasound (ICE), etc.

[0475] The terms "periodic" and "cyclical," when used in the context of the motion of a body organ, are interchangeable.

[0476] The terms "gating" and "synchronization," and their various derivations, when used in the context of

synchronizing between an image display and one or more physiological signals or processes or between the activation of a medical tool and one or more physiological signals or processes, are interchangeable. (The term "coherence" has also been known to describe the same.)

[0477] The terms "stationary" and "stabilized," when used in the context of displayed images, mean a display of a series of images in a manner such that the periodic or cyclical motion of the body organ(s) being imaged is typically, partially or fully, reduced or not noticeable to the viewer. Typically, such images are gated to one or more physiological signals or processes whose cycle(s) correspond to a motion cycle of the organ being imaged.

[0478] The term "virtual stabilization," when used in reference to a moving organ, refers to a situation where the displayed images of said organ are stabilized, partially or fully, with respect to the motion of the organ, and/or tool(s) applied to the organ are actuated in synchronization with a selected phase in the motion of the organ. (Motion of the organ may comprise cyclical and non-cyclical motion.) Consequently, the moving organ is typically viewed and/or acted upon as if it is in a situation of (partial or full) virtual stabilization.

[0479] The terms "synchronizing" and "gating," and derivations thereof, when used in reference to an image stream, describes the identification and selection of individual image frames from such image stream, wherein such frames are acquired at a same selected phase in a plurality of occurrences of a cyclical physiological signal or process.

[0480] The term "gating," and derivations thereof, when used in reference to a medical tool, describes the movement and/or application of the tool at a same selected phase in a plurality of occurrences of a cyclical physiological signal or process.

[0481] The term "image tracking" is used to describe a process by which images (including images acquired at different phases in the motion of an organ) are aligned to one another by means of aligning among such images one or more features, or regions of interest, that are observable in most or all images. The term should be construed to be synonymous with the terms "video tracking," "frame tracking," and "object tracking."

[0482] The term "real time," when used in reference to the application of virtual stabilization or of an element thereof, means without a noticeable delay.

[0483] The term "near real time," when used in reference to the application of virtual stabilization or of an element thereof, means with a short noticeable delay (such as approximately one or two motion cycles of the applicable organ, and, in the case of procedures relating to organs or vessels the motion of which are primarily as a result of the cardiac cycle, less than 4 seconds).

[0484] In some embodiments, apparatus and methods are provided for facilitating medical procedures performed on cyclically-moving organs, so that such procedures are performed under a partial or full virtual stabilization of such organs. The virtual stabilization typically comprises two elements, namely (a) the stabilization of the image(s) of the organ and (b) the synchronization of tool(s) being actuated and/or moved, with the movement of the organ. At least one of these two major elements is applied.

[0485] Examples of organs which move cyclically include, but are not limited to, the heart, the coronary blood vessels,

the aorta, certain other blood vessels (e.g., renal, carotid), the majority of the respiratory tract, certain parts of the digestive tract (e.g., the stomach, the small intestine), certain parts of the thorax (e.g., the diaphragm), the eyes, etc. The description hereinbelow relates mainly to the example of the body organ being the heart and/or the coronary blood vessels, and the physiological signal used for synchronization or gating in such examples is typically the ECG. However, the scope of the invention includes applying the apparatus and methods described hereinbelow to any portion of a subject's body that moves as a result of the cyclic activity of a body-system of the subject.

[0486] Reference is now made to FIG. 1, which is a schematic illustration of apparatus for acquiring image frames of a portion of a subject's heart, in accordance with an embodiment of the present invention. An angiographic/fluoroscopic camera 11 acquires a plurality of image frames, throughout the cyclic activity of the heart. When the image frames are not stabilized, an image or video stream 14 is generated, which is blurred due to the cyclical motion of the imaged heart.

[0487] In some embodiments, the apparatus generates a stabilized video stream 15 by a gating procedure performed by processor 13 in response to an ECG signal 12, a blood pressure sensor, a displacement sensor, a vibration sensor and/or any combinations or derivations thereof, thus yielding said stabilized image or video stream 15. Alternatively or additionally, the image frames are gated with respect to the subject's respiratory cycle. In some embodiments, the subject's respiratory cycle is detected by means of a respiration sensor, such as a stretch belt, a displacement sensor, a vibration sensor, and/or any combinations or derivations thereof.

[0488] In some embodiments, the aforementioned gating is performed directly in conjunction with the actual expansion and contraction of the heart muscle in the course of the cardiac cycle, as such expansion process is observed by the fluoroscopic/angiographic camera, discerning by means of image processing the relative distances among identifiable features such as the coronary blood vessels.

[0489] In some embodiments, gating is performed initially with respect to the ECG signal, or to another signal corresponding to cardiac motion, and/or to any combination or derivation of signals thereof, but afterwards gating is performed by means of image processing. For example, an image frame corresponding to a selected phase in the ECG signal is identified and determined to be a "baseline image frame." After such identification of a "baseline image frame" has been achieved, gating of the subsequent image stream is done by means of selecting those image frames where the shape of the observed anatomy is identical, or most similar, to the shape observed in the baseline image frame.

[0490] For some applications, the aforementioned gating is applied directly to the radiation source of the fluoroscopic/angiographic camera, so that imaging is performed intermittently, e.g., only during or leading up to one or more specific phases in the cardiac cycle at which the acquisition of a (gated) image frame is desired.

[0491] Techniques described herein, above or below, may be practiced in combination with techniques described in one or more of the references cited in the Background section of this application.

[0492] The stabilized image frames are typically produced at the rate of the patient's heart rate. The resulting frame rate is typically one or two frames per second, which is considered a low-frame rate compared to what the human eye interprets

as continuous. In some embodiments, a gap filling technique is applied among the image frames that were selected for display by the gating. Additional intermediate image frames are generated, thus increasing the visible frame rate, typically smoothening the transitions among the gated and displayed images and making the image stream easier to observe. In some embodiments, such gap filling utilizes image processing methods such as blending, morphing or a combination thereof.

[0493] In some embodiments, the gap-filling techniques include a predictive algorithm that is applied to generate image frames after the most recent gated and displayed image frame, but prior to the next gated and displayed image frame. For example, an image processor determines a characteristic of motion of the tool, based upon previously-acquired image frames. The motion profile is extrapolated to generate a simulated image frame of the tool by assuming that the tool continues to move according to the determined profile. The simulated image frame is then used as an intermediate image between successive image frames.

[0494] In some embodiments of the gap-filling, visual information from images that were acquired in the original image stream, but are not displayed in the gated image stream, may be used to discern some of the changes that have occurred since the most recent gated and displayed image. Those changes are then applied to the most recent gated and displayed image, to generate new image frames ahead of the next gated and displayed image. For example, in a beating heart wherein medical tools are manipulated, such visual information may comprise changes in tool positions relative to visible anatomical landmarks that move together with the heart. Such changes are then applied to the most recent gated and displayed image, leading to a representation of the tool being generated and displayed within the stabilized video stream ahead of the next gated and displayed image frame.

[0495] The gap filling described hereinabove is applied by processor 13. Typically, it is applied in the transition between every two consecutive gated image frames. The resulting, stabilized video stream is typically displayed in the course of the procedure, and typically in real time or in near real time.

[0496] In some embodiments, the stabilized video stream is stored and is displayed subsequent to the procedure in which the image frames are acquired.

[0497] In some embodiments, two or more of the streams of images, including the original "jumpy" images and the "smoothened" gated images, are displayed side by side (which may be achieved using two or more separate physical displays, or using two or more software windows within the same physical display).

[0498] In some embodiments, the "smoothened," gated image stream is displayed in a shared manner on the same display that is used for other purposes in the procedure room, such as on an existing "main" or "reference" or "re-loop" display in a coronary catheterization lab.

[0499] Reference is now made to FIG. 2, which is a schematic illustration of a heart at various phases of the cardiac cycle alongside an ECG signal associated with the cardiac cycle. FIG. 2 illustrates the correspondence between triggering points 21, 22 and 23 in the ECG trace and phases 24, 25 and 26 in the cardiac cycle. Different points in the ECG trace typically correspond to different phases in the cardiac cycle. The volume and shape of the heart typically vary throughout the cardiac cycle. The displayed images of the pulsating heart may be gated to any of these points or phases. In some

embodiments, the heart may therefore be continuously viewed at a specific volume and/or shape.

[0500] In some embodiments, an operator (e.g., an interventional cardiologist) shifts the phase point to view the cardiac image at any desired phase in the cycle of the ECG signal, via an input to processor **13** (shown in FIG. **1**). In some embodiments, the specific phase of the cardiac cycle to which the displayed images are gated may be changed by the operator in the course of viewing the images.

[0501] In some embodiments, the stabilized video stream is gated specifically to the end of the diastolic phase of the cardiac cycle. (At the end-diastolic phase the ventricles are typically at their peak volume.) In addition, the inventors hypothesize that the coronary blood vessels may be spread apart at the end-diastolic phase of the cardiac cycle, and, for example, in the case of an angioplasty procedure, that may be the view most desired by a physician. Alternatively the stabilized video stream is gated to a different phase of the subject's cardiac cycle, for example, systole, or mid-diastole.

[0502] In some embodiments, more than one stabilized video stream is displayed concurrently. For example, a stabilized video stream at a diastolic phase of the cardiac cycle is displayed concurrently with another stabilized video stream at a systolic phase of the cardiac cycle.

[0503] In some embodiments, the gated images at different phases of the cardiac cycle form a basis for determining a parameter of the subject's cardiovascular system, for example, the ejection fraction of the heart (using image processing techniques known in the art, *mutatis mutandis*). In some embodiments, image streams are stabilized with respect to two or more phases of the subject's respiratory cycle, and a parameter of the subject's respiratory cycle is determined using one, or both of the image streams, for example, by comparing the image streams to each other. For example, the subject's tidal volume may be determined by determining from the image streams the size of the subject's lungs at the end of the exhalation phase of the subject's respiratory cycle and the size of the subject's lungs at the end of the inhalation phase of the cycle.

[0504] In some embodiments, processor **13** (FIG. **1**) stabilizes the image of the portion of the subject's body with respect to additional motion of the portion. Some physiological signals or processes correspond to a change in the shape of the organs being imaged. Other signals or processes mainly correspond to a change in the location of such organs but have less of a correspondence to their shape. In some cases, signals or processes of those two categories apply to a certain organ or organs concurrently. For example, in the case of the heart and the coronary blood vessels, those organs typically twist, contract and expand in the course of the cardiac cycle (also corresponding to the ECG signal), while at the same time they also typically shift up and down in the course of the respiratory cycle. In addition, such organs may shift in a non-cyclical manner due to "whole-body motion" of the subject, for example, due to the subject coughing or moving on his/her bed. ("Whole-body motion" is to be understood as referring to non-cyclical, noticeable motion of an external portion of the subject's body, even in the absence of the subject's entire body moving.)

[0505] In some embodiments, for the creation of a stabilized video stream of the organ(s) being imaged, a cyclical signal or process typically corresponding to a change in the shape(s) of such organ(s) is accounted for by means of gating. Subsequently, another signal or process, typically corre-

sponding mainly to a change in the location of such organs, is accounted for by means of an image tracker. For example, in the case of the heart and/or associated blood vessels, gating to the ECG signal is applied to create one or more video streams, each of which is stabilized with respect to a specific phase in the cardiac cycle. Image tracking is then applied to the aforementioned gated video stream(s) in order to further stabilize the stream(s) with respect to the respiratory cycle.

[0506] In some embodiments, gating followed by image tracking is applied to respective image frames, in a frame-by-frame manner, such that an individual gated frame is image tracked prior to the next gated frame being acquired. Alternatively, gating is applied to a batch of image frames to generate a set of gated image frames. Image tracking is then applied to the set of gated image frames.

[0507] In some embodiments, the image tracker is applied to motion that is typically not of a cyclical nature, such as whole-body motion of the patient in the course of the procedure. As a result, such motion of the patient is absent from, or substantially reduced in, the stabilized image stream being viewed by the physician.

[0508] The sequence in which the aforementioned gating, image tracking and gap filling are applied to images in the originally-acquired image stream may vary.

[0509] In some embodiments, and for the purpose of creating a stabilized video stream of a cyclically-moving organ, the typically higher frequency of two physiological signals or processes corresponding to a motion of said organ is gated, and subsequently the signal or process which is typically of a lower frequency, and/or any additional motion of the organ, is accounted for by means of image tracking. For example, such sequence may reduce the computational resources required for image stabilization. Alternatively, the typically lower frequency of the two physiological signals or processes is gated, and the signal or process which is typically of a higher frequency, and/or any additional motion of the organ, is accounted for by means of image tracking.

[0510] In some embodiments, the stabilization of the video stream of the cyclically-moving organ is achieved by accounting for the second aforementioned signal or process by means of image tracking prior to (and not following) accounting for the first aforementioned signal or process by means of gating. For example, such a sequence may be useful in some of the aforementioned gap-filling algorithms.

[0511] Specifically, for some applications, visual information of changes in tool positions relative to anatomical landmarks is easier to identify in image tracked images before the images are gated.

[0512] In some embodiments, image tracking followed by gating is applied to respective image frames (typically, in real time or near real time). Alternatively, a batch of image frames are image tracked and subsequently the tracked image frames are gated.

[0513] In some embodiments, image frames are gated with respect to the respiratory cycle, and are image-tracked with respect to movement related to the subject's cardiac cycle.

[0514] The image tracker applied in the aforementioned embodiments may be an edge tracker, a centroid tracker, a correlation tracker, an object tracker, or any combination thereof. Such image tracker typically neutralizes, in the eyes of the viewer of a stabilized video stream, the change in location of the organs being imaged, thus maintaining the organ at a desired location on the display (such as its center), even though the organ being imaged is in constant motion.

[0515] Reference is now made to FIG. 3 which is a schematic illustration of a video stream 33 of a subject's heart being gated to a phase of the subject's cardiac cycle, in accordance with an embodiment of the present invention. A video camera 31, acquires a video stream 33 of the subject's heart. An ECG 32 detects the subject's cardiac cycle. A gating processor 34 of control unit 13 (FIG. 1) selects image frames 35 corresponding to a given phase of the cardiac cycle as reflected by a given point in ECG 32. In some embodiments, a buffer 36 is used for gap filling the transitions among images 35. The resulting stabilized video stream is presented on display 37. Reference is now made to FIG. 4, which is a schematic illustration of a video stream 41 of a subject's heart being image tracked, in accordance with an embodiment of the present invention. Typically, video stream 41 is the output of gating processor 34 (FIG. 3). A mask 45 is generated from image frames of video stream 41 of the subject's heart. Both mask 45 and the image frames are fed into a correlator 42. Correlator 42 identifies mask 45 in each new image frame, and by doing so identifies the deviation in the location of the mask within the current image frame relative to its location in the prior image frame. Image corrector 43 utilizes the output of correlator 42 for realigning each new image frame such that the relative location of mask 45 within each such new image frame remains constant. Consequently, tracked video stream 44 is produced. In embodiments in which the input to correlator 42 and image corrector 43 is the output of gating processor 34 (FIG. 3), video stream 44 is both image tracked and gated to a given point in the ECG.

[0516] Reference is now made to FIG. 5, which is a schematic illustration of a video stream of a subject's heart being (a) gated 51 to a phase of a physiological cycle (as described with reference to FIG. 3), and (b) image tracked 52 (as described with reference to FIG. 4), in accordance with an embodiment of the present invention. The combined application of processes 51 and 52 typically results in a video stream that is stabilized with respect to changes in the shape as well as the location of the organ(s) being imaged.

[0517] Typically, when using the combined application of gating and image tracking as in the sequence shown in FIG. 5, the aforementioned smoothening or gap filling in the transformations among selected image frames is performed on the output of the gating and the image tracking (i.e., on the output of FIG. 5). In such a case, each individual image frame which is an output of the gating serves as an input for image tracking. After going through both gating and image tracking, each individual frame becomes both gated and image tracked, and the gap filling is performed on the transformations between successive gated-and-image-tracked frames.

[0518] It is noted that, as described, the scope of the present invention also includes performing image tracking prior to performing gating (configuration not shown in the figures). In this case, the smoothening algorithms described herein are generally applied to the output of the gating.

[0519] In some embodiments, a path for passing tools into desired locations in the heart and/or coronary blood vessels is generated. In some embodiments, such a path is also displayed.

[0520] In some embodiments, stabilized road mapping is applied to cyclically-moving organs such as the coronary blood vessels, the pulmonary vessels, the aorta, and/or to the heart itself. Road mapping is typically helpful in reducing radiation time and/or the amount of contrast agent being used to facilitate medical procedures. Road mapping is commonly

used in catheterization procedures in organs that can typically remain motionless throughout the procedure, such as blood vessels in the limbs. One embodiment of road mapping is named Digital Subtraction Angiography (DSA).

[0521] The use of road mapping is typically difficult with conventional, constantly moving cardiac images, because the historical roadmap and the displayed images are typically not aligned with one another most of the time. Thus, road mapping is typically not used in procedures performed on moving organs, such as coronary interventions.

[0522] In some embodiments of the current invention, a historical roadmap which was generated in the same phase of the cardiac cycle to which the displayed, stabilized video stream is gated and from the same viewing angle, is displayed as a background to the real-time, stabilized video stream. (In some embodiments, the aforementioned use of image tracking is also applied, for example, in order to compensate for the effect of the respiratory cycle.) The roadmapping typically generates an image of the coronary vessels highlighted with a contrast agent. Consequently, the real-time image of tools inserted through such vessels is typically viewed as superimposed on the roadmap of those same vessels at the same gated phase in the cardiac cycle. In some embodiments, by generating a stabilized roadmap, manipulation of tools is facilitated, and/or cumulative radiation throughout the procedure is reduced, and/or the cumulative amount of contrast agent injected throughout the procedure is smaller.

[0523] Typically the contrast agent is injected into a space within the subject's cardiovascular system, for example, a chamber of the subject's heart, a coronary blood vessel, and/or the subject's aorta.

[0524] In some embodiments, using roadmapping facilitates the direct stenting of the subject's coronary arteries, without requiring a prior step of pre-dilatation. In such embodiments, the roadmap typically improves the ability to place the stent accurately and thus reduces the need to inflate a balloon which does not carry a stent prior to the deployment of the stent itself. That, in turn, typically reduces procedure time and/or cost.

[0525] In some embodiments, direct stenting as described herein is capable of reducing the risk of embolization which may otherwise be created if pre-dilatation is performed at a slightly different location from that of the subsequent deployment of the stent. If such a difference in location exists, then the occluding substance or tissue that is being inflated and fragmented by a pre-dilatation balloon may not be subsequently kept in place by the stent, and thus embolization might occur.

[0526] Generation of the aforementioned roadmap is typically benefited by knowledge by the system of when contrast agent is being injected. In some embodiments, the injection of contrast agent for highlighting the vessels is sensed, for the purpose of generating the aforementioned roadmap, via an electrical signal indicating the activation of the injection subsystem. Alternatively or additionally, the injection of contrast agent for highlighting the vessels is identified by means of image processing. Further alternatively or additionally, the injection of contrast agent for highlighting the vessels is identified by means of analyzing changes in the image (such as via a histogram) of the region at the distal end of the catheter from which the contrast agent typically comes out (such as a guiding catheter in the case of coronary road mapping). Changes in the image include a relatively abrupt change in the color and/or grayscale level (darkness) of a

relatively large number and/or portion of image pixels, or the appearance of vessel-like features in the image, etc., or any combination thereof. It is noted that by assessing a change in the darkness level to identify the time of injection of the contrast agent, the control unit may identify a darker area of the image or a lighter area of the image, depending on whether the contrast agent is represented as dark or light. It is additionally noted that whereas specifically assessing the region at the distal end of the catheter typically enhances signal to noise (because this region is most likely to show an abrupt change), the scope of the present invention includes assessing all of the acquired image data to identify the injection of the contrast agent.

[0527] In some embodiments, the road map being displayed in conjunction with the stabilized video stream loops among multiple images of different moments in the injection and dissipation process of the contrast agent, wherein all of those images were originally gated to a same phase in the cardiac cycle to which the currently-displayed, stabilized video stream is gated.

[0528] In some embodiments, the road map being displayed in conjunction with the stabilized video stream comprises an image of the contrast agent itself. In some embodiments, the road map comprises a synthesized background(s), enhancement(s), contour(s), pattern(s), texture(s), shade(s) and/or color(s) that was created based upon the visual information acquired from the injection and/or dissipation of contrast agent, using computer graphics and/or image processing techniques. In some embodiments, the gray level of the road map is inverted, such that the road map appears light against a darkened background.

[0529] In some embodiments, the summation or combination of two road maps generated at different times in the procedure is displayed. In some embodiments, a road map generated during a given phase of a first cardiac cycle is summed with a road map generated during a same phase of a second (typically immediately subsequent) cardiac cycle, to create a combined road map that displays more coronary vessels and/or displays coronary vessels with greater clarity. In some embodiments, in the case of a total or partial occlusion in a coronary vessel, the combined road map may comprise the summation or combination of a roadmap created from an injection of a contrast agent proximally to the occlusion, and a second road map created from an injection of a contrast agent distally to the occlusion, such as via a collateral vessel and/or in a retrograde direction. In these embodiments, the roadmaps based on the proximally- and distally-injected contrast agent are created in the same phase of one or more cardiac cycles that are not necessarily adjacent cardiac cycles.

[0530] In some embodiments, a three-dimensional road map is constructed by combining two or more two-dimensional road maps recorded from viewing angles that are typically different by 30 degrees or more. In some embodiments, the two two-dimensional road maps (from which a three-dimensional road map is constructed) are recorded concurrently from two different viewing angles by means of a bi-plane fluoroscopy system. In some embodiments, a three-dimensional road map is created from CT angiography images, typically pre-procedural ones, and then correlated with the real-time two-dimensional road map created from intra-procedural angiography. In some embodiments, a three-dimensional road map is constructed from two or more different images taken from the same viewing angle but during different phases in the cardiac cycle.

[0531] In some embodiments, markings are applied upon the stabilized images. For example, in the case of coronary angioplasty, such markings may be applied to the longitudinal edges of an occlusion, or to the region in which pre-dilatation was performed, etc. In some embodiments, such markings are applied manually with an input device such as a computer mouse, or by a stylet in the case of a tablet computer. In some embodiments, such markings are applied by hand on a touch screen. In some embodiments, such markings appear to the viewer, throughout subsequent changes in the viewing angle and/or zoom level or the fluoroscopy/angiography system, as if they remain attached to the blood vessels to which they refer. Such virtual attachment is typically performed by means of image processing. In some embodiments, the markings comprise a scale or a grid that is generated on the stabilized image, to indicate to the physician the dimensions of the image.

[0532] In some embodiments, on-line geometric and/or hemodynamic measurements (e.g., size, flow, ejection fraction) are made and/or displayed upon the stabilized images. "On-line" in this context means that the measurements are made on the stabilized image stream, as opposed to being made on frozen images extracted from an image stream. For example, in the case of angioplasty, such measurements, also known as Quantitative Coronary Analysis (QCA), may include the length and inner diameter(s) of the occlusion and be used as inputs for the selection of a balloon and/or a stent. In some embodiments, the known size of an object seen in the stabilized images, such as the outer diameter of an introducing catheter or the size of a patch adhered to the patient's chest or the distance between radiopaque markers on a tool, is used as a reference in making such measurements. In some embodiments, the orientation at which the medical tool is disposed within the subject's body is determined, by determining an apparent distance between radiopaque markers on a tool within the stabilized set of image frames, with respect to the known distance of the markers from each other. In some embodiments, the physical size corresponding to an image pixel, as known from the imaging system, is used as a reference (in which case no physical reference object is required).

[0533] In some embodiments, the deployment of an endovascular device, for example a balloon or a stent, is visually simulated prior to actually being performed. For example, a virtual stent of selected length and diameter may be visually placed and displayed, within the stabilized image stream, as if it were situated at the site of the occlusion. The suitability of the intended dimensions as observed with the virtual stent can then be visually validated by the physician prior to selecting and deploying the physical stent. For some applications, multiple virtual stents, such as in preparation for the stenting of a vascular bifurcation where a physical stent will be required in each branch, are virtually placed and matched with one another prior to their actual deployment. In some embodiments, a virtual stent is placed in proximity to a physical, already-deployed stent to verify that the two match one another prior to deploying the second, physical stent.

[0534] In some embodiments, the proper deployment of a virtual tool is estimated by viewing it upon two stabilized images streams, each corresponding to a different phase of the cardiac cycle. In some embodiments, one such phase is diastolic while the second phase is systolic. In some embodiments, in response to determining an orientation at which a

real medical tool (e.g., a catheter) is disposed within the subject's body, the virtual tool is deployed at a corresponding (e.g., identical) orientation.

[0535] In some embodiments, an operator manipulates an image of a virtual tool deployed within the stabilized image stream, until the virtual tool is of appropriate dimensions. A reference number of a real tool that best corresponds to the dimensions of the virtual stent is generated. (The reference number may be, for example, a catalog number of a real tool.) Alternatively or additionally, the dimensions of a real tool that corresponds to the dimensions of the virtual tool are generated. In some embodiments, image processing is applied to the simulated image of the virtual stent to determine the curvature of a region in which the virtual stent is deployed and dimensions of a real tool are generated that incorporate the curvature of the region. In some embodiments, the orientation of the region in which the virtual tool is deployed is determined in order to generate the dimensions of a corresponding real tool.

[0536] In some embodiments, the proper deployment of an actual stent is assessed by viewing the stent within two stabilized images streams, each corresponding to a different phase of the cardiac cycle. In some embodiments, one such phase is diastolic, while the second phase is systolic.

[0537] In some embodiments, image processing techniques are applied to enhance the image of (a) an endovascular device, and/or (b) radiopaque markers which a device comprises, and/or (c) the walls of the vessel in which the device is situated, within the stabilized image stream. For example, the device may be a balloon and/or a stent that is implanted in the subject's body or that is transiently placed within the subject's body. Typically, such enhancement is more easily generated in a stabilized video stream in which the enhanced object is relatively stable, compared with in a non-stabilized stream of images wherein the object being enhanced is constantly shifting. In accordance with embodiments of the invention, such enhancement may be performed on-line, within the stabilized image stream. Consequently, in such embodiments, proper deployment of the endovascular device being deployed may be verified by the physician during a procedure.

[0538] In some embodiments, the stabilized image stream is used for on-line measurement of the flow within a vessel, by measuring the time it takes contrast agent to travel a known distance. In some embodiments, the stabilized image stream is used for on-line measurement of the saturation of contrast agent within targeted tissue, such as heart muscle.

[0539] In some embodiments, additional images, such as images produced by other modalities in a same or similar phase of the cardiac cycle to which the stabilized video stream is gated, are co-displayed. For some applications, such images are pre-operative, intra-operative, or a combination of the two. Alternatively or additionally, such images are two-dimensional or three-dimensional. The modalities from which such images originate are used before or during coronary procedures and include, without limitation, fluoroscopy, CT, MRI, CT angiography, Trans Esophageal Echo (also known as TEE), Trans Thoracic Echo (also known as TTE), Intra Vascular Ultrasound (also known as IVUS), Intra Cardiac Ultrasound (also known as Intra Cardiac Echo, or ICE), Optical Coherence Tomography, Intra Vascular MRI, or any combination thereof. In some embodiments, the co-display of such images together with the aforementioned gated video stream is performed via fusion (e.g., image overlay), using

image-to-image registration techniques. Such a co-display typically provides the operator with enhanced clinical information.

[0540] (Throughout the specification and the claims, the term "overlay" and derivations thereof, should not be understood to denote a particular order in which two or more images are combined. Rather, it refers generally to the combination of two or more images that are overlaid in space.)

[0541] In some embodiments, a first set of images are acquired by a first imaging device from outside a portion of the subject's body, for example by CT or using a fluoroscope. A second set of images are acquired by a second imaging device from within the portion of the subject's body, for example, using an intra-vascular ultrasound probe, or an intra-vascular MRI probe. In some embodiments, the first set of images are acquired before the second set of images are acquired, and the two sets of images are registered to each other. Alternatively, the first imaging device and the second imaging device acquire the respective sets of image frames simultaneously.

[0542] In some embodiments, images generated by an ultrasound probe (such as IVUS) within a coronary vessel are used in conjunction with the stabilized image stream (such as a stabilized fluoroscopic image stream) in the following manner:

[0543] i. The fluoroscopic image stream is stabilized.

[0544] ii. An IVUS catheter is inserted to the site of an occlusion under fluoroscopic imaging, to inspect endoluminal anatomy.

[0545] iii. The image slices generated by the IVUS are recorded and stored in tandem with the visual location (such as display coordinates) of the distal tip of the IVUS catheter as seen by the fluoroscopy.

[0546] iv. The IVUS catheter is retrieved to make room for balloon/stent deployment.

[0547] v. A catheter with a balloon and/or stent is inserted to the site of the occlusion, under fluoroscopic imaging.

[0548] vi. The location of the distal tip of the catheter carrying the balloon and/or stent is visually recognized (such as via display coordinates).

[0549] vii. The IVUS images previously recorded at the same location are displayed, together with the fluoroscopic images. In some embodiments, the IVUS images are displayed in a separate window (but on the same screen as the fluoroscopic images). In some embodiments, the IVUS images are displayed on a separate screen. In some embodiments, the IVUS images being displayed are two-dimensional (also known as "slices"). In some embodiments, a three-dimensional "tunnel-like" reconstruction of the IVUS images of the vessel (or a section thereof) is displayed. In some embodiments, the IVUS images are overlaid on the fluoroscopic images. In some embodiments, the IVUS images are fused with the fluoroscopic images.

[0550] viii. As a result, the balloon and/or stent may be deployed based upon an on-line combination of real-time fluoroscopic images and of IVUS images recorded earlier (for example, several minutes earlier).

[0551] Although embodiments of the invention are described primarily with reference to the heart, connecting vessels (e.g., aortic, pulmonary) and coronary blood vessels, embodiments of the current invention are similarly applicable to any other organ affected by periodic motion and/or periodic activity. An example for the latter would be the brain.

[0552] Reference is now made to FIG. 6, which is a schematic illustration of apparatus for synchronizing actuation of a medical device with a physiological cycle, in accordance with an embodiment of the present invention. Cyclically-moving organ 61 is imaged by imaging device 62. Non-gated image frames are displayed on display 64. A cyclical physiological signal used for synchronization is transmitted via line 68 to processor 63. Gated image frames are displayed on display 66, which is connected to processor 63. In some embodiments, gap filling is applied to the gated image frames. In some embodiments, such images are also image tracked. Actuator 65 is actuated in a synchronized manner, with respect to the synchronization signal transferred from processor 63 via a line 69. Actuator 65, in turn, controls tool 67, which is applied to organ 61.

[0553] The scope of the present invention includes synchronizing, with respect to a physiological cycle, the actuation and/or movement of a medical device that performs a function on a portion of a subject's body, without stabilizing images of the portion,

[0554] The scope of the present invention includes synchronizing, with respect to a physiological cycle, the actuation and/or movement of a medical device that performs a function on a portion of a subject's body, in combination with stabilizing images of the portion.

[0555] The scope of the present invention includes synchronizing, with respect to a given phase of a physiological cycle, the actuation and/or movement of a medical device that performs a function on a portion of a subject's body, and stabilizing images of the portion with respect to the same given phase of the cycle.

[0556] FIGS. 7A-C and 8 through 12 are schematic illustrations of apparatus for inflation of a balloon, such as for widening an occlusion within a coronary blood vessel, in synchronization with the patient's cardiac cycle, in accordance with respective embodiments of the invention. In some embodiments, a stent, which is positioned around the balloon, is expanded by inflating the balloon. In some embodiments, the embodiments shown in FIGS. 7-12 are practiced in combination with stabilized imaging techniques described hereinabove.

[0557] Typically, the placement and inflation of the balloon is performed in a same selected specific phase of the cardiac cycle. That typically leads to accuracy in the placement of the balloon at a given location.

[0558] In cases where a single cardiac cycle is shorter than the time it takes to easily or safely inflate a coronary balloon, inflation in some embodiments is performed in an intermittent (i.e., a stepwise) manner, in the course of a same selected phase in multiple cardiac cycles (FIG. 7C).

[0559] In other embodiments, one or more segments of the inflation of the balloon is performed continuously (i.e., not in synchronization to the cardiac cycle) and one or more segments of the inflation of the balloon is performed in the aforementioned synchronized, stepwise manner. In one embodiment, synchronized inflation until the balloon becomes fixed to the inner wall of the lumen is followed by continuous inflation until the balloon is inflated to a target diameter or volume. In another embodiment, the balloon is inflated continuously till it reaches a given volume but is not yet fixed to the inner walls of the lumen, followed by synchronized inflation until it becomes fixed to the inner walls of the lumen. In a third embodiment, the balloon is first inflated continuously until it reaches a given volume, then inflated in

a synchronized manner until it becomes attached to the inner wall of the lumen, and then inflated continuously again until it reaches a desired diameter or volume.

[0560] In some embodiments, the aforementioned synchronized placement and inflation are performed while viewing the aforementioned stabilized image as described with reference to FIG. 1.

[0561] In some embodiments, the specific phase to which the inflation of the balloon is synchronized is the end of the diastole phase of the cardiac cycle. At the end-diastolic phase of the cardiac cycle, the ventricles are typically at their fullest volume. Furthermore, the inventors hypothesize that during the end-diastolic phase of the cardiac cycle, the coronary arteries are typically the most spread apart, and typically remain in that situation for a fraction of a second. Such timing may further assist in the correct apposition of a stent positioned upon the balloon. Alternatively or additionally, the inflation of the balloon is gated to a different phase of the subject's cardiac cycle, for example, a mid-diastolic phase or a systolic phase.

[0562] Reference is now made to FIGS. 7A-B, which are schematic illustrations of the actuation of inflation of a balloon 73 in synchronization with a physiological cycle, in accordance with an embodiment of the present invention. As shown in FIG. 7A, blood vessel 71 is clogged by occluding substance or tissue 72. Balloon 73 is positioned at the occlusion and inflated by actuator 75 via a tube. According to some embodiments of the current invention, a synchronization signal derived from the patient's ECG is provided via line 74. The ECG signal is used to trigger the increased inflation pressure of balloon 73 in a stepwise manner, wherein each step occurs in the same selected phase of the ECG cycle. The result is sequence 76 (FIG. 7B), showing the steady, synchronized stepwise inflation of the balloon, until the balloon is typically inflated to the desired extent and at is the desired location.

[0563] In some embodiments, actuator 75 is connected to a typically non-synchronized inflation device. In another embodiment, actuator 75 and the inflation device are integrated together into a single, synchronized inflation device.

[0564] Reference is now made to FIG. 7C, which is a graph showing the pressure 77 of the balloon as a function of time, in accordance with an embodiment of the present invention.

[0565] Reference is now made to FIG. 8, which is a schematic illustration of apparatus for facilitating the synchronized inflation of a balloon 82, in accordance with an embodiment of the present invention. The operator of the device actuates a handle 81 (such as via rotating), in order to inflate balloon 82. Handle 81, by means of control circuit 83, commands driver 84. Driver 84 is synchronized by a train of pulses 85 (which originates from the ECG as explained previously), such that it produces a synchronous output into a torque motor. The torque motor comprises a stator 86 and rotor 87. The torque motor rotates a lead screw 88. Stationary drive nut 89 converts the rotational motion of lead screw 88 into the linear motion of piston 810. The motion of piston 810 inside cylinder 811 pushes the fluid contained within the distal portion of cylinder 811 into inflation tube 812, and from there into balloon 82.

[0566] FIGS. 9-11 are schematic illustrations of apparatus for facilitating the synchronized inflation of a balloon, in accordance with another embodiment of the present invention. Inflation device 91 and balloon catheter 92 are typically the same as those conventionally used for non-synchronized

balloon inflation. In some embodiments, synchronization of balloon inflation to the patient's cardiac cycle is enabled by an accumulator-modulator **93** that is added and is typically connected between inflation device **91** and balloon catheter **92**. The output of inflation device **91**, typically in the form of inflation fluid, feeds accumulator-modulator **93**. The output of accumulator-modulator **93**, typically in the form of inflation fluid, feeds balloon catheter **92**.

[0567] The purpose of accumulator-modulator **93** is to enable intermittent balloon inflation that is performed, in whole or in part, in a stepwise manner and in synchronization with the patient's ECG signal. The modulator part of **93** is typically responsible primarily for the synchronization of the inflation to the ECG. The accumulator part of **93** is typically responsible primarily for maintaining a continuous build-up of the inflation pressure despite the inflation itself being (in whole or in part) intermittent. (Without the accumulator, undesirable increases and decreases in the inflation pressure may occur.)

[0568] FIG. **10** is a schematic illustration of an embodiment of accumulator-modulator **93** described with respect to FIG. **9**. The accumulator unit comprises a loaded piston **101**. The modulator unit comprises valve **102**, driver circuit **103** and internal power supply **104**. Internal power supply **104** is optional, as an alternative to an external power supply. Driver circuit **103** is fed by the ECG-derived synchronization signal via line **107**, and based on that signal drives valve **102** to assume the open and closed positions. In an embodiment, the accumulator-modulator receives its input, typically in the form of inflation fluid, from an inflation device via inlet **105**. The accumulator-modulator typically provides its output, typically in the form of inflation fluid, to a balloon catheter via outlet **106**.

[0569] As noted above, the modulator unit of the accumulator-modulator described with respect to FIG. **9** and FIG. **10** typically comprises a valve that opens and shuts in accordance with the ECG-derived synchronization signal and through which the inflation fluid traverses. Such a valve may comprise any known implementation, including a check valve of any type (e.g., ball check, duckbill, swing check, clapper, stop check), a leaf valve, or any combination thereof.

[0570] FIG. **11** is a detailed schematic illustration of the accumulator-modulator described with respect to FIG. **9** and FIG. **10**, in accordance with an embodiment of the present invention. Inflation fluid traverses flexible tube **111** on its way towards the outlet of the accumulator-modulator. Tube **111** changes intermittently between being open and shut for the flow of such fluid. Two arms **112**, pivoting on axes **115**, intermittently squeeze and release tube **111**. The activation of coil **113** causes arms **112** to pull closer to one another for minimizing the magnetic field reluctance, and thus squeeze tube **111** shut. When coil **113** is deactivated, arms **112** (with the assistance of an optional recoil spring **114**) pull apart and cause tube **111** to open for the passage of inflation fluid.

[0571] Reference is now made to FIG. **12**, which is a schematic illustration of apparatus for facilitating the synchronized inflation of a balloon, the apparatus being built into an inflation device, in accordance with a further embodiment of the present invention. A pressure signal **125** is created by inflation mechanism **126**. An ECG-derived synchronization signal **121** and pressure signal **125** are both fed into controller **122**. A synchronized actuation signal **123** is fed from controller **122** to valve modulator **124**. The output of valve modulator **124**, typically in the form of inflation fluid, is fed into a

balloon catheter that is typically connected distally to the inflation device. As a result, the balloon is inflated gradually, in a stepwise manner, to a desired size.

[0572] Each of the aforementioned balloon inflation apparatuses and methods, described with respect to FIGS. **7** through **12**, may be synchronized either to the patient's ECG signal, blood pressure signal, displacement signal, vibration signal or to a different signal corresponding to the patient's cardiac cycle, or to any combination, derivation, extrapolation or manipulation thereof.

[0573] In some embodiments, the aforementioned balloon inflation apparatuses and methods described with respect to FIGS. **7** through **12** apply not only to the placement and inflation of a balloon, but also to the deployment of a stent which is positioned upon the balloon. Typically, deploying a stent in a virtually stable environment leads to greater accuracy in the placement of the stent at a given location. In some embodiments, other medical tools which are positioned upon the balloon are deployed via the inflation of the balloon. For example, a valve, a graft, a septal-closure device, and/or another medical tool may be deployed via the inflation of the balloon.

[0574] In some embodiments, while causing the inflation of the balloon to occur (in whole or in part) in a stepwise manner in synchronization with the ECG signal, the aforementioned balloon inflation apparatus and methods described with respect to FIGS. **7** through **12** provide the operator of the inflation device with continuous force feedback during inflation. Thus, the operator of the inflation device typically feels as if the balloon inflation process is continuous even though that process, or parts thereof, is in fact intermittent. In some embodiments, the apparatus smoothens the force feedback with respect to the physiological cycle to which the inflation is gated, so that the effect of the stepwise inflation, on the force feedback to the operator, is reduced.

[0575] Although embodiments of synchronizing the actuation, and/or the movement of a tool to a physiological cycle, have been described with respect to a balloon, the scope of the invention includes applying these embodiments to the other medical tools described herein.

[0576] FIGS. **13** through **15** disclose embodiments of the synchronized application of a guide wire, such as for opening an occlusion in a coronary blood vessel, in accordance with an embodiment of the present invention. In some embodiments, application of the guide wire is synchronized either to the patient's ECG signal, or to a different signal corresponding to the patient's cardiac cycle, or to any combination, derivation, extrapolation or manipulation thereof.

[0577] Reference is now made to FIG. **13**, which is a schematic illustration of synchronization of the penetration of an occlusion **132** of a blood vessel **131** with cyclic movement of the blood vessel, in accordance with an embodiment of the present invention. In the case of a total or near-total occlusion, such penetration typically precedes the inflation of a balloon and/or the placement of a stent. Wire **133** penetrates the occlusion in a synchronized, stepwise manner. An actuator **135**, synchronized by signal **134** coming from the patient's ECG, is used to generate the stepwise forward motion as seen in schematic sequence **136**. Typically, such synchronized forward motion of the wire **133** enables these embodiments of the current invention to reduce the probability of perforation or dissection of blood vessel **131** by the guide wire. Conversely, in conventional procedures, such perforation or dissection is known to occur, typically due to pushing the wire at

a phase in the cardiac cycle where the wire actually points at the wall of the vessel and not towards the desired point of entry on the surface of the occlusion.

[0578] In some embodiments, synchronization is made to a phase in the cardiac cycle when the coronary arteries are typically maximally inflated and thus with the largest cross section. Such timing may assist in opening the occlusion.

[0579] In some embodiments, the operator feels as if he or she pushes the wire continuously, while the actuator causes the wire to be pushed intermittently, in synchronization with the ECG signal.

[0580] In some embodiments, the aforementioned synchronization is applied to a tool used for widening or opening occlusions, where the tool is not a guide wire. In some embodiments, synchronization is applied to the tool's motion within the occlusion. In some embodiments, an occlusion-opening tool, for example a tool having jackhammer-like functionality, is moved toward the occlusion during the given phase of respective cycles. Typically, after the tool is moved toward the occlusion at the given phase of a first cycle and before the tool is moved toward the occlusion at the given phase of a subsequent cycle the tool is retracted from the occlusion. In another embodiment, synchronization is used to control the release of energy, for example, ultrasonic energy, aimed at widening or opening the occlusion.

[0581] Reference is now made to FIG. 14, which is a schematic illustration of a modulator for synchronizing the penetration of an occlusion of a blood vessel by a wire 141 with the cyclic movement of the blood vessel, in accordance with an embodiment of the present invention. The modulator generates stepwise motion of wire 141. The modulator disclosed herein is an embodiment based on a self-locking clamp 143 driven by a voice coil incorporating a coil plunger 145 and a permanent magnet stator 146. A return spring 142 is also incorporated. Other modulators capable of generating periodic motion that are known in the art include, but are not limited to, those based on roller wheels, grippers, or piezoelectric or magnetostrictive effects. The modulator is typically housed in shell or housing 144. Wire 141 can be placed into the modulator at any desired position along the wire, for example after the interventional cardiologist has already pushed the wire all the way to the occlusion.

[0582] In some embodiments, similar modulating heads yield rotational motion of the wire by adding a torque generator to the modulator.

[0583] Reference is now made to FIG. 15, which is a schematic illustration of a handheld actuator that comprises the modulator described with respect to FIG. 14, in accordance with an embodiment of the present invention. Electronic circuit 152 conveys a driving signal to modulator 153, in the manner already described with respect to FIG. 14. Control stick 151 controls the motion of guide wire 155. For example, when the operator pushes stick 151 forward, or activates a trigger, the actuator conveys a corresponding train of pulses to modulator 153. These pulses are synchronized via line 154 to the reference signal. The pulse train, when delivered to the modulator, creates the forward motion of the guide wire in a synchronized stepwise manner. Typically, the harder operator pushes control stick 151, the more intense are the pulses, hence wire 155 will move forward at a higher pace. By pulling stick 151 backwards, the guide wire will move correspondingly backwards. In some embodiments, the force feedback provided to control stick 151 is spring loaded. In some embodiments, a force feedback that bears greater resem-

blance to the original force feedback of wire 155 is generated. For example, force feedback that does not vary with respect to the cyclic activity of the blood vessel, or force feedback that is smoothed with respect to the movement of the blood vessel, may be generated.

[0584] In some embodiments, the operator exerts force on guide wire 155 directly, and not indirectly via control stick 151 as is described above.

[0585] In some embodiments, the actuator provides custom force feedback which typically increases its user-friendliness by providing the operator with a more familiar feel. In some embodiments, the actuator (and specifically the control stick) replicates the tactile feedback of specific medical tools, thus increasing its utility to the operator. In some embodiments, a digital library of tool-specific force feedbacks is connected to the actuator. In some embodiments, the force feedback specific to each tool is selected by the operator. In some embodiments, the force feedback specific to each tool is selected automatically, with the actuator identifying the tool (such as via a specific code).

[0586] In some embodiments, the aforementioned actuator controls the application of:

[0587] linear motion,

[0588] angular motion (e.g., for the purpose of turning the tip of the penetrating device and, for example, for leading a drill through an occlusion in a coronary blood vessel synchronized with the cardiac cycle),

[0589] energy (e.g., for radio frequency ablation synchronized with the cardiac cycle, or for percutaneous myocardial revascularization via the application of laser in synchronization with the cardiac cycle),

[0590] substance delivery (e.g., gene therapy for cardiac revascularization synchronized with the cardiac cycle), or

[0591] pressure, such as for inflating a balloon and/or a stent

[0592] any combination thereof.

[0593] In some embodiments, the aforementioned actuator comprises re-usable elements, restricted-reuse elements, single-use elements, or any combination thereof. In some embodiments, the actuator, or elements thereof, are usable only for a specific time period and/or a specific number of uses following their initial activation. In some embodiments, the time period and/or number of uses are coded in a memory element (such as a memory chip) incorporated into the actuator.

[0594] Reference is now made to FIG. 16, which is a schematic illustration of the stepwise transluminal placement of a coronary bypass graft 163 in a coronary blood vessel 161 in order to bypass an occlusion 162, in accordance with an embodiment of the present invention. In the prior art, such an implantation is typically performed during open heart surgery. In such surgery, a bypass is implanted between the proximal and distal sides of a major impairment (such as a total occlusion) in a blood vessel. Embodiments of the current invention, by providing a full or partial virtual stabilization as previously explained, make it possible to connect the proximal and distal sides of impairment 162 without open surgery. Based on a combination of the stabilized image of blood vessel 161 and the synchronous activation (based upon signal 164 and by means of actuator 165) of the tool(s) delivering and placing the graft, the two sides of the impairment are connected transluminally. Typically, images generated from two separate views, sequentially or concurrently (such as

those provided concurrently by a bi-plane fluoroscopy system), are used. Such views typically differ from one another by at least 30 degrees, and in some embodiments they are perpendicular. In some embodiments, the graft is a biological graft. Alternatively, the graft is a synthetic graft.

[0595] In some embodiments, the aforementioned modulator, modulator-accumulator and/or actuator are not hand held. In some embodiments, the aforementioned modulator, modulator-accumulator or actuator are connected to or operated by a medical robot. In some embodiments, the aforementioned modulator, modulator-accumulator and/or actuator are operated in a remote manner via a communications network (e.g., tele-operation).

[0596] For some applications, the aforementioned techniques are applied to an organ that does not move cyclically, but is cyclically active (such as the brain).

[0597] In some embodiments, the synchronized tools disclosed by the current invention are connected to, or operated by, a medical robot.

[0598] The scope of the present invention includes using the techniques of synchronized actuation of a tool, as described hereinabove, for applications other than those described in detail hereinabove. In general, the techniques can be used in combination with the techniques described hereinabove, for stabilized imaging of a cyclically moving organ. In some embodiments, movement of a tool in a given direction or along a desired pattern is synchronized with a physiological cycle. Typically, the tool is moved in the given direction at a given phase of respective physiological cycles without moving the tool in the opposite direction to the given direction, between movements of the tool in the given direction.

[0599] In some embodiments, a tool is moved in a given direction by moving the center of the tool. In some embodiments, at a given phase of respective cycles of a physiological cycle, a tool is actuated either to perform a function, or to move. For some applications, at a given phase of a single cycle of a physiological cycle, a tool is actuated to mechanically perform a function with respect to a portion of the subject's body that moves as a result of the cycle. For example, the techniques described hereinabove can be applied to the following additional procedures:

[0600] Percutaneous placement, replacement or repair of a cardiac valve such as an aortic valve, a mitral valve, a pulmonary valve, or a tricuspid valve. The percutaneous approach may be transvascular or through an incision (such as transapical). It is important to deploy the valve accurately, relative to the surrounding anatomy. Doing so in a beating heart or vessel is often difficult. In accordance with some embodiments of the current invention, a tool carrying a valve is led to, and/or positioned at, and/or actuated to deploy the valve at a desired anatomical location in synchronization with a selected phase of the cardiac cycle. In some embodiments, the selected phase is when the corresponding anatomy is at a peak dimension. In some embodiments, the selected phase of the cycle is when the corresponding anatomy remains stable, or relatively stable, for the longest duration. In some embodiments, the tool and the anatomy are viewed in an image stream that is stabilized at a same selected phase of the cardiac cycle. In some embodiments, the selected phase at which the tool is moved, positioned, activated or applied is the same selected phase at which an observed image stream is stabilized. In some embodi-

ments, the valve is deployed by expanding the valve at the selected phase during a single cycle. Alternatively, the valve is deployed by expanding the valve in a stepwise manner, at the selected phase, during more than one cycle.

[0601] Catheterization of pulmonary arteries, applying the tools and techniques (e.g., guide wire, balloon, stent, occlusion-opening devices) previously described in the context of the coronary arteries. In some embodiments, such a procedure is performed in conjunction with stabilized imaging as described hereinabove. In another embodiment, such a procedure is performed not in conjunction with stabilized imaging, but yet in synchronization with the cardiac cycle, so as to achieve improved deployment of a balloon or a stent, or better penetration of an occlusion.

[0602] Closure of holes in the septal wall, such as Patent Foramen Ovale (PFO) and Atrial Septal Defect (ASD), within the cyclically-moving heart. With embodiments of the current invention, a carrier carrying a closure device is led to, and positioned at, a desired anatomical location (such as the site of the hole in the septum) while both carrier and heart anatomy are viewed in an image stream that is typically stabilized at a selected same phase in the cardiac cycle. Next, the closure device is deployed (including its assembly, expansion and/or release from the carrier) at the desired anatomical location in a selected phase of the cardiac cycle. Such a selected phase is typically the same as the phase selected for the stabilization of the image stream. In some embodiments, the closure device is deployed by expanding the closure device at the selected phase during a single cycle. Alternatively, the closure device is deployed by expanding the closure device in a stepwise manner, at the selected phase, during more than one cycle.

[0603] Placement of a stent graft within the cyclically-moving aorta to treat abdominal aortic aneurysms. In accordance with embodiments of the current invention, a carrier carrying a stent graft is led to, and positioned at, a desired anatomical location (such as the site of the aneurysm) while both carrier and aortic anatomy are viewed in an image stream that is typically stabilized at a selected same phase in the cardiac cycle. Next, the stent graft is deployed (including its assembly, expansion and/or release from the carrier) at the desired anatomical location in a selected phase of the cardiac cycle. Such selected phase is typically the same as the phase selected for the stabilization of the image stream. In other embodiments of the current invention, the graft is deployed at the desired anatomical location in a selected phase of the cardiac cycle (such as when the corresponding section of the target vessel is at its peak dimensions), without observing stabilized imaging. In some embodiments, the stent is a self-expandable stent.

[0604] Localized energy application to a tissue, such as within the heart (e.g., cardiac ablation performed by means of radio frequency ablation, cryoablation, laser, electrocautery, or ultrasound to address cardiac arrhythmia). In some embodiments, the current invention facilitates the ablation of endocardial tissue in a desired pattern, such as a continuous line or a series of lines, for example, to apply a Maze procedure to the tissue. In some embodiments, movement of the ablation tool is

performed in synchronization with a selected phase in the cardiac cycle. In some embodiments, delivery of energy is performed in synchronization with a selected phase in the cardiac cycle. In some embodiments, the endocardial tissue is observed via an image stream stabilized at a selected phase in the cardiac cycle, and movement and/or activation of an ablation (or other) tool is applied at the same selected phase in the course of a plurality of cardiac cycles.

[0605] Percutaneous myocardial revascularization, such as via creating holes in the heart muscle in a desired pattern and by means of an energy delivery or mechanical penetration tool. In some embodiments, movement of the tool is performed in synchronization with a selected phase in the cardiac cycle. In some embodiments, the tool is actuated (such as to deliver energy or drill a hole) in synchronization with a selected phase in the cardiac cycle. In some embodiments, the endocardial tissue is observed via an image stream stabilized at a selected phase in the cardiac cycle, and movement and/or activation of the tool is applied at the same selected phase in the course of a plurality of cardiac cycles.

[0606] Delivering any material or substance, such as, for example, gene therapy or stem cells to specific locations in the heart muscle. In some embodiments, the current invention facilitates the injection of a substance into the heart muscle in a desired pattern, such as a series of points spread across a surface area. In some embodiments, movement of the tool is performed in synchronization with a selected phase in the cardiac cycle. In some embodiments, delivery of the substance is performed in synchronization with a selected phase in the cardiac cycle. In some embodiments, the endocardial tissue is observed via an image stream stabilized at a selected phase in the cardiac cycle, and movement of the tool and/or delivery of the substance is applied at the same selected phase in the course of a plurality of cardiac cycles.

[0607] Suturing tissue in a cyclically-moving organ, such as in a bypass or a valve or a graft. In some embodiments, movement of the suturing tool is performed in synchronization with a selected phase in the cardiac cycle. In some embodiments, suturing is performed in synchronization with a selected phase in the cardiac cycle. In some embodiments, the endocardial tissue is observed via an image stream stabilized at a selected phase in the cardiac cycle, and movement of the tool and/or suturing is applied at the same selected phase in the course of a plurality of cardiac cycles.

[0608] Trans Thoracic Needle Aspiration (TTNA), such as when a cyclically-moving lesion within the lungs needs to be biopsied (and while avoiding mistaken penetration of life-critical organs). With embodiments of the current invention, an aspiration needle is led to, and positioned at, a desired anatomical location in the thorax (such as a lung lesion) while both the tool and thoracic anatomy are viewed in an image stream (such as CT images) that is typically stabilized at a selected same phase in the respiratory and/or cardiac cycle. Next, aspiration is performed at the desired anatomical location in a selected phase of the cardiac and/or respiratory cycle. The selected phase is typically the same as the phase selected for the stabilization of the image stream.

[0609] Trans Bronchial Needle Aspiration (TBNA) such as when a cyclically-moving lesion within the lungs needs to be biopsied (and while avoiding mistaken penetration of life-critical organs).

[0610] Neural stimulation in the brain with its activation gated with the EEG signal.

[0611] Attaching or placing a tool at a desired location, on or within a cyclically-moving organ.

[0612] Moving or directing a tool to a desired location, on or within a cyclically-moving organ.

[0613] Or any combination thereof.

[0614] It will be appreciated by persons skilled in the art that the present invention is not limited to what has been particularly shown and described hereinabove. Rather, the scope of the present invention includes both combinations and subcombinations of the various features described hereinabove, as well as variations and modifications thereof that are not in the prior art, which would occur to persons skilled in the art upon reading the foregoing description.

1. (canceled)

2. A method for use with a portion of a body of a subject that moves as a result of cyclic activity of a body system of the subject, the method comprising:

sensing a phase of the cyclic activity;

in a first cycle of the cyclic activity, in response to sensing that the cyclic activity is at a first given phase thereof, actuating a therapeutic tool to apply a treatment to the portion of the subject's body by applying energy to the portion of the subject's body;

following the given phase in the first cycle and prior to an occurrence of the given phase in a subsequent cycle of the cyclic activity, inhibiting the tool from applying energy to the portion of the subject's body; and

in a second cycle of the cyclic activity, subsequent to the inhibiting of the application of energy to the portion of the subject's body, and in response to sensing that the second cycle of the cyclic activity is at the given phase thereof, actuating the tool to apply energy to the portion of the subject's body.

3. The method according to claim 2, further comprising: in a third cycle that is between the first and second cycles, in response to sensing that the cyclic activity is at the given phase thereof, moving at least a portion of the tool, and

following the given phase in the third cycle, and prior to an occurrence of the given phase in a further subsequent cycle of the cyclic activity, inhibiting the portion of the tool from moving.

4. The method according to claim 2, further comprising: while actuating the tool to apply energy to the portion of the subject's body, acquiring a plurality of images of the tool inside the portion of the subject's body;

generating a stabilized image stream by stabilizing the images with respect to the given phase of the cyclic activity; and

displaying the stabilized image stream.

5. The method according to claim 2,

wherein the tool includes a myocardial revascularization tool configured to sequentially apply a revascularization treatment to respective treatment sites within the portion of the subject's body,

wherein actuating the tool to apply energy to the portion of the subject's body comprises actuating the tool to apply a revascularization treatment to a treatment site,

the method further comprising between successive applications of energy to the portion of the subject's body, moving at least a portion of the revascularization tool toward successive treatment sites.

6. The method according to claim 5, wherein moving at least a portion of the revascularization tool toward successive treatment sites comprises moving the at least the portion of the tool such as to create a defined pattern of treatment sites.

7. The method according to claim 2, wherein the tool includes an ablation tool configured to sequentially ablate respective ablation sites within the portion of the subject's body, wherein actuating the tool to apply energy to the portion of the subject's body comprises actuating the tool to ablate an ablation site, and the method further comprising between successive applications of energy to the portion of the subject's body, moving at least a portion of the ablation tool toward successive ablation sites.

8. The method according to claim 7, wherein moving the at least the portion of the tool comprises moving the at least the portion of the tool such as to create a defined pattern of ablation sites.

9. The method according to claim 7, wherein moving the at least the portion of the tool comprises moving the at least the portion of the tool such as to apply a Maze procedure to the ablation sites.

10. The method according to claim 7, wherein actuating the tool to ablate the ablation site comprises actuating the tool to ablate the ablation site using an ablation technique selected from the group consisting of: laser ablation, electrocautery, RF ablation, cryogenic ablation, and ultrasound ablation.

11. The method according to claim 7, wherein moving the at least the portion of the tool comprises moving the at least the portion of the tool such as to apply a pulmonary vein isolation technique to a heart of the subject.

12. Apparatus for use with a portion of a body of a subject that moves as a result of cyclic activity of a body system of the subject, the apparatus comprising:
 a sensor for sensing a phase of the cyclic activity;
 a therapeutic medical tool configured to apply a treatment to the portion of the subject's by body by applying energy to the portion of the subject's body; and
 an actuator configured:
 in a first cycle of the cyclic activity in response to the sensor sensing that the cyclic activity is at a first given phase thereof, to actuate the tool to apply energy to the portion of the subject's body,
 following the given phase in the first cycle and prior to an occurrence of the given phase in a subsequent cycle of the cyclic activity, to inhibit the tool from applying energy to the portion of the subject's body, and
 in a second cycle of the cyclic activity, subsequent to the inhibiting of the tool from applying energy to the portion of the subject's body, and in response to the sensor sensing that the second cycle of the cyclic activity is at the given phase thereof, to actuate the tool to apply energy to the portion of the subject's body.

13. The apparatus according to claim 12, wherein the actuator is configured:

in a third cycle that is between the first and second cycles, in response to sensing that the cyclic activity is at the given phase thereof, to move at least a portion of the tool, and
 following the given phase in the third cycle, and prior to an occurrence of the given phase in a further subsequent cycle of the cyclic activity, to inhibit the portion of the tool from moving.

14. The apparatus according to claim 12, further comprising:
 an imaging device configured to acquire a plurality of images of the tool inside the portion of the subject's body; and
 a display,
 wherein the actuator is configured to generate a stabilized image stream by stabilizing the images with respect to the given phase of the cyclic activity; and to drive the display to display the stabilized image stream.

15. The apparatus according to claim 12, wherein the tool comprises a myocardial revascularization tool configured to sequentially apply a revascularization treatment to respective treatment sites within the portion of the subject's body, and wherein the actuator is configured to:
 actuate the tool to apply a revascularization treatment to a treatment site by actuating the tool to apply energy to the portion of the subject's body, and
 between successive applications of energy to the portion of the subject's body, to move at least a portion of the revascularization tool toward successive treatment sites.

16. The apparatus according to claim 15, wherein the actuator is configured to move the tool such as to create a defined pattern of treatment sites.

17. The apparatus according to claim 12, wherein the tool comprises an ablation tool configured to sequentially ablate respective ablation sites within the portion of the subject's body, and wherein the actuator is configured to:
 actuate the tool to ablate an ablation site by actuating the tool to apply energy to the portion of the subject's body, and
 between successive applications of energy to the portion of the subject's body, to move at least a portion of the ablation tool toward successive ablation sites.

18. The apparatus according to claim 17, wherein the ablation tool is configured to ablate the ablation sites using an ablation technique selected from the group consisting of: laser ablation, electrocautery, RF ablation, cryogenic ablation, and ultrasound ablation.

19. The apparatus according to claim 17, wherein the actuator is configured to move the at least the portion of the tool by moving the at least the portion of the tool to such as create a defined pattern of ablation sites.

20. The apparatus according to claim 17, wherein the actuator is configured to apply a Maze procedure to the ablation sites by moving the at least the portion of the tool toward successive ablation sites.

21. The apparatus according to claim 17, wherein the ablation tool is configured to apply a pulmonary vein isolation technique to a heart of the subject by applying energy to successive ablation sites.

* * * * *