

(19)



(11)

EP 4 245 950 A1

(12)

EUROPEAN PATENT APPLICATION

(43) Date of publication:
20.09.2023 Bulletin 2023/38

(51) International Patent Classification (IPC):
E05B 9/08 ^(2006.01) **E05B 9/02** ^(2006.01)
E05B 15/02 ^(2006.01)

(21) Application number: **22162703.7**

(52) Cooperative Patent Classification (CPC):
E05B 9/02; E05B 9/08; E05B 15/0205;
E05B 65/0007

(22) Date of filing: **17.03.2022**

(84) Designated Contracting States:
AL AT BE BG CH CY CZ DE DK EE ES FI FR GB GR HR HU IE IS IT LI LT LU LV MC MK MT NL NO PL PT RO RS SE SI SK SM TR
Designated Extension States:
BA ME
Designated Validation States:
KH MA MD TN

(71) Applicant: **Locinox**
8790 Waregem (BE)

(72) Inventor: **TALPE, Joseph**
8551 Heestert-Zwevegem (BE)

(74) Representative: **Gevers Patents**
Intellectual Property House
Holidaystraat 5
1831 Diegem (BE)

(54) **DOOR LOCK FIXTURE MOUNTED ONTO A TUBULAR MEMBER**

(57) A system comprising a tubular member and a door lock fixture fixed thereto by a top bolt (12) and a bottom bolt (13). The tubular member has a wall with an elongated rectangular slot therein. The door lock fixture comprises a faceplate (1) and a fixture body (5) configured to be mounted with its fixture body through the elongated rectangular slot with the faceplate engaging an outer surface of said wall. The faceplate comprises a top opening through which said top bolt extends and a bottom opening through which said bottom bolt extends. The elongated rectangular slot comprises a top notch and a bottom notch, said top bolt extending at least partially through said top notch and said bottom bolt extending at least partially through said bottom notch. The notches aid in positioning the door lock fixture with respect to the support member.

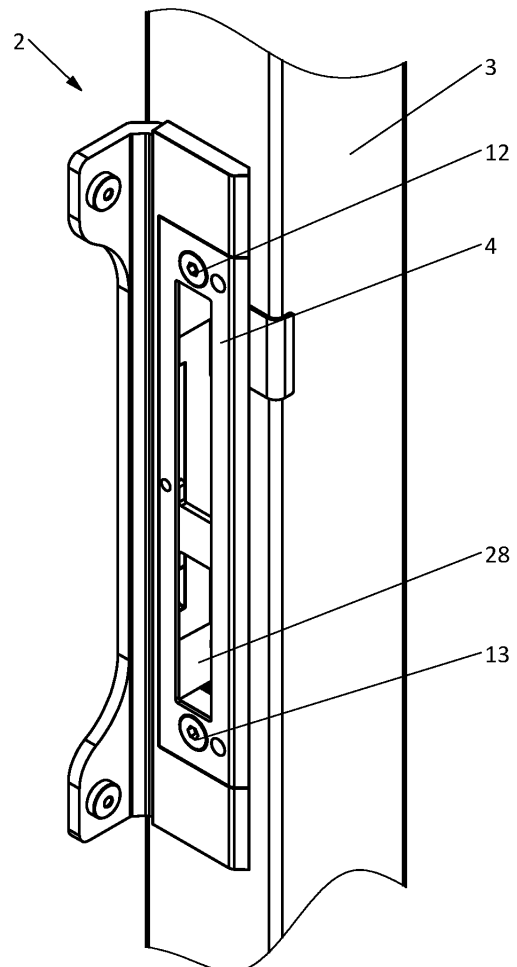

Fig. 2

EP 4 245 950 A1

Description

Technical field

[0001] The present invention relates to a system comprising a tubular member and a door lock fixture fixed thereto. The door lock fixture comprises a faceplate and a fixture body and is mounted with its fixture body through an elongated rectangular slot in a wall portion of the tubular member, with the faceplate of the fixture being configured to engage an outer surface of said wall portion of the tubular member and to be fixed to said wall portion by means two bolts which are applied through an opening in said faceplate.

Background art

[0002] The door lock fixture is in particular a mortice lock or a keep for a door lock. The word "door" is used in the present specification to embrace all kinds of closure members such as doors, having a full door panel, and gates. The door can either be a hinged or a sliding closure member.

[0003] EP 3 153 645 discloses a system comprising a tubular member and a door lock fixture fixed thereto by a top bolt and a bottom bolt, the tubular member having a wall with an elongated rectangular slot therein, the elongated rectangular slot extending in a longitudinal direction and having an top short side and a bottom short side, the door lock fixture comprising a faceplate and a fixture body, the door lock fixture being configured to be mounted with its fixture body through said elongated rectangular slot with the faceplate engaging an outer surface of said wall, the faceplate comprising a top opening through which said top bolt extends and a bottom opening through which said bottom bolt extends.

[0004] EP 3 153 645 further discloses that the fixture body includes moveable (e.g. slideable or pivotable) clamping levers which, when retracted, allow inserting the fixture body through the rectangular elongated slot, and, when extended, engage an inner surface of the tubular member thereby clamping a wall portion of the tubular member between the clamping lever and the faceplate. Each clamping lever comprises a threaded opening which, when the clamping levers are extended, axially aligns with a respective one of the top/bottom opening in the faceplate. The top/bottom bolt is fastened through a threaded opening in a respective clamping lever.

[0005] A downside of this known system is the positional leeway between the door lock fixture and the tubular member both in the longitudinal direction of the support member and in the width direction of the elongated rectangular slot.

Disclosure of the invention

[0006] It is an object of the present invention to provide a system comprising a tubular member and a door lock

fixture fixed thereto which addresses the above mentioned downsides.

[0007] To this end, the system according to the invention is characterised in that the elongated rectangular slot comprises a top notch at the top short side and a bottom notch at the bottom short side, the notches extending away from one another, said top bolt extending at least partially through said top notch and said bottom bolt extending at least partially through said bottom notch, the system further comprising a top nut and a bottom nut for fastening a respective bolt.

[0008] Providing the notches through which the bolts extend cause a desired positioning of the door lock fixture with respect to the support member. More specifically, as each bolt partially extends through a respective notch, both the height (i.e. longitudinal direction) and the width position of the bolts with respect to the support member is fixed. Likewise, since each bolt extends through a respective opening in the faceplate, the height/width position of the faceplate (i.e. the door lock fixture) is fixed with respect to the support member. The leeway possible with the known system is thus avoided.

[0009] Moreover, this advantage is obtained without, as suggested in EP 3 153 645, having to create separate openings in the support member. In other words, the required opening in the support member (i.e. the elongated rectangular slot with notches) can be manufactured in a single step (e.g. by cutting, laser cutting, milling, etc.).

[0010] In an embodiment of the present invention, each nut is moveably mounted onto the fixture body between a retracted position in which the fixture body can be inserted through said elongated rectangular slot into the tubular member, and an extended position in which the nut at least partially engages an inner surface of said wall to clamp said wall between the faceplate and the nut.

[0011] In this way, the nuts are invisible from the outside of the system thereby improving anti-tamper properties of the system. Furthermore, each bolt can be tightened strongly so that the wall of the tubular member is clamped strongly and reliably between the faceplate and the nut irrespective of the thickness of the wall of the tubular member.

[0012] In a first alternative embodiment of the present invention, the nuts are formed as a threaded opening in a support, each support being moveably mounted on the fixture body between a retracted position in which the fixture body can be inserted through said elongated rectangular slot into the tubular member and an extended position in which the nut is axially aligned with a respective one of the top opening and bottom opening. The supports may be manually moveable from their retracted position to their extended position or they may be spring biased towards their extended position with a latch being provided for each support to hold its nut in its retracted position. The supports may be slideable or pivotable between their retracted position and their extended position.

[0013] Such supports are disclosed in EP 3 153 645 and have various advantages. For example, such sup-

ports are suitable for varying wall thicknesses. Moreover, such supports do not hamper the insertion of the fixture body into the tubular member since it is held in its retracted position when the fixture body is inserted into the tubular member. A pivotable support is advantageous as the support can simply pivot within the tubular member from its retracted to its extended position until it engages the inner surface of the wall of the tubular member. A spring-biased support ensures that the support has only to be released to be brought automatically by the spring into its extended position. A corresponding latch can be actuated to release the support. Actuation of the latch can for example be done through the hole for the bolt in the faceplate. Alternatively, the door lock fixture may comprise a removable locking element which holds the support in its retracted position. By simply removing this locking element, the support is released and moves under the action of said spring in the tubular member until it projects behind the inner surface of the wall of the tubular member. In this position, the bolt can be inserted through said opening in the faceplate in the fixture and can be screwed in the screw threaded hole in the clamping lever to clamp the wall of the tubular member strongly between the faceplate of the fixture and the nut formed in the support.

[0014] In a second alternative embodiment of the present invention, the nuts are irrotatably mounted on a support arm, each support arm being slideably mounted on the fixture body between a retracted position in which the fixture body can be inserted through said elongated rectangular slot into the tubular member and an extended position in which the nut is axially aligned with a respective one of the top opening and bottom opening, each nut being slideably mounted on a respective support arm along a transverse direction which is substantially perpendicular to the longitudinal direction and is preferably further perpendicular to the faceplate.

[0015] This alternative embodiment is also suited for varying wall thicknesses. Furthermore, by having a separate nut and support, the risk of damaging the support is reduced when tensioning the bolt when compared to the first alternative embodiment where the nut is formed as an opening in the support.

[0016] In an embodiment of the present invention, each bolt has a bolt head and a threaded part extending in a first direction, the bolt head defining a hypothetical circumscribed cylinder extending in said first direction, wherein a part of said wall adjacent said notches is located inside a respective hypothetical cylinder.

[0017] In this embodiment a part of the tubular member is located directly underneath the bolt head. In other words, the tubular support is partially positioned directly between the bolt head and the nut which optimizes force transfer between the door lock fixture and the tubular member.

[0018] In an embodiment of the present invention, each notch comprises a substantially semi-circular part, said part in particular having a diameter between 5 mm and

10 mm and more particularly between 6 mm and 7 mm.

[0019] In an embodiment of the present invention, a leeway between each notch and its respective bolt is at most 1 mm, particularly at most 0,5 mm.

5 **[0020]** In an embodiment of the present invention, each notch has an opening width which is measured along a line contiguous with its respective short side, the opening width being at most 50%, particularly at most 40%, and more particularly at most 30%, of a width of the elongated rectangular slot.

10 **[0021]** In an embodiment of the present invention, the elongated rectangular slot has a width and a height, the height being at least 4 times, particularly at least 6 times, and more particularly at least 7 times, larger than the width, the width preferably being between 10 and 35 mm, particularly between 15 and 30 mm, and more particularly between 20 and 25 mm.

15 **[0022]** The various dimensions of the elongated rectangular slot are mainly determined in view of the dimensions of the lock fixture. Furthermore, the notch dimensions are mainly determined depending on the bolt diameter with higher diameter bolts typically leading to a stronger, albeit more expensive, connection.

20 **[0023]** In an embodiment of the present invention, the notches are aligned with one another in the longitudinal direction. This leads to a symmetric design which reduces manufacturing and/or assembly errors.

Brief description of the drawings

30 **[0024]** Other particularities and advantages of the invention will become apparent from the following description of some particular embodiments of a mortice lock and of a keep according to the present invention. The reference numerals used in this description relate to the annexed drawing.

Figure 1 shows a perspective view of a mortice lock mounted on a tubular member.

40 Figure 2 shows a perspective view of a morticed lock keep mounted on a tubular member.

Figure 3 shows a front view of the tubular member of figures 1 and 2.

Figure 4 shows a detail of figure 3.

45 Figure 5 shows a perspective view of a cooperating mortice lock and keeper mounted on two tubular members as part of a closure system.

Figure 6 shows a partial longitudinal cross-section through the cooperating mortice lock and keeper of figure 5. The lock has not been fully shown in cross-section to avoid irrelevant details.

Figure 7 shows a detail of figure 6.

Description of the invention

55 **[0025]** The present invention will be described with respect to particular embodiments and with reference to certain drawings but the invention is not limited thereto

but only by the claims. The drawings described are only schematic and are non-limiting. In the drawings, the size of some of the elements may be exaggerated and not drawn on scale for illustrative purposes. The dimensions and the relative dimensions do not necessarily correspond to actual reductions to practice of the invention.

[0026] Furthermore, the terms first, second, third and the like in the description and in the claims, are used for distinguishing between similar elements and not necessarily for describing a sequential or chronological order. The terms are interchangeable under appropriate circumstances and the embodiments of the invention can operate in other sequences than described or illustrated herein.

[0027] Moreover, the terms top, bottom, over, under and the like in the description and the claims are used for descriptive purposes. The terms so used are interchangeable under appropriate circumstances and the embodiments of the invention described herein can operate in other orientations than described or illustrated herein.

[0028] Furthermore, the various embodiments, although referred to as "preferred" are to be construed as exemplary manners in which the invention may be implemented rather than as limiting the scope of the invention.

[0029] The present invention generally relates to a system comprising a tubular member 3 and a door lock fixture mounted thereon. In the embodiment of figure 1, the door lock fixture is a mortice lock 1 to be inserted into a closure member, in particular in a hollow tubular member 3 thereof. In the embodiment of figure 2, the door lock fixture is a morticed lock keep 2 which comprises a body portion that is inserted in the support onto which it is mounted. The support is generally formed by a hollow tubular member 3 and can either be a fixed post or a leaf of a double door or gate.

[0030] In general, the door lock fixture (i.e. the mortice lock 1 or the morticed lock keep 2) comprises a faceplate 4 and a fixture body 5. The tubular member 3 is generally part of a gate, as illustrated in the figures, or of a door or any other type of hinged closure member and generally comprises a rectangular elongated slot 6 in a wall portion 7. The rectangular elongated slot 6 has a top short side 8, a bottom short side 9, and two long sides 10 which extend in a longitudinal direction 11 (which is also the direction along which the tubular body 3 extends). The fixture body 5 is designed to be inserted through the rectangular elongated slot 6 with the faceplate 4 engaging an outer side of the wall portion 7.

[0031] In order to attach the door lock fixture to the tubular member 3, use is made of a top bolt 12 and a bottom bolt 13 which are placed through a corresponding top/bottom opening in the faceplate 4. Each bolt 12, 13 further at least partially extends through a corresponding one of a top notch 14 and a bottom notch 15 which are provided in a respective top/bottom short side 8, 9. This ensure that the faceplate 4 (and thus the door lock fixture)

are correctly aligned with the rectangular elongated slot 6. Each bolt 12, 13 is bolted into a corresponding one of a top nut 16 and a bottom nut 17. In the illustrated embodiments (as best shown in figures 6 and 7), as described in more detail below, the nuts 16, 17 are located inside the tubular member 3. However, in other embodiments, the bolts may fully extend through the tubular member with the nuts being provided on the rear side thereof.

[0032] As illustrated in figures 3 and 4, the elongated rectangular slot 6 has a width W and a height H . The height H is at least 4 times, particularly at least 6 times, and more particularly at least 7 times, larger than the width W . The width is between 10 and 35 mm, particularly between 15 and 30 mm, and more particularly between 20 and 25 mm, with the width W being about 22 mm in the illustrated embodiment. These dimensions are mainly determined in view of the dimensions of the lock body.

[0033] In the illustrated embodiment as best shown in figure 4, each notch 14, 15 comprises a semi-circular part 20 and two straight parts 21. The semi-circular part 20 in particular having a diameter between 5 mm and 10 mm and more particularly between 6 mm and 7 mm. These dimension of this semi-circular part 20 is mainly determined depending on the bolt diameter and a maximum leeway between the bolt diameter and the semi-circular part 20 is 1 mm and particularly 0,5 mm. The two straight parts 21 in the illustrated embodiment each have a length L of 2 mm, but other lengths are possible. The main reason for these straight parts 21 is to avoid the bolts 12, 13 centre-lines to coincide with the top/bottom short side 8, 9. In view of manufacturing tolerances, this could lead to bolts 12, 13 not being correctly positioned in their respective notch 14, 15.

[0034] Each notch 14, 15 has an opening width W_o which measured along a line contiguous with its respective short side 8, 9. The opening width W_o is at most 50%, particularly at most 40%, and more particularly at most 30%, of a width W of the elongated rectangular slot 6. This dimension is mainly determined depending on the bolt diameter and is preferably equal to the diameter of the semi-circular part 20. In the illustrated embodiments, the notches 14, 15 are aligned in the longitudinal direction 11 leading to a symmetric design.

[0035] Details on the specific fixation of the door lock fixture to the tubular support 3 will be described with reference to figures 5 to 7 which illustrate a double wing gate having a mortice lock 1 in a tubular member of a first gate wing 22 and a morticed lock keep 2 in a tubular member of a second gate wing 23. It will be readily appreciated that the second gate wing may also be a fixed support.

[0036] The lock 1 may have a locking mechanism of any type and comprises a faceplate 4 and a lock body 5. The lock 1 may comprise a latch bolt 24 which is operated by means of handles 25, a deadbolt 26 which is operated by means of a key in particular through the intermediary of a lock cylinder 27 (for example a single-barrel euro-

profile cylinder), or it may comprise a combination of a latch bolt 24 and a deadbolt 26 as in the embodiments illustrated in the drawings. Usually the latch bolt 24 and the deadbolt 26 are slideably mounted in the lock 1 to slide between a retracted and an extended position. In the embodiments illustrated in the drawings, the deadbolt 26 is however hook-shaped and pivots in the lock 1 between its extended and its retracted positions. The lock illustrated in figure 6 is in particular a lock as disclosed in EP 2 186 974 and EP 3 153 645 and further details about this lock can be found therein.

[0037] The morticed lock keep 2 comprises a faceplate 4 and a partially hollow body 5. The faceplate 4 comprises an elongated opening 28 and the partially hollow body 5 forms a corresponding elongated slot 29 in which the latch bolt 24 and/or the deadbolt 26 are received as shown in figure 6. The morticed lock keep 2 illustrated in the figures is in particular a morticed lock keep as disclosed in EP 3 153 645 and further details about this morticed lock keep can be found therein.

[0038] The fixture body 5 of the morticed lock keep 2 is provided with two support arms 30 which are (manually) slideably mounted onto the fixture body 5 along the longitudinal direction 11 between a retracted position in which the fixture body 5 can be inserted through the rectangular elongated slot 6 into the tubular member 3 and an extended position (shown in figures 6 and 7). On each support arm 30, there is provided a nut 16, 17 which is irrotatably and slideably mounted on the respective support arm 30 along a transverse direction 31 (indicated in figure 6) between a rest position and an engaging position (shown in figure 6). Each nut 16, 17 comprises a threaded opening configured to receive a bolt 12, 13 used to mount the morticed lock keep 10 on the tubular member 3. In the illustrated embodiment, the nut 16, 17 is irrotatable with respect to the support arm 30 due to its square (in general non-circular) outer shape.

[0039] Other details and advantages of the support arms 30 with slideable nuts 16, 17 are described in a patent application titled "Door lock fixture arranged to be mounted onto a tubular member" filed on the same day by the same applicant as the present application and are incorporated herein by reference.

[0040] The fixture body 5 of the mortice lock 1 is provided with two supports 32 that are moveable (e.g. slideable or pivotable) between a retracted position in which the fixture body 5 can be inserted into the elongated opening 6 and an extended position in which each support 32 engages an inner surface of the tubular member 3. Each support 32 is provided with a threaded opening which forms a respective one of the nuts 16, 17. In the illustrated embodiments, the supports 32 are pivotable and spring-biased due to a spring member 33 and latches 34 are provided to maintain the supports 32 in their retracted position. The supports 32 are identical to those described in EP 3 153 645 A1 which is incorporated herein by reference.

[0041] Irrespective of the fixation system used, each

bolt has a bolt head and a threaded part extending in direction 31. The bolt head defines a hypothetical circumscribed cylinder extending in direction 31, wherein a part of said wall 7 adjacent said notches 14, 15 is located inside a respective hypothetical cylinder.

[0042] It will be readily appreciated that the fixation systems described above for the mortice lock 1 and the morticed lock keep 2 are interchangeable and still others may be used in accordance with the present invention related to the provision of notches 14, 15 for the alignment of the fixation bolts 12, 13.

[0043] Although aspects of the present disclosure have been described with respect to specific embodiments, it will be readily appreciated that these aspects may be implemented in other forms within the scope of the invention as defined by the claims.

Claims

1. A system comprising a tubular member (3) and a door lock fixture (1, 2) fixed thereto by a top bolt (12) and a bottom bolt (13), the tubular member having a wall (7) with an elongated rectangular slot (6) therein, the elongated rectangular slot extending in a longitudinal direction (11) and having an top short side (8) and a bottom short side (9), the door lock fixture comprising a faceplate (4) and a fixture body (5), the door lock fixture being configured to be mounted with its fixture body through said elongated rectangular slot with the faceplate engaging an outer surface of said wall, the faceplate comprising a top opening through which said top bolt extends and a bottom opening through which said bottom bolt extends, **characterized in that** the elongated rectangular slot comprises a top notch (14) at the top short side and a bottom notch (15) at the bottom short side, the notches extending away from one another, said top bolt extending at least partially through said top notch and said bottom bolt extending at least partially through said bottom notch, the system further comprising a top nut (16) and a bottom nut (17) for fastening a respective bolt.
2. The system according to claim 1, **characterized in that** each nut is moveably mounted onto the fixture body between a retracted position in which the fixture body can be inserted through said elongated rectangular slot into the tubular member, and an extended position in which the nut at least partially engages an inner surface of said wall to clamp said wall between the faceplate and the nut.
3. The system according to claim 2, **characterized in that** the nuts are formed as a threaded opening in a support (32), each support being moveably mounted on the fixture body between a retracted position in which the fixture body can be inserted through said

elongated rectangular slot into the tubular member and an extended position in which the nut is axially aligned with a respective one of the top opening and bottom opening.

4. The system according to claim 3, **characterized in that** the supports are manually moveable from their retracted position to their extended position. 5
5. The system according to claim 3, **characterized in that** the supports are spring biased towards their extended position and a latch (34) is provided for each support to hold its nut in its retracted position. 10
6. The system according to any one of claims 3 to 5, **characterized in that** the supports are slideable between their retracted position and their extended position. 15
7. The system according to any one of claims 3 to 5, **characterized in that** the supports are rotatable between their retracted position and their extended position. 20
8. The system according to claim 2, **characterized in that** the nuts are irrotatably mounted on a support arm (30), each support arm being slideably mounted on the fixture body between a retracted position in which the fixture body can be inserted through said elongated rectangular slot into the tubular member and an extended position in which the nut is axially aligned with a respective one of the top opening and bottom opening, each nut being slideably mounted on a respective support arm along a transverse direction (31) which is substantially perpendicular to the longitudinal direction and is preferably further perpendicular to the faceplate. 25
30
35
9. The system according to any one of the preceding claims, **characterized in that** each bolt has a bolt head and a threaded part extending in a first direction, the bolt head defining a hypothetical circumscribed cylinder extending in said first direction, wherein a part of said wall adjacent said notches is located inside a respective hypothetical cylinder. 40
45
10. The system according to any one of the preceding claims, **characterized in that** each notch comprises a substantially semi-circular part (20), said part in particular having a diameter between 5 mm and 10 mm and more particularly between 6 mm and 7 mm. 50
11. The system according to any one of the preceding claims, **characterized in that** a leeway between each notch and its respective bolt is at most 1 mm, particularly at most 0,5 mm. 55
12. The system according to any one of the preceding

claims, **characterized in that** the notches are aligned with one another in the longitudinal direction.

13. The system according to any one of the preceding claims, **characterized in that** each notch has an opening width W_o which is measured along a line contiguous with its respective short side, the opening width being at most 50%, particularly at most 40%, and more particularly at most 30%, of a width of the elongated rectangular slot.
14. The system according to any one of the preceding claims, **characterised in that** the elongated rectangular slot has a width (W) and a height (H), the height being at least 4 times, particularly at least 6 times, and more particularly at least 7 times, larger than the width, the width preferably being between 10 and 35 mm, particularly between 15 and 30 mm, and more particularly between 20 and 25 mm.
15. The system according to any one of the preceding claims, **characterised in that** the door lock fixture is a keeper for a door lock or a mortice lock.

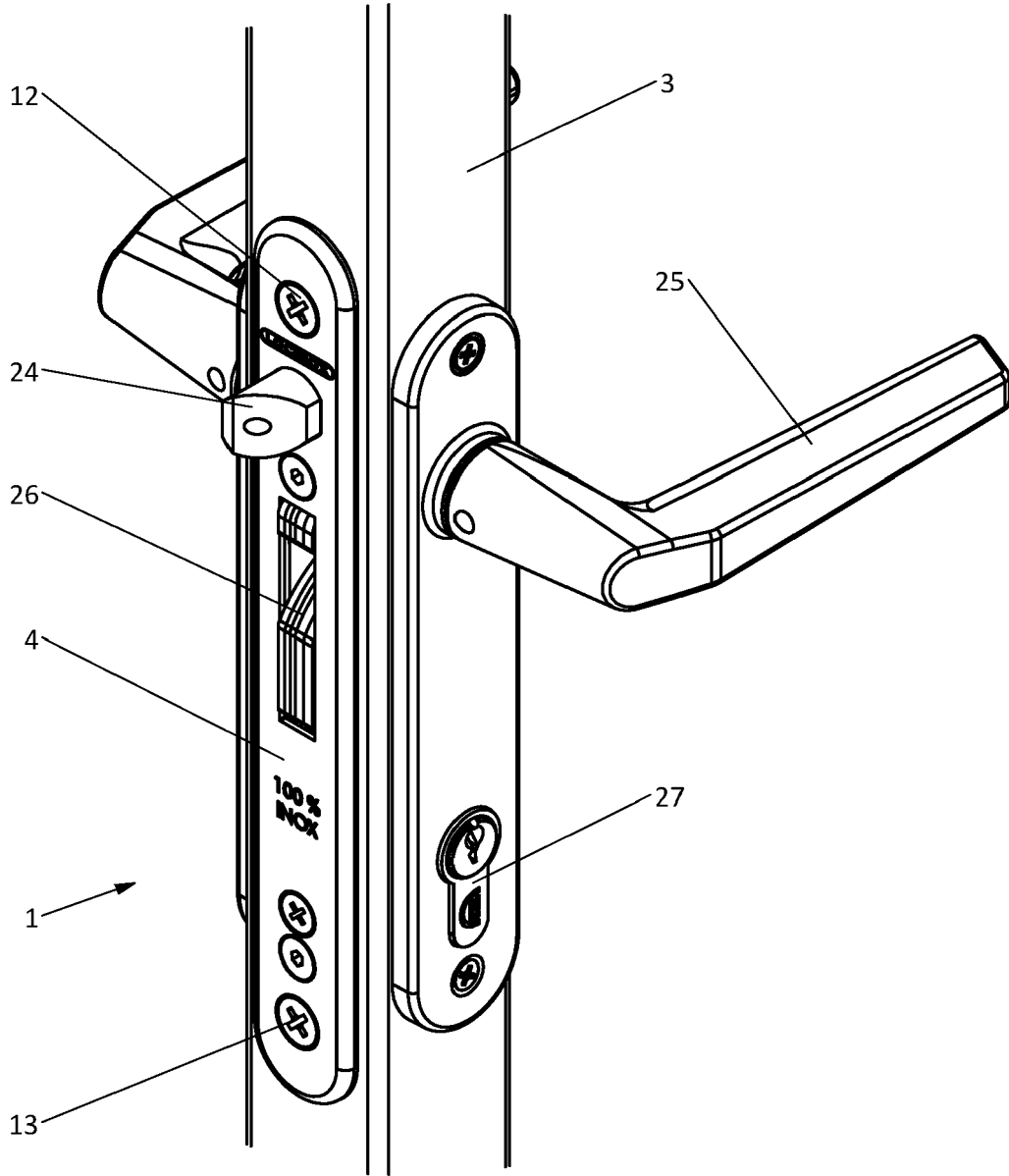

Fig. 1

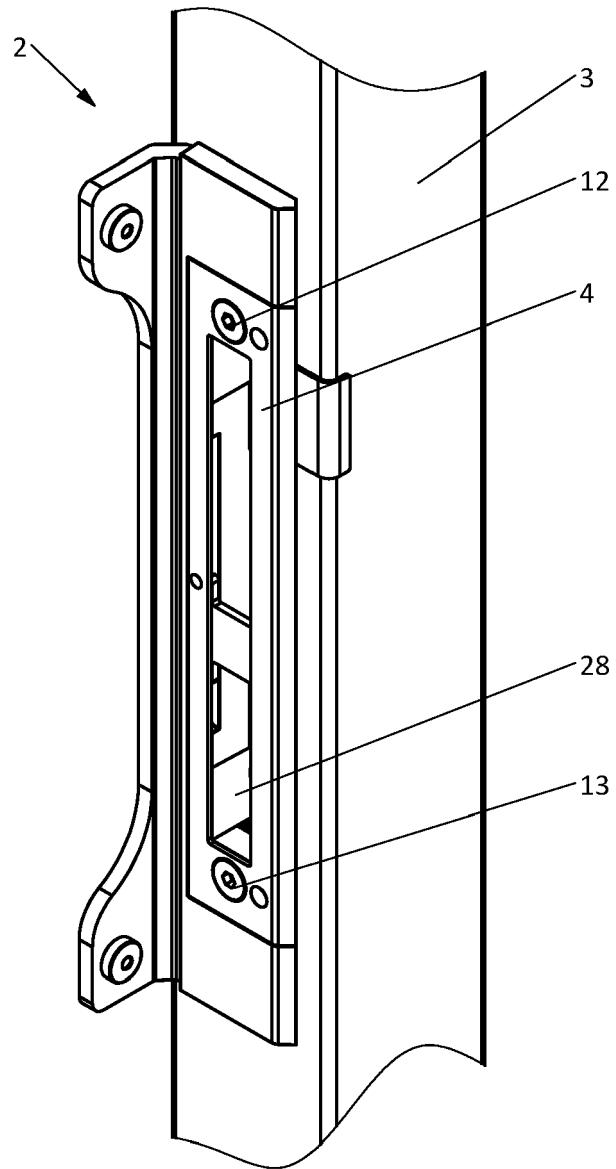

Fig. 2

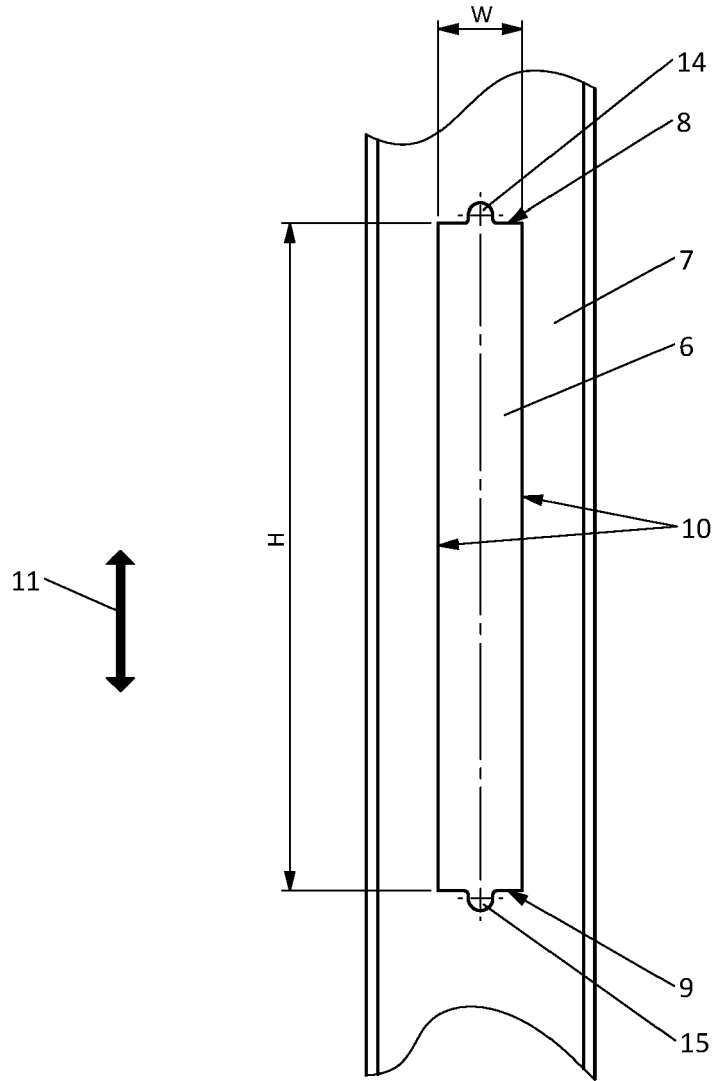

Fig. 3

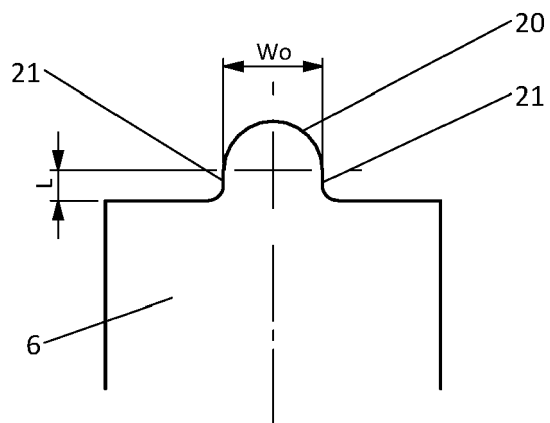

Fig. 4

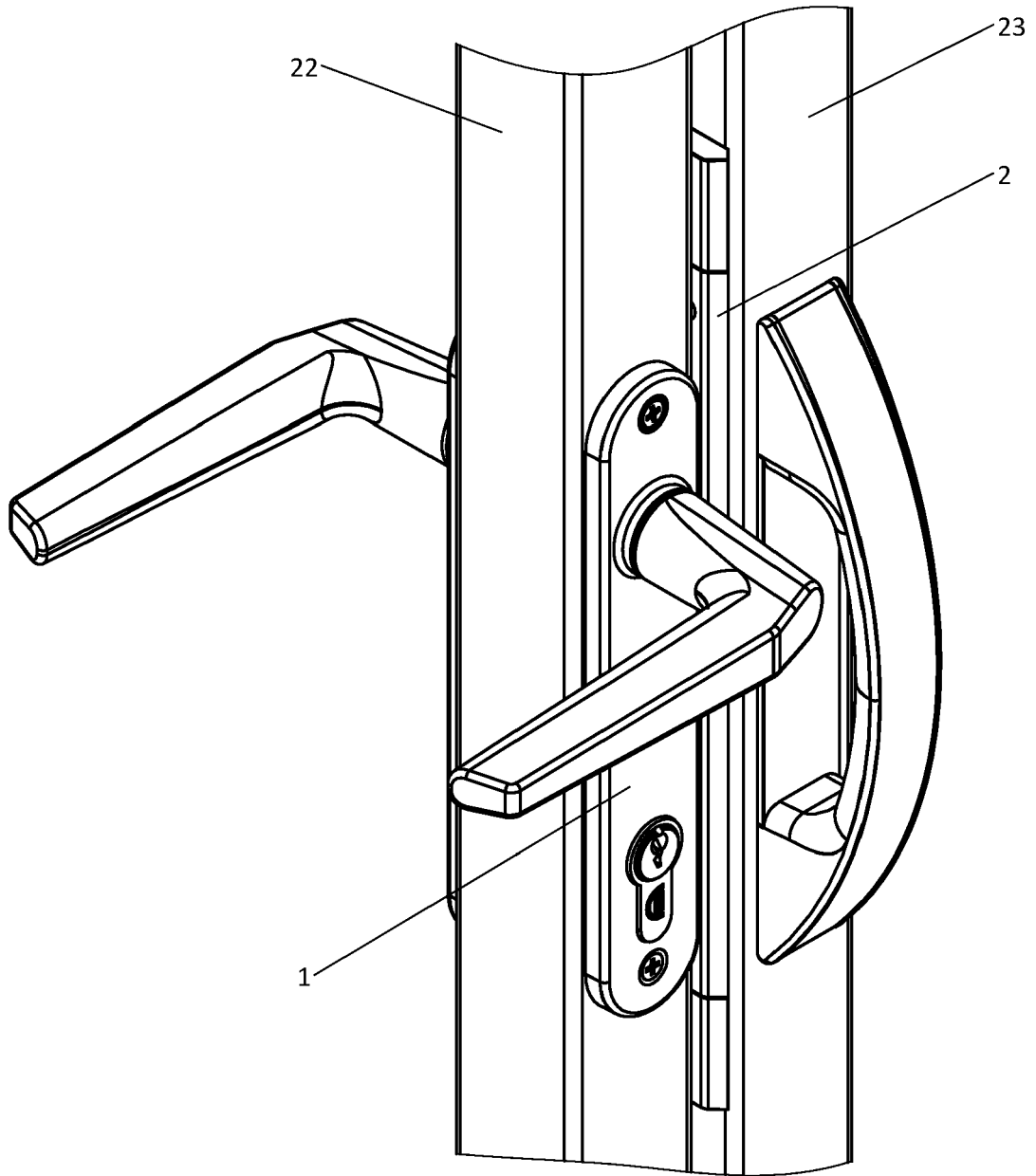

Fig. 5

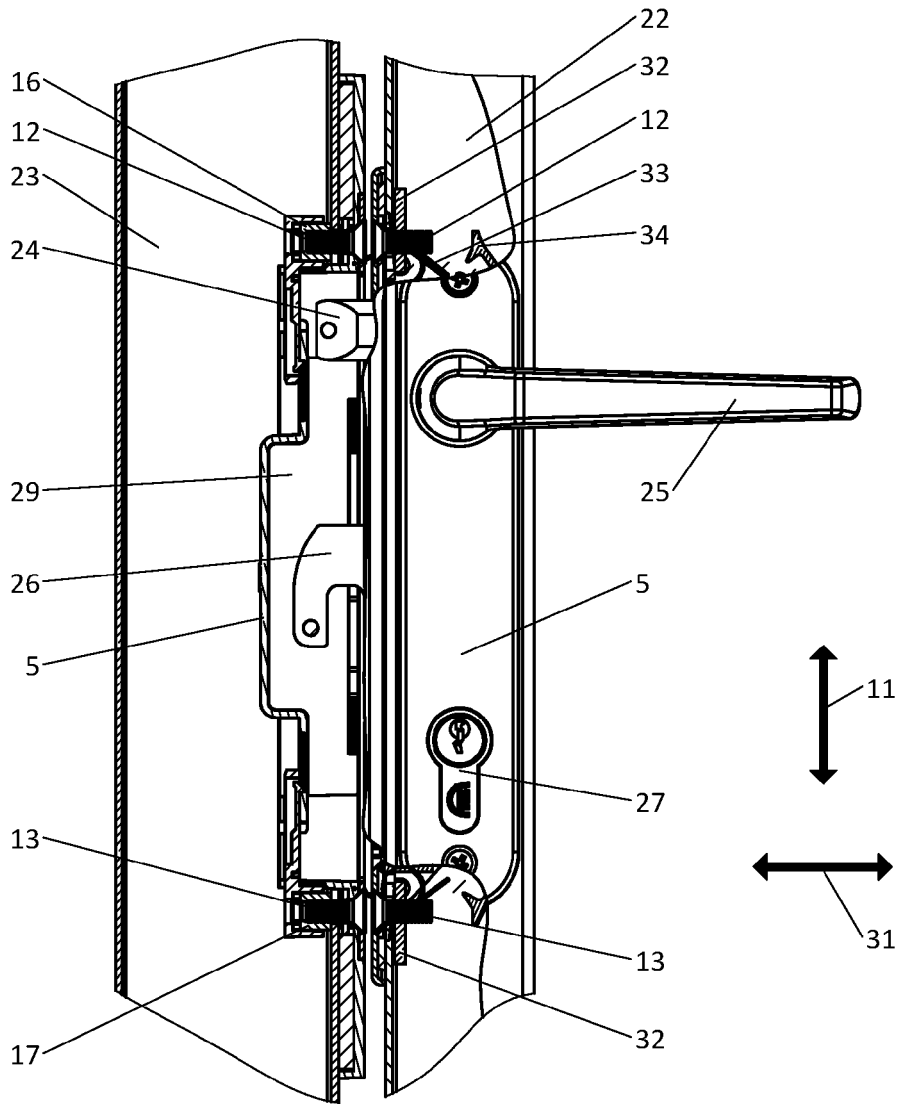

Fig. 6

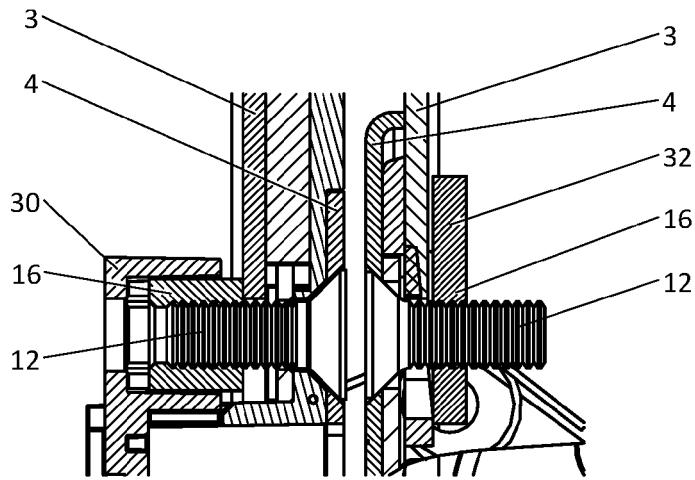

Fig. 7



EUROPEAN SEARCH REPORT

Application Number
EP 22 16 2703

5

10

15

20

25

30

35

40

45

50

55

DOCUMENTS CONSIDERED TO BE RELEVANT			
Category	Citation of document with indication, where appropriate, of relevant passages	Relevant to claim	CLASSIFICATION OF THE APPLICATION (IPC)
A, D	EP 3 153 645 A1 (LOCINOX [BE]) 12 April 2017 (2017-04-12) * the whole document * -----	1-15	INV. E05B9/08 E05B9/02 E05B15/02
A	DE 200 22 248 U1 (BOS GMBH [DE]) 17 May 2001 (2001-05-17) * the whole document * -----	1	
			TECHNICAL FIELDS SEARCHED (IPC)
			E05B
The present search report has been drawn up for all claims			
Place of search The Hague		Date of completion of the search 26 August 2022	Examiner Westin, Kenneth
CATEGORY OF CITED DOCUMENTS X : particularly relevant if taken alone Y : particularly relevant if combined with another document of the same category A : technological background O : non-written disclosure P : intermediate document		T : theory or principle underlying the invention E : earlier patent document, but published on, or after the filing date D : document cited in the application L : document cited for other reasons & : member of the same patent family, corresponding document	

2
EPO FORM 1503 03:82 (P04C01)

**ANNEX TO THE EUROPEAN SEARCH REPORT
ON EUROPEAN PATENT APPLICATION NO.**

EP 22 16 2703

5 This annex lists the patent family members relating to the patent documents cited in the above-mentioned European search report.
The members are as contained in the European Patent Office EDP file on
The European Patent Office is in no way liable for these particulars which are merely given for the purpose of information.

26-08-2022

Patent document cited in search report	Publication date	Patent family member(s)	Publication date
EP 3153645	A1	12-04-2017	BE 1023032 B1
			09-11-2016
			EP 3153645 A1
			12-04-2017
			ES 2763307 T3
			28-05-2020
			PL 3153645 T3
			18-05-2020

DE 20022248	U1	17-05-2001	NONE

EPO FORM P0459

For more details about this annex : see Official Journal of the European Patent Office, No. 12/82

REFERENCES CITED IN THE DESCRIPTION

This list of references cited by the applicant is for the reader's convenience only. It does not form part of the European patent document. Even though great care has been taken in compiling the references, errors or omissions cannot be excluded and the EPO disclaims all liability in this regard.

Patent documents cited in the description

- EP 3153645 A [0003] [0004] [0009] [0013] [0036] [0037]
- EP 2186974 A [0036]
- EP 3153645 A1 [0040]