

No. 815,668.

PATENTED MAR. 20, 1906.

E. E. WITTE.
BAG FASTENER.
APPLICATION FILED MAR. 28, 1904.

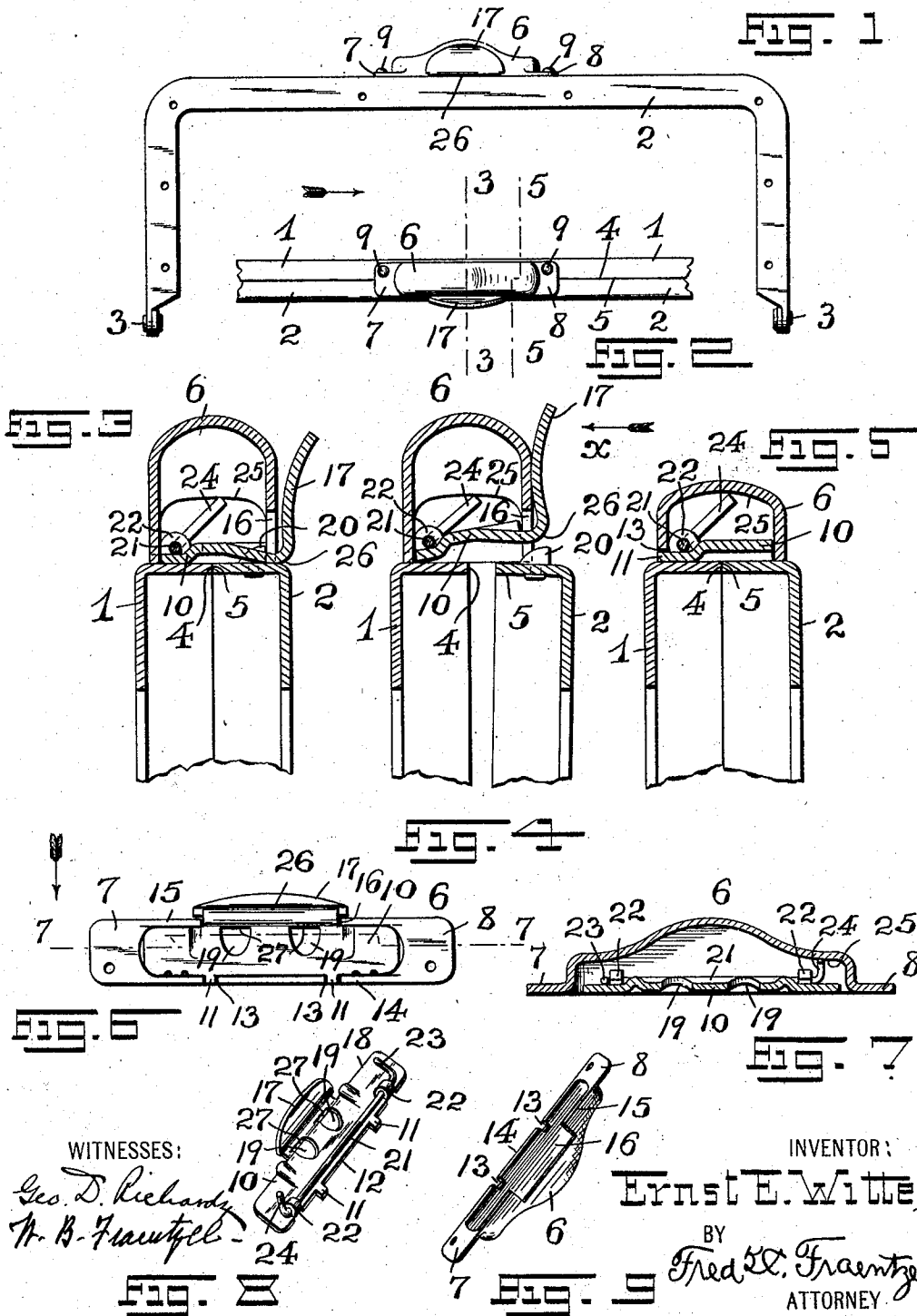

WITNESSES:
Geo. D. Richards
H. B. Fraentzel

INVENTOR:
Ernst E. Witte,
BY
Fred W. Fraentzel,
ATTORNEY

UNITED STATES PATENT OFFICE.

ERNST E. WITTE, OF NEWARK, NEW JERSEY, ASSIGNOR TO THE J. E. MERGOTT COMPANY, A CORPORATION OF NEW JERSEY.

BAG-FASTENER.

No. 815,668.

Specification of Letters Patent.

Patented March 20, 1906.

Application filed March 28, 1904. Serial No. 200,255.

To all whom it may concern:

Be it known that I, ERNST E. WITTE, a citizen of the United States, residing at Newark, in the county of Essex and State of New Jersey, have invented certain new and useful Improvements in Bag-Fasteners; and I do hereby declare the following to be a full, clear, and exact description of the invention, such as will enable others skilled in the art to which it appertains to make and use the same, reference being had to the accompanying drawings, and to numerals of reference marked thereon, which form a part of this specification.

The present invention has reference to improvements in that class of bag-fasteners for bag-frames which are especially adapted to satchels, chatelaine, and other similar bags; and the invention has for its principal object to provide a simple and cheap construction as well as a strongly-made bag-fastener which is more especially adapted for use with the hinged bag-frame sections having their marginal edges in abutting relation when the bag-frame is closed instead of the usual overlapping arrangement.

Other objects of the present invention will be evident from the following detailed description of the device embodying the principles of this invention.

The invention consists in the novel construction of bag-fastener hereinafter set forth and, furthermore, this invention consists in the general arrangements and combination of parts, as well as in the details of the construction of the same, all of which will be fully described in the following specification, and then finally embodied in the clauses of the claim, which are appended to the said specification and form an essential part of the same.

The invention is clearly illustrated in the accompanying drawings, in which—

Figure 1 is a side view of a bag-frame having abutting frame-sections and provided with a bag-fastener embodying the principles of this invention, and Fig. 2 is a top edge view of parts of the two frame-sections and plan or top view of the bag-fastener. Fig. 3 is a transverse vertical section of the two frame-sections and the bag-fastener, said section being taken on line 3 3 in said Fig. 2 and the parts being represented on an enlarged scale and a spring catch-plate of the

said bag-fastener being represented in its normal initial position in holding engagement with a catch or holding device upon one of the said frame-sections; and Fig. 4 is a similar view with the various parts represented in their actuated and disengaged relation with the said catch or holding device to permit of the separable arrangement of the two frame-sections. Fig. 5 is a transverse vertical section of the parts, said section being taken on line 5 5 in said Fig. 2. Fig. 6 is a bottom view of the bag-fastener in its detached relation from the bag-frame sections, and Fig. 7 is a longitudinal vertical section taken on line 7 7 in said Fig. 6 looking in the direction of the arrow in said figure. Fig. 8 is a perspective view of the catch-plate and spring connected therewith, and Fig. 9 is a similar view of the lock-casing with the said catch-plate and spring detached therefrom.

Similar characters of reference are employed in the above-described views to indicate corresponding parts.

Referring now to the several figures of the drawings, the reference characters 1 and 2 indicate a pair of bag-frame sections which are pivotally connected or hinged at their lower end portions, as at 3, and as clearly illustrated in Fig. 1.

The preferred form of bag-frame with which I intend to use the bag-fastener embodying the principles of the present invention is one in which the frame-sections when in their closed relation abut along their marginal edges 4 and 5, as clearly indicated in Figs. 2, 3, 4, and 5 of the drawings; but it will be understood that the bag-fastener may also be used with other forms and constructions of bag-frames, if desired.

The bag fastener or lock consists, essentially, of a suitable shell or casing 6 of any desired ornamentation and configuration, the said shell or casing being made with suitable end portions 7 and 8, provided with suitable fastening means, as 9, by means of which the said shell or casing can be secured upon the upper face of one of the frame-sections, as 1, with a portion of the shell or casing extending beyond the marginal edge 4 of the said frame-section 1, so that the said shell or casing will also be arranged over the top of the other frame-section 2 when the two frame-sections are brought into their closed relation, as clearly indicated in the several fig-

ures of the drawings. Within the said shell or casing 6 I have arranged a suitable catch-plate, which consists, essentially, of a body or plate-like member 10, provided along one of its longitudinal marginal edges, as 12, with ears or lugs 11, which are adapted to be arranged in correspondingly-placed openings 13 in the lower marginal edge 14 of the shell or casing 6. The said shell or casing 6 is made in its oppositely-arranged and longitudinally-extending marginal edge 15 with an opening 16, into and through which extends a suitable finger-piece or lift 17, extending from the opposite marginal edge 18 of the said body or plate-like member 10, the said finger-piece or lift 17 extending in an upward direction directly in front of the said shell or casing 6 and being arranged to provide a suitable closure for the opening 16 in the said shell or casing 6. The said body or plate-like member 10 of the catch-plate is provided with a catch or holding-lug-receiving means, preferably in the form of one or more openings 19, with which a holding device, preferably in the form of holding-lugs 20 upon the frame-section 2, can be brought in holding engagement by forcing the said holding-lugs 20 into the said openings 19, as clearly illustrated in Fig. 3 of the drawings, when the said catch-plate is held in its normal initial and receiving position (indicated in said Fig. 3) by a suitable spring in the manner to be presently described. This spring consists generally of a spring-bar 21, made from wire, the same being clamped in its operative position upon the face of the said body or plate-like member 10 by a pair of clamping or holding lugs 22 and the said spring having at its one end a right-angled member 23, resting upon the face of the said body or plate-like member 10, and said spring being provided at its opposite end with another right-angled member 24, which when the said catch-plate is arranged in its operative position in the chambered shell or casing 6 is brought in forcible engagement with the upper and inner surface or roof 25 of the said shell or casing, and thus causes the said catch-plate in its normal initial position always to rest in the position indicated in Fig. 3 of the drawings, so that when the two frame-sections 1 and 2 are brought into their closed relation the holding lug or lugs upon the frame-section 2 will ride against the lower rounded portion 26 of the finger-piece, thereby slightly raising the latter, and the said lug or lugs 20 then being sprung in holding engagement with the edge-ports 27 of the opening or openings 19 in the catch-plate, in which holding engagement the parts are held by the action of the spring 21 until the catch-plate is raised by exerting pressure against the finger-piece 17 in the direction of the arrow *x* in Fig. 4 of the drawings, when the two frame-sections can once more be brought into their separated rela-

tion, as will be clearly understood and as is illustrated in said Fig. 4.

From the foregoing description of my invention it will be seen that I have devised a very simple and effective construction of bag-fastener in the form of a lock or holding-catch in which there are but few parts, thereby providing a construction which is not likely to be forced out of order.

Having thus described my invention, what I claim is—

1. In a bag-fastener for a frame having hinged frame-sections, said fastener comprising a chambered casing adapted to be secured to one of said frame-sections, and said casing having an opening in its front side and said casing being also provided with openings 13 in its opposite side, a catch-plate and lugs on said catch-plate, said lugs extending rearwardly from one of the longitudinal edges of the said catch-plate and projecting into and being adapted to oscillate in the open portions 13, a finger-piece extending into and through the opening in the front of the casing and in an upward direction in front of the casing to provide a closure to the said opening, a spring, and a holding means connected with the other frame-section for engagement with said catch-plate, substantially as and for the purposes set forth.

2. In a bag-fastener for a frame having hinged frame-sections, said fastener comprising a chambered casing adapted to be secured to one of said frame-sections, and said casing having an opening in its front side and said casing being also provided with openings 13 in its opposite side, a catch-plate and lugs on said catch-plate, said lugs extending rearwardly from one of the longitudinal edges of the said catch-plate and projecting into and being adapted to oscillate in the open portions 13, a finger-piece extending into and through the opening in the front of the casing and in an upward direction in front of the casing to provide a closure to the said opening, a spring arranged upon the face of said catch-plate, said spring being provided with right-angled members, one of which lies upon said catch-plate and the other member resting against the inner surface of said casing, substantially as and for the purposes set forth.

3. In a bag-fastener for a frame having hinged frame-sections, said fastener comprising a chambered casing adapted to be secured to one of said frame-sections, and said casing having an opening in its front side and said casing being also provided with openings 13 in its opposite side, a catch-plate and lugs on said catch-plate, said lugs extending rearwardly from one of the longitudinal edges of the said catch-plate and projecting into and being adapted to oscillate in the open portions 13, a finger-piece extending into and through the opening in the front of the casing and in an upward direction in front of the casing to

provide a closure to the said opening, a spring
arranged upon the face of said catch - plate,
said spring being provided with right-angled
members, one of which lies upon said catch-
plate and the other member resting against
5 the inner surface of said casing, and means
for securing said spring to said catch-plate,
consisting of clamping-lugs integral with the
said catch - plate and clamped around said

spring, substantially as and for the purposes 10
set forth.

In testimony that I claim the invention set
forth above I have hereunto set my hand this
25th day of March, 1904.

ERNST E. WITTE.

Witnesses:

FREDK. C. FRAENTZEL,
GEO. D. RICHARDS.