

J. D. SEIPEL & C. B. ALSOVER.
CASE FOR ODOMETERS.

No. 111,008.

Fig. 1. Patented Jan. 17, 1871.

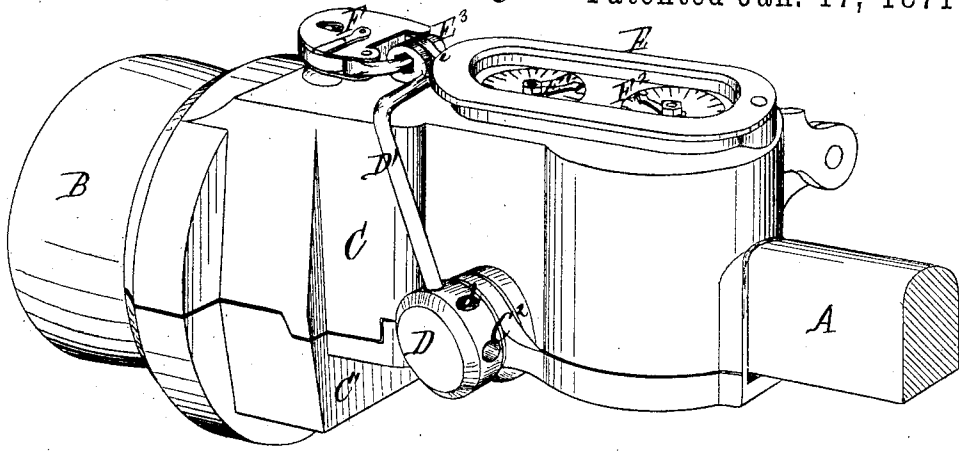
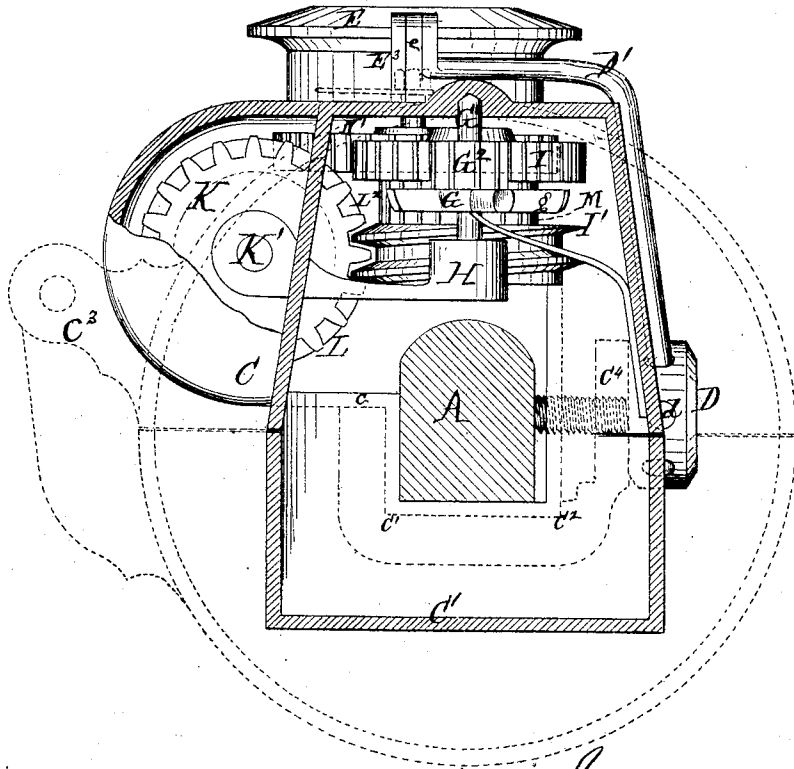

Fig. 2.



Witnesses
 Albert Mahon
 H. H. Doubleday

Jacob D. Seipel
 Cyrus B. Alsover
 by their Attorney
 A. M. Smith

J. D. SEIPEL & C. B. ALSOVER.
CASE FOR ODOMETERS.

No. 111,008.

Patented Jan. 17, 1871.

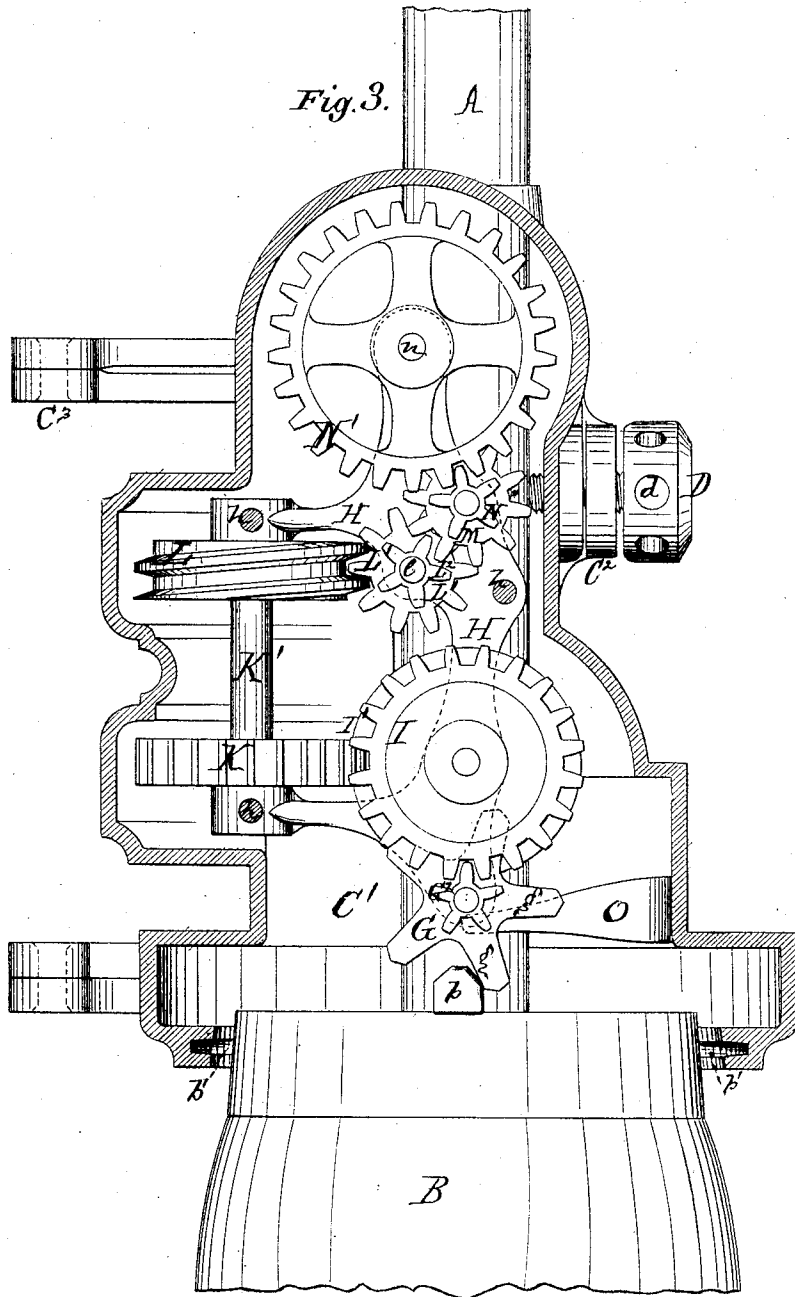

United States Patent Office.

JACOB D. SEIPEL AND CYRUS B. ALSOVER, OF EASTON, PENNSYLVANIA.

Letters Patent No. 111,008, dated January 17, 1871.

IMPROVEMENT IN CASES FOR ODOMETERS.

The Schedule referred to in these Letters Patent and making part of the same.

To all whom it may concern:

Be it known that we, JACOB D. SEIPEL and CYRUS B. ALSOVER, both of Easton, county of Northampton, State of Pennsylvania, have invented certain new and useful Improvements in Odometers, of which the following is a full, clear, and exact description, reference being had to the accompanying drawing making part of this specification, in which—

Figure 1 is a perspective view of our improved odometer, showing it as being applied to a wagon-axle;

Figure 2 is an end view with a portion of the shell broken away; and

Figure 3 is a plan or top view with the upper half of the shell removed to show the gearing.

Similar letters of reference denote corresponding parts in all the figures.

In the drawing—

A represents an axle of a wagon;

B, the inner end of the hub of the wheel; and

b, a spur or stud projecting from the vertical face of the hub.

b' is a groove in the rim of the shell or case, adapted to receive a suitable elastic packing to exclude dust.

C C' is the shell or case, of irregular form, substantially as shown in fig. 1. It is divided into two parts, the upper part C extending down to a line with the lower side of the axle on one side, as shown in fig. 1, while on the other side the bottom part C' extends up nearly or quite to the upper side of the axle. This construction has been adopted on account of convenience in closing the parts around the axle, the two parts being hinged together at C².

The upper part C is much the larger, and contains all of the working parts, the lower part C' serving to assist in securing it to the axle, to exclude dirt, and to prevent the machine from being disturbed either through accident or design.

The machine is secured to the axle as follows:

The lower part C' is constructed with a channel or recess, indicated by dotted lines *c c' c''* in fig. 2, into which the axle fits, and is expanded upon its outer edge, that is, the edge furthest from the hinges, forming an ear, C², which projects above and outside of the lower edge of the upper part C, as is plainly shown in fig. 1, and is perforated at *c'*, fig. 2, for the reception of a clamp-screw, D, said perforation being provided with a screw-thread into which the clamp-screw fits, and the upper part C is also perforated at a point which corresponds to that in the lower part when the shell is closed.

After the machine has been placed upon the axle, as in fig. 1, the clamp-screw D is inserted far enough to impinge upon said axle, as in fig. 2 by which means the two parts of the shell are secured to each other

and to the axle, as will be readily understood without further explanation.

Upon the upper face of the machine there is a dial-chamber formed by a raised rim or flange, and covered by a hinged or pivoted lid, E, which may, when preferred, be provided with a glass plate through which the position of the pointers E¹ E² may be seen.

The lid E is shown as being secured to a perforated lug or staple, E³, by means of a small-padlock, F, the hasp of which passes through staple E³, an ear *e* on the lid, and the socket of a wrench, D'.

The shank of this wrench fits into holes *d* in the head of the clamp-screw, and serves the double purpose of tightening the screw and of locking it in place to prevent accidental displacement. Thus it is apparent that, by this combination and arrangement of devices, the lock F is made to secure the lid E and the clamp-screw D from being moved, except by first removing the lock.

G is a star-wheel, having any suitable number of arms *g*. It is mounted upon a short vertical shaft, G¹, and is actuated by the spur *b* on hub B, being moved forward one arm at each revolution of the carriage-wheel.

The upper end of shaft G¹ is supported in upper shell C, while its lower end rests in a step or bearing in a bridge-plate, H, shown partly in full lines and partly in dotted lines in fig. 3.

Bridge-plate H is rigidly attached to upper shell C by any desired number of pins *h*, and forms, in connection with said shell, the sole support for the registering mechanism.

G² is a spur-pinion, attached to or cast with star-wheel G, and gears with a spur-wheel, I, which, together with a worm or screw, I', are mounted upon vertical shaft *i*, see fig. 3.

The worm I takes into and drives a worm-wheel, K, (see fig. 2,) which is rigidly secured to a horizontal shaft, K', (see fig. 3,) which carries on its opposite end a screw, L, which, in turn, drives a worm-wheel, L', mounted upon a vertical shaft, and carrying with it a spur-pinion, L².

Worm-wheel L' is shown in fig. 3, but cannot be shown in fig. 2 because it is in the same horizontal plane with worm I', and directly behind it when the parts are in the position represented in this figure.

Pinion L² gears with pinion M, mounted rigidly on the same shaft with pinion N, this latter gearing with and driving the spur-wheel N'. Pinion N cannot be shown in fig. 2 except in dotted lines, because it is in the same horizontal plane with the spur-wheel I, and right behind it; in fact wheel N' is shown partly in dotted lines in this figure.

The shafts *l* and *n* project through the top of the upper shell C into the dial-chamber above described,

and carry on their projecting ends pointers $E^1 E^2$, which sweep over circles of figures arranged in the manner customary in this class of measuring-instruments, and need not, therefore, be further described.

O is a tongue-spring, one end of which is attached to the shell, while the free end rests upon the face of the star-wheel G for the purpose of retaining said wheel in the position to which it has been moved, as will hereinafter be explained.

In applying our register to a wagon or carriage, care should be taken that one of the arms or fingers of the star-wheel point pretty nearly directly at a right angle to the vertical face of the wheel-hub, substantially as represented in fig. 2, in order that, whichever way the vehicle be moved, the star-wheel shall be in proper position to be actuated by the spur b , when the mechanism may be secured to the axle by means of clamp-screw D, as has already been explained.

At each forward revolution of the carriage-wheel, star-wheel G, pinion G¹, and spur-wheel I, will be moved forward one cog, and one complete revolution of wheel I and screw I¹ will move wheel K forward one cog, and so on through the entire train of gearing, the pointers $E^1 E^2$ indicating on the dials the distance traveled, the gears M and N acting as multiplying-gears, through which the pointer E^1 , carried by wheel M and shaft m , is made to revolve ten times while pointer E^2 revolves once. Thus pointer E^1 may be made to indicate single miles and pointer E^2 ten miles by moving from one figure to another on the dial.

It will be seen in fig. 1 that the eye at one end of the wrench D is adapted to fit the nuts which secure the pointers on the ends of their respective shafts.

By employing this peculiar form of shell, hinged together in this manner, we are enabled to attach our operating mechanism to the upper portion, thus protecting them entirely from the rain, and we can secure the two parts of the shell to each other and to the axle by a single clamp-screw.

We also, by our construction and arrangement of devices, provide against the register being removed from its proper place on the axle, and against the indicator being tampered with by the use of a single lock.

The dial-plate now attached to the machine is adapted to be used with a wheel of fifty-one inches diameter, but it is evident that provision may be made for applying the device to carriages having different-sized wheels by having a number of dials spaced corresponding to the wheels, and which can be readily applied by taking off the pointers. In case this is done, it would be well to indicate on the dial the sized wheel with which it is to be used.

When desired, pieces of rubber or leather may be interposed between the shell and the axle to prevent the latter from being bruised.

It will be readily seen that the pin b , which projects radially from the center of the hub, will, by engaging with the inner side of the rim of the shell C C', always be kept in proper working relation to the star-wheel, so that the wheel of the carriage cannot revolve without actuating the registering mechanism.

Having now described our invention.

What we claim as new, and desire to secure by Letters Patent, is—

1. In an odometer, the shell composed of two parts C C', hinged and secured to each other and to the axle by the clamp-screw D, substantially as set forth.

2. The combination of the hinged lid E, stationary lug E^2 , wrench D, nut D, and lock F, substantially as and for the purpose set forth.

JACOB D. SEIPEL.
CYRUS B. ALSOVER.

Witnesses:

I. R. INNIS,
THEODORE SCHUG.