

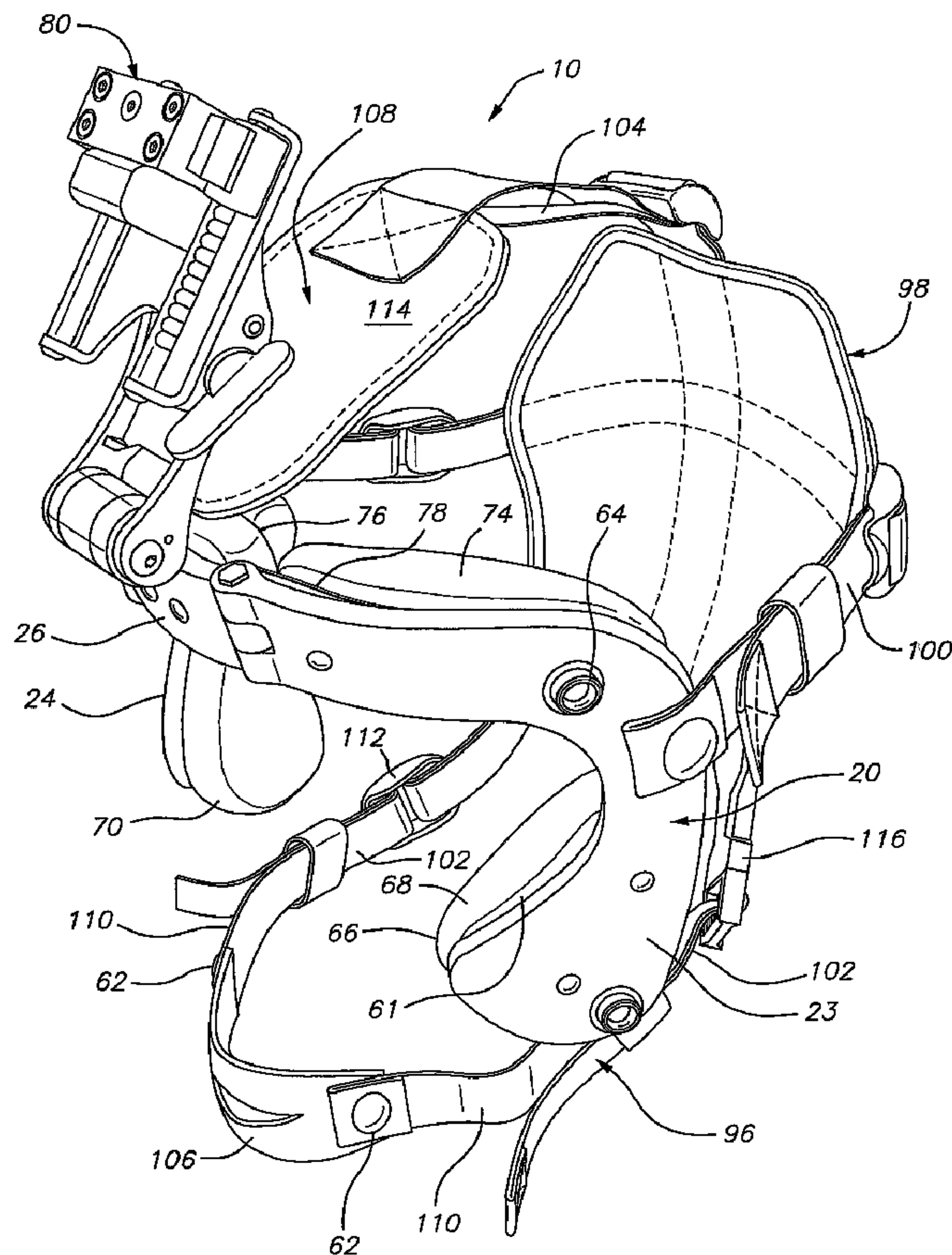

(86) Date de dépôt PCT/PCT Filing Date: 2004/01/05
 (87) Date publication PCT/PCT Publication Date: 2004/07/29
 (45) Date de délivrance/Issue Date: 2009/09/08
 (85) Entrée phase nationale/National Entry: 2005/06/30
 (86) N° demande PCT/PCT Application No.: US 2004/000157
 (87) N° publication PCT/PCT Publication No.: 2004/062400
 (30) Priorité/Priority: 2003/01/03 (US60/438,027)

(51) Cl.Int./Int.Cl. *G02B 7/00* (2006.01),
G02B 23/12 (2006.01), *G02B 27/01* (2006.01),
F41H 1/04 (2006.01)
 (72) Inventeurs/Inventors:
 SOTO, RONALD R., US;
 ROBINSON, DAVID A., US;
 PRENDERGAST, JONATHON R., US;
 SOTO, JOHN E., US;
 BARTH, PASCAL A., US
 (73) Propriétaire/Owner:
 NOROTOS, INC., US
 (74) Agent: FETHERSTONHAUGH & CO.

(54) Titre : ENSEMBLE MASQUE FACIAL POUR LUNETTES DE VISION NOCTURNE
 (54) Title: FACEMASK ASSEMBLY FOR NIGHT VISION GOGGLES



(57) Abrégé/Abstract:

A facemask assembly (10) for night vision goggles comprises a frame assembly (20), a mount assembly (80) for attachment of the night vision goggles, an adjustment strap assembly (96), and a neck pad assembly (98), wherein the frame assembly (20) is

(57) **Abrégé(suite)/Abstract(continued):**

generally C-shaped and contoured to extend across the upper forehead of a user, with each end of the generally C-shaped frame assembly extending down around the outside of the eyes and to the hollow of the cheeks of a user, below the cheek bones and above the jaw.

(12) INTERNATIONAL APPLICATION PUBLISHED UNDER THE PATENT COOPERATION TREATY (PCT)

(19) World Intellectual Property
Organization
International Bureau



(43) International Publication Date
29 July 2004 (29.07.2004)

PCT

(10) International Publication Number
WO 2004/062400 A3

- (51) International Patent Classification⁷: **F41H 1/04**
- (21) International Application Number: PCT/US2004/000157
- (22) International Filing Date: 5 January 2004 (05.01.2004)
- (25) Filing Language: English
- (26) Publication Language: English
- (30) Priority Data:
60/438,027 3 January 2003 (03.01.2003) US
- (71) Applicant (for all designated States except US): **NOROTOS, INC.** [US/US]; 201 E. Alton Avenue, Santa Ana, CA 92707-4416 (US).
- (72) Inventors; and
(75) Inventors/Applicants (for US only): **SOTO, Ronald, R.** [US/US]; 25435 Gallup Circle, Laguna Hills, CA 92653-6319 (US). **ROBINSON, David, A.** [US/US]; 8331 Hurstwell Drive, Huntington Beach, CA 92646 (US). **PRENDERGAST, Jonathon, R.** [US/US]; 280 Cagney Lane, Unit 315, Newport Beach, CA 92663 (US). **SOTO, John, E.** [US/US]; 25451 Gallup Circle, Laguna Hills, CA 92653 (US). **BARTH, Pascal, A.** [US/US]; 37 Via Gatillo, Rancho Margarita CA 92688 (US).
- (74) Agent: **DALY, Thomas, J.**; Christie, Parker & Hale, L.L.P., P.O. Box 7068, Pasadena, CA 91109-7068 (US).
- (81) Designated States (unless otherwise indicated, for every kind of national protection available): AE, AG, AL, AM, AT, AU, AZ, BA, BB, BG, BR, BW, BY, BZ, CA, CH, CN, CO, CR, CU, CZ, DE, DK, DM, DZ, EC, EE, EG, ES, FI, GB, GD, GE, GH, GM, HR, HU, ID, IL, IN, IS, JP, KE,

[Continued on next page]

(54) Title: FACEMASK ASSEMBLY FOR NIGHT VISION GOGGLES

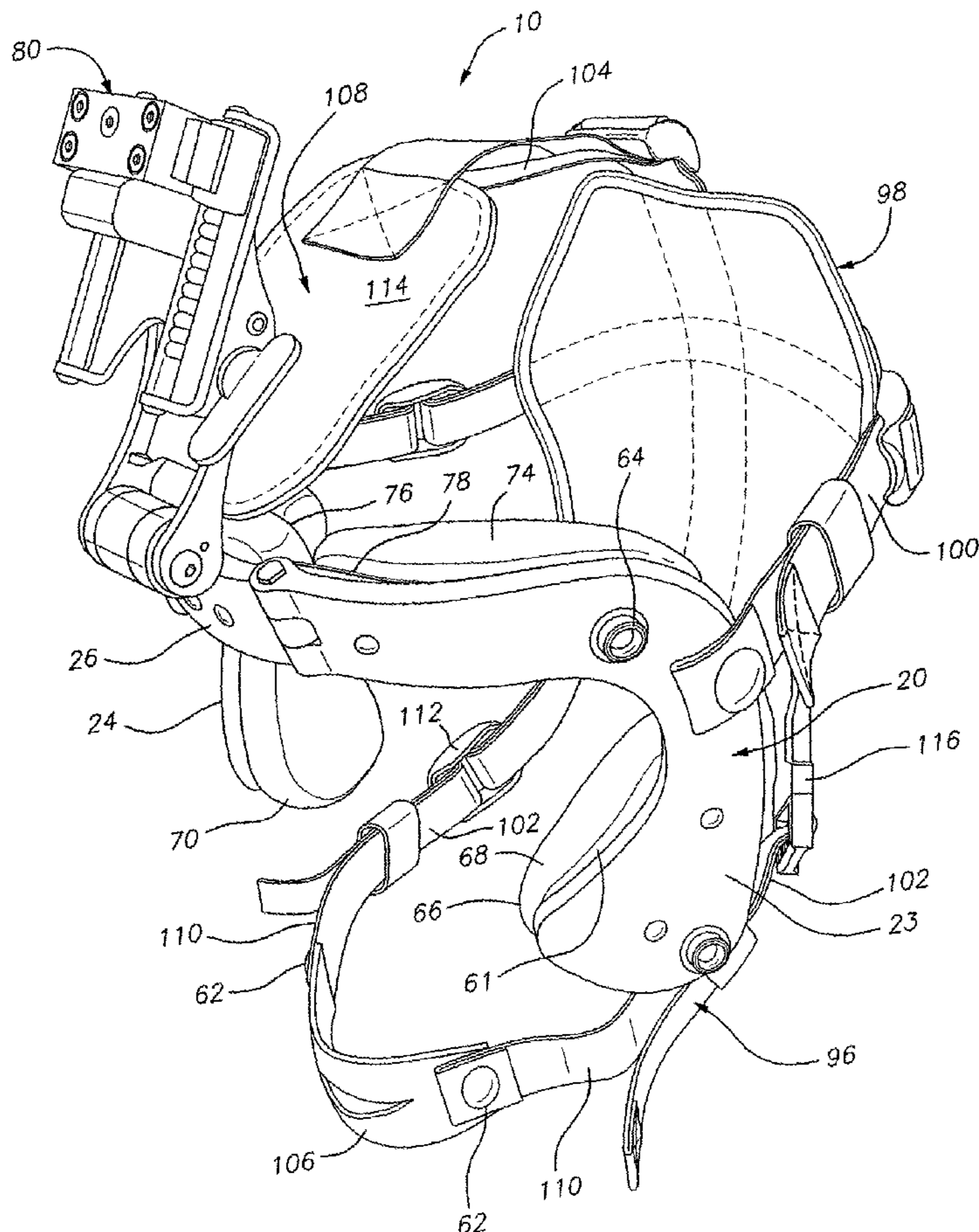

(57) Abstract: A facemask assembly (10) for night vision goggles comprises a frame assembly (20), a mount assembly (80) for attachment of the night vision goggles, an adjustment strap assembly (96), and a neck pad assembly (98), wherein the frame assembly (20) is generally C-shaped and contoured to extend across the upper forehead of a user, with each end of the generally C-shaped frame assembly extending down around the outside of the eyes and to the hollow of the cheeks of a user, below the cheek bones and above the jaw.

WO 2004/062400 A3

WO 2004/062400 A3

KG, KP, KR, KZ, LC, LK, LR, LS, LT, LU, LV, MA, MD, MG, MK, MN, MW, MX, MZ, NA, NI, NO, NZ, OM, PG, PH, PL, PT, RO, RU, SC, SD, SE, SG, SK, SL, SY, TJ, TM, TN, TR, TT, TZ, UA, UG, US, UZ, VC, VN, YU, ZA, ZM, ZW.

TR), OAPI (BF, BJ, CF, CG, CI, CM, GA, GN, GQ, GW, ML, MR, NE, SN, TD, TG).

Published:

— *with international search report*

(84) Designated States (*unless otherwise indicated, for every kind of regional protection available*): ARIPO (BW, GH, GM, KE, LS, MW, MZ, SD, SL, SZ, TZ, UG, ZM, ZW), Eurasian (AM, AZ, BY, KG, KZ, MD, RU, TJ, TM), European (AT, BE, BG, CH, CY, CZ, DE, DK, EE, ES, FI, FR, GB, GR, HU, IE, IT, LU, MC, NL, PT, RO, SE, SI, SK,

(88) Date of publication of the international search report:
24 February 2005

For two-letter codes and other abbreviations, refer to the "Guidance Notes on Codes and Abbreviations" appearing at the beginning of each regular issue of the PCT Gazette.

FACEMASK ASSEMBLY FOR NIGHT VISION GOGGLES

BACKGROUND

5 Facemask assemblies for night vision goggles generally consist of a headband
assembly, strap assembly, neck pad assembly, and mount assembly. The headband
assembly serves as the frame or foundation for the rest of the facemask assembly. The
strap assembly serves to fasten the headband assembly to varying users' head sizes and
shapes. The mount assembly serves to provide a means of mounting the night vision
10 goggles to the facemask assembly as well as providing the positioning adjustments for
aligning the night vision goggles to the user's line-of-sight.

Typical positioning adjustments provided by the mount assembly include fore/aft,
line-of-sight tilt, vertical, and interpupillary distance (IPD). Another function provided
by the mount assembly may be flip-up/flip-down or swing-away of the goggle mount.
15 These functions allow the night vision goggles to be removed from the user's line-of-
sight to a stowed position. This is necessary when the user needs to use his or her
unaided vision.

Previous facemask assemblies did not provide the comfort or stability necessary
for various night vision goggle operations as provided in embodiments of the present
20 invention. For example, when worn for extended periods of time, previous facemask
assemblies became very painful to various areas of users' heads due to, for instance, the
location and type of padding and the configuration of the frame. Likewise, these previous
facemask assemblies do not hold the night vision goggles in position for the user to use
them properly during physical operations such as running, jumping, crawling and rolling.

25 Also, previous facemask assemblies did not provide proper night vision goggle
positioning adjustments allowing the user to properly position the goggles in front of his
or her eyes to maximize the benefit of the night vision goggles' field-of-view and eye
relief. Previous facemask assemblies further did not provide a fold-away function
allowing the facemask assembly to be folded into a compact shape for storage.
30 Moreover, previous facemask assemblies did not provide a quick-release mechanism
allowing the user to quickly remove the facemask assembly from his or her head.
Finally, previous facemask assemblies mandated the use of a chin cup.

SUMMARY OF THE INVENTION

In one embodiment, the present invention provides a facemask assembly for night
5 vision goggles comprising, a frame assembly; a mount assembly for attachment of the
night vision goggles; an adjustment strap assembly; and a neck pad assembly, wherein
the frame assembly is generally C-shaped and contoured to extend across the upper
forehead of a user, with each end of the generally C-shaped frame assembly extending
down around the outside of the eyes and to the hollow of the cheeks of a user, below the
10 cheek bones and above the jaw.

In an alternative embodiment, the present invention provides a facemask
assembly for night vision goggles comprising, a frame assembly; a mount assembly for
attachment of the night vision goggles, an adjustment strap assembly and a neck pad
assembly, wherein the frame assembly is hinged to allow rotation of at least one portion
15 of the frame assembly with respect to the remainder of the frame assembly through a
limited range of motion between an open configuration for use and a folded
configuration for storage.

In yet another alternative embodiment, the present invention provides a facemask
assembly for night vision goggles comprising, a frame assembly; a mount assembly for
20 attachment of the night vision goggles; an adjustment strap assembly; a neck pad
assembly; and a protective pad positioned on top of a user's head when the facemask
assembly is being worn to protect the user's head from injury from the night vision
goggles when in a stowed position, wherein the frame assembly is generally C-shaped
and contoured to extend across the upper forehead of a user, with each end of the
25 generally C-shaped frame assembly extending down around the outside of the eyes and
to the hollow of the cheeks of a user, below the cheek bones and above the jaw, the
frame assembly resting only on a user's upper forehead and in the hollows of a user's
cheeks below the cheekbones and above the jaw bone; and wherein the frame assembly
is hinged to allow rotation of at least one portion of the frame assembly with respect to
30 the remainder of the frame assembly through a limited range of motion between an open
configuration for use and a folded configuration for storage.

BRIEF DESCRIPTION OF THE DRAWINGS

5 FIG. 1 is a perspective view of an embodiment of a facemask assembly of the present invention.

FIG. 2 is a perspective view of a frame assembly of the facemask assembly of FIG. 1.

FIG. 3 is a perspective view of a hinge end of a frame member of the present invention.

10 FIG. 4a is a side view of one surface of a frame member of the present invention.

FIG. 4b is a side view of the opposite surface of the frame member of FIG. 4a.

FIG. 5 is a top view of a bridge of the frame assembly of FIG. 2.

FIG. 6a is a front view of a hinge pin of the frame assembly of FIG. 2.

FIG. 6b is a side view of a hinge pin of the frame assembly of FIG. 2.

15 FIG. 7 is a perspective view of an interior of a pad of the present invention.

FIG. 8 is a perspective view of an alternate configuration of an adjustment strap assembly of the present invention.

DETAILED DESCRIPTION

20

The facemask assembly **10** of one embodiment of the present invention is designed

1

for maximum comfort and stability. This has been accomplished through the shape and padding of the facemask frame, as well as the neck pad and strap adjustments. The design also provides sufficient stability of night vision goggles during quick movement operations and allows the user to align the optical axis of the night vision goggles to his or her line-of-sight for optimal viewing.

5
10
15
In one embodiment as shown in FIG. 1, the facemask assembly **10** may comprise a frame assembly **20**, a mount assembly **80**, an adjustment strap assembly **96** and a neck pad assembly **98**. The frame assembly **20** serves as the foundation for the other remaining components of the facemask assembly **10**. The frame assembly **20** is designed to properly fit the differing anthropometric shapes of the 5th to 95th percentile human head. Further, the curvatures of the frame assembly **20** fit the human face in a manner which minimizes discomfort by avoiding sensitive areas of the face and by spreading the load area over sufficient surface area.

20
In one embodiment, the facemask assembly **10** includes a frame assembly **20** as shown in FIG. 2. The frame assembly **20** may comprise a first frame member **23**, a second frame member **24** and a bridge **26** between the first and second frame members. The second frame member **24** is a mirror image of the first frame member **23**. Therefore, for clarity, only the first frame member **23** will be discussed in detail.

25
30
The first frame member **23** may comprise a body **40**, a hinge end **27**, and a cheek end **44**. As shown in FIG. 3, the hinge end **27** on the first frame member **23** includes an upper cylinder **28** and a lower cylinder **30** separated by a recess **32** adapted to receive an arm **82** from the bridge **26** (discussed in more detail below). The upper cylinder **28** may have an opening **34** running through the length of the cylinder adapted to allow a hinge pin **36** to be passed therethrough. For instance, the opening **34** may be hexagonal in cross section at an upper end and circular in cross section at a lower end in order to receive and be consistent with the shape of a head and upper shaft of the hinge pin **36**. The hexagonal cross section upper end and hexagonal head act to hold the hinge pin in place and to prevent rotation of the hinge pin relative to the frame member. Similarly, the lower cylinder **30** may also have an opening **38** adapted to allow a lower shaft of the hinge pin to be passed therethrough. The opening **38** may have a flat or a non-circular cross section however, to provide a stop on which the inserted hinge pin **36** may rest to assist in preventing it from rotating relative to the frame member.

35
Extending from the hinge end **27** of the first frame member **23** is the body **40**. The body **40** of the first frame member **23** is designed to generally follow the contour of a human face from the upper forehead above the eyebrows, around the eyes and to the hollow of the cheek below the cheek bones and above the jaw. One example of a shape of the body **40** is shown in two dimensions in FIG. 4a and in three dimensions is described by data provided in

Table A corresponding to the points shown in FIG. 4b. The data are points in a Cartesian coordinate system and, when entered into an appropriate software application, such as **ProE, or CAD**, the resulting points cloud will provide an exemplary three-dimensional shape of the body **40** of the first frame member **23**.

5

TABLE A

Refer to Figure 4B of the Drawings for Coordinates of Points 1-22 DATUM ESTABLISHED PER .40 DIA. AS PRIMARY AND .39 WIDTH AS SECONDARY DATUM. POINT CHECKED (-Z- AXIS) NEEDS TO ADD .01917 PROBE RADIUS			
	No. 1		
21	MEASURE X-Coordinate Y-Coordinate Z-Coordinate	0.23232 0.28089 0.30554	----> Point
	No. 2		
22	MEASURE X-Coordinate Y-Coordinate Z-Coordinate	0.25577 -0.40801 0.32367	----> Point
	No. 3		
23	MEASURE X-Coordinate Y-Coordinate Z-Coordinate	0.31682 -0.04971 0.35488	----> Point
	No. 4		
24	MEASURE X-Coordinate Y-Coordinate Z-Coordinate	1.42660 0.19321 0.64826	----> Point
	No. 5		
25	MEASURE X-Coordinate Y-Coordinate Z-Coordinate	1.42643 -0.24002 0.64488	----> Point
	No. 6		
26	MEASURE X-Coordinate Y-Coordinate Z-Coordinate	1.42585 -0.60846 0.63836	----> Point
	No. 7		
27	MEASURE X-Coordinate Y-Coordinate Z-Coordinate	2.51786 -0.13600 0.51032	----> Point
	No. 8		
28	MEASURE X-Coordinate Y-Coordinate Z-Coordinate	2.45738 -0.50791 0.51987	----> Point
	No. 9		
29	MEASURE X-Coordinate Y-Coordinate Z-Coordinate	2.45138 -0.90479 0.51366	----> Point
	No. 10		
30	MEASURE X-Coordinate Y-Coordinate Z-Coordinate	3.30732 -0.79157 0.12274	----> Point
	No. 11		
31	MEASURE X-Coordinate Y-Coordinate Z-Coordinate	3.06898 -1.35673 0.25111	----> Point
	No. 12		
32	MEASURE X-Coordinate Y-Coordinate Z-Coordinate	2.88721 -1.82804 0.32459	----> Point
	No. 13		
33	MEASURE X-Coordinate Y-Coordinate Z-Coordinate	3.55407 -1.87876 -0.09626	----> Point

	No. 14		
34	MEASURE X-Coordinate Y-Coordinate Z-Coordinate	3.04127 -2.54722 0.21705	----> Point
	No. 15		
35	MEASURE X-Coordinate Y-Coordinate Z-Coordinate	3.28070 -3.28184 0.03313	----> Point
	No. 16		
36	MEASURE X-Coordinate Y-Coordinate Z-Coordinate	2.64113 -3.34156 0.35334	----> Point
	No. 17		
37	MEASURE X-Coordinate Y-Coordinate Z-Coordinate	2.35835 -2.73214 0.46852	----> Point
	No. 18		
38	MEASURE X-Coordinate Y-Coordinate Z-Coordinate	1.65221 -3.18597 0.55964	----> Point
	No. 19		
39	MEASURE X-Coordinate Y-Coordinate Z-Coordinate	2.22486 -3.73500 0.44891	----> Point
	No. 20		
40	MEASURE X-Coordinate Y-Coordinate Z-Coordinate	3.29366 -3.31832 0.02149	----> Point
	No. 21		
41	MEASURE X-Coordinate Y-Coordinate Z-Coordinate	2.87489 -4.12237 0.20290	----> Point
	No. 22		
42	MEASURE X-Coordinate Y-Coordinate Z-Coordinate	1.50494 -4.30583 0.53379	----> Point

In one embodiment, the body **40** is substantially C-shaped and tapers outward to form the cheek end **44**. Although the exact width of the body **40** is not critical, the body should be wide enough to provide enough surface area so that correspondingly-sized padding (to be discussed in more detail below) attached to the body provides comfort to a user wearing the facemask assembly **10** for long periods of time. However, the body **40** should not be so wide as to make the facemask assembly **10** unduly heavy, bulky and difficult to store. In one particular embodiment, the body **40** has a minimum width of about **1** inch near the hinge end and a maximum width of about **2** inches near the cheek end.

The first frame member **23** may be manufactured from a durable, yet lightweight and flexible material. Durability is desired for stability in operation of the mount assembly and to withstand wear and tear during long term use. Light weight and flexibility are desired for comfort to the wearer during long term use. More specifically, the first frame member **23** may be manufactured from a plastic or polymer material, such

as a polyamide resin system, and even more specifically, the first frame member may be manufactured from nylon 6/6.

The first frame member **23** has an exterior surface **46** (see FIG. 4b) and an interior surface **48** (see FIG. 4a). In one embodiment, the exterior surface **46** may be smooth and streamlined in order to enable it to avoid snag hazards. The interior surface **48** may include ribs **50**. The ribs **50** serve to add rigidity to the frame member **23**. A greater number and denser concentration of ribs **50**, as well as thicker ribs, may be used to provide the frame member **23** with greater rigidity. Greater rigidity is desirable at the hinge end of the frame members to provide stability for operation of the mount assembly. Whereas, greater flexibility is desirable at the cheek end of the frame members to allow for adjustment to conform comfortably to a wearer's face. The interior surface **48** may also include circular protrusions **52** which serve as a base for snap attachment members **54**. Snap attachment members **54** are adapted to receive snaps **64** (discussed in more detail later) and may be attached to either or both the exterior and interior surfaces **46**, **48** of the frame members **23**, **24**.

The bridge **26** serves to connect the first frame member **23** to the second frame member **24** and also serves as a base for the mount assembly **80**. The bridge may be substantially rectangular and has two arms **82** extending laterally from each side. The arms **82** are adapted to fit into the recess **32** of the first and second frame members **23**, **24**. A circular cross section opening **84** runs through the center of each arm **82**. When the arms **82** are inserted into the recess **32** of the frame members **23**, **24**, the opening **84** in the arm may be

1

aligned with the openings **34** and **38** in the upper and lower cylinders **28**, **30** of the frame members **23**, **24** to allow the hinge pin **36** to be inserted therethrough. Additionally, the opening **84** in the arm **82** may include a stop pin **88** or other stop feature (see FIG. 5). In one embodiment, the stop pin **88** comprises a cylindrical dowel, preferably made of metal, coaxial to the opening **84**, wherein the stop pin **88** partially protrudes into the otherwise circular cross section opening.

The frame assembly could be formed in a single piece in an open configuration adapted to fit on a wearer's face. However, to allow the frame assembly to be folded into a more compact configuration for storage, the frame assembly may be comprised, as shown in the drawings, of multiple pieces that are hinged for rotation relative to one another.

A foldable frame assembly may further comprise two hinge pins **36**. The hinge pins **36**, in a particular embodiment, may include a hexagonal head **92** and a generally cylindrical shaft or body **94**. The body **94** may further include a flat **90**. The exact shape of the hinge pin **36** in this particular foldable embodiment is not critical, but rather the pin should be shaped such that it corresponds to the shape of the openings **34**, **38**, **84** and also so that it does not rotate relative to the frame members but does allow the frame member to rotate through at least some range of motion relative to the bridge.

In a foldable embodiment of the present invention, the frame members **23**, **24** are rotatable. When the hinge pin **36** is inserted through the openings **34**, **38**, **84**, the stop pin **88** in the bridge opening **84** acts to restrict the rotatability of the hinge pin **36** to a particular range of motion. More specifically, when the frame members **23**, **24** are rotated, the flat **90** of the hinge pin **36** pivots relative to the stop pin **88** in a limited range of motion rather than being able to rotate freely for 360 degrees. At one end of that range of motion, the frame members are positioned relative to the bridge to be at the optimal open configuration for use by a wearer. At the other end of that range of motion, the frame members are positioned relative to the bridge to be at the optimal closed configuration for storage.

Additionally, the bridge **26** may include two snap attachment members **54** which allow the attachment of a brow pad (discussed in more detail below). In one embodiment, the bridge **26** is made from aluminum. However, the bridge **26** may be made from any lightweight, durable and rigid material.

The bridge **26** may also be adapted to serve as the base for a mount assembly **80**. In one embodiment, the mount assembly **80**, to which night vision goggles (not shown) are attached, may have three positions. A first, or use, position allows a user to see out of night vision goggles attached to the mount assembly **80**. A second, stowed or flipped-up, position allows the user to move the mount assembly **80** above their head so that the goggles do not interfere with the user when they are not needed. A third, or storage, position allows a user to fold the mount assembly **80** back over the first and second frame members **23**, **24** to form the

1

most compact orientation of the facemask assembly **10** for storage.

5

10

Padding may be attached to the interior surface of the frame members **23, 24** to provide comfort for the facemask assembly user. In one embodiment, a pad **62** may include an outer protective sheath and two layers of foam to provide for maximum comfort. A first layer **56** of foam, away from the user's face, may be a polyurethane foam and may have a thickness of about 0.25 inch, a density of about 15 lbs/cu. ft and a compression of about 1 to 5 psi. Specifically, the first layer **56** of foam may be Poron. A second layer **58** of foam, closest to the user's face, may also be a polyurethane foam and may have a thickness of about 0.5 inch, a density of about 2 lbs/cu. ft and a compression of about 0.7 psi. Specifically, the second layer **58** of foam may be Unifoam. The first and second layers of foam **56, 58** may be attached together by an adhesive or by any other appropriate means of securing them together. The second layer of foam is designed to form itself around the facial features with minimal pressure applied. The first layer of foam allows for additional cushioning as needed where increased pressure is created by tightening the facemask to the face in order to hold it securely during operation.

15

20

In an alternate embodiment, the second foam layer **58** is replaced by an air bladder (not shown). The air bladder may have similar thickness, density and compression qualities as the second layer of foam **58**.

25

Adjacent to the first layer **56** of foam may be a first molded backplate **60** which serves as a base for the foam layers **56, 58** and as a means to which the outer protective sheath or a covering **66** may be attached. The first molded backplate **60** may be molded to follow the contour of the part of the frame member **23, 24** to which it will be attached. The first molded backplate **60** may be manufactured from nylon 6/6 or any other appropriate lightweight and durable material.

30

The covering **66** may surround the two layers of foam **56, 58** and the first molded backplate **60**. Preferably, the covering **66** is durable yet comfortable when it is in contact with human skin for extended periods of time. In one embodiment, the covering **66** is sheepskin leather and may be attached to the first molded backplate **60** by an adhesive or any other appropriate means of attachment.

35

A second molded backplate **61** serves to hold means to attach the pad **62** to the facemask assembly **10** and to shape the surface of the pad **62** adjacent to the facemask assembly. The second backplate **61** may be attached to the covering **66** and/or the first molded backplate by an adhesive or any other appropriate means of attachment. Further, the second molded backplate **61** may be manufactured from the same material as the first molded backplate **60**.

The pads may be fixedly attached to the facemask. In one alternative embodiment, the pads **62** may removably attached to the facemask assembly **10** by snaps **54/64**. The snap

1
system provides a robust means of retaining the pads **62** to the frame assembly **20** as well as
an easy method for removing the pads to allow for easier cleaning of dirty pads or replacing
5 worn pads. At least one snap **54/64** is attached to a pad **62**, and in one embodiment, two snaps
54/64 are attached to each pad. Having two snaps **54/64** provides added security against a
pad **62** inadvertently detaching from the facemask assembly **10**. Alternately, the pads **62** may
attach to the facemask by VELCRO® or by any other attachment means that securely attach
the pads to the facemask assembly, yet allow the pads to be easily and quickly removed and
10 reattached.

The number of pads **62** on the facemask assembly **10** is not critical. However, there
should be enough pad surface area to make the facemask assembly **10** comfortable to wear
for extended periods of time by distributing pressure over a wider surface, but not so much
pad surface area so as to make the facemask assembly **10** too bulky for compact storage.

15 One embodiment of the present invention includes five pads: first and second cheek
pads **68, 70** and first, second and third brow pads **72, 74, 76**. The first and second cheek pads
68, 70 attach to the cheek end **44** of the first and second frame members **23, 24** respectively
and are positioned to rest in the hollow of the user's cheek below the cheek bone and above
the jaw bone when the facemask assembly **10** is worn. The first and second brow pads **72, 74**
20 attach to the body of the first and second frame members **23, 24** respectively, adjacent the
hinge end **27**. The third brow pad **76** attaches to the bridge **26**. The brow pads are positioned
to rest on a user's forehead above the sinus cavities, eyebrows and other sensitive areas near a
user's eyes. In a particular embodiment, the first, second and third brow pads **72, 74, 76** may
be connected together by a ribbon **78** which is placed between the first and second molded
25 backplates **60, 61** and may be secured there by an adhesive. The ribbon **78** serves to keep the
brow pads **72, 74, 76** together as one unit, making them more difficult to misplace.

In one embodiment of the present invention, the frame assembly **20** is transformable
between a storage position and a use position. In the storage position, the frame assembly **20**
may be folded down to a compact shape for storage in a carrying case (not shown). If the
30 frame assembly **20** could not be formed into a compact storage position, the facemask
assembly **20** would be difficult to store in a small compartment and would be more
susceptible to damage during storage. The ability to fold the facemask assembly **20** into a
compact shape helps to minimize the bulk of equipment the user must carry as well as to
protect it while it is in storage.

35 In the storage position, the frame members **23, 24** are positioned such that the first
cheek and brow pads **68, 72** are adjacent the second cheek and brow pads **70, 74**, i.e., the
angle formed by the bridge **26** and each frame member **23, 24** is about 90 degrees or less. In
a particular embodiment, pads **68** and **72** will touch pads **70** and **74**, respectively, in the
storage position. The stop pin may restrict further motion so that the pads will not be

1

damaged during storage by being crushed into one another or other parts of the facemask. On the other hand, in the use position, the frame members 23, 24 are rotated such that when worn by a user, the brow pads 72, 74, 76 will line the user's upper forehead and the cheek pads 68, 70 will rest in the hollows of the user's cheeks. In the use position, the angle between the bridge 26 and each frame member 23, 24 is about 145 degrees or more. In one particular embodiment, the angle between the bridge 26 and each frame member 23, 24 is about 180 degrees.

10 The shape of the frame assembly 20 is designed to accommodate most eyewear, including protective eyewear. The frame assembly 20 does not incorporate padding between the browpads and cheek pads, allowing the arms or straps of eyewear to pass between the frame members 23, 24 and the user's face. Since many users of night vision equipment use protective or corrective eyewear during operations, this enables most users to wear their
15 eyewear in conjunction with the facemask assembly 10 .

The mount assembly 80 provides the functions of night vision goggles mounting, fore/aft adjustment, line-of-sight tilt adjustment, and flip-up/flip-down. It also incorporates a magnet module participating in the function which turns the night vision goggles off if the night vision goggles is removed from the mount assembly or flipped-up to the stowed
20 position. These mechanisms are described in greater detail in U.S. Patent No. 5,914,816 to Soto, et al.

The neck pad assembly 98 is also designed for comfort and stability. The neck pad assembly 98 serves as an anchor point for the facemask assembly 10 once the assembly is put on. Specifically, in one embodiment, all of the straps of the adjustment strap assembly 96 (described in more detail below) may connect into the neckpad assembly 98. The neck pad assembly 98 grips the lower rear portion of the user's head providing stability to the frame assembly 10 and night vision goggles (not shown) during operations such as running, jumping and crawling. The particular shape of the neckpad assembly 98 is not critical. However, the neckpad assembly 98 should be of such a shape as to provide a stable anchor
25 for the facemask assembly 10 as well as a comfortable support for the user. The materials used in the neck pad assembly 98 should provide strength and breathability to maximize ruggedness and comfort to the user during periods of extended operation. The neckpad assembly 98 may be manufactured from any flexible, yet durable material, for instance, nylon.

30 The adjustment strap assembly 96 as shown in FIG. 1 may comprise two upper side straps 100, two lower side straps 102, an upper center strap 104, a chin cup 106, and a protective pad 108. All adjustment straps may be tightened by pulling the end of the adjusting strap towards the front of the head. At least one of the lower side straps 102 incorporates a quick-release buckle 116 enabling the user to quickly remove the facemask
35

1

assembly **10** if necessary. This also enables the user to quickly don the facemask assembly **10** if the adjustment straps have been previously fit to his or her head.

5 The chin cup **106** is an open design adapted to generally conform to the shape of a human chin. The chin cup **106** may further include straps **110** extending from either side. The straps **110** may be removably attached to the chin cup **106** by snaps **62** or by any other appropriate attachment means. This design positions the user's chin in the chin cup **106** between the two straps and securely holds the chin cup **106** in position during operation. The
10 chin cup **106** is designed so that it cannot be assembled backwards or upside-down. Further, the shape of the chin cup **106** is symmetric both vertically and horizontally. The chin cup **106** may be manufactured from any durable but flexible material. For instance, the chin cup **106** may be made from nylon and may also incorporate sheepskin leather next to the user's skin for additional comfort.

15 Each adjustment strap may further incorporate a plastic self-locking buckle or ladder lock **112**, as commonly found on, for instance, straps on a backpack. The buckles **112** may preferably be easy to use and have a low profile shape. Each buckle **112** allows the adjustment strap to easily be pulled for tightening and then holds the strap in position until the user pulls out on the buckle. The low profile shape of the buckles **112** helps prevent the
20 inadvertent release of the straps by external items such as underbrush and cables.

The protective pad **108** serves to protect the user's head from injury if the mount assembly **80** rotates past the stowed position and comes in contact with the top of the user's head while the user is wearing the facemask assembly **10**. The mount assembly **80** is designed to rotate past the stowed position to a storage position which configures the
25 facemask assembly **10** for compact storage. However, the user may suffer an injury if the mount assembly **80** was able to strike the top of the head during maneuvers. The protective pad **108** incorporates a hard plastic shield **114** which distributes any force over a broad area and drastically reduces the possibility of a point impact to the user's head. The protective pad **108** may be made from a flexible durable exterior surface for ruggedness, a soft interior layer
30 and a comfortable covering next to the user's head. For instance, the exterior may be nylon 6/6, the interior may be foam and the covering may be sheepskin leather.

The adjustable strap assembly **96** can be configured into at least two different configurations according to the user's preference. A first configuration, as shown in FIG. 1, includes the chin cup **106** and a second configuration, as shown in FIG. 8, does not include
35 the chin cup. These alternate configurations give the user the opportunity to choose his or her preferred configuration. Typical users' preferences vary depending on the user's facial profile, their personal history with night vision goggles equipment, and their operational missions' requirements.

1

In the first configuration, the upper side straps **100** are attached to middle snap locations on the frame assembly **20** and the lower side straps **102** are attached to the chin cup **106**. This leaves the upper snap locations and the lower snap locations on the frame assembly **20** unused.

5

In the second configuration, the upper side straps **100** are attached to the upper or middle snap locations on the frame assembly **20** and the lower side straps **102** are attached to the lower snap locations on the frame assembly **20**. This leaves potentially the middle snap locations on the frame assembly **20** and the chin cup **106** unused.

10

The straps may be made of any strong, durable and flexible material. By way of example, the straps may be made of a woven nylon mesh material.

The adjustment straps are easy to use and incorporate a quick-release buckle for rapid removal. The strap assembly also offers the user multiple mounting configurations making the use of a chin cup optional. The night vision goggles positioning provided by the mount assembly allows the user to properly position the night vision goggles in front of their eyes. The flip-up/flip-down mechanism provides the ability of moving the night vision goggles into a stowed position when the night vision goggles needs to be removed from the user's line-of-sight.

15

20

While the foregoing describes the preferred embodiments of the invention, various alternatives, modifications and equivalents may be used. For instance, the number of pads used in the frame assembly **20** may be varied. Moreover, it will be obvious that certain other modifications may be practiced within the scope of the appended claims.

25

30

35

The embodiments of the invention in which an exclusive property or privilege is claimed are defined as follows:

1. A facemask assembly for night vision goggles comprising,
5 a frame assembly;
a mount assembly for attachment of the night vision goggles;
an adjustment strap assembly; and
a neck pad assembly,
wherein the frame assembly is generally C-shaped and contoured to
10 extend across the upper forehead of a user, with each end of the generally C-shaped
frame assembly extending down around the outside of the eyes and to the hollow of the
cheeks of a user, below the cheek bones and above the jaw.
2. A facemask assembly according to claim 1 also comprising at least one
15 forehead pad attached to the frame assembly and positioned to be between the frame
assembly and the upper forehead of a user when the facemask assembly is being worn by
the user.
3. A facemask assembly according to claim 1 or 2 also comprising a pair of
20 cheek pads, a first cheek pad attached to one end of the frame assembly and positioned to
be between the frame assembly and the hollow of the cheek of a user when the facemask
assembly is being worn by the user and a second cheek pad attached to the other end of
the frame assembly and positioned to be between the frame assembly and the hollow of
the other cheek of the user when the facemask assembly is being worn by the user.
25
4. A facemask assembly according to claim 2 or 3 wherein the pads are
removably attached to the frame assembly.
5. A facemask assembly according to claim 4 wherein the pads are
30 removably attached using at least one snap for each pad.

6. A facemask assembly according to claim 4 wherein the pads are removably attached using at least two snaps for each pad.

7. A facemask assembly according to claim 4 wherein the pads are
5 removably attached using loop and pile fasteners.

8. A facemask assembly according to any one of claims 2 to 6 wherein the pads are covered with a protective sheath.

10 9. A facemask assembly according to claim 8 wherein the protective sheath is made of sheepskin leather.

10. A facemask assembly according to any one of claims 2 to 6 wherein the pads are comprised of a foam material.

15

11. A facemask assembly according to claim 10 wherein a first portion of the foam material positioned closest to a user's face when the facemask is being worn is adapted to form itself around facial features while applying minimal pressure.

20 12. A facemask assembly according to claim 11 wherein the first portion is a polyurethane foam with a thickness of about 0.5 inch, having a density of about 2 lbs./cu. ft. and a compression of about 0.7 psi.

25 13. A facemask according to claim 11 wherein a second portion of the foam material positioned outside the first portion is adapted to allow for additional cushioning.

14. A facemask according to claim 13 wherein the second portion is a polyurethane foam with a thickness of about 0.25 inch, having a density of about 15 lbs/cu.ft. and a compression of about 1 to 5 psi.

30

15. A facemask assembly according to any one of claims 1 to 14 wherein the frame assembly is made from a durable, lightweight and flexible material.

5 16. A facemask assembly according to any one of claims 1 to 15 wherein the frame assembly is made from nylon 6/6.

17. A facemask assembly according to any one of claims 1 to 16 wherein the frame assembly is hinged so that the facemask assembly can be folded into a more compact configuration when not in use.

10

18. A facemask assembly according to any one of claims 1 to 17 wherein the frame assembly has an exterior surface that is smooth and streamlined.

15 19. A facemask assembly according to claim 3 wherein there is a gap between the at least one forehead pad and each of the cheek pads.

20. A facemask assembly for night vision goggles comprising,
a frame assembly;
a mount assembly for attachment of the night vision goggles;
20 an adjustment strap assembly; and
a neck pad assembly,
wherein the frame assembly is hinged to allow rotation of at least one portion of the frame assembly with respect to the remainder of the frame assembly through a limited range of motion between an open configuration for use and a folded
25 configuration for storage.

21. A facemask assembly for night vision goggles comprising,
a frame assembly;
a mount assembly for attachment of the night vision goggles;
30 an adjustment strap assembly;
a neck pad assembly; and

a protective pad positioned on top of a user's head when the facemask assembly is being worn to protect the user's head from injury from the night vision goggles when in a stowed position, wherein the frame assembly is generally C-shaped and contoured to extend across the upper forehead of a user, with each end of the
5 generally C-shaped frame assembly extending down around the outside of the eyes and to the hollow of the cheeks of a user, below the cheek bones and above the jaw, the frame assembly resting only on a user's upper forehead and in the hollows of a user's cheeks below the cheekbones and above the jaw bone; and

wherein the frame assembly is hinged to allow rotation of at least one
10 portion of the frame assembly with respect to the remainder of the frame assembly through a limited range of motion between an open configuration for use and a folded configuration for storage.

15

FIG. 1

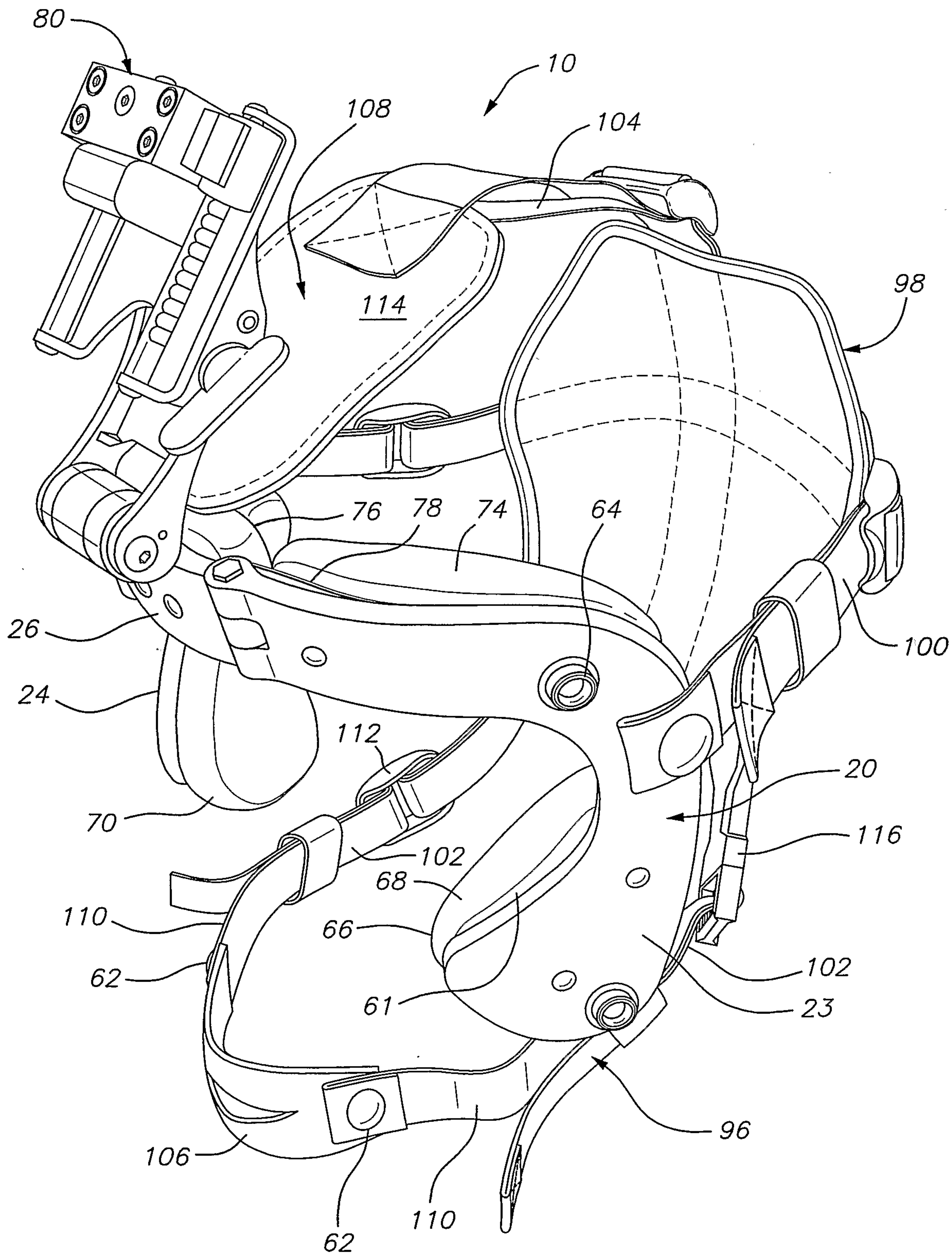

FIG. 2

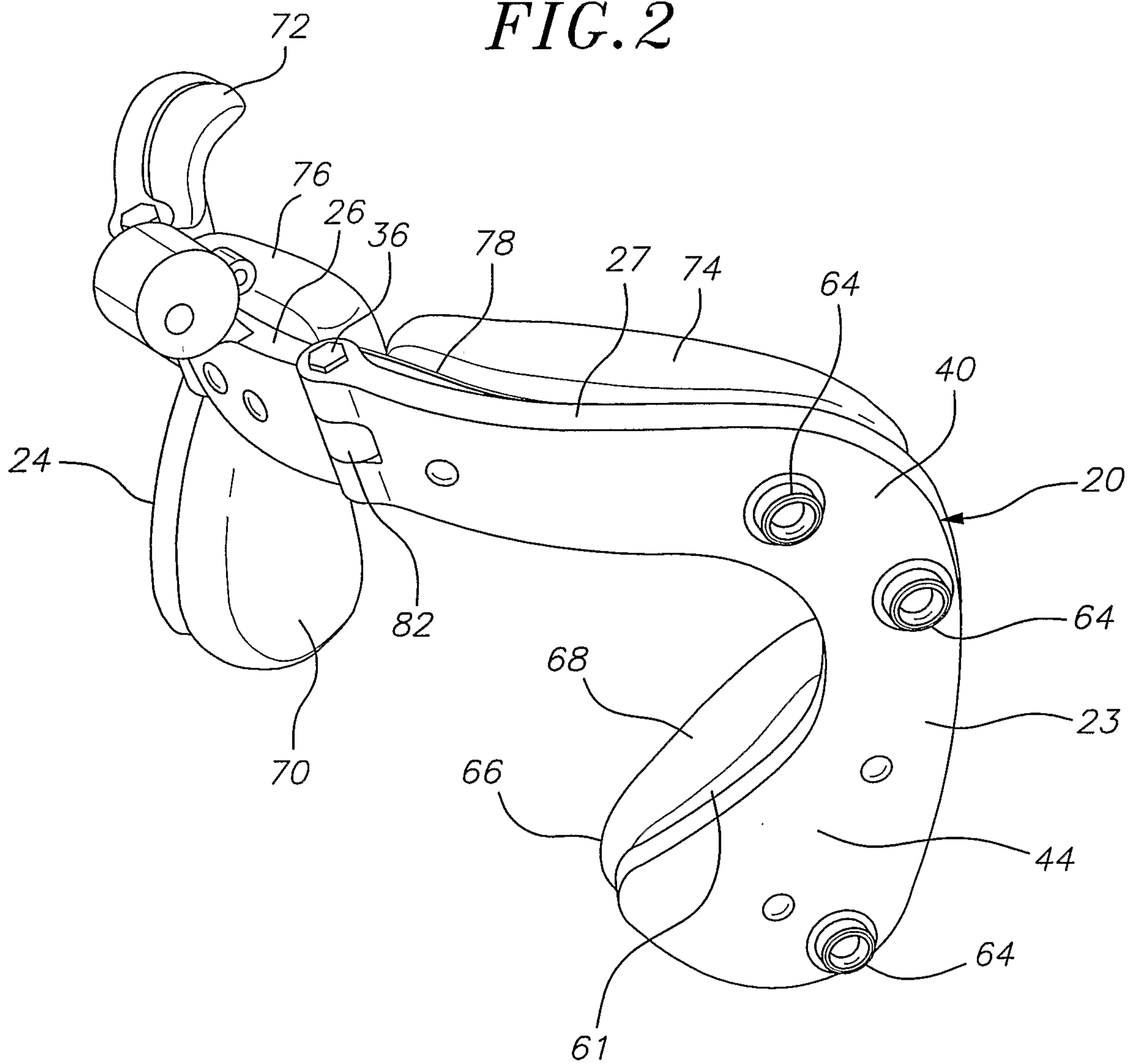

FIG. 3

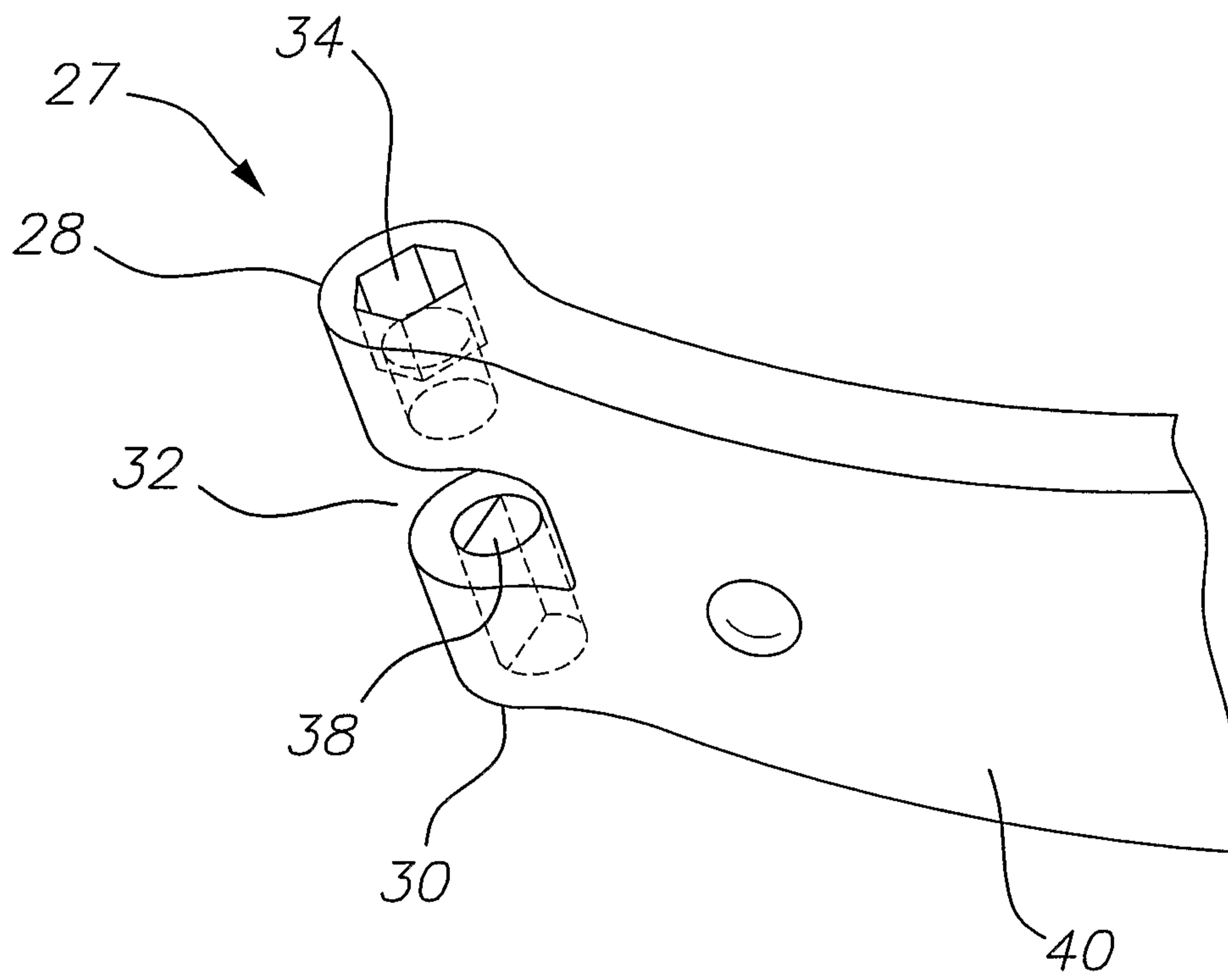

FIG. 4A

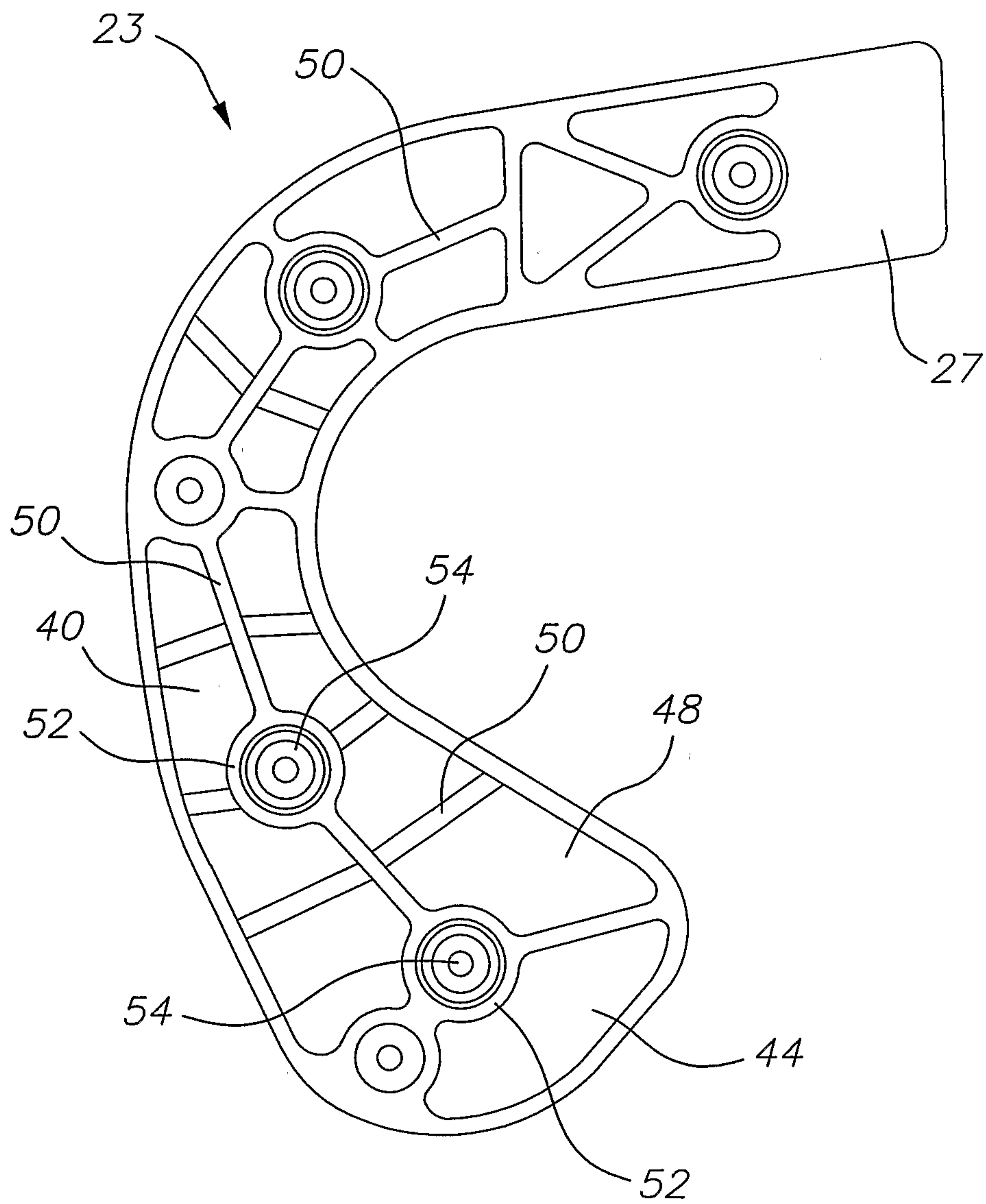

FIG. 4B

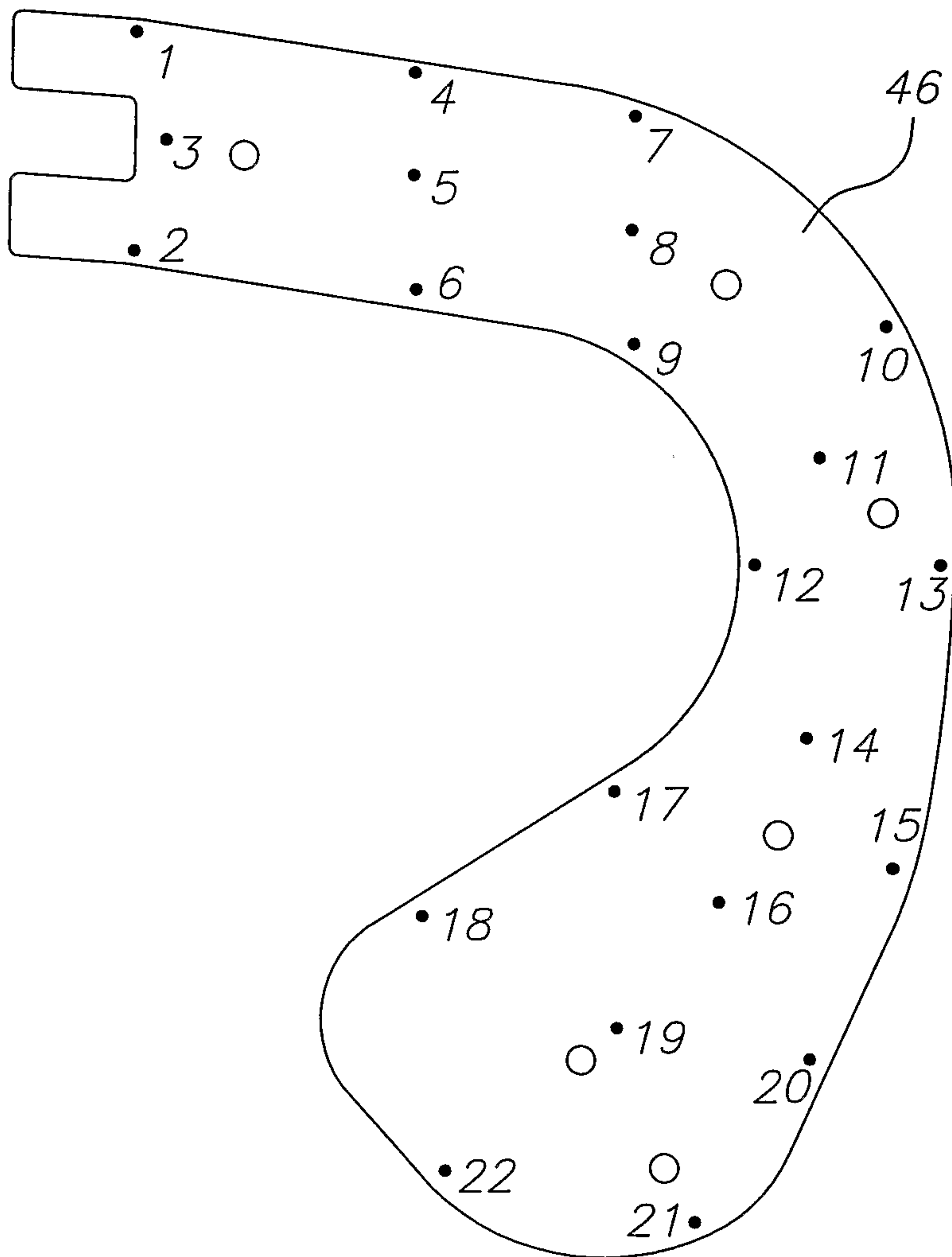

FIG. 5

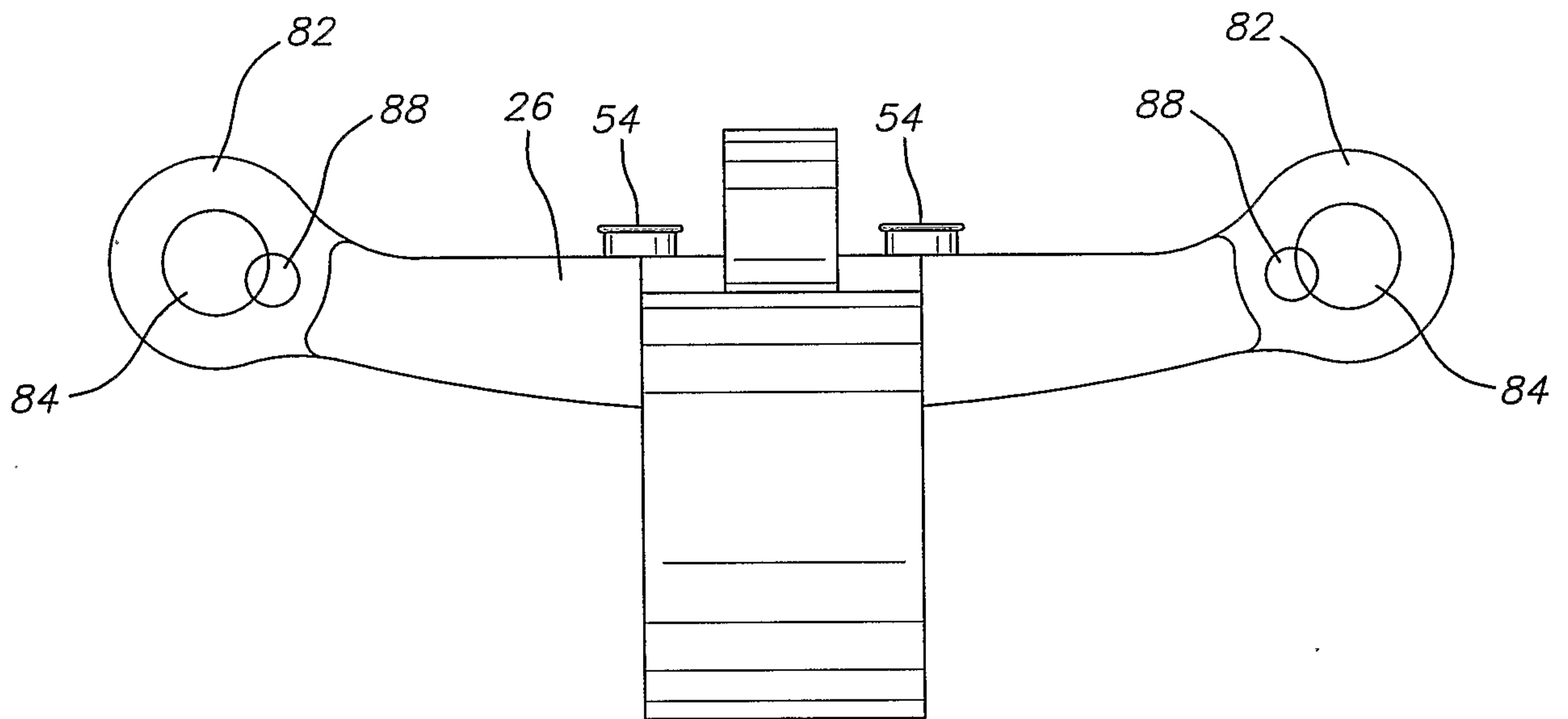

FIG. 6A

FIG. 6B

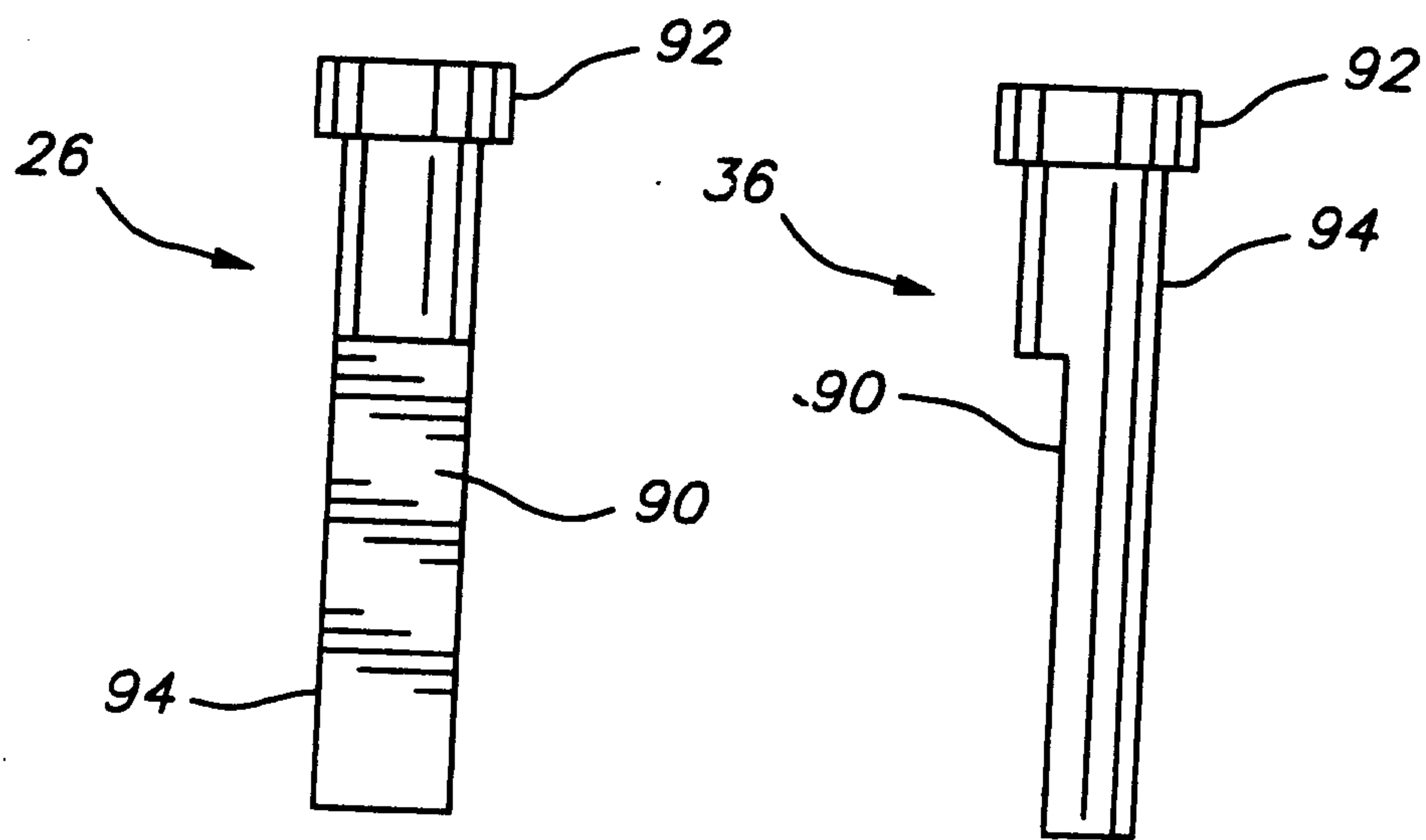

FIG. 7

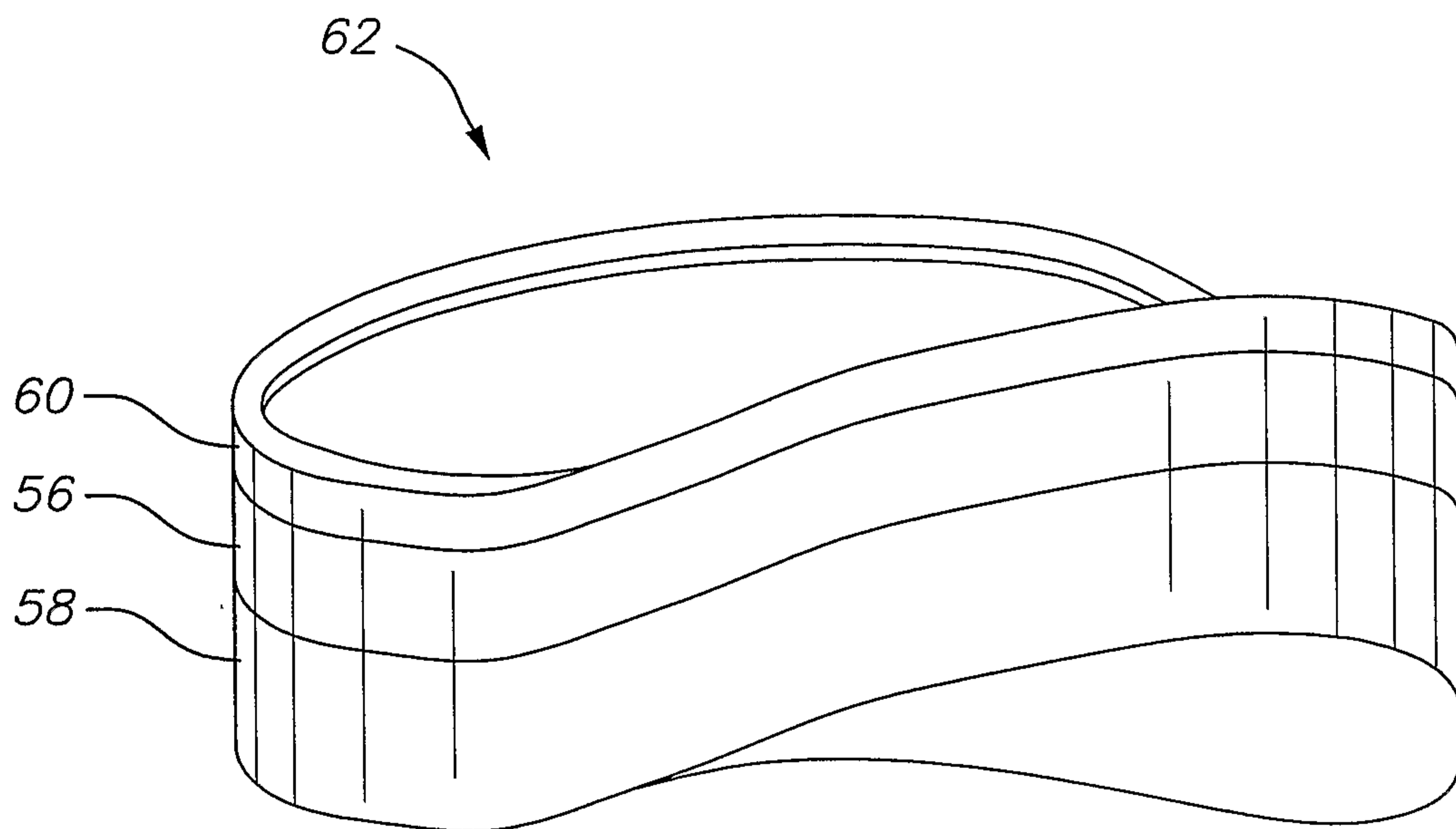

FIG. 8

