

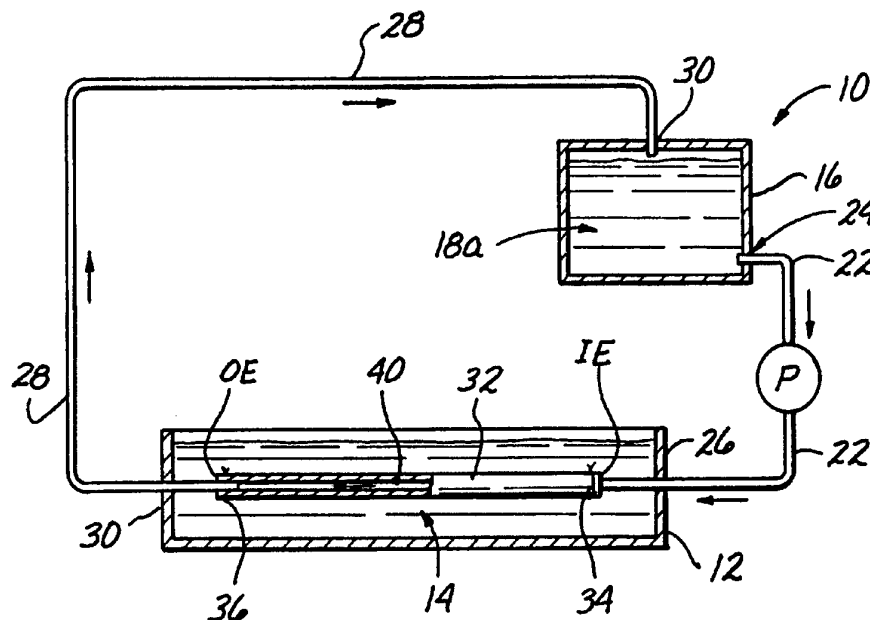

INTERNATIONAL APPLICATION PUBLISHED UNDER THE PATENT COOPERATION TREATY (PCT)

(51) International Patent Classification ⁵ : A61L 27/00	A1	(11) International Publication Number: WO 94/17841 (43) International Publication Date: 18 August 1994 (18.08.94)
<p>(21) International Application Number: PCT/US94/01012</p> <p>(22) International Filing Date: 28 January 1994 (28.01.94)</p> <p>(30) Priority Data: 08/011,609 1 February 1993 (01.02.93) US</p> <p>(71) Applicant: BAXTER INTERNATIONAL INC. [US/US]; One Baxter Parkway, Deerfield, IL 60015-4633 (US).</p> <p>(72) Inventors: TU, Roger; 2151 Palermo, Tustin, CA 92680 (US). WANG, Edwin; 13101 Cortina, Tustin, CA 92660 (US).</p> <p>(74) Agents: CONDINO, Debra, D. et al.; 2132 Michelson Drive, Irvine, CA 92715 (US).</p>	<p>(81) Designated States: CA, JP, European patent (AT, BE, CH, DE, DK, ES, FR, GB, GR, IE, IT, LU, MC, NL, PT, SE).</p> <p>Published <i>With international search report.</i></p>	

(54) Title: BIOLOGICAL GRAFTS HAVING REGIONALIZED DIFFERENCES IN CROSS-LINK DENSITY AND THEIR METHODS OF MANUFACTURE



(57) Abstract

Prosthetic tissue grafts formed of chemically cross-linked collagenous material wherein a first region of the graft (32) is cross-linked to a first cross-link density and a second region of the graft (32) is cross-linked to a second cross-link density. The desired regionalized variations in cross-link density of the collagenous graft (32) may be accomplished by exposing specific portions or regions of the graft (32) to different fixative compositions and/or fixative concentrations and/or fixative reaction conditions (e.g., pH, temperature, pressure, exposure time).

FOR THE PURPOSES OF INFORMATION ONLY

Codes used to identify States party to the PCT on the front pages of pamphlets publishing international applications under the PCT.

AT	Austria	GB	United Kingdom	MR	Mauritania
AU	Australia	GE	Georgia	MW	Malawi
BB	Barbados	GN	Guinea	NE	Niger
BE	Belgium	GR	Greece	NL	Netherlands
BF	Burkina Faso	HU	Hungary	NO	Norway
BG	Bulgaria	IE	Ireland	NZ	New Zealand
BJ	Benin	IT	Italy	PL	Poland
BR	Brazil	JP	Japan	PT	Portugal
BY	Belarus	KE	Kenya	RO	Romania
CA	Canada	KG	Kyrgystan	RU	Russian Federation
CF	Central African Republic	KP	Democratic People's Republic of Korea	SD	Sudan
CG	Congo	KR	Republic of Korea	SE	Sweden
CH	Switzerland	KZ	Kazakhstan	SI	Slovenia
CI	Côte d'Ivoire	LI	Liechtenstein	SK	Slovakia
CM	Cameroon	LK	Sri Lanka	SN	Senegal
CN	China	LU	Luxembourg	TD	Chad
CS	Czechoslovakia	LV	Latvia	TG	Togo
CZ	Czech Republic	MC	Monaco	TJ	Tajikistan
DE	Germany	MD	Republic of Moldova	TT	Trinidad and Tobago
DK	Denmark	MG	Madagascar	UA	Ukraine
ES	Spain	MN	Mali	US	United States of America
FI	Finland	ML	Mongolia	UZ	Uzbekistan
FR	France			VN	Viet Nam
GA	Gabon				

-1-

**BIOLOGICAL GRAFTS HAVING REGIONALIZED DIFFERENCES
IN CROSS LINK DENSITY AND THEIR METHODS OF MANUFACTURE**

5

Field of the Invention

The present invention relates generally to biological grafts, such as vascular prostheses, skin grafts, heart valves and the like. More particularly, the present invention relates to the preparation of collagenous graft materials having regionalized differences in cross link density to promote improved biocompatibility following implantation.

15

Background of the Invention

Various tissues of biological origin have been used for allogenic and xenogeneic grafting in human beings. For example, certain cardiovascular tissues (e.g., segments of blood vessels, heart valves) and integumentary tissues (e.g., skin grafts) may be harvested from human or other mammalian sources, subjected to one or more preservation treatments, and subsequently surgically implanted into, or grafted onto, the human body.

Tissue useable for allogenic or xenogeneic grafting may contain substantial amounts of connective tissue. Such connective tissue forms a supportive framework within which the functional cellular structure of the tissue is disposed. The flexibility or rigidity of the connective tissue framework depends largely on the proportions of collagen and elastin contained within such tissue and/or the structure and configuration of the collagen/elastin fiber network thereof.

Naturally occurring collagen molecules typically consist of three polypeptide chains intertwined in a coiled helical confirmation. The individual amino acid constituents of each polypeptide chain are connected, by

-2-

way of carbon bonds, to adjacent amino acids of a neighboring polypeptide chain. Such amino acid bonding holds the polypeptide chains in the triple helical confirmation of the collagen molecule.

5 Collagenous biological tissues may be termed or pressured for subsequent surgical grafting and/or implantation through a "fixing" process whereby the collagen network is exposed to one or more chemical compounds capable of cross linking the collagen molecules
10 to one another. Both intramolecular and intermolecular collagen cross linkages may be formed when the collagenous tissue is exposed to such collagen cross linking chemical fixative.

Chemical compounds which are known to be useable as
15 collagen cross linking fixatives include formaldehyde, glutaraldehyde, dialdehyde starch, hexamethylene diisocyanate and certain polyepoxy compounds including glycol diglycidyl ether, polyol polyglycidyl ether and dicarboxylic acid diglycidyl ester.

20 Three (3) specific water soluble polyepoxy compounds which may be used as collagen cross linking agents are shown below:

1. Difunctional epoxy

Ethylene glycol diglycidyl ether

25 (molecular weight = 270)

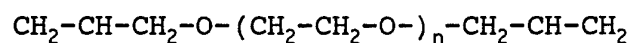

30 (wherein: n=1)

(Denacol[™] Ex-810; Nagase Chemicals, Ltd., Osaka, Japan)

35

-4-

the cross link density may be effected by other factors including a) the concentration of the fixative solution, b) the pH of the fixative solution, and c) physical conditions such as temperature and pressure.

5 The cross link density is generally correlated to the denaturation temperature of a cross linked collagenous material. In other words, a cross linked material with a higher denaturation temperature has a higher cross link density.

10 A fresh collagenous material has its baseline denaturation temperature (T_0). After treatment of this collagenous material with a cross linking fixative, its final denaturation temperature, which is higher than its baseline temperature, is determined as T_f . From prior
15 experiments, a maximum denaturation temperature for any given collagenous material was determined at T_m . The cross link density is therefore calculated as:

$$\text{Cross Link Density} = \frac{T_f - T_0}{T_m - T_0}$$

20 For example, a fresh bovine artery has its baseline denaturation temperature of 65°C. After contacting a 4% Denacol™ EX-313 glycerol polyglycidyl ether solution for 17 hours, the cross linked artery has a denaturation temperature of 80°C. From our previous experiments, the
25 maximum denaturation temperature of a bovine artery is about 85°C. Therefore, the cross link density is calculated as

$$\text{Cross link density} = (80^\circ\text{C} - 65^\circ\text{C}) / (85^\circ\text{C} - 65^\circ) = 75\%$$

30 One drawback associated with chemically cross linked collagenous biografts is that the residual chemical cross linking agent contained within the graft may adversely affect the biocompatibility and/or tissue affinity of the graft material. Prior investigators have attempted to deal with the problem of decreased biocompatibility by
35 neutralizing or deactivating any residual or unreacted cross linking agent within the graft through exposure of the graft to a second chemical solution capable of deactivating or neutralizing same residual unreacted

-5-

fixative (e.g., free aldehyde groups) within the biograft material. Examples of prior United States patents which describe methods whereby collagenous graft materials are treated with fixative deactivating or neutralizing chemical agents (e.g., amino acids) include U.S. Patent No. 3,974,526 (Dardik) entitled VASCULAR PROSTHESES AND PROCESS FOR PRODUCING THE SAME; U.S. Patent No. 3,988,782 (Dardik) entitled NON-ANTIGENIC, NON-THROMBOGENIC INFECTION-RESISTANT GRAFTS FROM UMBILICAL CORD VESSELS AND PROCESSES FOR PREPARING AND USING SAME and U.S. Patent No. 4,553,974 (Dewanjee) entitled TREATMENT OF COLLAGENOUS TISSUE WITH GLUTARALDEHYDE AND AMINODIPHOSPHONATE CALCIFICATION INHIBITOR.

In many applications, fixed biograft materials are implanted or grafted in a manner which results in direct contact between specific regions or portions of the graft and certain host tissues which are likely to give rise to problems with graft biocompatibility or graft-host reactions. The amount of fixative chemical present in a particular region, portion or surface of a graft may affect the bio-affinity of that portion or surface of the graft. In many applications sufficient bio-affinity is required to enable the tissue graft to undergo endothelialization either via blood stream regeneration or via in vitro endothelialization in a lab. For example, vascular grafts of biological origin are typically implanted to a host blood vessel by way of end-to-end anastomosis of such that blood will flow directly through the lumen of the graft. Thus, the ends of the vascular graft are typically in abutting contact with the adjacent ends of the host blood vessel. Also, the luminal surface of the graft is in intimate contact with the circulating blood of the host. Thus, the ends and luminal surface of such graft must have sufficient bio-affinity to undergo and maintain such direct host contact. The adventitial surface of the vascular graft is, however, subject to a lesser degree of contact with

-6-

the host tissue and, accordingly, may be able to tolerate a higher degree of residual fixative or higher cross link density than those portions of the graft which maintain direct or intimate contact with the neighboring host tissues.

Similarly, the periphery of a skin graft (e.g., permanent or temporary patch graft) may be sutured directly to or positioned adjacent the neighboring integumentary tissue and, as a result, graft-host reactions are most likely to occur at the suture line or interface between the graft tissue and the neighboring host integument. In contrast, however, the underside of the skin graft typically rests against subcutaneous adipose tissue which is comparatively unlikely to evoke an adverse graft-host reaction.

In other applications of skin grafts, the underside (i.e., body contacting surface) of the graft may be likely to evoke a graft-host reaction, or to impede healing of injured tissues underlying the graft. In such applications, the outer surface of the graft (i.e., non-body contacting surface) is less likely to evoke such graft-host reaction(s) and/or to impede healing of tissues which underlie the graft.

In view of the foregoing, there exists a need in the art for improved biograft materials having regionalized variations in fixative content and/or cross link density so as to accommodate the varying potential for graft-host reaction with surrounding host tissues.

Summary of the Invention

The present invention provides biological grafts formed of chemically cross linked collagenous material, wherein each graft comprises a) a first region wherein said collagen is cross linked to a first cross link density; and b) a second region wherein said collagen is cross linked to a second cross-link density different from said first cross link density.

-7-

The biological grafts of the present invention may be of any suitable mammalian origin (e.g., bovine, porcine, canine, human, etc. ...) and may be of any suitable shape or configuration including a) tubular
5 grafts (e.g., blood vessel, ureter, etc.,) b) flat or short-like grafts (e.g., skin grafts, pericardium) and/or c) functional anatomical structures (e.g., heart valves, venous valves, etc.).

Further in accordance with the invention there are
10 provided methods for preparing the collagenous grafts of the present invention whereby a first region of each graft is exposed to a first fixative agent under a first set of conditions (e.g., pH, temperature, pressure, exposure, time) to cause said first region to be cross
15 linked to said first cross link density and wherein said second region is exposed to a second set of conditions to cause said second region to be cross linked to said second cross link density different from said first cross link density.

20 Further in accordance with the invention, there are provided methods of preparing biological grafts of the present invention whereby separate regions of each graft are exposed to different fixative agents and/or different reaction conditions (e.g., pH, temperature, pressure,
25 time, etc.) to effect regionalized differences in cross link density of the graft.

Further objects and advantages of the present invention will become apparent to those skilled in the art upon reading and understanding of the following
30 detailed description and the accompanying drawings.

Brief Description of the Drawings

Figure 1 is a schematic diagram of a basic apparatus of the present invention whereby a segment of tubular
35 graft material is prepared for surgical implantation.

Figure 2a is a schematic showing of an alternative embodiment of an apparatus of the present invention.

-8-

Figure 2b is an enlarged perspective view of one solution feeder manifold component of the apparatus shown in Figure 2a.

Figure 2c is an enlarged view of portion 2c of
5 Figure 2a.

Figure 3a is a schematic showing of an alternative embodiment of an apparatus of the invention whereby a flat segment of biological graft material (eg., a skin graft) is prepared for subsequent surgical implantation.

Figure 3b is an exploded view of the bulkhead assembly portion of the apparatus shown in Figure 3a.

Figure 3c is a cross-sectional view through line 3c-3c of Figure 3a.

Figure 4a is a schematic showing of an alternative
15 embodiment of an apparatus of the present invention whereby a segment of tubular graft material (e.g., a blood vessel) is prepared for surgical implantation.

Figure 4b is an enlarged cross-sectional view of portion 4b of Figure 4a.

Figure 4c is an enlarged perspective view of one
20 graft mounting fixture of the apparatus shown in Figure 4a.

Detailed Description of the Preferred Embodiments

Figure 1 is a schematic showing of a basic apparatus
25 10 of the present invention. The apparatus 10 of Figure 1 is operable to fix tubular graft materials (e.g., blood vessel segments, segments of ureter, etc. ...) in accordance with the methods of the present invention.

The apparatus 10 shown in Figure 1 comprises a bath
30 chamber 12 wherein a quantity of a first fixative solution 14 is contained. The apparatus 10 further comprises a reservoir 16 wherein a quantity of a second fixative solution 18 is contained. A second fixative solution feed line 22 is inserted through an outlet port
35 24 near the bottom of reservoir 16. Feed line 22 extends through endwall 26 of bath 12. A fluid tight seal is formed by endwall 26, about the outer surface of inflow

-9-

tube 22, so as to prevent leakage around the inflow tube 22 at its point of insertion through endwall 26 and into reservoir 12. A pump P, such as a peristaltic pump, is positioned on feed line 22 to pump a flow of second
5 fixative solution 18 from reservoir 16, through feed line 22.

A return line 28 extends outwardly through endwall 30 of reservoir 12. Endwall 30 of reservoir 12 forms a fluid tight seal about the outer surface of return line
10 28 so as to avoid leakage around return line 28 at its point of emergence from reservoir 12. The opposite end of return line 28 is fluidly connected to inlet port 30 formed in the top of reservoir 16.

A segment of tubular graft material 32 (e.g., a cut
15 section of blood vessel) is submersed within the first fixative solution 14 contained within reservoir 12. The inflow end IE of tubular graft 32 is passed over the adjacent end of feed line 22 and secured thereon by way of ligature 34. The outflow end OE of tubular graft 32
20 is passed over the adjacent end of return line 28 and secured thereon by ligature 36.

By the above-described arrangement of the apparatus
10 shown in Figure 1, pump P may be operated through to continually or intermittently pump a flow of second
25 fixative solution 18 through the lumen 40 of tubular graft 32, while the adventitial surface of graft 32 remains directly exposed to the first fixative solution 14 contained within bath 12.

When it is desired to form a graft 32 having a lower
30 cross link density at its luminal surface than at its adventitial surface, the first fixative solution 14 within bath 12 will be of a higher concentration, higher reactivity, or otherwise maintained under conditions
(e.g., exposure time, pH, temperature, pressure) capable
35 of effecting a higher cross link density within the tissue of graft 32, than is the second solution 18 which passes through the lumen 40 of the graft 32. As such,

-10-

the adventitial surface of graft 32 will be coming in contact with first fixative solution 14 and will have a higher collagen cross link density than will the luminal surface of graft 32 coming in contact with second
5 fixative solution 18. Accordingly, the lower collagen cross link density of the luminal surface of the graft 32 will result in improved bio-compatibility or bio-affinity between the graft 32 and the blood subsequently
10 circulated therethrough. At the same time, the higher cross link density of the outer or adventitial portion of graft 32 will result in adequate fixation and preservation of the graft tissue so as to ensure that the graft 32 as a whole has been adequately preserved and will exhibit adequately shelf stability.

15 It will be appreciated that, although first and second fixative solutions of varying concentration may be utilized to bring about the desired regionalized variations in cross link density of the graft 32, various other conditions such as temperature and pressure, may
20 also be varied for purposes of controlling the relative cross link densities of regionalized portions of the graft, irrespective of whether the fixative solution(s) exposed thereto differ in concentration or chemical content.

Referring to Figure 2a, there is provided an
25 apparatus 10a of the present invention incorporating flow-enhancing and temperature control elements to provide for controlled regionalized variations in cross link density of the graft material 32b. As shown, a heater 60 is operatively mounted on or connected to
30 reservoir 12a so as to warm the first fixative solution 14a contained within reservoir 12a. Such heater 60 may comprise an immersion type heater or positioned within the reservoir 12a or may comprise an externally mounted heater positioned outside the reservoir and fluidly
35 connected thereto such that the first fixative solution 14a may be circulated therethrough. In embodiments utilizing an externally mounted heating element 60, a

-11-

pump may be incorporated within or utilized in connection with the heater 60 so as to pump the first fixative solution 14a through heater 60. Heater 60 is preferably provided with a thermostat mechanism operative to provide
5 continuous control of the temperature of the first fixative solution 14a within bath 12a.

Also, in the embodiment shown in Figure 2a, the reservoir 16a wherein the second fixative solution 18a is contained may be positioned on a height-adjustable jack
10 stand 62 such that the height of the fluid level within reservoir 16a may be adjusted relative to the heights of other components of the apparatus 10a. Additionally, first and second vestibular chambers 64, 66 are positioned adjacent opposite endwalls 26a, 30a of bath
15 12a. The first vestibular chamber 64 is positioned at a higher level than the second vestibular chamber 66 so as to cause gravity enhanced continuity of flow through the lumen of graft 32a.

A primary feed tube 22a fluidly connects the outlet
20 port 24a of reservoir 16a to the interior of first vestibular chamber 64. A secondary feed tube 68 extends from the interior of first vestibular chamber 64, through endwall 26a and into the interior of bath 12a. Similarly, a primary return tube 28 fluidly connects the
25 second vestibular chamber 66 to the inlet 30a of reservoir 16a, while a secondary return line 70 extends from the interior of second vestibular chamber 66, through endwall 30a and into the interior of bath 12a.

Accordingly, in the embodiment shown in Figure 2a,
30 the inlet and i.e., of graft 32a is affixed, by ligature, 34a, to the adjacent end of secondary feed tube 68, while the outflow end OE of graft 32a is affixed by ligature 36a to the adjacent end of secondary outflow tube 70.

Figure 2c is an enlarged view of a preferred
35 connector whereby one of the ends of the graft 32, 32a may be operatively connected to the adjacent primary or secondary feed 22, 28 or return 68, 70 tubing. In the

-12-

particular embodiment shown in Figure 2c, the outflow end OE of a tubular graft 32a is passed over a male Leur connector 72 and secured thereon by way of ligature 36a. Secondary return tube 70 is fluidly connected to a female
5 Leur connector 74. The male Leur connector 72 may, thus, be easily connected to/disconnected from the female Leur connector 74, thereby facilitating placement and removal of the graft 32a within the apparatus 10a.

It will be appreciated that any apparatus of the
10 present invention may be designed to simultaneously treat a plurality or multiplicity of grafts, rather than one single graft as shown in Figures 1, 2a or 3a. For example, Figure 2b shows a modified vestibular chamber 64 designed for use with six(6) separate tubular grafts by
15 way of six(6) separate secondary feed tubes 68a-f extending therefrom. Similarly, the opposite end vestibular chamber 66 may also be equipped with six(6) separate secondary outflow tubes arranged directly across from, and in alignment with the six(6) secondary feeder
20 tubes 68a-f of vestibular chamber 66, so as to permit simultaneous mounting and treatment of six (6) tubular graft segments 32, 32a within the bath chamber 12a. Of course, the size and configuration of the apparatus may be further modified to simultaneously treat fewer or more
25 separate graft segments, as desired.

Figures 3a-3c show an alternative embodiment of an apparatus of the present invention designed for treatment of flat segments of graft material such as segments of pericardium or skin. This apparatus comprises a
30 container or bath chamber 80 having a bulkhead/graft mounting assembly 82 mounted therein. In the embodiment shown, the bath chamber 80 is formed in a generally rectangular box-like configuration, but may alternatively be configured in any other shapes or configurations
35 capable of performing the function of the bath chamber 80. Bulkhead/graft mounting fixture 82 is shown in exploded view in Figure 3b. The bulkhead/graft mounting

-13-

5 fixture 82 comprises a first bulkhead member 84 and a second bulkhead member 86. The first and second bulkhead members 84, 86 each have at least one aperture 88, 90 formed therein, said apertures 88, 90 being directly alignable, as shown. O-ring mounting grooves 92 (not shown) are formed on the inboard surfaces of the first and second bulkhead members 84, 86 around each aperture 88, 90. Directly alignable fastener receiving apertures 98 are formed in each first and second bulkhead member 10 84, 86 to permit passage therethrough of fastening members 100, such as screws or bolts to hold the first and second bulkhead members 84, 86 in close-spaced juxtaposition to one another as shown in Figure 3c. When so positioned, the first and second bulkhead members 84, 15 86 will exert inward pressure on washers or O-rings 94, 96, thereby compressing and holding the segment of flat graft material 102 in an operative position between apertures 88 and 90. The fully assembled bulkhead/graft mounting fixture 82 is then inserted downwardly such that 20 the lateral ends of the bulkhead/graft mounting fixture 82 are slideably received within opposing placement grooves or tracks 104, 106 formed in the inboard surfaces of the sidewalls of bath chamber 80.

25 A similar groove or other sealing member may be formed on the floor of the bath chamber 80 such that, when fully inserted, the bottom edge of the bulkhead/graft mounting fixture 82 will seal against the floor of the bath chamber 80. As such, the operatively positioned bulkhead/graft mounting fixture 82 forms a 30 fluid tight seal in combination with the sidewalls and floor of the bath chamber, thereby dividing the bath chamber into a first fluid chamber 108 and a second fluid chamber 110. First fixative solution 14b is placed in the first fluid chamber 108 and a second fixative 35 solution 18b is placed in the second fluid chamber 110. As such, the one side of the graft 102 is exposed to the first fixative solution 14b while the opposite side of

-14-

the graft 102 is exposed to the second fixative solution 18b. By varying the chemical content, concentration, temperature and/or reaction conditions of the first fixative solution 14b relative to the second fixative solution 18b, cross-link densities of the right and left sides of the graft 102 may be varied independently of one another. As a result, there is provided a flat segment of graft material 102 having a first cross-link density on one side thereof, and a second cross link density on the other side thereof.

The present invention may also be employed to produce elongate or tubular grafts 202 having different cross-link densities at their ends, than in the mid-regions thereof. For example, Figures 4a-c show an alternative embodiment 200 of the present invention operative to prepare a segment of tubular graft material 202 such that the mid-region MR of the graft 202 is exposed to a first fixative solution 14c, while at least the adventitial and luminal surfaces of the lateral ends LE of the graft segment 202 are exposed to a second fixative solution 18c. As such, the cross link densities of the lateral ends LE of the graft 202 may be higher, lower or independently different from the cross link density of the mid-region MR of the graft 202.

As shown, the apparatus 200 shown in Figures 4a-4c comprises a main bath chamber 204 having first 106 and second 108 segmented bulkheads positioned therein, as shown, to divide the main bath chamber 204 into a middle bath chamber 208 and right and left lateral end chambers 210R and 210L. The segmented bulkheads 106, 108 form fluid tight seals about the adventitial surface of graft 202 to prevent leakage from the middle bath chamber 208 into the lateral end bath chambers 210R or 210L and vice versa.

A feed tube 214 fluidly connects outlet port 216 of reservoir 212 to the inflow end i.e., of the lumen of graft 202. A return tube 218 fluidly connects the

-15-

outflow end OE of the lumen of graft 202 to the return inlet port 220 of reservoir 212. Pump P may thus be operated to continually or intermittently pump a flow of first fixative solution 14c from reservoir 212, through
5 the lumen of at least the mid-region MR of graft 202.

By the apparatus 200 shown in Figure 4a, the adventitial (outer) and luminal (inner) surfaces of the mid-region MR of graft 202 are simultaneously exposed to the first fixative solution 14c contained in the middle
10 bath chamber 208 and circulating from reservoir 14c. The lateral end portions of IE and OE of the graft are exposed to the second fixative solution 18c contained in the lateral end bath chambers 210R and 210L.

In this embodiment, it will typically be desirable
15 that the cross link density of the lateral ends of the graft be lower than that of its mid-region. Accordingly, the concentration, chemical content, exposure time and/or conditions of second fixative solution 18c may differ from that of the first solution 14c, so as to result in
20 a lower cross link density at the lateral ends IE, OE, than that which results from exposure of the mid-region MR of the graft 202 to the first fixative solution 14c.

In embodiments of the invention such as the apparatus 200 shown in Figure 4a, it may be desirable to
25 permit the second fixative solution 18c to directly contact the luminal (inner) surfaces of the graft lying outboard of the bulkheads 106 and 108. If the ends of the graft 200 fit snugly over the outer surface of feed tube 214 and return tube 216, such may prevent the second
30 fixative solution 18c from so contacting the luminal (inner) surfaces of the ends of the graft 202. Accordingly, Figures 4b and 4c show means by which the lateral ends OE and IE of the graft 202 may be pulled away from the outer surfaces of feed tube 214 and return
35 tube 216 so as to permit the second fixative solution 18c to contact not only the adventitial (outer) surface and cut end of the graft, but also that portion of the

-16-

luminal (inner) surface of the graft which lies outboard of the bulkheads 106, 108.

As shown in Figure 4c, the ends of the feed tube 214 and return tube 216 may be provided with raised lifting members 220 such as beads or ridges formed on the outer surface of tubes 214 and 216. Such lifting members 220 will be sized, configured and positioned to hold the lateral ends OE and IE of graft 202 a spaced distance apart from the outer surface of tubes 214 and 216 so as to allow the second fixative solution 18c contained within lateral end chambers 210R 210L to contact those portions of the luminal surface of the graft 202 which extends outboard of bulkheads 106, 108. Additionally, an enlarged rim 222 may be formed about the ends of feed tube 214 and/or return tube 216 with a corresponding depression or groove 224 being formed in bulkheads 106, 108. Receiving groove 224 is sized relative to the raised rim 222 such that, when the end of tube 214 or 216 is seated within the raised groove 224 of bulkhead 106 or 108, the wall of graft 202 will be tightly compressed or held between rim 222 and the surrounding annular groove 224, so as to thereby form a fluid tight seal therebetween.

In routine operation of apparatus 200, pump P is energized to pump first fixative solution 14c through the lumen of graft 202. The luminal and adventitial surfaces of the mid-region MR of graft 202 are thereby simultaneously treated with the first fixative solution 14c, while the lateral ends OE and IE of graft 202 are treated with the second fixative solution 18c.

In the above-mentioned detailed description of the preferred embodiments, the first fixative solution may contain a second active ingredient such as aspirin, heparin or antibiotic agent so as to cause the tissue surface of reduced cross link density having an additional therapeutical capability.

-17-

Example 1**Preparation of a Vascular Graft Having a Luminal Surface of Reduced Cross link Density**

The following example is described with reference to the apparatus 10a shown in Figure 2a. However, it will be appreciated that reference to the apparatus 10b shown in Figure 2a is for purposes of description only. Indeed, the methodology of the following example may be practiced using apparatus other than that shown in Figure 2a.

A segment of mammalian blood vessel (e.g., bovine coronary artery) is removed from a donor animal and cut to a desired length. The segment of blood vessel is thoroughly cleaned with sterile saline solution and excess surrounding connective tissue is trimmed away. Any unwanted branches of the artery are ligated through the use of standard surgical technique and surgical suture materials.

After the above-described cleaning, trimming and ligation procedures have been completed, the outflow end OE of the blood vessel graft 32a is advanced over the end of secondary outflow tube 70 and a ligature 36a is applied to firmly hold the outflow end OE of graft 32a thereon. Similarly, the inflow end IE of graft 32a is advanced over the adjacent end of secondary feed tube 68 and ligature 34a is applied to hold the inflow end IE of graft 32a on the secondary feed tube 68.

In the example, the first fixative solution 14a consists of a 4% aqueous solution of Denacol™ EX-313 glycerol polyglycidyl ether (Nagase Chemicals, Ltd.). Such 4% Denacol™ EX-313 solution is placed in bath 12a and heating apparatus 60 is set to maintain a bath temperature of approximately 37° C. The level of the 4% Denacol™ EX-313 solution within bath 12a is maintained at sufficient height to ensure that the entire adventitial surface of the graft 32a remains submersed in or covered by the 4% Denacol™ EX-313 solution.

-18-

In this example, the second fixative solution 18a consists of an 0.5% aqueous solution of Denacol™ EX-313. Such 0.5% Denacol™ EX-313 solution is placed in reservoir 16a and vestibular chambers 64 and 66. Pump P is
5 operated to maintain a continuous flow of the 0.5% Denacol™ EX-313 solution through the lumen of graft 32a.

The temperature of the 0.5% Denacol™ EX-313 solution is monitored by temperature indicator 31 and, in this example, is maintained at approximately room temperature.

10 After the lumen of graft 32a has been exposed to the 0.5% Denacol™ EX-313 solution for sufficient time to bring about the desired cross link (typically 10-70% and probably 20-60%) density on the luminal surface of the graft, the 0.5% Denacol™ EX-313 solution may be removed
15 and replaced with 0.9% saline or other relatively inert liquid so as to halt the cross linking reaction. The saline solution or other inert liquid is then circulated through the lumen of graft 32a by pump P for the remainder of the treatment. Such inert liquid further
20 serves to keep the luminal surface of the graft well hydrated, without promoting further cross linking thereof. This inert liquid may contain anti-thrombotic agent (e.g., heparin), anti-coagulation agent (e.g., aspirin) or anti-biotic agent to deposit said therapeutic
25 agent onto the graft lumen. Pressure may be applied to enhance the deposition efficiency.

After the adventitial surface of the graft 32 has been exposed to the 4% Denacol™ EX-313 solution for sufficient time to cause the desired cross link density
30 of the adventitial surface (typically 50%-90% and preferably 70%-90%) ligatures 34a and 36a are removed and the graft 32a is extracted from the apparatus 10a. The fixed graft 32a is then washed and cut to its desired length and stored in a suitable medium (e.g., ethanol)
35 for subsequent surgical implantation.

-19-

Example 2**Preparation of a Skin Patch Graft Having a First Side of One Cross Link Density and a Second Side of Another Cross link Density**

5 The following example is described with particular reference to the apparatus shown in Figures 3a-3c. It will be appreciated, however, that the methodology of the following example may be practiced using various apparatus other than that shown in Figures 3a-3c.

10 A generally rectangular patch of mammalian skin (e.g., porcine skin) is surgically excised and harvested. The graft 102 is then washed and cleaned in accordance with standard pre-fixation techniques. O-rings 94-96 are positioned with O-ring receiving groups 92 and (not
15 shown) on the inner surfaces of 84 and 86. The graft 102 is positioned between O-rings 94 and 96 and screws 100 are passed through apertures 98 so as to securely fasten the right and left members 84-86 of bulkhead/graft mounting fixture 82 in juxtaposition, with pressure being
20 exerted by O-rings 94-96 against the outer surfaces of graft 102. Thereafter, the bulkhead/graft mounting fixture 82 is inserted downwardly in receiving tracks 104 of chamber 80. A first solution 14b consisting of 0.5% Denacol™ is based in the left chamber 108 of bath 80
25 while a second fixation solution 110 consisting of 0.5% aqueous glutaraldehyde is placed in the right chamber 110 of bath 80.

 Because glutaraldehyde is a fast-acting fixative, the right-side surface of graft 102 becomes substantially
30 fully cross linked (i.e., cross link density of 80-90%) in less than five seconds.

 The 0.5% Denacol™ solution contained in the left chamber 108 of bath 80 is, on the other hand, a slow acting fixative. Accordingly, the cross link density of
35 the left side of graft 102 may be controlled by the exposure time of the left-side surface of graft 102 to

-20-

the 0.5% Denacol™ EX-313 solution contained in the left chamber 108.

The exposure time of the 0.5% Denacol™ EX-313 to the left-side surface of graft 102 may be varied to effect a
5 desired degree of cross link density of graft 102. With this particular fixative, a 20-30% cross link density is typically believed to be non-antigenic and desirable. At room temperature, such 30% cross link density of the left- side of graft 102 may be achieved by exposure to
10 the 0.5% Denacol™ EX-313 for a period of approximately 5-10 hours.

After the desired exposure time has been completed, the bulkhead/graft mounting fixture 82 is removed from the apparatus 200. The bulkhead/graft mounting fixture
15 82 is then disassembled and the graft 102 is removed. Graft 102 is then washed, cut its desired size and shape, and stored in a suitable storage solution (e.g., ethanol) until surgical implantation.

20

Example 3

Preparation of Vascular Grafts Having Regionalized Variations in Cross link Density Using a Single Fixative Under Varied Conditions

25 The following example is described with reference to apparatus 10a shown in Figure 2a. Such reference to the apparatus 10a shown in Figure 2a is for purposes of description only and it will be appreciated that the methodology of the following example may be practiced
30 using apparatus other than that shown in Figure 2a.

A segment of mammalian blood vessel (e.g., bovine coronary artery) is removed from a donor animal and cut to a desired length. The segment of blood vessel is thoroughly cleaned with sterile saline solution and
35 excess surrounding connective tissue is trimmed away. Any unwanted branches of the artery are ligated through

-21-

the use of standard surgical technique and surgical suture materials.

Using the apparatus shown in Figure 2a, the outflow end OE of the blood vessel graft 32a is advanced over the end of the secondary outflow tube 70 and a ligature 36a is applied to from the outflow end OE of the graft 32a thereon. Similarly, the inflow end IE of graft 32a is advanced over the adjacent end of secondary feed tube 68 and ligature 34a is applied to hold the inflow and IE of graft 32a on the secondary feed tube 68.

In this example, the first 14a and second 18a fixative solutions consist of the same 4% aqueous solution of Denacol™ Ex-313 glycerol polyglycidyl ether (Nagase Chemicals, Ltd.). The first fixative solution 14a to which the adventitial surface of the graft 32a is maintained at a temperature from 20 to 50° C and preferably 25-45° C. The second fixative solution 18a to which the luminal surface of the graft 32a is subjected is maintained at a temperature less than that of the first solution to which the adventitial surface is subjected. For example, the temperature of the second fixative solution 18a to which the luminal surface of the graft 32a is subjected may be 20-50° C and preferably 25-40°C.

Thus, in this example, a single fixative solution is used under different temperatures to effect different cross link densities on the adventitial and luminal surfaces of a vascular graft.

30 Example 4

Preparation of Vascular Grafts Having Regionalized Differences in Cross link Density Using Differing Fixative Concentration and Differing Exposure Times

In this example, segments of bovine coronary artery are prepared and mounted in the device shown in Figure 2a in the manner described in Example 3 hereabove.

-22-

In this example, the first fixative solution 14a to which the adventitial surface of the graft 32a is subjected consists of 4% Denacol™ Ex-313 glycerol polyglycidyl ether (Nagase Chemicals, Ltd.) while the
 5 second fixative solution 18a to which the luminal surface of the graft 32a is subjected consists of 1% Denacol™ Ex-313 glycerol polyglycidyl ether solution.

In this example, both the first 14a(4% Denacol™ Ex-313) and second 18a(1% Denacol™ Ex-313) solutions are
 10 maintained at 37° C, and the exposure times for each solution are varied to effect the desired differences in cross link density between the luminal and adventitial surfaces of the graft 32a.

The effected cross link density of a region or
 15 surface of the graft may be measured in terms of denaturation temperature T_d . The following table shows the relative differences in cross link density, as represented by differences in T_d , of the luminal and adventitial surfaces of the graft 32d, as a function of
 20 exposure time:

Exposure Time (hr)	Luminal Surface (1% Denacol™ Ex-313)	Adventitial Surface (4% Denacol™ Ex-313)
3 hr.	$T_d = 67^\circ\text{C}$	$T_d = 73^\circ\text{C}$
6 hr.	$T_d = 71^\circ\text{C}$	$T_d = 77^\circ\text{C}$
17 hr.	$T_d = 74^\circ\text{C}$	$T_d = 80^\circ\text{C}$

The foregoing examples illustrate only four(4) specific methodological applications of the present
 30 invention. It will be appreciated that various other examples may be shown whereby the method of the present invention is utilized through variation of fixative type, fixative molecular size, fixative solution concentration, fixative temperature, pressure, and time.

-23-

Accordingly, it is appreciated that those skilled in the art will identify numerous modifications, alterations and/or additions to the herein described embodiments and examples of the invention. It is intended that all such
5 additions, modifications and alterations be included within the scope of the following claims and/or the equivalents thereof.

-24-

WHAT IS CLAIMED IS:

1. A prosthetic tissue graft formed of chemically cross linked collagenous material, said graft comprising:
 - 5 a. a first region of said graft wherein said collagen is cross linked to a first cross link density; and
 - b. a second region of said graft wherein said collagen is cross linked to a second cross link density, different from said first cross link
10 density.
2. The graft of Claim 1 wherein said graft comprises a segment of tubular collagenous material.
3. The graft of Claim 2 wherein said tubular collagenous material comprises a segment of blood vessel.
- 15 4. The graft of Claim 2 wherein said tubular collagenous material comprises a segment of artery.
5. The graft of Claim 2 wherein said tubular collagenous material comprises a segment of vein.
6. The graft of Claim 1 wherein said collagenous
20 material is cross linked by a polyepoxy compound.
7. The graft of Claim 6 wherein said polyepoxy compound is selected from the group consisting of:
 - a. ethylene glycol diglycidyl ether;
 - b. glycerol triglycidyl ether;
 - 25 c. sorbitol tetraglycidyl ether; and
 - d. the possible combinations thereof.
8. The graft of Claim 1 wherein said graft comprises a flat segment of collagenous tissue.
9. The graft of Claim 8 wherein said flat segment of
30 tissue comprises a skin graft.
10. The graft of Claim 8 wherein said flat segment of tissue comprises a pericardial graft.
11. The graft of Claim 1 wherein said first region has a cross link density of 10-70% and said second region has
35 a cross link density of approximately 50-90%.
12. The graft of Claim 1 wherein said collagen cross linking compound is a polyepoxy fixative and wherein said

-25-

first region has a cross link density of 10-70% and said second region has a cross link density of 50-95%.

13. The graft of Claim 1 wherein said collagen cross linking compound is a polyepoxy fixative and wherein said
5 first region has a cross link density of approximately 20-60% and wherein said second region has a cross link density of approximately 70-90%.

14. The graft of Claim 1 wherein said graft comprises a segment of blood vessel and wherein said first region
10 comprises the luminal surface of said blood vessel and wherein said second region comprises the adventitial surface of said blood vessel.

15. The graft of Claim 14 wherein the cross link density of said luminal surface of said blood vessel is
15 approximately 10-70% and wherein the cross link density of said adventitial surface of said blood vessel is approximately 50-95%.

16. The graft of Claim 15 wherein the cross link density of said luminal surface of said blood vessel is
20 approximately 20-60% and wherein the cross link density of said adventitial surface of said blood vessel is approximately 70-95%.

17. A method of preparing a collagenous graft having a first region of a first cross link density and a second
25 region of a second cross link density different from said first cross link density, said method comprising the steps of:

- a. providing a graft of collagenous material;
- b. exposing a first region of said graft to a
30 first collagen cross linking agent under a first set of conditions effective to cause said first region of said graft to be cross linked to a first cross link density; and
- c. exposing a second region of said graft to a
35 second collagen cross linking agent under a second set of conditions effective to cause said second region of said graft to be cross linked to a second

-26-

cross link density, different from said first cross link density.

18. The method of Claim 17 wherein the chemical composition of said first cross linking agent is
5 different from that of said second cross linking agent.

19. The method of Claim 17 wherein the chemical composition of said first cross linking agent is the same as that of said second cross linking agent.

20. The method of Claim 17 wherein, the chemical
10 composition of said first cross linking agent is the same as that of said second cross linking agent, but wherein said first and second cross linking agents are of different concentration so as to result in said differing first and second cross link densities of said first and
15 second regions, respectively.

21. The method of Claim 17 wherein said first cross linking agent is selected from the group consisting of:

- a. ethylene glycol diglycidyl ether;
- b. glycerol triglycidyl ether;
- 20 c. sorbitol tetraglycidyl ether; and
- d. the possible combinations thereof.

22. The method of Claim 17 wherein said second cross linking agent is selected from the group consisting of:

- a. ethylene glycol diglycidyl ether;
- 25 b. glycerol triglycidyl ether;
- c. sorbitol tetraglycidyl ether; and
- d. the possible combinations thereof.

23. The method of Claim 17 wherein the pH of said first cross linking agent is different from the pH of said
30 second cross linking agent so as to effect said first and second cross-link densities of said first and second regions, respectively.

24. The method of Claim 17 said first cross linking agent is at a first temperature and wherein said second
35 cross linking agent is at a second temperature, different from said first temperature so as to effect said

-27-

differing first and second cross link densities of said first and second regions, respectively.

25. The method of Claim 17 wherein said first region is exposed to said first cross linking agent for a first period of time and said second region is exposed to said second cross linking agent for a second period of time, different from said first period of time, so as to effect said differing first and second cross link densities of said first and second regions, respectively.

10 26. A method of preparing a vascular graft comprising a tubular segment of chemically cross linked collagenous material having an adventitial surface of a first cross link density and a luminal surface of a second cross link density, said second cross link density being different from said first cross link density, said method comprising the steps of:

- a) providing a graft of tubular collagenous material having an adventitial surface and a luminal surface;
- 20 b) exposing the luminal surface of said graft to a first cross linking agent for a first period of time under a first set of conditions to cause said luminal surface to be cross linked to said first cross link density; and
- 25 c) exposing the adventitial surface of said graft to a second cross linking agent for a second period of time under a second set of conditions to cause said adventitial surface to be cross linked to said second cross link density different from said first cross link density.

30 27. The method of Claim 26 wherein the chemical composition of said first cross linking agent is different from that of said second cross linking agent.

35 28. The method of Claim 26 wherein the chemical composition of said first cross linking agent is the same as that of said second cross linking agent.

-28-

29. The method of Claim 26 wherein, the chemical composition of said first cross linking agent is the same as that of said second cross linking agent, but wherein said first and second cross linking agents are of different concentration so as to result in said differing first and second cross link densities of said first and second regions, respectively.

30. The method of Claim 26 wherein said first cross linking agent is selected from the group consisting of:

- a. ethylene glycol diglycidyl ether;
- b. glycerol triglycidyl ether;
- c. sorbitol tetraglycidyl ether; and
- d. the possible combinations thereof.

31. The method of Claim 26 wherein said second cross linking agent is selected from the group consisting of:

- a. ethylene glycol diglycidyl ether;
- b. glycerol triglycidyl ether;
- c. sorbitol tetraglycidyl ether; and
- d. the possible combinations thereof.

32. The method of Claim 26 wherein the pH of said first cross linking agent is different from the pH of said second cross linking agent so as to effect said first and second cross-link densities of said first and second regions, respectively.

33. The method of Claim 26 said first cross linking agent is at a first temperature and wherein said second cross linking agent is at a second temperature, different from said first temperature, so as to effect said differing first and second cross link densities of said first and second regions, respectively.

34. The method of Claim 26 wherein said first region is exposed to said first cross linking agent for a first period of time and said second region is exposed to said second cross linking agent for a second period of time, said second period of time being different from said first period of time so as to effect said differing first

-29-

and second cross link densities of said first and second regions, respectively.

35. A method of preparing a vascular graft comprising a tubular segment of chemically cross linked collagenous material having first and second ends of a first cross link density and a mid-region between said first and second ends, said mid-region being of a second cross link density different from said first cross link density, said method comprising the steps of:
- 10 a. providing a segment of tubular collagenous material having first and second ends and a mid-region between said first and second ends;
 - b. exposing the first and second ends of said graft to a first cross linking agent for a first period of time under a first set of conditions to cause said first and second ends to be cross linked to said first cross link density; and
 - 15 c. exposing the mid-region of said graft to a second cross linking agent for a second period of time under a second set of conditions to cause said mid-region of said graft to be cross linked to said second cross link density.
- 20 36. The method of Claim 35 wherein the chemical composition of said first cross linking agent is different from that of said second cross linking agent.
- 25 37. The method of Claim 35 wherein the chemical composition of said first cross linking agent is the same as that of said second cross linking agent.
- 30 38. The method of Claim 35 wherein, the chemical composition of said first cross linking agent is the same as that of said second cross linking agent, but wherein said first and second cross linking agents are of different concentration so as to result in said differing first and second cross link densities of said first and second regions, respectively.
- 35 39. The method of Claim 35 wherein said first cross linking agent is selected from the group consisting of:

-30-

- a. ethylene glycol diglycidyl ether;
- b. glycerol triglycidyl ether;
- c. sorbitol tetraglycidyl ether; and
- d. the possible combinations thereof.

5 40. The method of Claim 35 wherein said second cross linking agent is selected from the group consisting of:

- a. ethylene glycol diglycidyl ether;
- b. glycerol triglycidyl ether;
- c. sorbitol tetraglycidyl ether; and
- 10 d. the possible combinations thereof.

41. The method of Claim 35 wherein the pH of said first cross linking agent is different from the pH of said second cross linking agent so as to effect said differing first and second cross-link densities of said first and second regions, respectively.

42. The method of Claim 35 said first cross linking agent is at a first temperature and wherein said second cross linking agent is at a second temperature, different from said first temperature, so as to effect said differing first and second cross link densities of said first and second regions, respectively.

43. The method of Claim 35 wherein said first region is exposed to said first cross linking agent for a first period of time and said second region is exposed to said second cross linking agent for a second period of time different from said first period of time so as to effect said first and second cross link densities of said first and second regions, respectively.

44. A method of preparing a graft comprising a sheet of chemically cross linked collagenous material having a first portion of a first cross link density and a second portion of a second cross link density said second cross link density being different from said first cross link density, said method comprising the steps of:

- 35 a. providing a graft of collagenous material having a first surface and a second surface;

-31-

b. exposing the first portion of said graft to a first cross linking agent for a first period of time under a first set of conditions to cause said first portion of said graft to be cross linked to said first cross link density; and

c. exposing the second portion of said graft to a second cross linking agent for a second period of time under a second set of conditions to cause said second portion of said graft to be cross linked to said second cross link density.

45. The method of Claim 44 wherein the chemical composition of said first cross linking agent is different from that of said second cross linking agent.

46. The method of Claim 44 wherein the chemical composition of said first cross linking agent is the same as that of said second cross linking agent.

47. The method of Claim 44 wherein, the chemical composition of said first cross linking agent is the same as that of said second cross linking agent, but wherein said first and second cross linking agents are of different concentration so as to result in said differing first and second cross link densities of said first and second portions, respectively.

48. The method of Claim 44 wherein said first cross linking agent is selected from the group consisting of:

- a. ethylene glycol diglycidyl ether;
- b. glycerol triglycidyl ether;
- c. sorbitol tetraglycidyl ether; and
- d. the possible combinations thereof.

49. The method of Claim 44 wherein said second cross linking agent is selected from the group consisting of:

- a. ethylene glycol diglycidyl ether;
- b. glycerol triglycidyl ether;
- c. sorbitol tetraglycidyl ether; and
- d. the possible combinations thereof.

50. The method of Claim 44 wherein the pH of said first cross linking agent is different from the pH of said

-32-

second cross linking agent so as to effect said first and second cross-link densities of said first and second regions, respectively.

51. The method of Claim 44 said first cross linking agent is at a first temperature and wherein said second cross linking agent is at a second temperature, said second temperature being different from said first temperature so as to effect said differing first and second cross link densities of said first and second portions, respectively.

52. The method of Claim 44 wherein said first region is exposed to said first cross linking agent for a first period of time and said second region is exposed to said second cross linking agent for a second period of time; said second period of time being different from said first period of time so as to effect said differing first and second cross link densities of said first and second portions, respectively.

53. The method of Claim 44 wherein said graft has an outer surface and an inner surface and wherein said first portion of said graft comprises the outer surface thereof and wherein said second portion of said graft comprises the inner surface thereof.

54. The method of Claim 44 wherein said graft has an outer periphery and a mid-region within said outer periphery and wherein said first portion comprises the outer periphery of said graft and said second portion comprises the mid-region of said graft.

55. In a graft comprising cross linked collagenous material, the improvement comprising:

a first portion of said graft being cross linked to a first cross link density and a second portion of said graft being cross linked to a second cross link density, said second cross link density being different from said first cross link density.

56. In a method of preparing a graft of chemically cross linked collagenous material wherein said method includes

-33-

the steps of exposing said graft to at least one chemical cross linking agent for purposes of cross linking the collagen within said graft, the improvement comprising:

- 5 a. exposing a first portion of said graft to a cross linking agent for a first period of time under a first set of conditions to cause said first portion of said graft to be cross linked to a first cross link density;
- 10 b. exposing a second portion of said graft to a cross linking agent for a second period of time under a second set of conditions to cause said second portion of said graft to be cross linked to a second cross link density; and
- 15 c. said second cross link density being different from said first cross link density.

Fig. 1

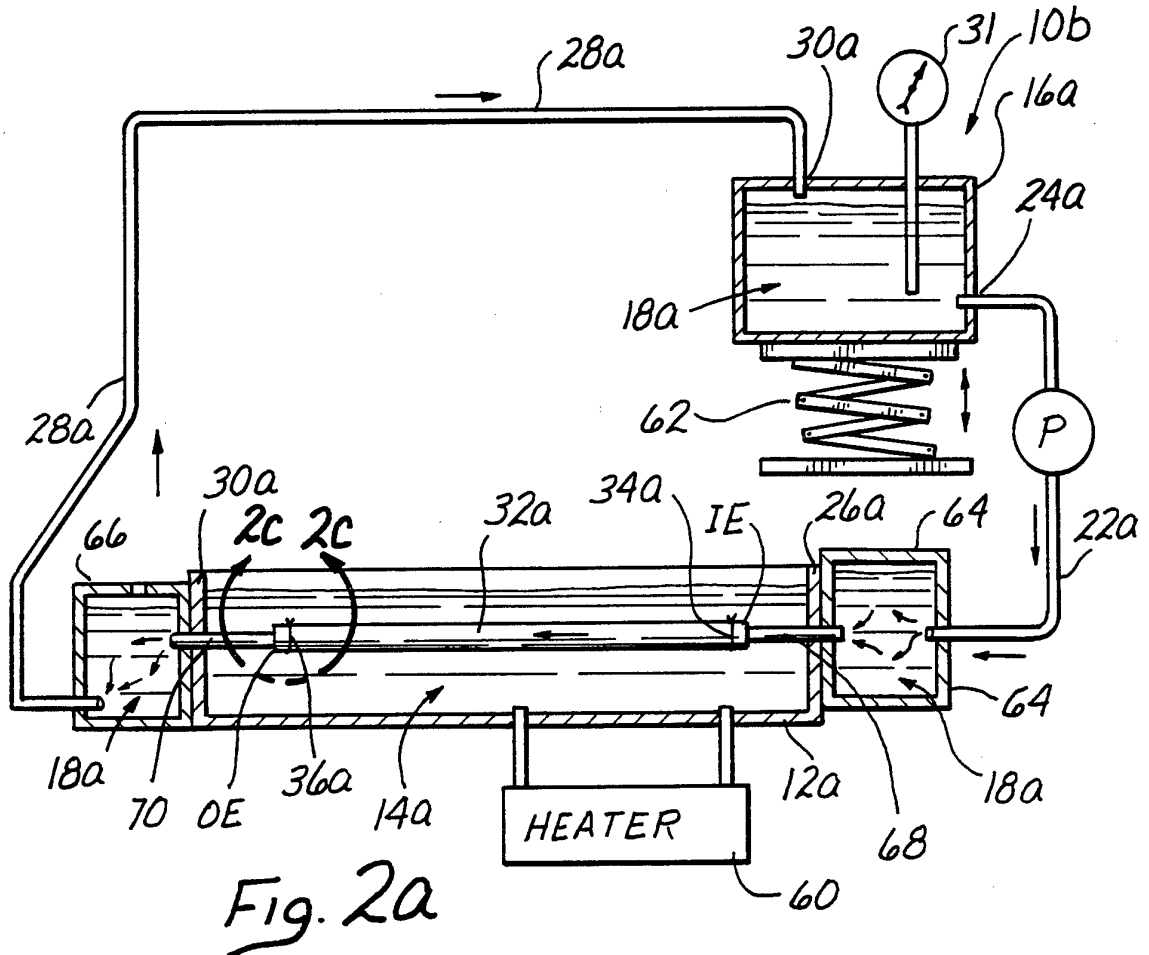
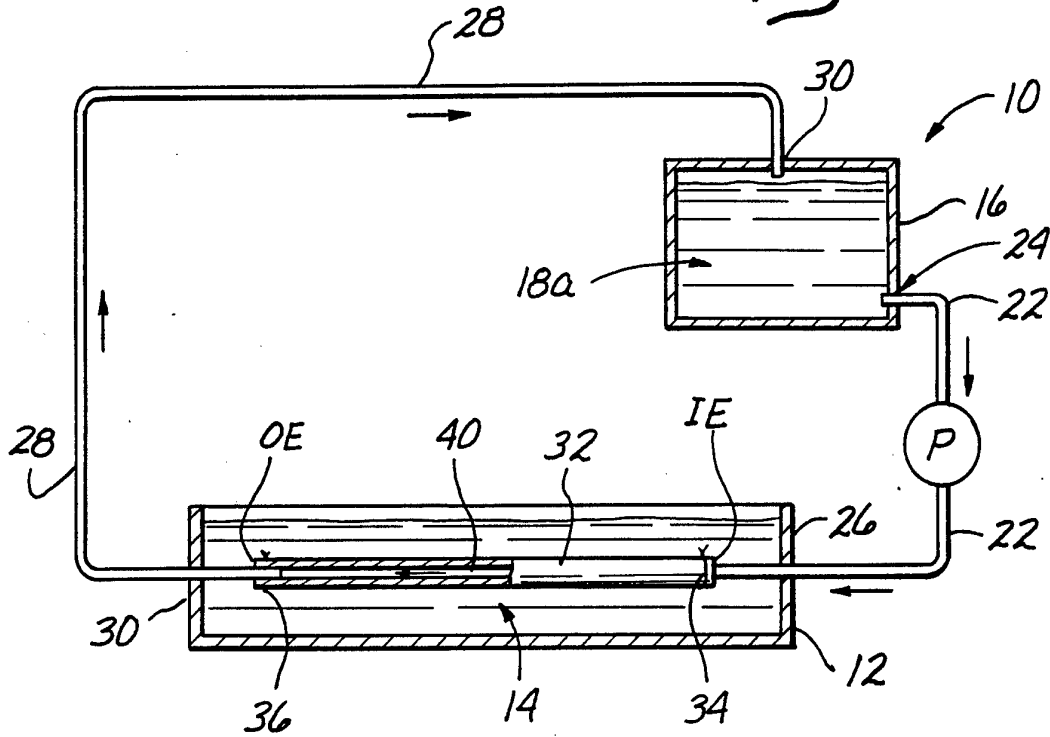

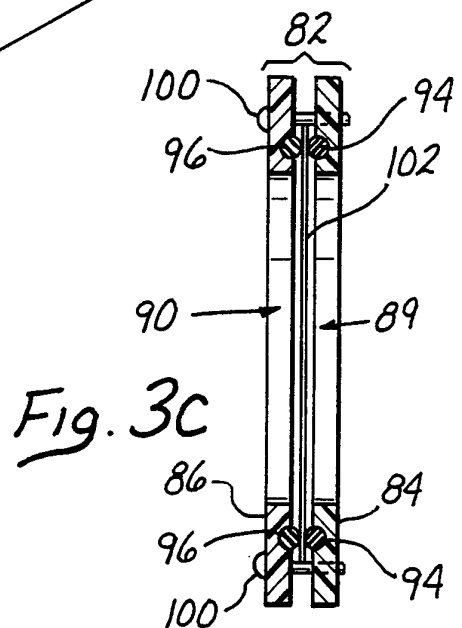
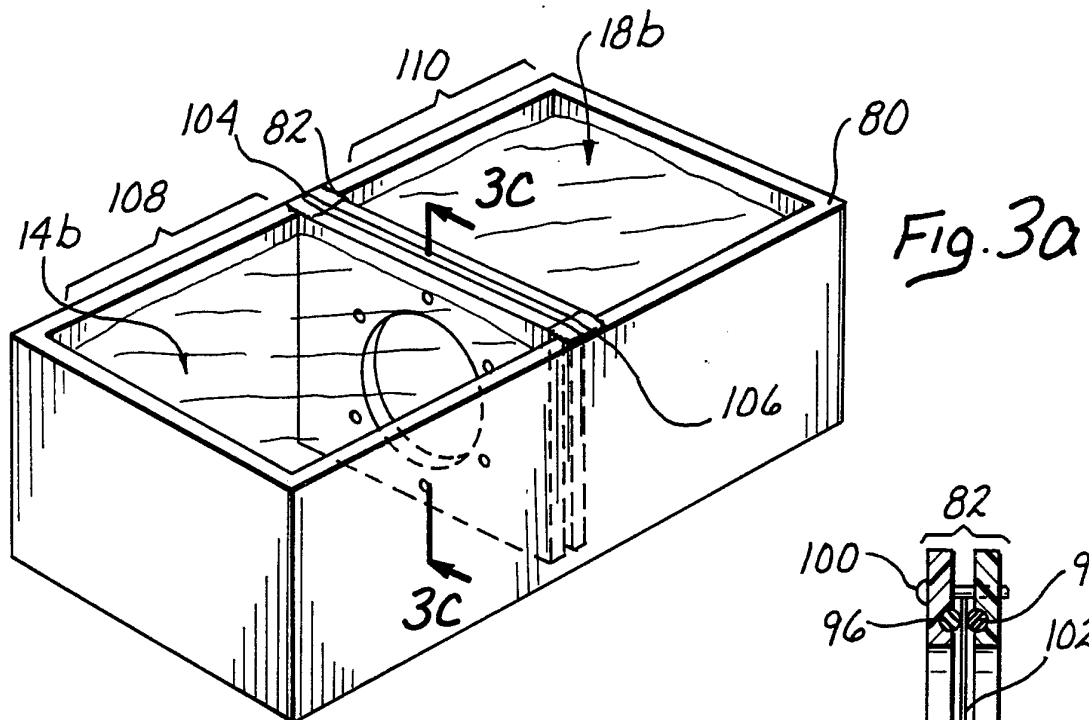
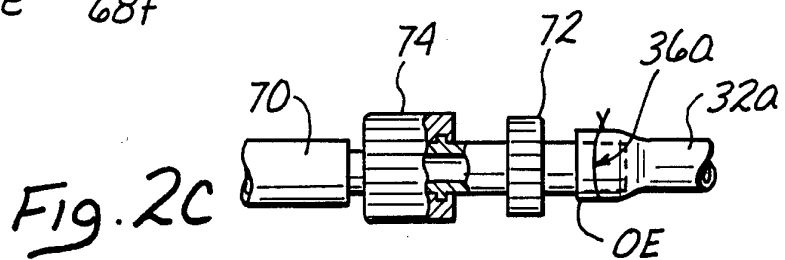
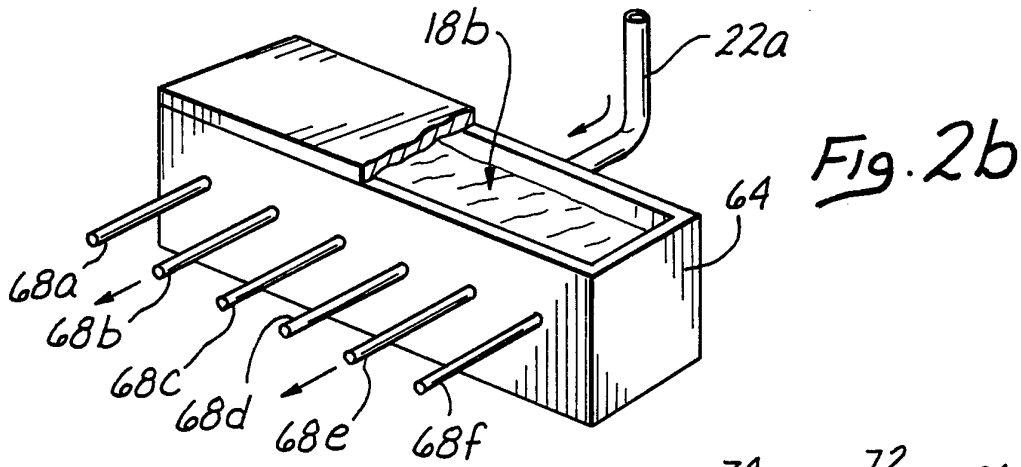

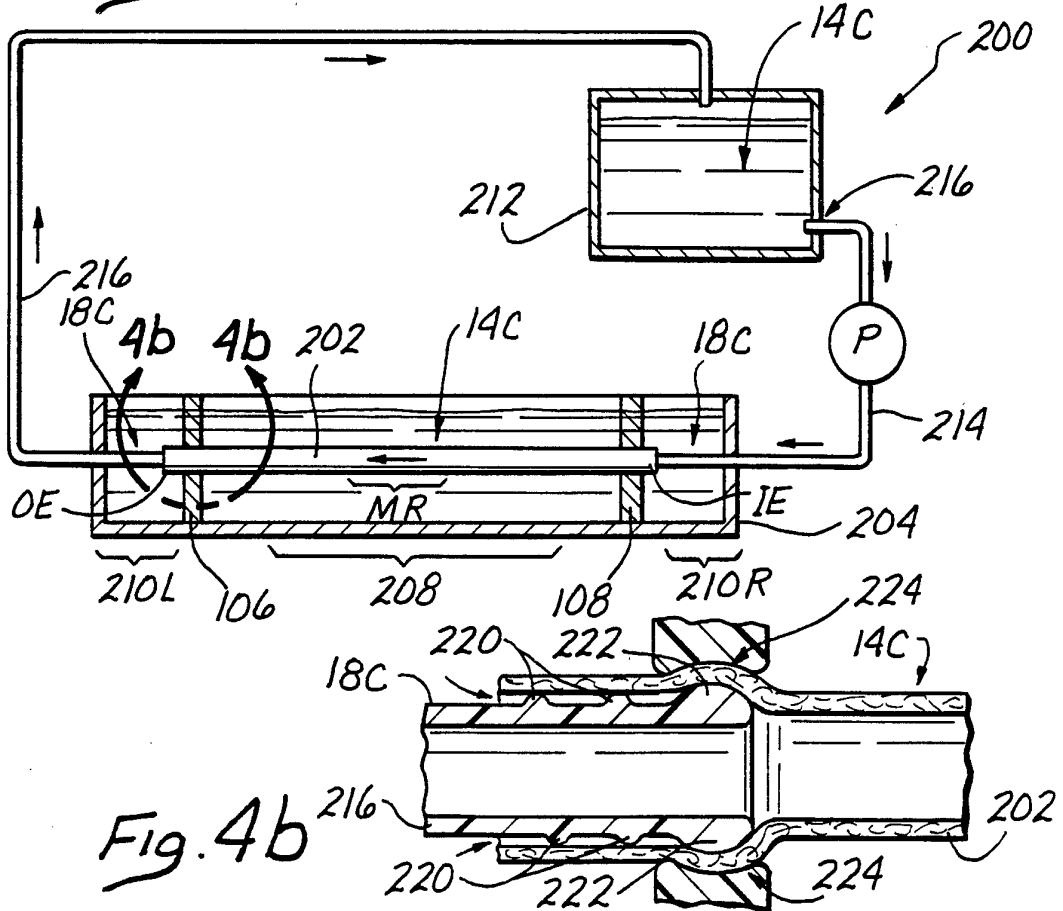
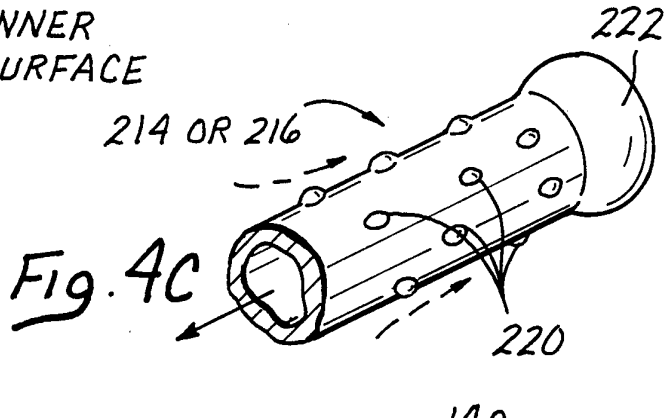
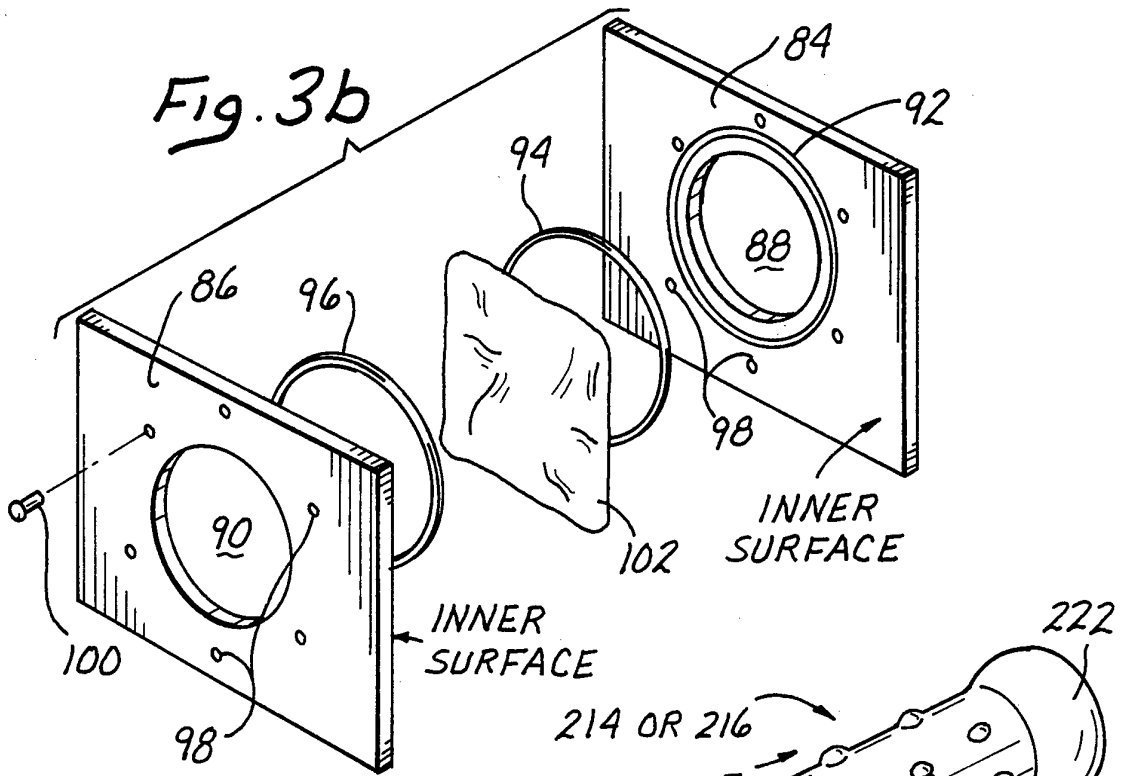

INTERNATIONAL SEARCH REPORT

International Application No
PCT/US 94/01012

A. CLASSIFICATION OF SUBJECT MATTER
IPC 5 A61L27/00

According to International Patent Classification (IPC) or to both national classification and IPC

B. FIELDS SEARCHED

Minimum documentation searched (classification system followed by classification symbols)
IPC 5 A61L

Documentation searched other than minimum documentation to the extent that such documents are included in the fields searched

Electronic data base consulted during the international search (name of data base and, where practical, search terms used)

C. DOCUMENTS CONSIDERED TO BE RELEVANT

Category *	Citation of document, with indication, where appropriate, of the relevant passages	Relevant to claim No.
X	WO,A,92 14419 (BAXTER INTERNATIONAL INC.) 3 September 1992 see claims; figures ---	1
A	EP,A,0 306 256 (KOKEN CO. LTD.) 8 March 1989 see the whole document ---	1-56
A	EP,A,0 311 305 (KOKEN COMPANY LTD.) 12 April 1989 see claims; example ---	1-56
A	EP,A,0 509 833 (KOKEN CO. LTD.) 21 October 1992 see page 3, line 30 - line 39; examples --- -/--	1

Further documents are listed in the continuation of box C. Patent family members are listed in annex.

* Special categories of cited documents :

"A" document defining the general state of the art which is not considered to be of particular relevance

"E" earlier document but published on or after the international filing date

"L" document which may throw doubts on priority claim(s) or which is cited to establish the publication date of another citation or other special reason (as specified)

"O" document referring to an oral disclosure, use, exhibition or other means

"P" document published prior to the international filing date but later than the priority date claimed

"T" later document published after the international filing date or priority date and not in conflict with the application but cited to understand the principle or theory underlying the invention

"X" document of particular relevance; the claimed invention cannot be considered novel or cannot be considered to involve an inventive step when the document is taken alone

"Y" document of particular relevance; the claimed invention cannot be considered to involve an inventive step when the document is combined with one or more other such documents, such combination being obvious to a person skilled in the art.

"&" document member of the same patent family

Date of the actual completion of the international search 4 May 1994	Date of mailing of the international search report 11.05.94
---	--

Name and mailing address of the ISA European Patent Office, P.B. 5818 Patentlaan 2 NL - 2280 HV Rijswijk Tel. (+31-70) 340-2040, Tx. 31 651 epo nl, Fax: (+31-70) 340-3016	Authorized officer ESPINOSA, M
--	---------------------------------------

INTERNATIONAL SEARCH REPORT

Inter national Application No
PCT/US 94/01012

C.(Continuation) DOCUMENTS CONSIDERED TO BE RELEVANT

Category *	Citation of document, with indication, where appropriate, of the relevant passages	Relevant to claim No.
A	ASAIO TRANSACTIONS vol. 38, no. 3 , September 1992 , TORONTO, CA pages 266 - 270 YUKIO ICHIKAWA 'A NEW RV-PA CONDUIT WITH A NATURAL VALVE MADE OF BOVINE JUGULAR VEIN.' see abstract -----	1

INTERNATIONAL SEARCH REPORT

Information on patent family members

International Application No

PCT/US 94/01012

Patent document cited in search report	Publication date	Patent family member(s)	Publication date
WO-A-9214419	03-09-92	EP-A- 0571527	01-12-93
EP-A-0306256	08-03-89	JP-A- 1058259 DE-D- 3888263 US-A- 5080670	06-03-89 14-04-94 14-01-92
EP-A-0311305	12-04-89	JP-A- 1091857 DE-A- 3874473	11-04-89 15-10-92
EP-A-0509833	21-10-92	JP-A- 4227265	17-08-92