

(No Model.)

M. WANNER.
REGENERATIVE FURNACE.

No. 517,991.

Patented Apr. 10, 1894.

FIG. 1.

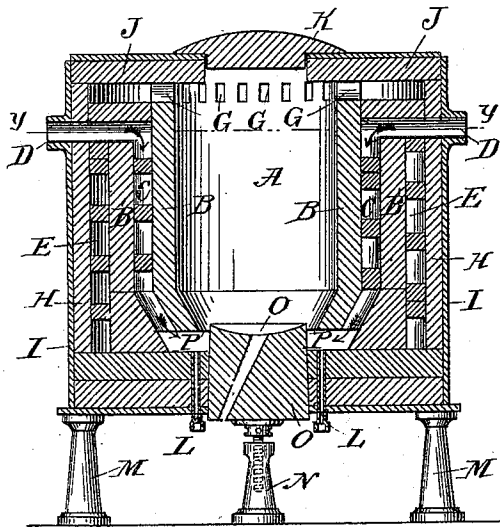

FIG. 4.

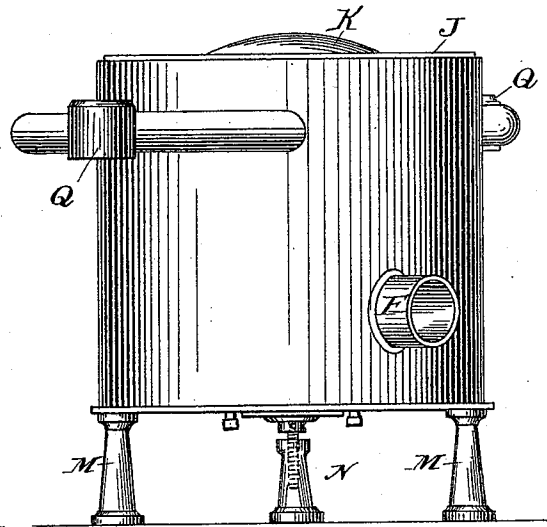

FIG. 2.

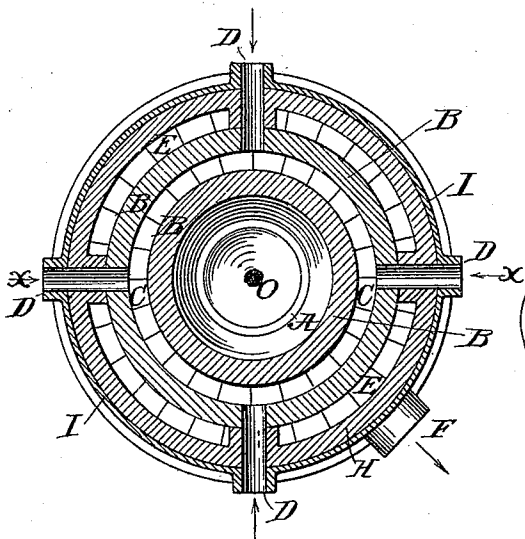
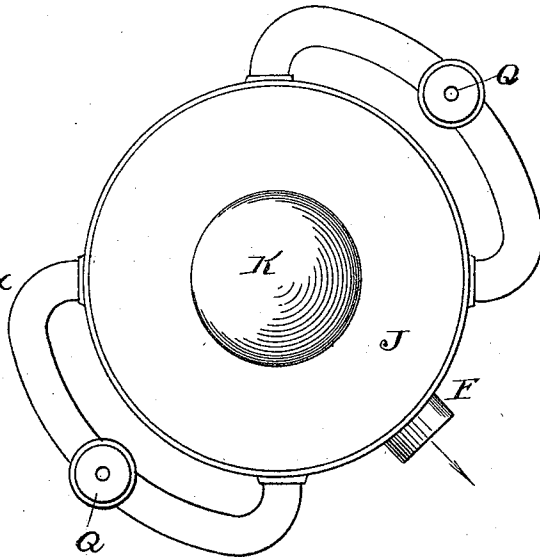

FIG. 3.



WITNESSES:

Edward C. Rowland.
John Lacey.

INVENTOR

Martin Wanner

BY

Phillips Abbott

ATTORNEY

UNITED STATES PATENT OFFICE.

MARTIN WANNER, OF DENVER, COLORADO, ASSIGNOR OF ELEVEN-TWENTYETHS TO WILLIAM B. CRITTENDEN AND JOHN M. MILLMAN, OF BUCYRUS, OHIO.

REGENERATIVE FURNACE.

SPECIFICATION forming part of Letters Patent No. 517,991, dated April 10, 1894.

Application filed December 8, 1892. Serial No. 454,457. (No model.)

To all whom it may concern:

Be it known that I, MARTIN WANNER, a citizen of the United States, and a resident of Denver, in the county of Arapahoe and State of Colorado, have invented certain new and useful Improvements in Regenerative Furnaces, of which the following is a specification.

My invention relates to improvements in regenerative furnaces, but before describing it a brief statement will be given of the results which I accomplish by my invention whereby it will be more readily understood and its advantages appreciated.

The improved furnace covered in and by this application is designed to do a variety of work from the remelting of lead, type-metal, or any other work requiring comparatively low temperatures, to the fusion of brass, copper, iron, &c., and the reduction of ores of all kinds requiring high temperatures. It is not intended for any specific purpose, nor is it exclusively a smelting furnace, but can be used not only for high and low temperature work as above stated, but also for the burning of brick, terra cotta or porcelain, simply by changing the hearth, which in my invention is easily effected because my hearth is made adjustable and may be set either high or low in the combustion chamber as the nature of the work to be performed requires. And also the position and composition of my hearth may be changed depending upon the different kinds of work which the furnace is to perform. Furthermore, by simply regulating the air inlet valves the nature of the flame may be instantly changed from oxidizing to neutral or reducing, or vice versa. This is one of the reasons why my furnace is capable of performing such a variety of work. For instance, supposing the furnace to be used for converting pig-iron, containing phosphorus into steel the adjustable hearth would be constructed out of material with which the phosphorus in the iron would combine, while an oxidizing flame would be used to remove excess of carbon. It is self-evident that the two processes may need exposures to the action of the oxidizing flame and to that of the hearth material for different periods of time,

consequently it becomes imperative that either the action of the hearth material or the action of the flame should be under the control of the operator, this is effected with the air inlet regulators or valves. Again, the vertical position of the hearth in the furnace also determines the action of the flame whether oxidizing or reducing. To illustrate: The hearth being placed near or about level with the entrance ports of the air and gas, the free carbon in the flame produces a reducing action, while if the hearth is more elevated, the free oxygen composing the outside of the flame, produces the oxidizing action on the material on the hearth.

In my furnace the gas and air currents intercept each other and are thoroughly mixed before entrance into the combustion chamber proper, and the air supply is regulated absolutely according to the amount of gas consumed and the nature of the flame required, by the air inlet regulating valves, and my construction aims to bring about as nearly as possible an even distribution of heat throughout the entire interior of the combustion chamber and I do not as in some other furnaces concentrate the maximum temperature at any certain point in the combustion chamber, the uniform distribution of the heat throughout the combustion chamber is desirable in any event, and for some of the operations which my furnace is capable of performing it is indispensable, and one of the special objects of my construction is to achieve that result. The spaces outside of the bridge wall and within the outside wall of my furnace are preferably not annular spaces but should more properly be called cellular brickwork forming checkers or staggers and are, preferably but not necessarily, bound into and form part of the solid brickwork, so that the whole of the furnace is one practically solid piece of masonry capable of working without any outside metallic casing.

The invention consists, broadly stated, in so constructing the furnace, that it shall have a bridge wall of refractory material, which entirely surrounds the sides of the combustion chamber, and outside of the bridge wall there is an annular chamber or chambers

which preferably but not necessarily surround the combustion chamber in which chamber or chambers, air is admitted from the outside, which in its passage to the combustion chamber becomes heated by radiation from the bridge wall, and also to a certain extent by contact with the outer shell thereof, and the products of combustion in my furnace are taken off at the upper portion of the combustion chamber and passing over the upper edge of the bridge wall and its outer shell are carried downward to the stack through another chamber or chambers which likewise preferably although not necessarily entirely surround the exterior sides of the outer shell of the bridge wall. In all of these chambers, *i. e.*, the ones in which the incoming air is heated, and those in which the products of combustion circulate on their way from the combustion chamber to the stack, I prefer to employ checkers, preferably staggered in their arrangement, which create eddies in the flow of both the air and the products of combustion, whereby the heat is better utilized in a manner well known.

Another feature of my invention is the ease with which the flame can be regulated or modified from an oxidizing to a reducing or neutral flame, or vice versa, by means of regulating valves which control the air inlets in conjunction with my peculiarly constructed hearth. The bridge wall is very considerably contracted or drawn together, at the lower end of the combustion chamber, *i. e.*, at the place where the incoming gas and air enter the combustion chamber, so that the expansion of these two elements, which results upon perfect ignition and combustion, does not and cannot take place excepting within the combustion chamber itself. I make the bottom of the combustion chamber or hearth separate and distinct from the rest of the structure, that is to say, I construct it of brick, clay, tile, or other refractory material and in such manner that it is not interlocked with, or dovetailed into, the adjacent structure of the furnace, but on the contrary so that it may be vertically adjusted relative to the combustion chamber and also easily removed when it is desired to modify either its shape or the composition of which its upper part is constructed. I support this independent bottom upon its own proper supports which can be removed without endangering the rest of the structure, and they are suitably made to secure the vertical adjustment mentioned.

In the drawings hereof:—Figure 1, is a vertical section of my furnace on the line *x, x*, of Fig. 2. Fig. 2, is a plan in section on the line *y, y*, of Fig. 1. Fig. 3, is a plan view of the furnace; Fig. 4, an elevation of the furnace.

A, is the combustion chamber.

B, is the bridge wall made of refractory material.

B' is an annular outer shell of the bridge wall; C is a space or chamber between the

said bridge wall and outer shell in which the incoming air which enters at D, D, &c., after passing through the air valve Q, Q, is heated.

E, is a chamber on the outside of the shell B' of the bridge wall, through which the products of combustion pass on their way to the stack, shown at F (see Figs. 2, 3 and 4).

G, G, are flues or openings in the upper part of the combustion chamber above the bridge wall as shown, through which the products of combustion pass from the combustion chamber to the space or chamber E. The flues G, G, are separate as shown so that the partitions between them may serve as supports for the superposed cover J.

H is an exterior wall whereby the chamber or chambers E, are formed.

I is a metallic shell, which I prefer to employ on the outside of all for additional protection.

J is a top for the structure upon which is supported the cover K.

L, L are suitable passages through which the gas enters which discharge at such points as to intercept the incoming hot air before entering the combustion chamber to insure their thorough mixture.

M, M, &c., are suitable legs or supports upon which the furnace proper rests: there may be as many of them as desired and of any preferred construction.

N is a central leg or support for the independent furnace bottom, O. This independent bottom, O, is as above stated made separate and distinct from the rest of the structure, and the leg or support, N, is directly beneath it and is so constructed that when desired to renew the furnace bottom, O, or to change its shape or composition, or to elevate or depress it, by proper manipulation of the leg or support the desired result may be readily attained. I illustrate the independent bottom as supported upon a removable iron leg provided with a screw which can be run up or down as desired. This is a good form of support but may be substituted by one of any other preferred construction.

It will be noticed that the lower portion of the bridge wall is contracted or drawn in forming the narrow opening or throat, as at P, P, so that the air which follows the direction indicated by the arrows meets the gas passing upwardly through the passages, L, L, by the side of the independent bottom in the narrow or contracted chambers or parts through which the hot air enters and below the combustion chamber, and that immediately above the contraction of the bottom of the combustion chamber the bridge wall flares or widens out again to the normal width of its interior, consequently there is provided immediately adjacent to the contracted throat, but within the combustion chamber, an enlargement of the space occupied by the gas and air, so that they have ample room within which to expand as complete combustion takes place and are not subjected to any

compression, which would measurably interfere with combustion, this consequently permits of as high a temperature being at that point, *i. e.*, thus low in the combustion chamber, as well as above it.

Q, Q, are air valves set in the induction air pipes which connect with the chamber or chambers C at the bridge wall, where by the supply of oxygen may be regulated, absolutely, according to the nature of the flame required to accomplish the special results desired.

The operation of the furnace has been already indicated in the foregoing, and it is only necessary to suggest that in starting the furnace, the cover, K, is first removed, then the air valves, Q, Q, are opened, then a rag saturated with oil, or other means of ignition, is dropped in through the open door K, then the gas is turned on which is immediately ignited, thereupon the cover is replaced and the furnace runs itself the gas and air supplies being properly regulated, until the necessary temperature is attained preparatory to charging the furnace, thereupon the cover, K, is again removed and the charge, whatever it may be, is introduced.

It will be noticed that my furnace is adapted to the performance of various kinds of work, necessitating, however, certain changes in the form or composition of the independent bottom, that is to say, for a smelting or glass furnace a concave bottom, as shown, may be employed, the bottom, of course, being supplied with the usual duct or ducts (as shown in Fig. 1), for drawing off the products; (not shown). For a heating furnace, a flat upper surface, or one only slightly concave may be given to the independent bottom; and for crucible heating, tile or terra cotta and the like work a perfectly flat or table form may be used, also the composition of the surface of the hearth may be changed when it is to have a reactive effect on the charge. Also my hearth can be vertically adjusted relative to the combustion chamber for the purpose stated.

I call special attention to certain peculiarities in the construction of my furnace, which I believe have never been employed before, that is to say, in other furnaces the bridge wall has been located between the space or chamber in which the ignition of the gases takes place and the combustion or work-doing chamber, and it has had the effect not only of reducing the available work doing energy of the flame, a portion of it being dissipated in the combustion chamber before entering the work doing chamber, but also the bridge walls as ordinarily constructed are obstructions or deflectors, over which the flame had to pass to get to the chamber in which the work was done, therefore, there was not only a reduction of available heat but also a checking or compressing effect produced upon the flame, between the space or chamber in which combustion first takes place, and the chamber in which the work is done; moreover the de-

flection stated tended to throw the flame in the first instance against the roof or arch of the furnace which consequently is exposed to the most intense heat and its maximum energy is consequently not only lost, but brings about in a comparatively short time the destruction of the arch, whereas in my furnace, all the energy is expended in the work doing chamber and in direct contact with the charge and instead of there being any obstruction or wall or contracting or compressing effect, there is an immediate expansion or enlargement of the space, so that there is no hindrance whatsoever to the instant and complete combustion of the fuel; and my bridge wall furthermore under my preferred construction entirely surrounds the sides of the combustion chamber, which I also believe to be a new feature, so that all the heat is retained and the working part of the furnace is protected from radiation, and such radiation as does take place is utilized in the heating of the incoming air. To these peculiar features together with those above stated I attribute the results which I secure, which are much more satisfactory than those secured by any other furnace known to me; that is to say, I can and habitually do, attain and maintain any given temperature practically uniform throughout the combustion chamber, using about twenty-five per cent. less fuel than in any other construction of furnace known to me; also my furnace is perfectly noiseless, because I have no obstructing bridge wall, which in other furnaces occasions a rapid succession of percussive ignitions of the rapidly expanding air and gases within the combustion chamber or work-doing part of the furnace. Also my furnace by very slight and inexpensive alterations or modifications can be adapted to a great variety of work.

I do not limit myself to the details of construction shown and described, since they may be somewhat departed from and still the essential features of my invention be employed.

I claim—

1. The combination in a regenerative furnace of a bridge wall entirely surrounding the sides of the combustion chamber, a chamber outside of the bridge wall connecting with the external air and opening at the lower end of the combustion chamber, inlets for gas, also opening at or below the lower end of the combustion chamber, and a hearth adapted to carry the charge, substantially as set forth.

2. The combination in a regenerative furnace of a bridge wall entirely surrounding the sides of the combustion chamber, a chamber which surrounds the bridge wall, and which connects with the external air and opens at the lower end of the combustion chamber, inlets for gas, opening at or below the end of the combustion chamber, and a hearth adapted to carry the charge, substantially as set forth.

3. The combination in a regenerative furnace of a bridge wall entirely surrounding the sides of the combustion chamber, a chamber

around the bridge wall, connecting with the external air and opening at the lower end of the combustion chamber, an independent chamber outside of the air chamber connecting with the upper end of the combustion chamber, through which the products of combustion pass on their way to the stack inlets for gas opening at or below the lower end of the combustion chamber, and a hearth adapted to carry the charge, substantially as set forth.

4. The combination in a regenerative furnace of a bridge wall entirely surrounding the sides of the combustion chamber, a chamber on each side of the bridge wall across which projections extend from the side walls to the opposite wall, whereby the structure is braced and supported without interfering with the independent expansion of the two sides of the said chamber, said chamber or chambers connecting with the external air and opening at or below the lower end of the combustion chamber, and inlets for the gas, opening at or below the lower end of the combustion chamber, substantially as set forth.

5. The combination in a regenerative furnace of a combustion chamber, contracted at its lower end, a bridge wall which entirely surrounds the sides of the combustion chamber,

a chamber or space outside of the bridge wall connecting with the external air and opening at the contracted lower end of the combustion chamber and inlets for the gas also opening at the lower contracted end of the combustion chamber, substantially as set forth.

6. The combination in a regenerative furnace, of a combustion chamber contracted at its lower part, a bridge wall which entirely surrounds the sides of the combustion chamber, a chamber or space outside of the bridge wall connecting with the external air and opening at the contracted lower end of the combustion chamber, inlets for the gas also opening at the lower contracted end of the combustion chamber and a chamber outside of the said air chamber connecting with the upper end of the combustion chamber adapted to convey the products of combustion from it to the stack, substantially as set forth.

Signed at New York, in the county of New York and State of New York, this 16th day of November, A. D. 1892.

MARTIN WANNER.

Witnesses:

PHILLIPS ABBOTT,
M. L. FERRES.