

(12) INTERNATIONAL APPLICATION PUBLISHED UNDER THE PATENT COOPERATION TREATY (PCT)

(19) World Intellectual Property Organization
International Bureau



(43) International Publication Date
26 April 2012 (26.04.2012)

(10) International Publication Number
WO 2012/053877 A1

- (51) **International Patent Classification:**
G01N 21/31 (2006.01) *G01N 21/84* (2006.01)
- (21) **International Application Number:**
PCT/LT2011/000012
- (22) **International Filing Date:**
3 October 2011 (03.10.2011)
- (25) **Filing Language:** English
- (26) **Publication Language:** English
- (30) **Priority Data:**
2010 091 20 October 2010 (20.10.2010) LT
- (71) **Applicant (for all designated States except US):** UAB "ŽEMDIRBIŲ KONSULTACIJOS" [LT/LT]; Vaigeliškių k., Sudervės pšt., LT-14204 Vilniaus r. (LT).
- (72) **Inventors; and**
- (75) **Inventors/Applicants (for US only):** PETKUS, Vytautas [LT/LT]; Apuolės g. 34-1, LT-48300 Kaunas (LT). PE-TRAUSKAS, Ernestas [LT/LT]; Šlaito g. 41, Gaiženėlių k., Kačerginės pšt., LT-53454 Kauno r. (LT).
- (74) **Agent:** PETNIŪNAITĖ, Jurga; J. Jasinskio g. 16A, PO Box 33, LT-01002 Vilnius (LT).
- (81) **Designated States (unless otherwise indicated, for every kind of national protection available):** AE, AG, AL, AM, AO, AT, AU, AZ, BA, BB, BG, BH, BR, BW, BY, BZ, CA, CH, CL, CN, CO, CR, CU, CZ, DE, DK, DM, DO,

DZ, EC, EE, EG, ES, FI, GB, GD, GE, GH, GM, GT, HN, HR, HU, ID, IL, IN, IS, JP, KE, KG, KM, KN, KP, KR, KZ, LA, LC, LK, LR, LS, LT, LU, LY, MA, MD, ME, MG, MK, MN, MW, MX, MY, MZ, NA, NG, NI, NO, NZ, OM, PE, PG, PH, PL, PT, QA, RO, RS, RU, RW, SC, SD, SE, SG, SK, SL, SM, ST, SV, SY, TH, TJ, TM, TN, TR, TT, TZ, UA, UG, US, UZ, VC, VN, ZA, ZM, ZW.

- (84) **Designated States (unless otherwise indicated, for every kind of regional protection available):** ARIPO (BW, GH, GM, KE, LR, LS, MW, MZ, NA, RW, SD, SL, SZ, TZ, UG, ZM, ZW), Eurasian (AM, AZ, BY, KG, KZ, MD, RU, TJ, TM), European (AL, AT, BE, BG, CH, CY, CZ, DE, DK, EE, ES, FI, FR, GB, GR, HR, HU, IE, IS, IT, LT, LU, LV, MC, MK, MT, NL, NO, PL, PT, RO, RS, SE, SI, SK, SM, TR), OAPI (BF, BJ, CF, CG, CI, CM, GA, GN, GQ, GW, ML, MR, NE, SN, TD, TG).

Declarations under Rule 4.17:

— of inventorship (Rule 4.17(iv))

Published:

- with international search report (Art. 21(3))
- before the expiration of the time limit for amending the claims and to be republished in the event of receipt of amendments (Rule 48.2(h))

(54) **Title:** METHOD AND DEVICE FOR DIAGNOSING PLANT GROWING CONDITIONS

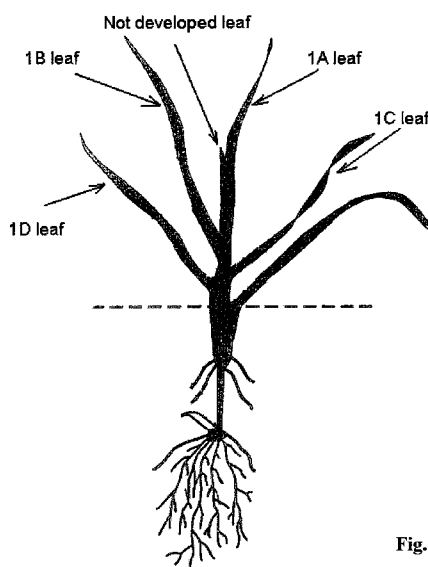

Fig. 1

(57) **Abstract:** The invention relates to the method and the device for diagnosing plant growing conditions. The invention is aimed to detect the deficiency of the main chemical elements (Fe, B, Mn, Zn, Cu, Mo) during the vegetation period of the plant. The method and device for the diagnosing of plant growing conditions is based on the irradiation of the leaves of different age (1A, 1B, 1C, 1D,...) placed in separate chambers by visible and infrared light, and the spectrum analysis of the light reflected from the leaves. The estimation of the deficiency of micro elements and the diagnosis of the plant is performed according to the measured differences between the spectra of a light reflected from all the leaves of the plant.



WO 2012/053877 A1

Method and device for diagnosing plant growing conditions

Field of the invention

The invention relates to the methods and the devices for diagnostics of the growth conditions of a plant.

In principle for most of the plants 17 chemical elements are sufficient to grow and develop full vegetation. Some plants require additional 3 or 6 chemical elements, but for summer wheat 17 are enough: C, H, O, N, P, K, Ca, Mg, S, Mn, Fe, B, Cu, Zn, Mo, Ni, Cl (macro- and micro- elements). Mn, Fe, Mo, Ni are heavy metals, therefore, in the case of over fertilization, high concentration of these metals in the plants and the soil is harmful. Each element performs different functions in the processes of growing and vegetation. Each element is irreplaceable; therefore the deficiency of one of the elements cannot be compensated by another element.

The light in the plants is absorbed by pigments. During the photosynthesis the ability of the pigments' molecules to transfer the energy, when excited by light, to other molecules has significant importance, because the energy, which is absorbed from the waves of a light is transformed into chemical energy and is used for the assimilation of carbon dioxide. When the molecules of these points are excited the energy of the light quantum is transformed into chemical energy and is used for the assimilation of carbon dioxide.

There are a few hundreds of pigments of different colours in the plants. According to the chemical content and structure, pigments are divided into four groups: chlorophylls, carotenoids, phycobilins and flavonoids. The chlorophylls, carotenoids, and phycobilins are used for photosynthesis.

Background art

Most spectrophotometric methods for evaluation of growth conditions of plants are based on their fluorescent emission. The fluorescent emission occurs after the irradiation of a plant with visible white light of the wavelength ranging from 400 to 650 nm. During the fluorescent emission in the dark the plant emits infrared light with the wavelength components of 690 nm and 740 nm. The emission of components of said wavelength of light shows the ability of a plant to synthesise chlorophyll as well as reflects the amount of water (biomass

index) and nitrogen in it. Moreover, mainly nitrogen is needed for the synthesis of chlorophyll in the plants.

The following inventions are based on said effect:

DE10148737 relates to the method of estimation of biophysical parameters in the leaves of a plant. The method is based on the irradiation of leaves by using a xenon flash lamp and subsequent spectral analysis of the reflected visible and infrared light. The reflected light is transmitted through the optic filters which are adjusted for different wavelengths of the light. Different wavelengths of the split light are detected with separate light detectors.

US2005072935 relates to the portative device for diagnostics of plants' growth. The device is based on the irradiation of a plant with light having the wavelength spectrum from 400 nm to 650 nm by using an array of the light emitting diodes (LED) and the spectral analysis of fluorescent emission of the plant. The efficiency of the photosynthesis is determined according to the levels of the received light components of wavelength of 690 nm and 740 nm.

WO 99/35485 describes that the dominant wavelength of components of light of fluorescent emission are of 700 nm and 840 nm. WO 99/35485 also describes the system of optic lenses with optic filters used for filtering of components of the emitted light and an electronic device used for the detection and evaluation of the intensity of these components of light. The device estimates the amount of the chlorophyll in the plant according to the measured levels of components of light.

The amount of chlorophyll in the plant can be also estimated by analysing the spectrum of the light that is reflected from or has passed through the leaves.

The patent DE10002880 relates to the system for diagnostics of the growth parameters of plants based on the irradiation of their leaves with the passive (daylight) or active (LED or laser light of different wavelengths) light, the analysis of the spectrum of the reflected light and emitted fluorescent light and subsequent data transmission (by internet). The diagnostics and data transmission is performed in a GPS equipped vehicle which is passing through the fields and performs the diagnoses of growth of the plants growing in different places on the fields. The leaf surface index, the amount of chlorophyll and water in the plants are determined by analysing the spectrum of the reflected light and emitted fluorescent light.

JP2006250827 relates to a device for determining the growth conditions of rice crops. The operation of the device is based on the spectral analysis of the digital images of the plants

in the fields, taken from an airplane or a satellite. By analysing the components B16 and B17 of the spectra of the said images it is possible to evaluate the amount of proteins in the plants (rise). The methods of multi-regression are applied for the analysis of the photo images.

US6567537 relates to the plants' diagnostics system based on the analysis of the images of the plants taken with digital cameras. The analysis of the digital images at the wavelength of 550 nm represents the amount of light reflected by chlorophyll, at the wavelength of 680 nm - the amount of light absorbed by chlorophyll and the analysis at the wavelength of 770 nm represents the index of biomass of a plant (biomass index represents amount of water contained in a plant).

WO2009007269 relates to the portable device designed for the evaluation of water amount in the plants. The operation of the device is based on irradiation of plants by light from two LEDs. One LED has the wavelength of the light which is attenuated by the amount of water in the plant. The second LED has the wavelength of the light which is not attenuated by the amount of water in the plant. The amount of water in the plants is determined according to the levels of the detected components of spectrum of light after the light passes through the leaves. Only two LEDs with the fixed wavelengths are used.

All the methods and devices mentioned above are capable of reflecting the capabilities of plants to synthesize chlorophyll or showing the amount of water (biomass) in the plant, but none of these methods allows to determine the lack of particular chemical elements in plants.

The invention described in the patent US6683970 is the nearest prototype to our invention. The patent US6683970 relates to the method and the device for diagnostics of the crops. The device is based on the spectrum analysis of the digital images of daylight reflected from the crops. The spectrum of the reflected light is analysed from the images of the whole field of plants taken at various angles. The optical filters for filtering the light of the fixed wavelengths (450, 550, 625, 650, 675, 700 nm for visible light and 750, 850, 950-1300 nm for infrared light) are interchanged by rotating them around for separation of different components of spectrum of the reflected light. The amount of nitrogen in crops is determined according to the spectra of the reflected light at different places of the fields. The patent US6683970 also relates to the portable device for determining the quantity of nitrogen in the leaves of plants according to the spectral analysis of the light reflected from the leaves. The LEDs are used as the light sources of different wavelengths. Used together with the optical filters for visible and infrared light they form light spectrum of the wavelengths from 550 nm to 1100 nm. However,

the patent US6683970 relates to the method which allows us to determine only one chemical element (nitrogen) needed for the plant.

Background of the invention

Each chemical element influences the intensity of pigments' activity in the plant in different ways. The aim of the invention is related to the estimation of the deficiency of main chemical elements (Fe, B, Mn, Zn, Cu, Mo) in the plant during the period of vegetation.

Each of said chemical elements is associated with different mobility. The plant compensates the deficiency of each chemical component in different manner. Some elements are transferred from older leaves to younger ones according to the plant's needs; other elements are transferred partially or they are left in the old leaves. Young leaves grow and develops during the process of vegetation. Such young leafs are characterized by lighter colour. The processes of photosynthesis have higher intensity in older and already developed leaves than in youngest leaf. During the photosynthesis energy produced in the leaves is transferred to a plant. Such leaves are of a darker colour. The difference between younger and older leaves is associated with different processes occurring in these leaves, therefore the amount of micro- and macro- elements are assimilated differently. Also, the processes of photosynthesis are of different intensity. The spectrum of light from young and old leaves will also be different.

The growing conditions of the plant can be evaluated according to the colours of their leaves. After irradiating leaves with visible or infrared light the light will be reflected and the spectrum of the reflected light can be used to characterise the colour of the leaves and to evaluate the growth conditions of a plant.

The spectrum of light reflected from a healthy plant (growth period was abundant of all necessary micro- and macro- elements) and the plant with the deficiency of micro- and macro- elements during the growth period will be different.

A different spectrum will be obtained for the light reflected by different leaves of the same plant (for example, the plant of wheat has 6 leaves). The youngest leaf of healthy summer wheat is of light green colour, because the intensity of photosynthesis in this leaf is low. An older leaf, where the intensity of photosynthesis is higher, is of a darker green colour. The spectrum of the reflected light from these leaves will be different. The activity and density of the pigments in the leaves will be different with each leaf, if they were provided with different amount of micro- and macro- elements during their development. Herewith, the

differences in the spectra of the reflected light of the leaves that grew with the deficiency of any mentioned elements will be smaller than the differences in the spectra of the reflected light of a healthy plant.

According to the spectra of the reflected light from younger and older leaves and the difference between these spectra it is possible to diagnose the conditions of growth of a plant and to determine the chemical elements needed for the vegetation of a plant. Timely diagnoses of deprivation of specific micro- and macro- elements can help to provide the necessary elements to improve the growth conditions of plants (i.e. to fertilize the plants with necessary elements).

This invention relates to the method of diagnostics of the growth conditions of a plant, comprising means of irradiation of the leaves of a plant with visible or infrared light and the analysis of the light reflected from different leaves. The new features in the invention are as follows:

- for the analysis of the intensity of the light reflected from the leaves, at least two leaves of different age are used. The difference between the intensities as a function of the wavelength is analysed;
- the differences between the two leaves of different age are compared between a healthy plant (a reference plant which grew in optimal conditions) and the tested plant;
- the diagnosis of the deficiency of chemical elements is performed according to the differences of the measured spectra.

During the measurements, the leaf is placed in a dark chamber and is irradiated with an LED light sources. The light from an LED is guided to a leaf by using optical fibers. The reference plant and the plant under the testing can be wheat, rye, barley, rape and other agricultural plants.

The device intended for use in method of diagnostics of the growth conditions of a plant contains a chamber for placement of a leaf, LED for irradiation of a leaf, photodetectors for the detection of light, an amplifier, an analog-to-digital converter and a microcontroller for data processing and storage. The proposed device is characterized by having at least two dark chambers for placement of leaves; at least two LEDs with an electronic control circuits for each chamber; at least two photodetectors for the detection of the light reflected from the leaves, and one microcontroller which is capable of performing the measurements of the

spectra differences of the reflected light from the leaves placed in at least two different chambers.

The light guide is used for guiding the LED light to the leaves. For the expansion of the range of the light spectrum, light from an additional infrared LED and an RGBA (red-green-blue-amber) LED are mixed using an additional lens. According to this invention the most desirable configuration of said device contains four dark chambers for placement of leaves, four LEDs with the electronic control circuits, four photodetectors for detection of the light reflected from the leaves. The device according to this invention is calibrated by using reference sheets of paper of black and white colour.

Brief description of the drawings

Fig. 1 is a numbering of leaves of summer wheat;

Fig. 2 is a block diagram of the diagnostic device in accordance with the invention (first embodiment);

Fig. 3 is block diagram of the diagnostic device in accordance with the invention (second embodiment);

Fig. 4 is a block diagram of the diagnostic device in accordance with the invention (third embodiment);

Fig. 5 is a plot of the differences between the spectra of the light reflected from the youngest 1A and older 1B leaves of summer wheat which grew under optimal conditions;

Fig. 6A is a plot of the differences between the spectra of the light reflected from the leaves of summer wheat which grew under optimal conditions and with the deficiency of iron (Fe). The dotted line is a spectrum difference of youngest leaves 1A. The solid line is the spectrum difference of older leaves 1B;

Fig. 6B is a plot of the differences between the spectra of the light reflected from the youngest 1A and older 1B leaves of summer wheat which grew with the deficiency of iron (Fe) (dotted line) and under optimal conditions (solid line) ;

Fig. 7A is a plot of the differences between the spectra of the light reflected from the leaves of summer wheat which grew under optimal conditions and with the deficiency of boron (B). The dotted line is a spectrum difference of youngest leaves 1A. The solid line is the spectrum difference of older leaves 1B;

Fig. 7B is a plot of the differences between the spectra of the light reflected from the youngest 1A and older 1B leaves of summer wheat which grew with the deficiency of boron (B) (dotted line) and under optimal conditions (solid line) ;

Fig. 8A is a plot of the differences between the spectra of the light reflected from the leaves of summer wheat which grew under optimal conditions and with the deficiency of manganese (Mn). The dotted line is a spectrum difference of youngest leaves 1A. The solid line is the spectrum difference of older leaves 1B;

Fig. 8B is a plot of the differences between the spectra of the light reflected from the youngest 1A and older 1B leaves of summer wheat which grew with the deficiency of manganese (Mn) (dotted line) and under optimal conditions (solid line) ;

Fig. 9A is a plot of the differences between the spectra of the light reflected from the leaves of summer wheat which grew under optimal conditions and with the deficiency of zinc (Zn). The dotted line is a spectrum difference of youngest leaves 1A. The solid line is the spectrum difference of older leaves 1B;

Fig. 9B is a plot of the differences between the spectra of the light reflected from the youngest 1A and older 1B leaves of summer wheat which grew with the deficiency of zinc (Zn) (dotted line) and under optimal conditions (solid line) ;

Fig. 10A is a plot of the differences between the spectra of the light reflected from the leaves of summer wheat which grew under optimal conditions and with the deficiency copper (Cu). The dotted line is a spectrum difference of youngest leaves 1A. The solid line is the spectrum difference of older leaves 1B;

Fig. 10B is a plot of the differences between the spectra of the light reflected from the youngest 1A and older 1B leaves of summer wheat which grew with the deficiency of copper (Cu) (dotted line) and under optimal conditions (solid line) ;

Fig. 11A is a plot of the differences between the spectra of the light reflected from the leaves of summer wheat which grew under optimal conditions and with the deficiency molybdenum (Mo). The dotted line is a spectrum difference of youngest leaves 1A. The solid line is the spectrum difference of older leaves 1B;

Fig. 11B is a plot of the differences between the spectra of the light reflected from the youngest 1A and older 1B leaves of summer wheat which grew with the deficiency of molybdenum (Mo) (dotted line) and under optimal conditions (solid line) ;

Summary of the invention

The block diagram of the diagnostic device in accordance with the invention is presented in Fig 2.

The operation of the device is based on the following procedures:

The youngest and older leaves 1A and 1B are irradiated by light from an RGB or RGBA LED diodes 4 (composed of three (Red-green-blue) or four (Red-green-blue-amber) colours of an LED sources). The wavelength of the irradiated light is changed from 400 nm to 1100 nm by driving the LEDs via electronic circuit 6 (current amplifiers). The range of RGBA LED wavelength can be 460 – 700 nm. Additional LEDs of fixed infrared and ultraviolet wavelength are used for light spectrum expansion from nm up to 1100 nm.

The lights from RGBA and infrared LEDs are guided through the flexible light guides 3 (for example - fiber optics) to the dark chambers 2 where the leaves 1A and 1B are positioned (two separate chambers for each leaf). The diameter of light guide 3 is from 1 mm to 5 mm. The outer surface of the light guide is covered with a dark light absorbing material (or light reflecting material from inside) for better light propagation within the light guide.

The light reflected from each leaf goes through the receiving light guide 3 and is received by photodetectors 7.

The light signal is converted into an electrical signal by photodetectors 7 and then sent to the differential amplifier 8. The output signal from the differential amplifier 8 is converted into a digital signal in an analog-to-digital converter 9 for further processing in the microcontroller 10. The microcontroller 10 controls the process of measurement and performs the measurements of the differential spectrum.

The difference of the measured spectra of the reflected light is expressed by the formula:

$$U(\lambda_i) = k(\lambda_i) [I_1(\lambda_i) - I_2(\lambda_i)] + \Delta U(\lambda_i),$$

here I_1 and I_2 are intensities of the reflected light;

k is the transfer coefficient (gain) of the amplifier, the light guide and the LED sources (dependant on the wavelength)

λ_i is the wavelength of the light;

$\Delta U(\lambda_i)$ is an additive error of measurements caused by zero drift of the amplifier and by differences between the measurement channels of first and second leaves.

The measurements are performed by changing the colour of an LED from $\lambda = 400$ nm to $\lambda = 1100$ nm in discrete steps. The difference $I_1(\lambda_i) - I_2(\lambda_i)$ is measured at each fixed value of the wavelength of the light.

k is the transfer coefficient (gain) of the amplifier, the light guide and LED sources (depends on the wavelength). The function $k(\lambda_i)$ is obtained by calibrating the measurement system with a white sheet of paper. The additive error $\Delta U(\lambda_i)$ due to zero drift of the amplifier and differences between the measurement channels is obtained by calibrating the system with a black sheet of paper.

The microcontroller 10 performs the measurement of the spectrum difference $\Delta I(\lambda) = I_1(\lambda) - I_2(\lambda)$ and transfers the results of the diagnosis of the plant to the display 12 or the computer 11.

The simplified embodiment of the device for plants' diagnosis is presented in Fig 3. The RGBA and an infrared LED source 4 with a lens 5 for mixing the light are used in the device. Light from the light source is guided to both dark chambers 2 in the flexible light guides 3. The advantage of such an embodiment of the device is less components (light sources).

The embodiments of the device presented in Fig. 2 and Fig. 3 allow us to perform simultaneous measurements of the spectra difference of the light reflected from youngest and older leaves. For the complete diagnosis of the growth phases of a plant the device can be equipped with up to 4 measuring channels. It would expand the capability of the device to perform measurements of spectra differences of various leaves:

- between the youngest leaf 1A and older leaf 1B,
- between the youngest leaf 1A and older leaf 1C,
- between the youngest leaf 1A and older leaf 1D,
- between the older leaf 1B and older leaf 1C,
- between the older leaf 1B and older leaf 1D,
- between the older leaf 1C and older leaf 1D,

In the case of summer wheat, here: 1A is a youngest leaf, 1B is an older leaf, emerged 7 days earlier than 1A; 1C is an older leaf, emerged 14 days earlier than 1A; 1D is the oldest leaf, emerged 21 days earlier than 1A (in the case of summer wheat, a new leaf emerges every 7 days).

The measurement of the spectra differences of the light of different leaves would allow us to determine in which leaves the effective processes of photosynthesis takes place (fully developed leaves) and in which leaves photosynthesis is not fully functioning (due to the deficiency of micro- and macro- elements or not finished vegetation in younger leaves).

The embodiment of the plant diagnostic device which is capable of performing the measurements of spectra differences between different leaves is presented in Fig. 4. The light from an RGBA and an infrared LED source 4 is mixed in the device by using the lens 5. The light from the source is guided to four dark chambers 2 in the flexible light guides 3. In each chamber the four leaves (a leaf per chamber) 1A, 1B, 1C and 1D of the same plant are irradiated. The signals of reflected light from different leaves are fed to differential amplifiers 8 and subsequently to analog-to-digital converters 9. The microcontroller 10 performs the measurement of spectra difference and outputs the results of the plant diagnosis to the display 12 or the computer 11.

The advantage of such embodiment of the device is the capability to get full information about the efficiency of the processes of photosynthesis and vegetation for each leaf.

Experimental results

The experimental studies showed that the intensities of the reflected light spectra $I_1(\lambda)$, $I_2(\lambda)$ and the difference $I_1(\lambda) - I_2(\lambda)$ of a healthy plant, as a function of wavelength of reflected light, are typical for one type of the plant (for summer wheat). The spectra $I_1(\lambda)$, $I_2(\lambda)$ of the light reflected from a healthy plant (which grew with the provision of all needed micro- and macro- elements) and the plant with the deficiency of micro- and macro- elements (Mn, Fe, Cu, Zn, Mo, B) were different. Also, the difference of the spectra of the light reflected from the youngest 1A leaf and the older 1B leaf were different for the healthy plant and for the plant which grew with the deficiency of micro- and macro- elements.

The results of experimental studies are shown in Figs. 5-11.

The results show that for a healthy the spectra differences of the light reflected from the youngest 1A leaf and the older 1B leaf is highest within the whole range of the light spectrum. In the cases when the deficiency of the chemical element was artificially induced during the experimentation, the difference of the spectra of the light reflected from the youngest 1A leaf

and the older 1B leaf were smaller. Moreover, said difference had distinctive characteristics depending on the deficiency of a particular chemical element.

Figs. 5A, 6A, 7A, 8A, 9A, 10A and 11A show the spectra differences of the light reflected from the 1A and 1B leaves of summer wheat which grew with the deficiency of particular micro- and macro- elements and the summer wheat which grew in optimal conditions. These plots illustrate that differential spectra provide diagnostic information and are characterized by futures of individual functions for each case of the deficiency of micro- and macro- elements. These measurements can be done by means of the device presented in Fig. 4.

The experimental studies presented in Figs. 5-11 were performed by using the spectrophotometer Lambda 35. The samples of summer wheat used for this study grew in a laboratory conditions in the receptacles. The samples of summer wheat grew in different conditions:

- optimal conditions with the provision of all micro- and macro- elements;
- growing with the deficiency of iron, but with a full provision of all other micro- and macro- elements;
- growing with the deficiency of boron, but with a full provision of all other micro and macro elements;
- growing with the deficiency of manganese, but with a full provision of all other micro and macro elements;
- growing with the deficiency of zinc, but with a full provision of all other micro and macro elements;
- growing with the deficiency of copper, but with a full provision of all other micro and macro elements;
- growing with the deficiency of molybdenum, but with a full provision of all other micro and macro elements.

Industrial application

The new method and the device for diagnostics of plants according to the invention is based on the measuring the differences between the spectra of the light reflected from the leaves of a plant. Such a method was not mentioned in other patents. The spectra of the light

reflected from leaves depend on the pigments which are influenced by the chemical elements accumulated in a plant during the period of its growth.

In the case of the deficiency of particular chemical element, the amount of that element will be different in an earlier developed and just developing leaves. The plant compensates the deficiency of each chemical component in a different manner: by transferring some missing elements from older leaves to younger ones. However, some elements are transferred partially or they are left in the old leaves. Therefore, the chemical contents in younger and older leaves, as well as the spectra of the reflected light from these leaves are different.

The method and the device according to the invention is capable of performing the measurements of the spectra differences of the light reflected from different leaves:

- between the older and younger leaves of the same plant (by comparing the differences between 4 leaves simultaneously). It would allow us to evaluate which leaves are still under vegetation, and which leaves produce chlorophyll, and how effectively the chlorophyll is synthesized.
- to compare the leaves of the plant under testing with the healthy plant. The comparison is available between the youngest leaves (1A) which are under development of pigments and the older leaves (1B, 1C, 1D) which already started to synthesize chlorophylls.
- the results of the measurement of the spectrum of the light of a healthy plant can be recorded into the memory of the device (or transferred to a computer) and used as a reference spectrum data for further measurements.

The technical advantage of the new method is the possibility to minimize the instrumental errors (due to the differences of some futures of the measurement channels and their drift, and the non-uniformity of the amplitudes of the spectra of the light of the light guides) by implementing the measurement of the spectrum difference. For full minimisation of these instrumental errors, the calibration of the zero drift and difference of some futures of the measurement channels is performed by using black and white sheets of paper.

According to the invention other essential properties related to the design of the device are as follows:

- One RGBA LED together with an additional infrared LED and ultraviolet LED are used for expanding the range of measurement of the light spectrum up to 1100 nm. By driving LEDs with the electronic circuits it is possible to form the

light spectrum from 400 nm up to 1100 nm. It simplifies the design of the device, because only few (up to 3) diodes are used.

Compared to other inventions, it is not necessary to use an LED array comprising a high number of LEDs (usually >3) with a different wavelengths of light, and to mechanically change the optical filters (no moving parts). The lens 5 is used for additional mixing of light from RGBA, infrared and ultraviolet LEDs.

- The light, emitted from the light sources (to the leaves) and the light reflected from the leaves (to the photodetectors) are guided by means of the flexible optical guides (for example - fiber optics). Such implementation minimises direct (parasitic) light propagation from the light sources to the photodetectors. The light guide receiving the light reflected from the leaf is positioned to avoid the incident light emitted from the irradiating light guide. The chamber for a leaf placement has the inner black walls which absorb the irradiated light. The chamber is optically isolated from any external light source. The application of the flexible light tubes allows guiding of the light from one light source to a few measurement chambers. It allows us to implement simultaneous measurement of the light reflected from at least two leaves and to calculate the spectra difference of the light.

CLAIMS

1. A method for the diagnostics of the growth conditions of a plant, comprising the means for irradiation of a leaf by visible or infrared light, the light spectrum analysis, changing the wavelength of the light, **characterized in that** at least two leaves of different age are taken for analysis of the spectra of the light reflected from said at least two leaves;
difference between the spectra of light as a function of the wavelength is calculated;
spectra differences of reflected light from the leaves of different age of a plant under testing are compared to the spectra differences of reflected light from the leaves of different age of a reference plant which grew in optimal conditions;
according to the measured spectra differences deficiency of the chemical elements that occurred during the vegetation period is determined.
2. The method for the diagnostics of the growth conditions of a plant according to claim 1, **characterised in that** the light emitted from a light emitting diode is guided to the leaf of a plant by using the light guides.
3. The device for the diagnostics of the growth conditions of a plant, comprising the chamber for placing the leaf for testing, the light emitting diode for irradiation of the leaf of a plant, the photodetector for light detection, the amplifier, the analog-to-digital converter and the microcontroller for data processing and storage, **characterized in that** said device comprises at least two dark chambers for the placement of the leaves of a plant; at least two light emitting diodes with electronic control circuits for each chamber; at least two photodetectors for detection of the light reflected from the leaves; the microcontroller having the capability to perform the measurements of the differences of the spectra of the light reflected from leaves which are placed in at least two separate chambers.

4. The device for the diagnostics of the growth conditions of a plant according to claim 3, **characterized in that** the light emitted from a light emitting diode is guided to the leaf of a plant by using the light guides.
5. The device for the diagnostics of the growth conditions of a plant according to claims 3 and 4, **characterized in that** the optical lens is used for mixing of the light emitted from the visible and the infrared light sources.
6. The device for the diagnostics of the growth conditions of a plant according to any of the claims 3-5, **characterised in that** the device comprises four dark chambers for the placement of the leaves for testing and four light emitting diodes with an electronic control circuits for each chamber and also four photodetectors for detection of the light reflected from the leaves.
7. The device for the diagnostics of the growth conditions of a plant according to any of the claims 3-6, **characterised in that** said device is calibrated by means of white and black sheets of reference papers

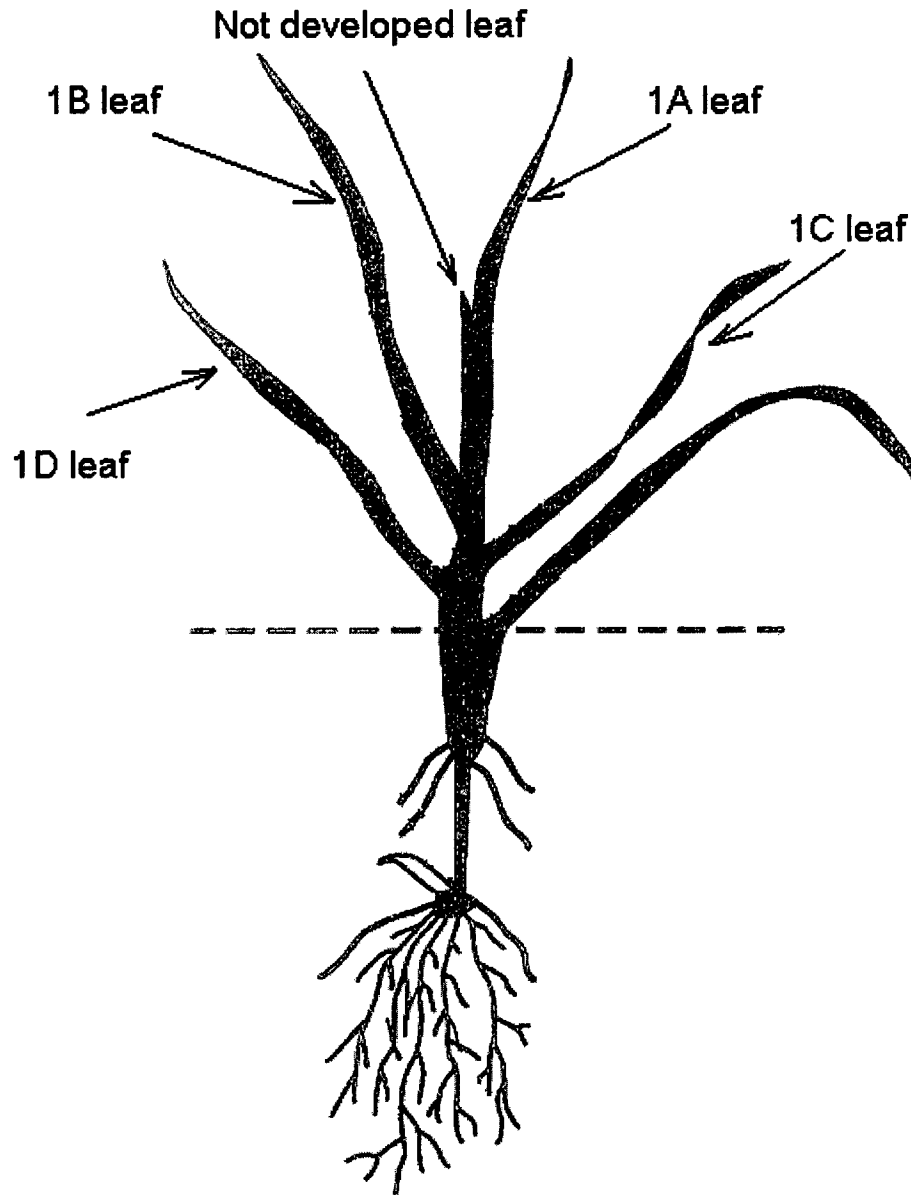

Fig. 1

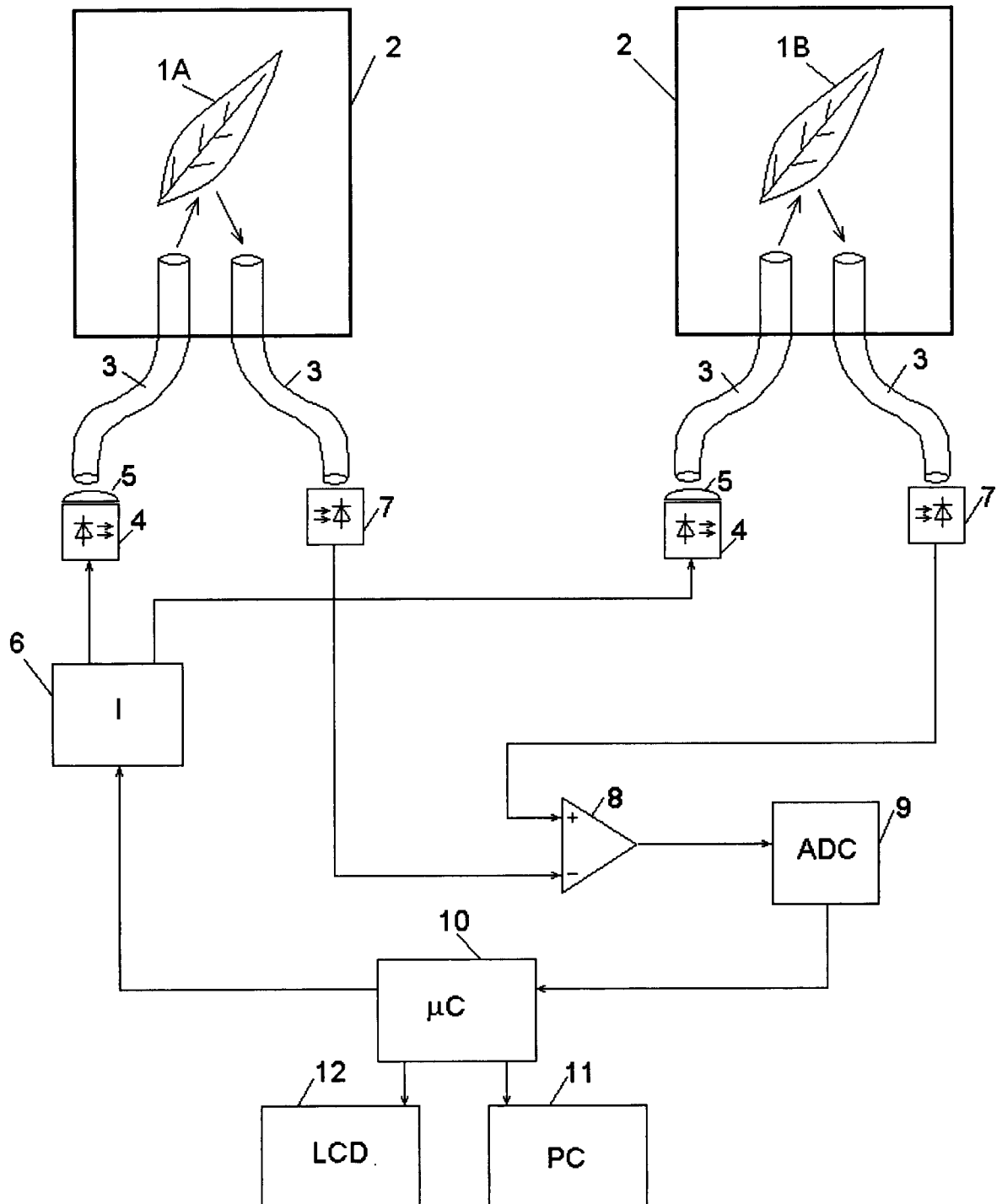

Fig. 2

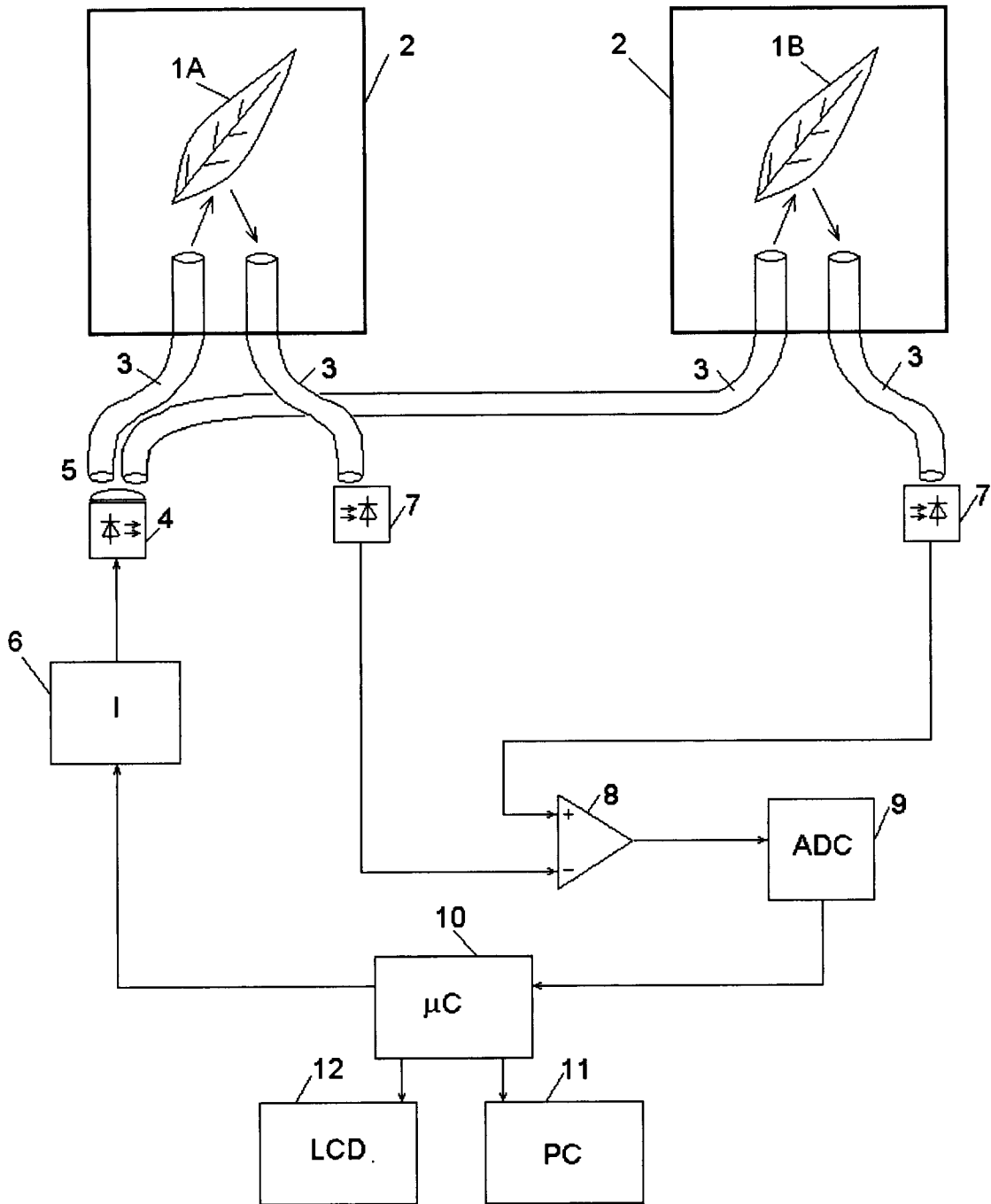

Fig. 3

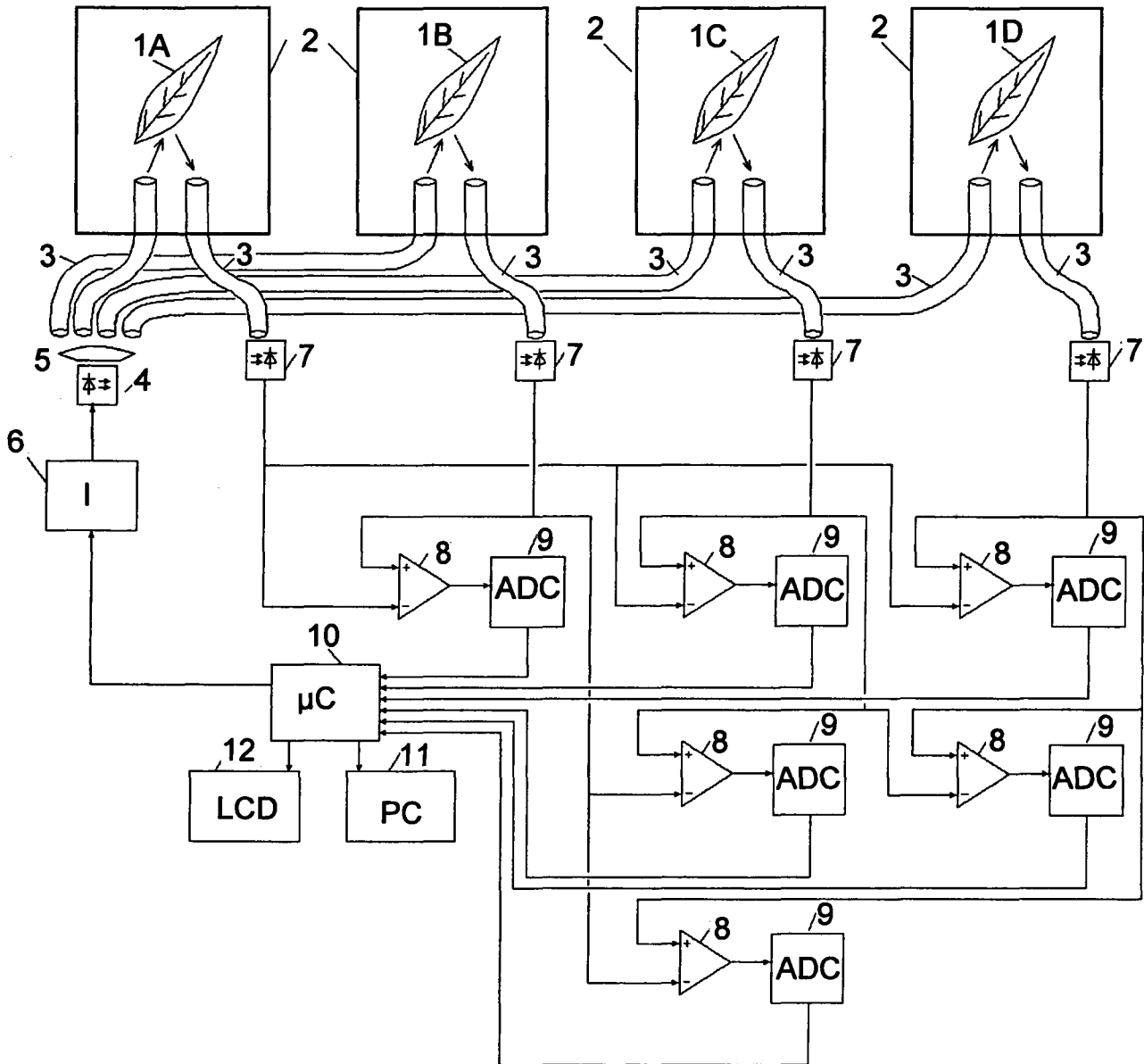

Fig. 4

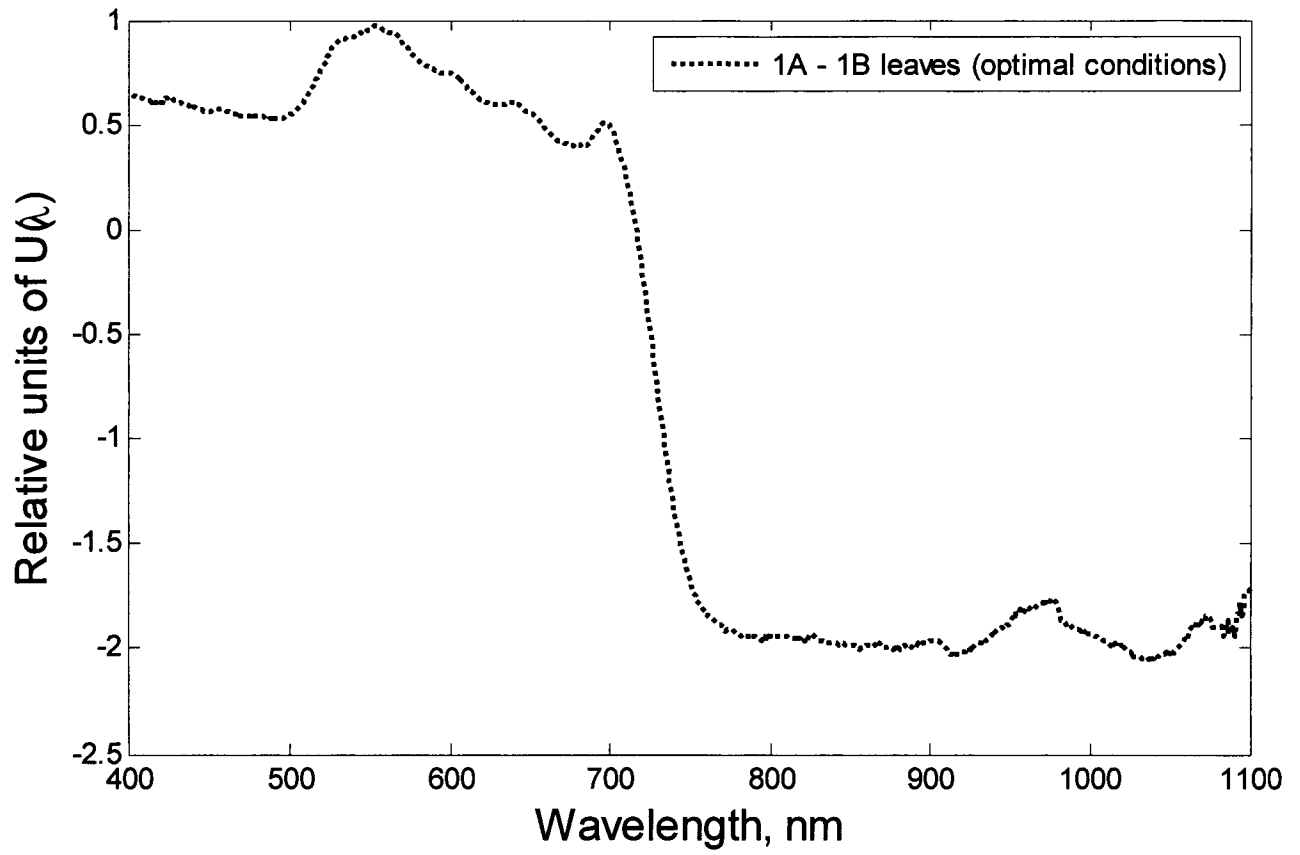

Fig. 5

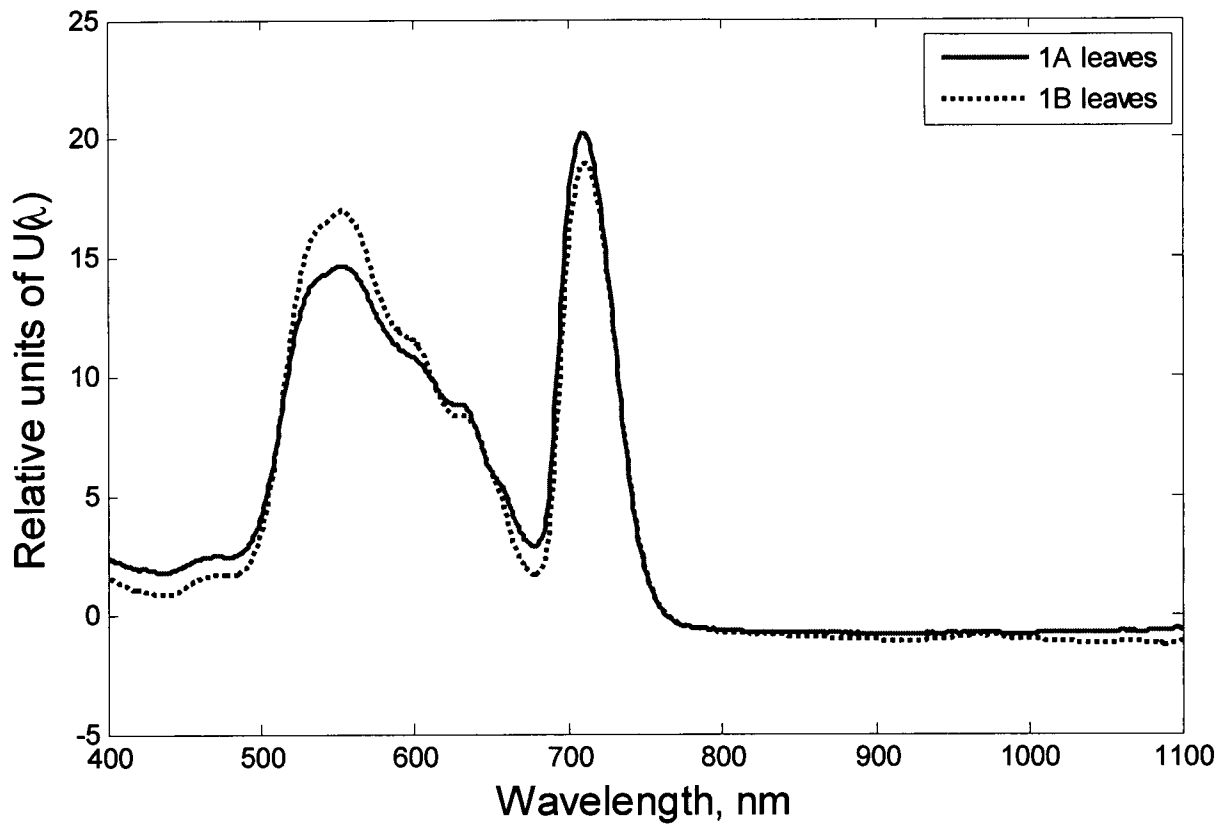

Fig. 6A

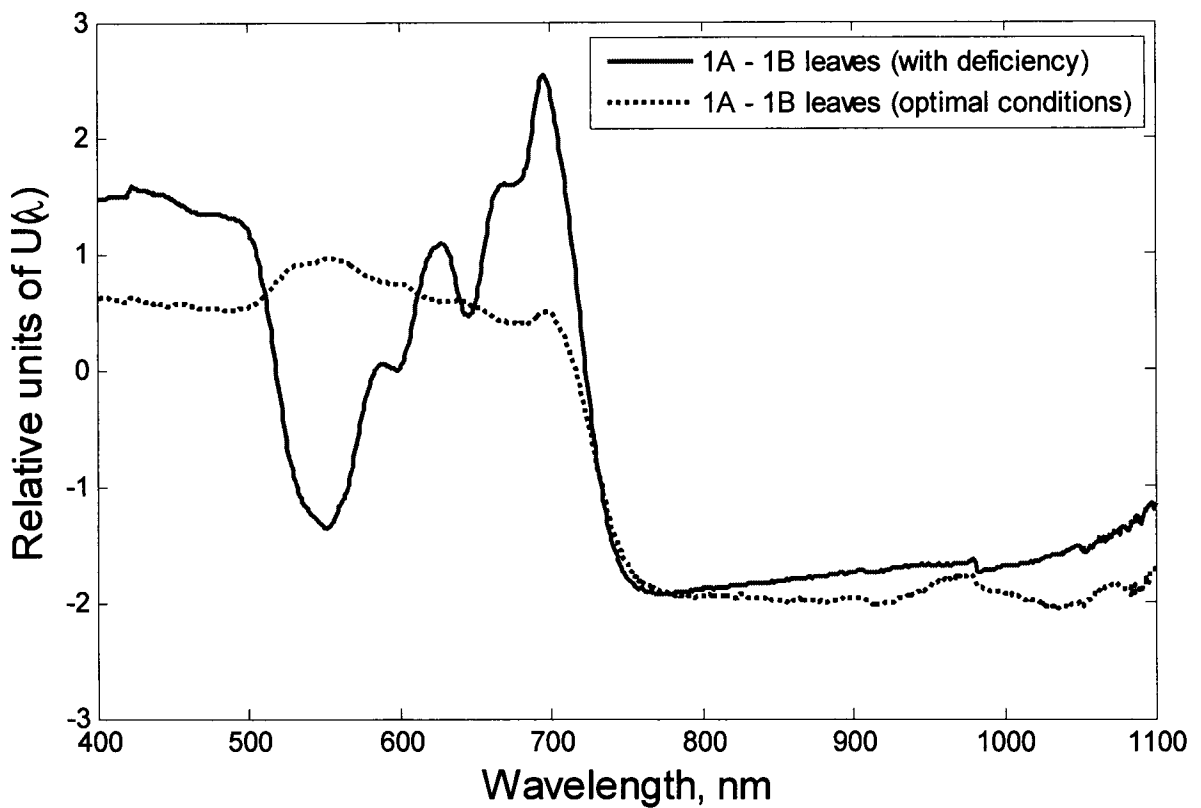

Fig. 6B

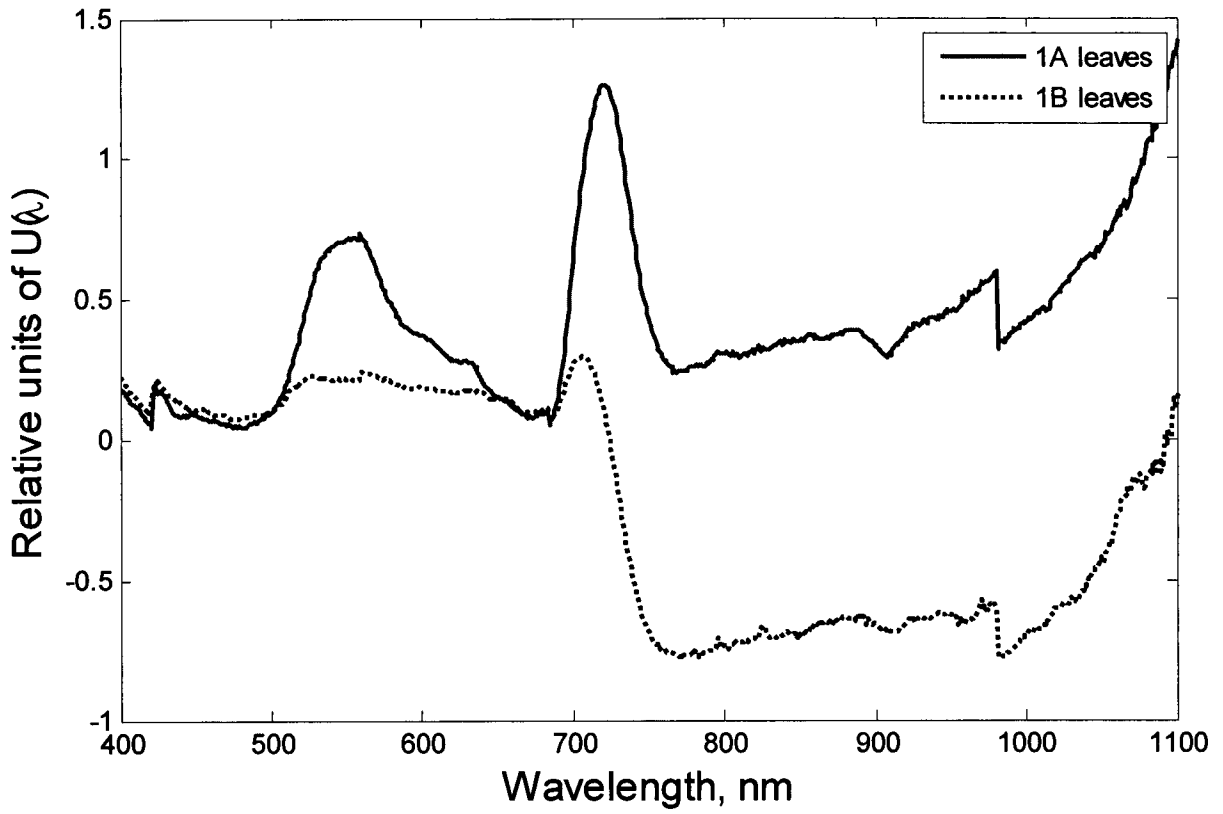

Fig. 7A

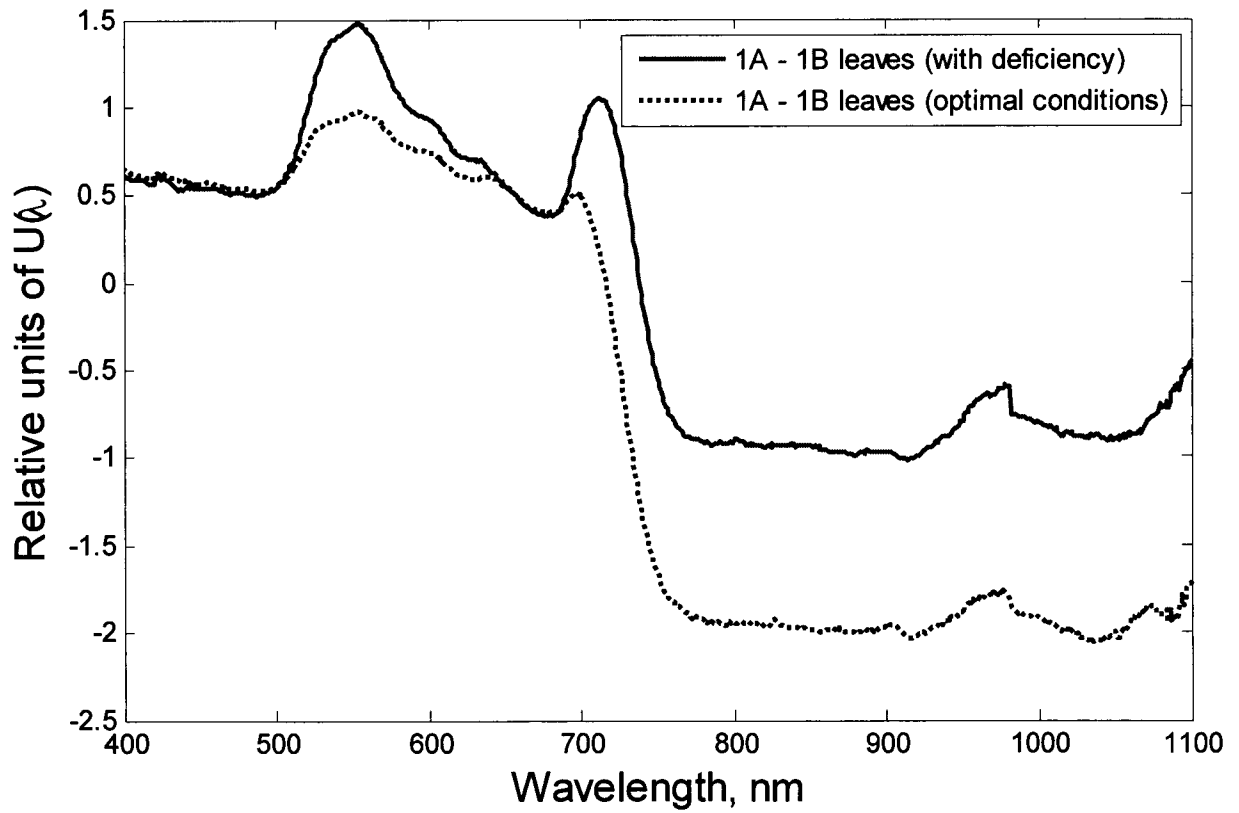

Fig. 7B

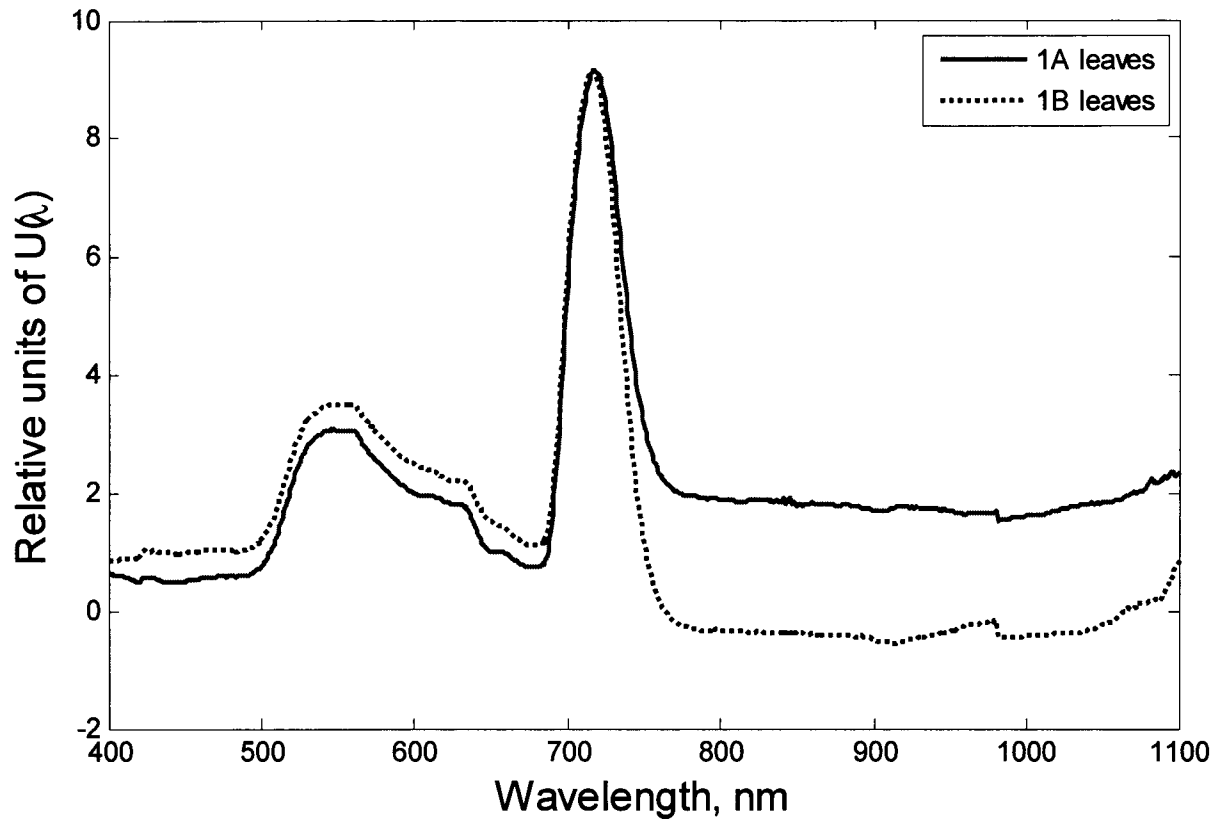

Fig. 8A

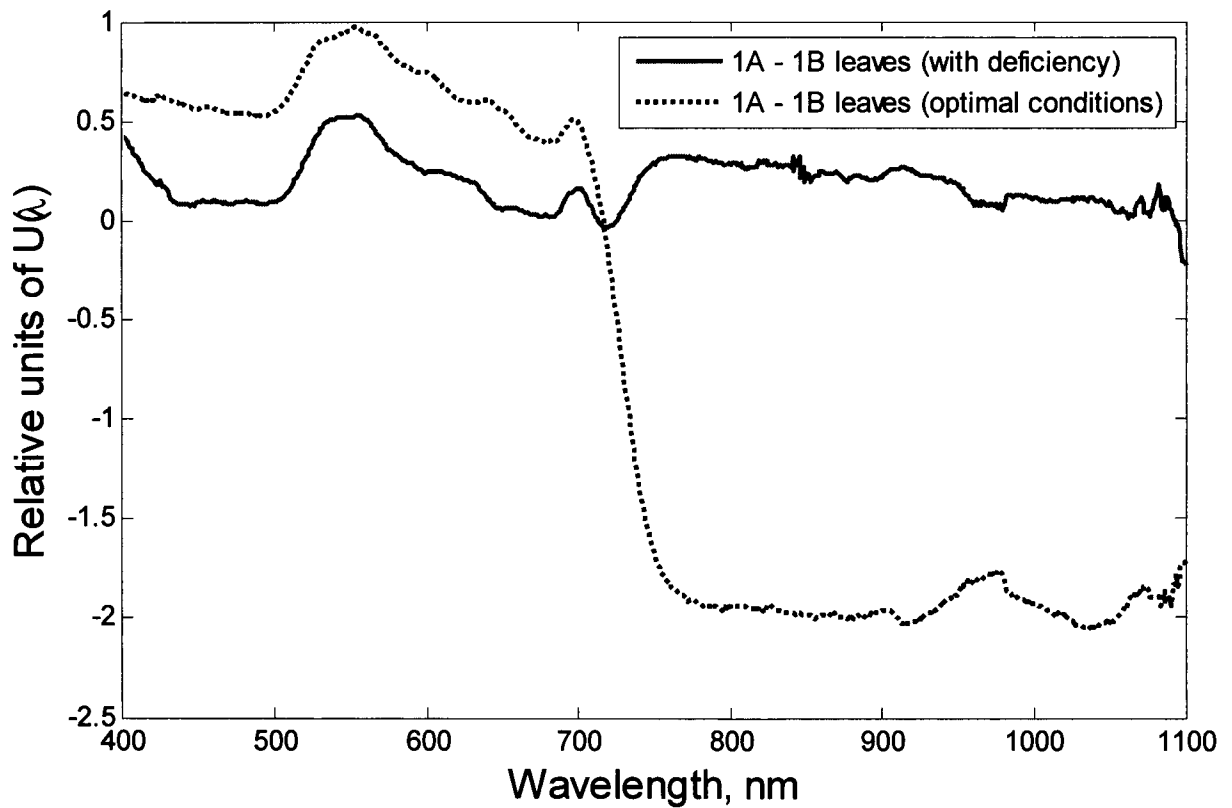

Fig. 8B

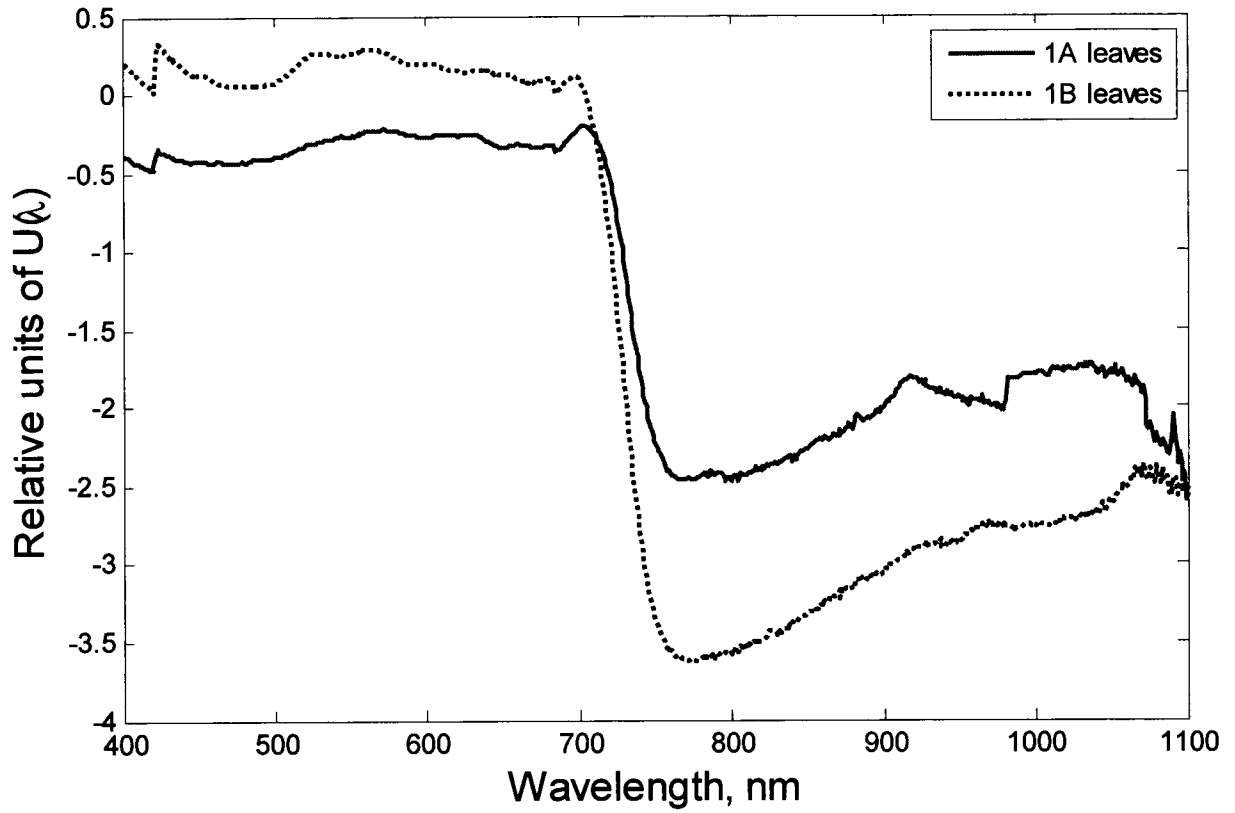

Fig. 9A

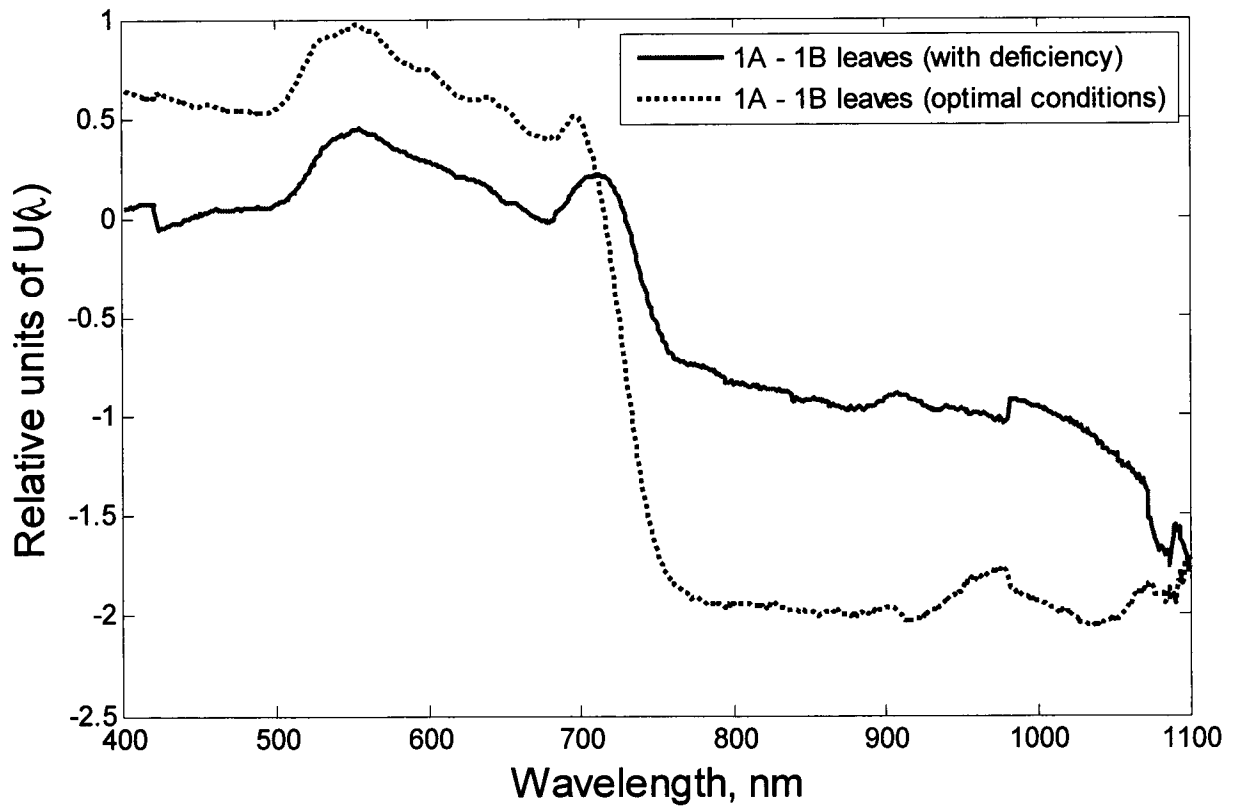

Fig. 9B

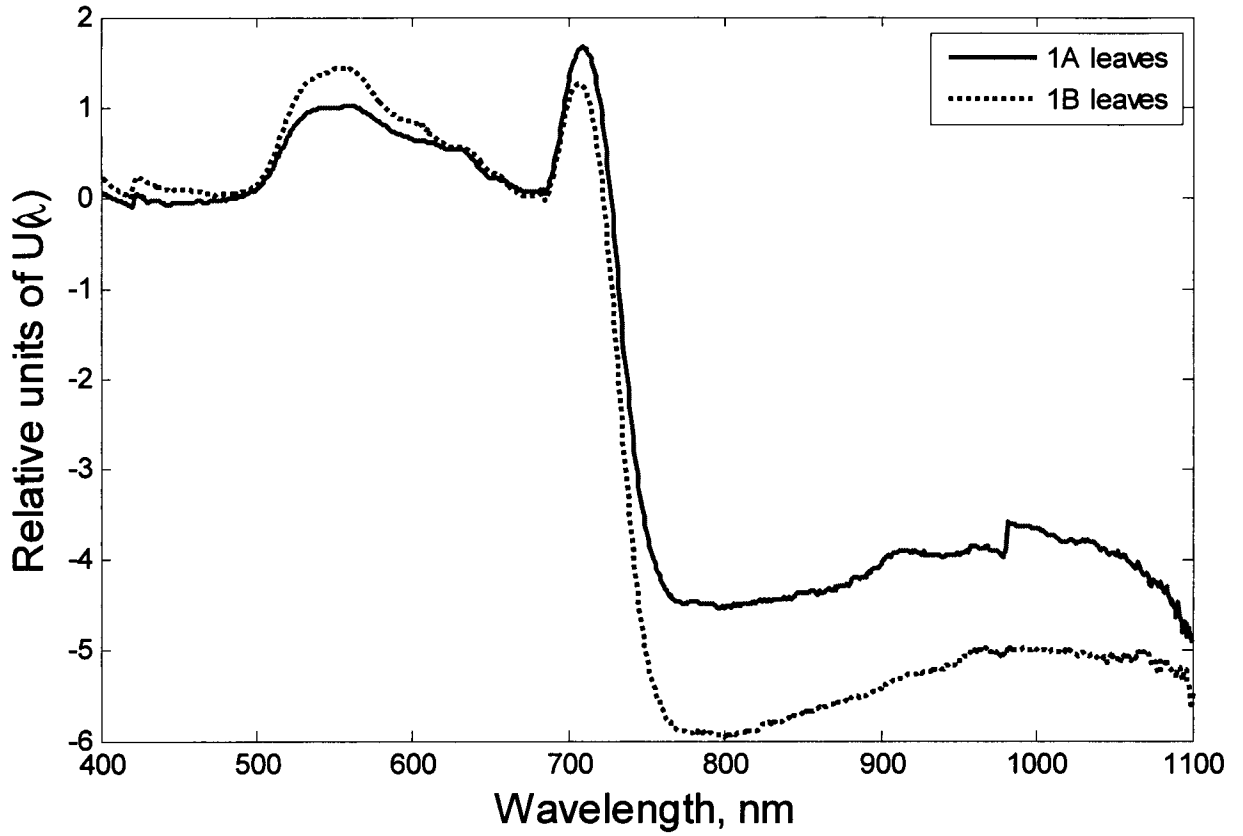

Fig. 10A

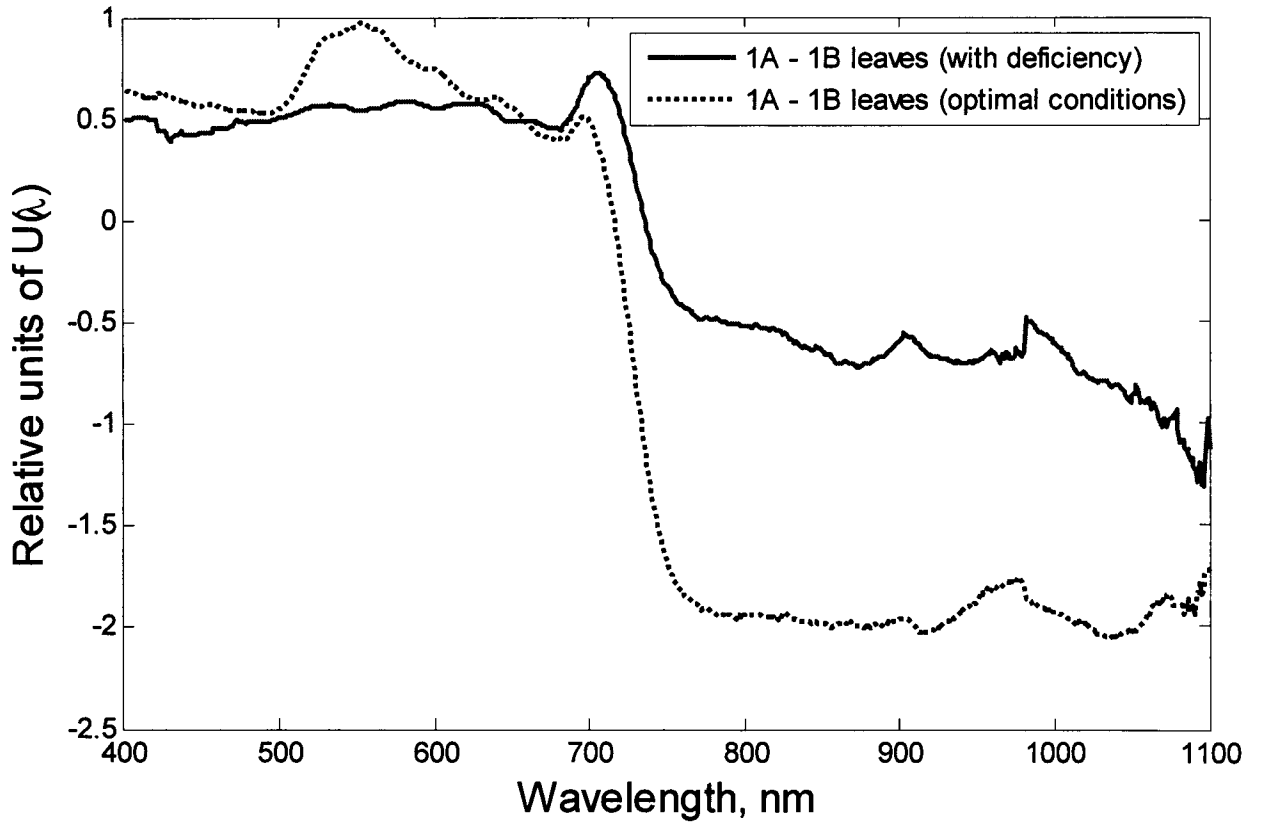

Fig. 10B

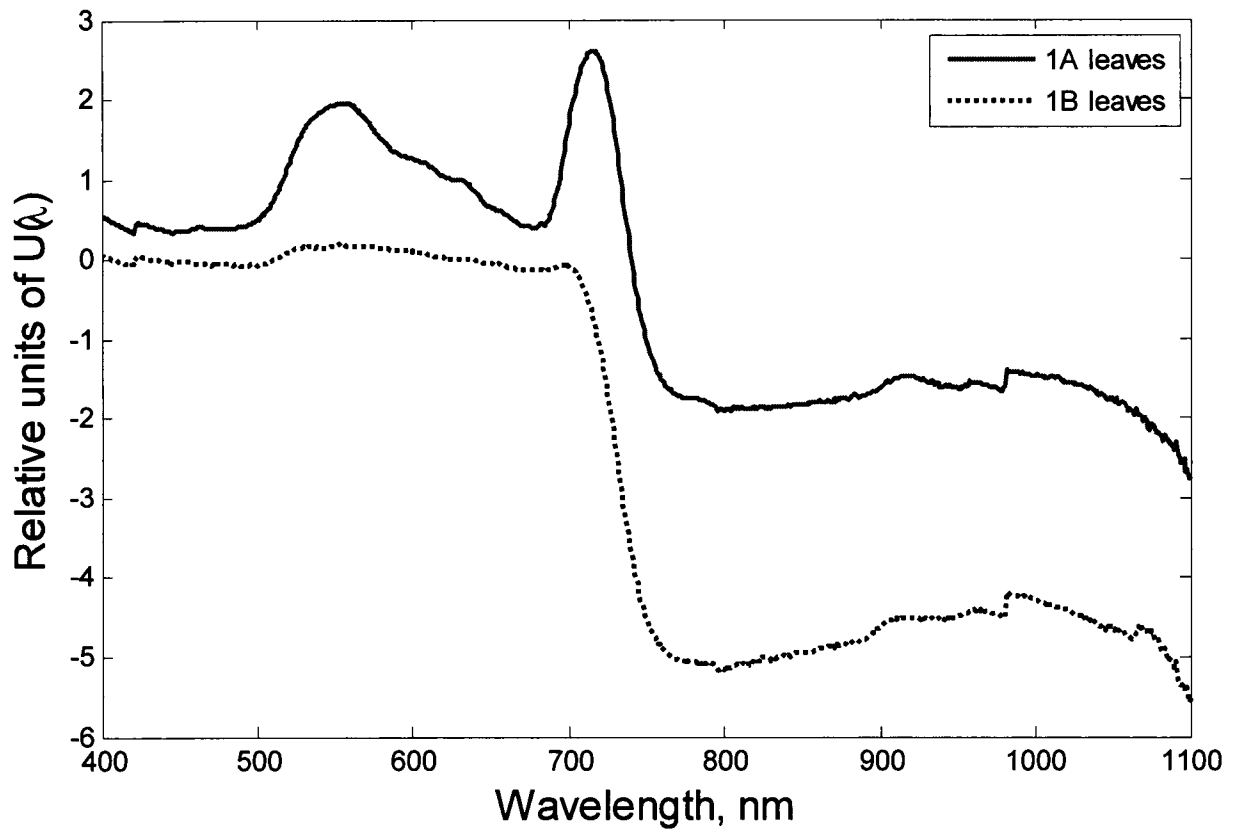

Fig. 11A

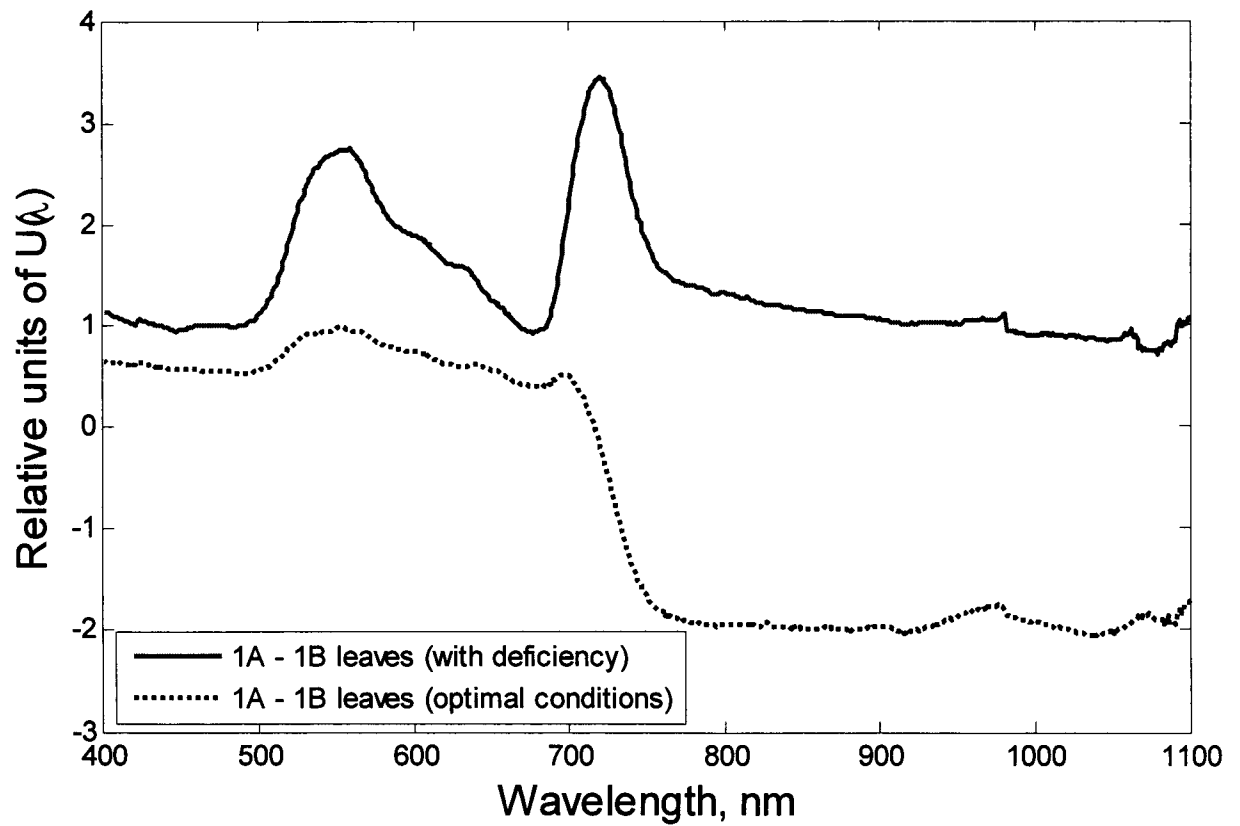

Fig. 11B

INTERNATIONAL SEARCH REPORT

International application No
PCT/LT2011/000012

A. CLASSIFICATION OF SUBJECT MATTER
INV. G01N21/31 G01N21/84
ADD.
According to International Patent Classification (IPC) or to both national classification and IPC

B. FIELDS SEARCHED
Minimum documentation searched (classification system followed by classification symbols)
G01N

Documentation searched other than minimum documentation to the extent that such documents are included in the fields searched

Electronic data base consulted during the international search (name of data base and, where practical, search terms used)
EPO-Internal

C. DOCUMENTS CONSIDERED TO BE RELEVANT

Category*	Citation of document, with indication, where appropriate, of the relevant passages	Relevant to claim No.
X	JP 2005 308733 A (NAGASAKI PREFECTURE) 4 November 2005 (2005-11-04) paragraphs [0015], [0034]; figures 12-14 -----	3-7
X	US 2005/098713 A1 (HOLLAND KYLE [US]) 12 May 2005 (2005-05-12) paragraphs [0064], [0065], [0068], [0074], [0075], [0076], [0079] -----	3-7
A	BINGQING LI: "Use of reflectance spectroscopy for early detection of calcium deficiency in plants", PROCEEDINGS OF SPIE, vol. 5852, 1 January 2005 (2005-01-01), pages 693-697, XP55022697, ISSN: 0277-786X, DOI: 10.1117/12.621886 paragraphs [0002], [0003] ----- -/--	1-7

Further documents are listed in the continuation of Box C.

See patent family annex.

* Special categories of cited documents :

"A" document defining the general state of the art which is not considered to be of particular relevance

"E" earlier document but published on or after the international filing date

"L" document which may throw doubts on priority claim(s) or which is cited to establish the publication date of another citation or other special reason (as specified)

"O" document referring to an oral disclosure, use, exhibition or other means

"P" document published prior to the international filing date but later than the priority date claimed

"T" later document published after the international filing date or priority date and not in conflict with the application but cited to understand the principle or theory underlying the invention

"X" document of particular relevance; the claimed invention cannot be considered novel or cannot be considered to involve an inventive step when the document is taken alone

"Y" document of particular relevance; the claimed invention cannot be considered to involve an inventive step when the document is combined with one or more other such documents, such combination being obvious to a person skilled in the art.

"&" document member of the same patent family

Date of the actual completion of the international search 23 March 2012	Date of mailing of the international search report 02/04/2012
--	--

Name and mailing address of the ISA/ European Patent Office, P.B. 5818 Patentlaan 2 NL - 2280 HV Rijswijk Tel. (+31-70) 340-2040, Fax: (+31-70) 340-3016	Authorized officer Navas Montero, E
--	--

INTERNATIONAL SEARCH REPORT

International application No
PCT/LT2011/000012

C(Continuation). DOCUMENTS CONSIDERED TO BE RELEVANT		
Category*	Citation of document, with indication, where appropriate, of the relevant passages	Relevant to claim No.
A	<p>OI WAH LIEW ET AL: "Signature Optical Cues: Emerging Technologies for Monitoring Plant Health", SENSORS, vol. 8, no. 5, 1 January 2008 (2008-01-01) , pages 3205-3239, XP55022698, ISSN: 1424-8220, DOI: 10.3390/s8053205 paragraph [02.3]</p> <p>-----</p>	1-7

INTERNATIONAL SEARCH REPORT

Information on patent family members

International application No

PCT/LT2011/000012

Patent document cited in search report	Publication date	Patent family member(s)	Publication date
JP 2005308733 A	04-11-2005	JP 4524473 B2	18-08-2010
		JP 2005308733 A	04-11-2005

US 2005098713 A1	12-05-2005	CA 2487115 A1	07-05-2005
		US 2005098713 A1	12-05-2005
		US 2006208171 A1	21-09-2006
