



US 20070125601A1

(19) **United States**

(12) **Patent Application Publication**  
**Lutze**

(10) **Pub. No.: US 2007/0125601 A1**

(43) **Pub. Date: Jun. 7, 2007**

(54) **LIGHT-WEIGHT SCAFFOLD BOARD AND METHOD FOR PRODUCING THE SAME**

(75) Inventor: **Gunter W. Lutze**, Frankfurt-Main (DE)

Correspondence Address:  
**GU DRUN E. HUCKETT DRAU DT**  
**LONSSTR. 59**  
**WUPPERTAL 42289 (DE)**

Apr. 13, 2002	(DE).....	102-16-569.6
Apr. 17, 2002	(DE).....	102-17-118.1
Mar. 13, 2002	(DE).....	102-21-250.3
Jun. 8, 2002	(DE).....	102-25-439.7
Jun. 16, 2002	(DE).....	102-26-703.0
Aug. 31, 2002	(DE).....	102-40-384.8
Jan. 11, 2003	(DE).....	103-00-886.1
Jan. 11, 2003	(DE).....	103-00-888.8

(73) Assignee: **UTI HOLDING + MANAGEMENT AG, FRANKFURT-MAIN GERMANY (DE)**

**Publication Classification**

(51) **Int. Cl.**  
**E04G 1/15** (2006.01)

(52) **U.S. Cl.** ..... **182/222**

(21) Appl. No.: **10/509,649**

(22) PCT Filed: **Mar. 30, 2003**

(86) PCT No.: **PCT/DE03/01048**

§ 371(c)(1),  
(2), (4) Date: **Apr. 17, 2006**

(57) **ABSTRACT**

(30) **Foreign Application Priority Data**

May 30, 2002	(DE).....	102-14-485.0
Apr. 9, 2002	(DE).....	102-15-606.9

A light scaffolding plate having various lengths and widths so as to fit with known scaffold systems is molded as a sandwich panel from a thermoplastic or duroplastic or a mixture of the two and is provided with a reinforcement. The upper and lower cover layers of the scaffolding plate is made of reinforced or unreinforced plastic material. Perforated sheet metal plates are embedded in the cover layers.

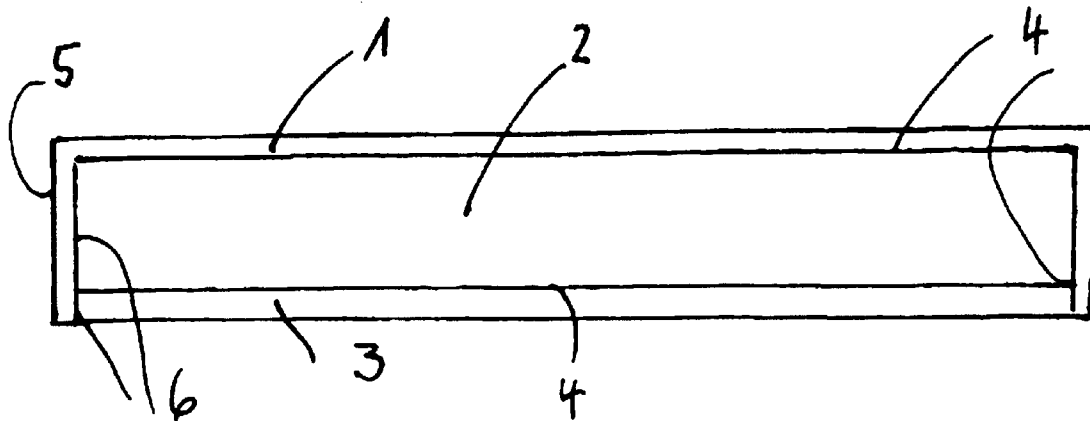

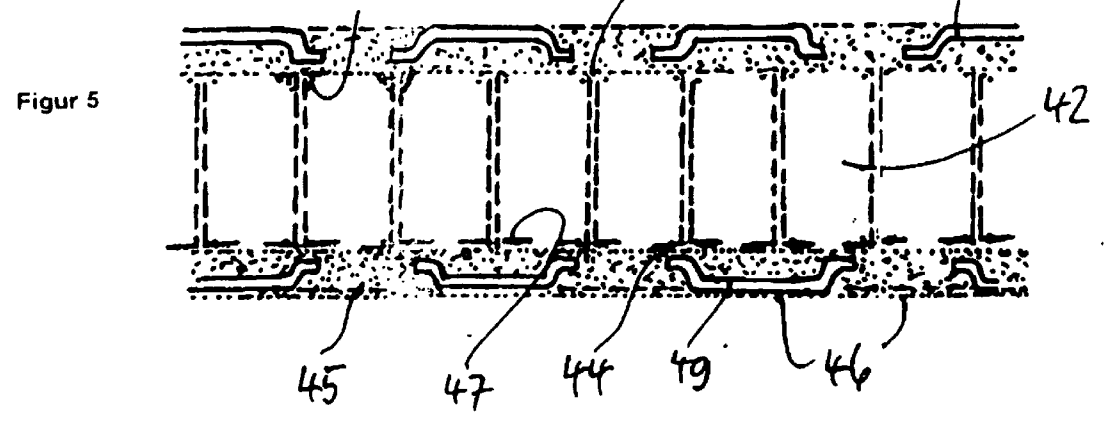
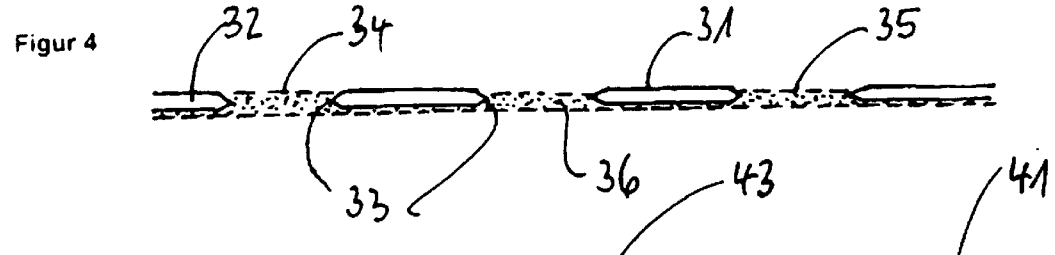
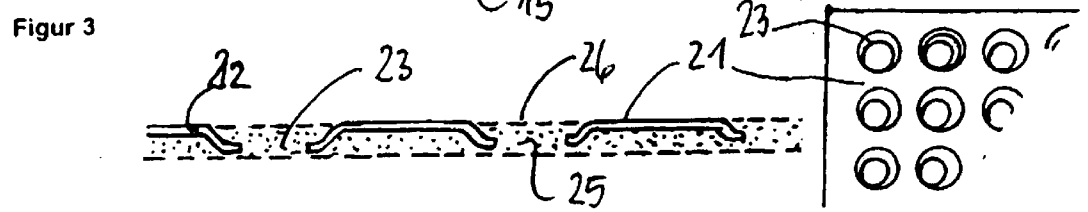
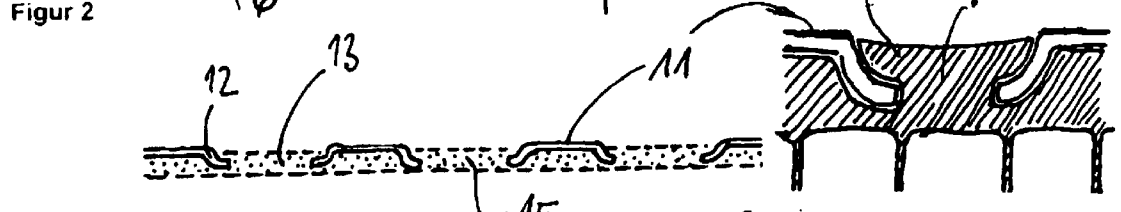
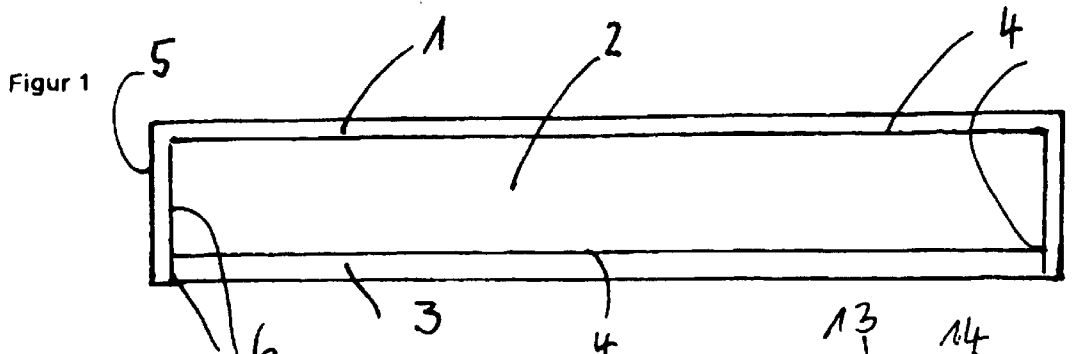

Figur 6

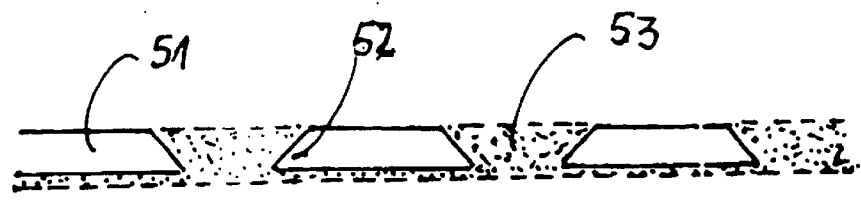

Figur 7

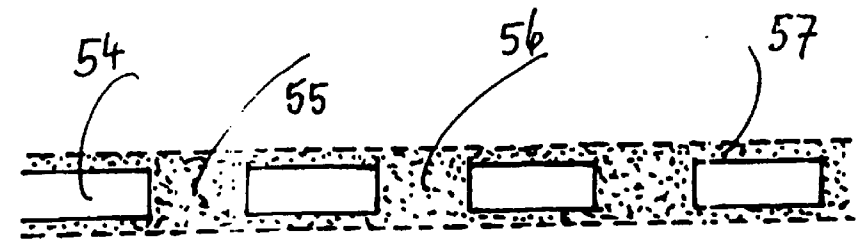

Figures 8 + 9

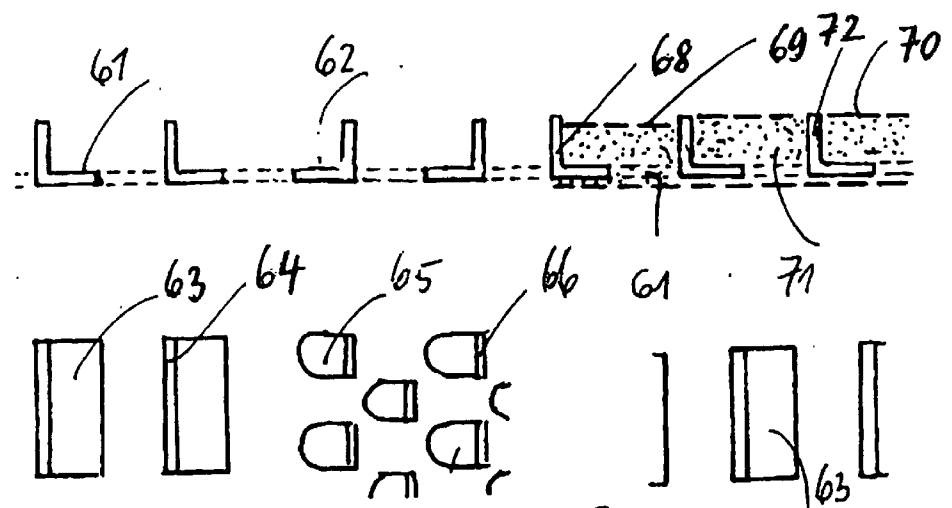

Figur 10

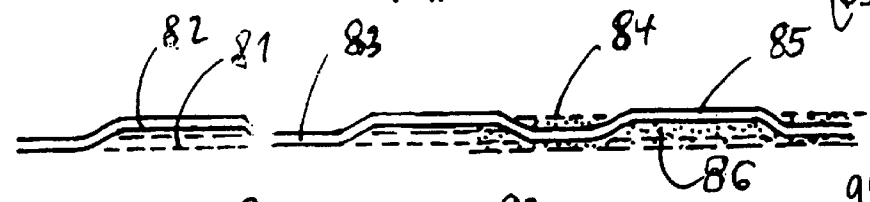

Figur 11

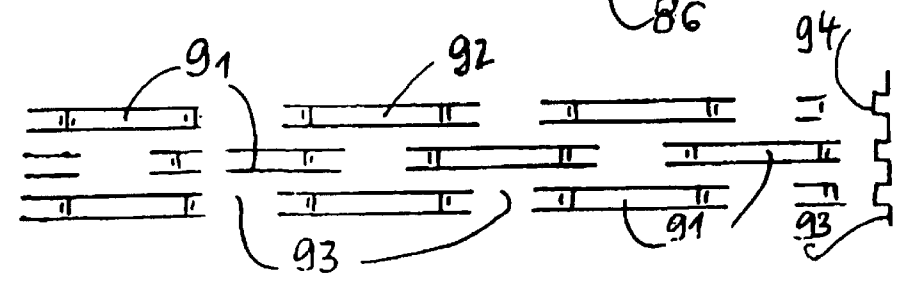

Figur 12

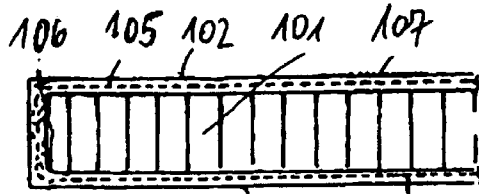

Figur 13 + 14

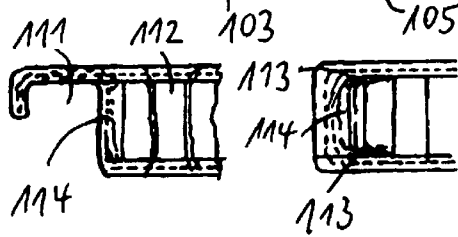

Figuren 15 + 16

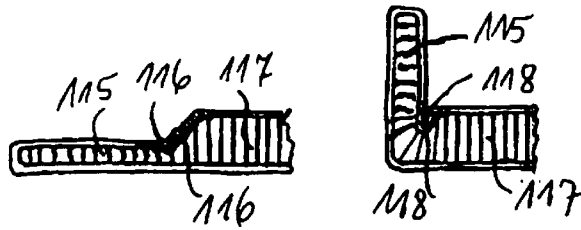

Figur 17 + 18

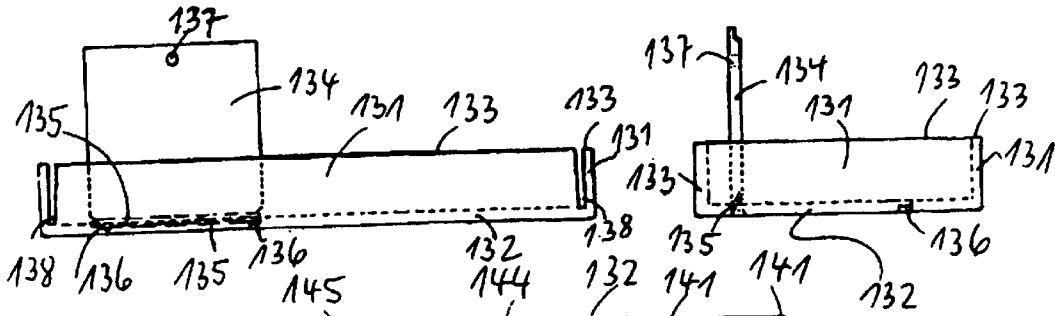

Figur 19

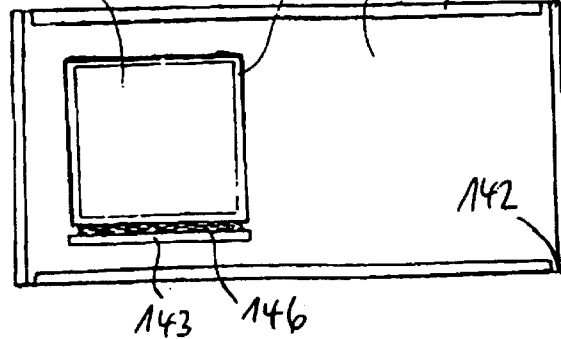

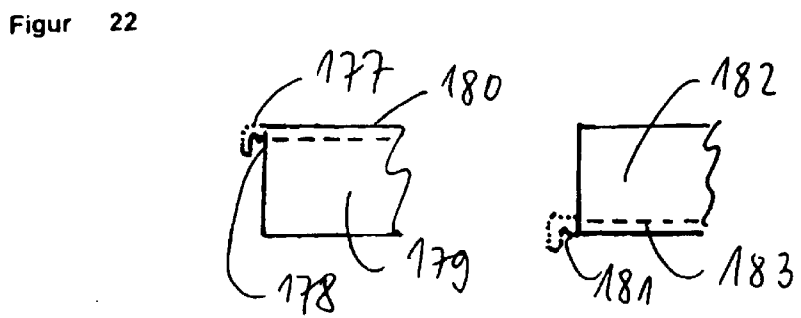
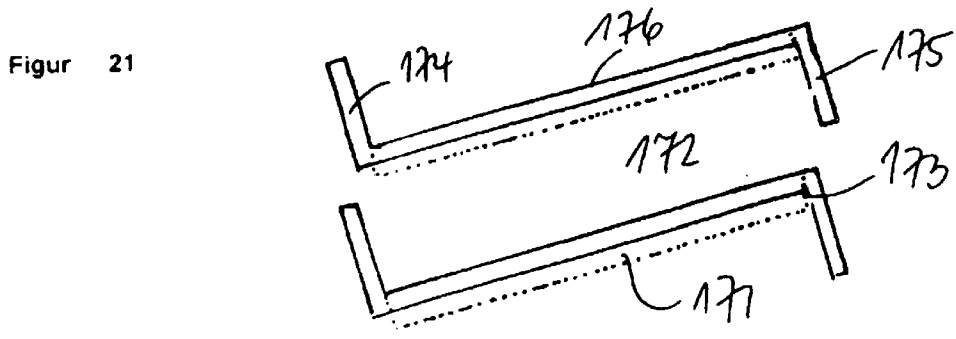
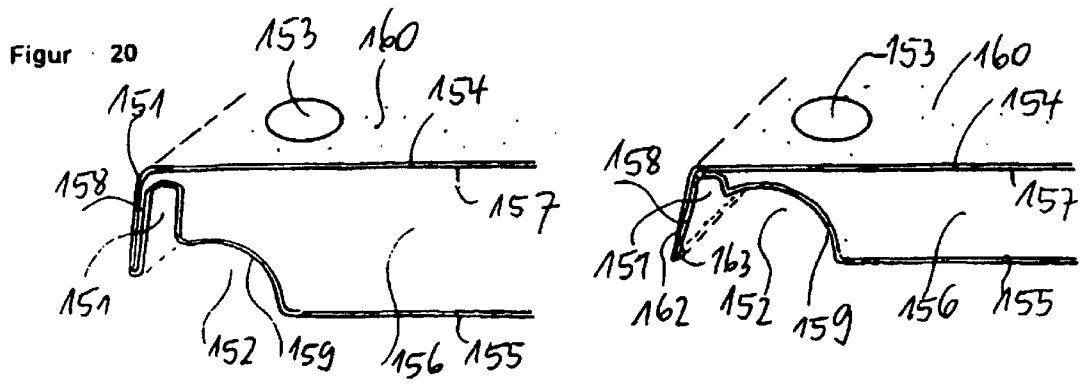

Figuren 23 + 24

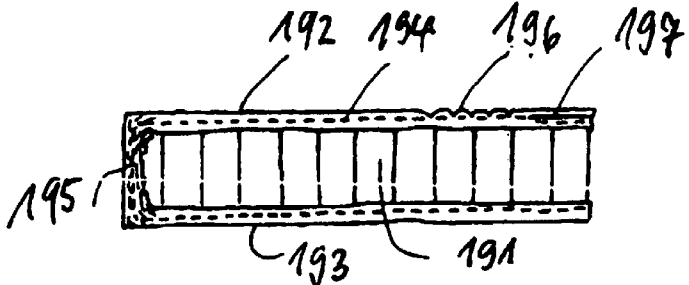

Figuren 25 - 28

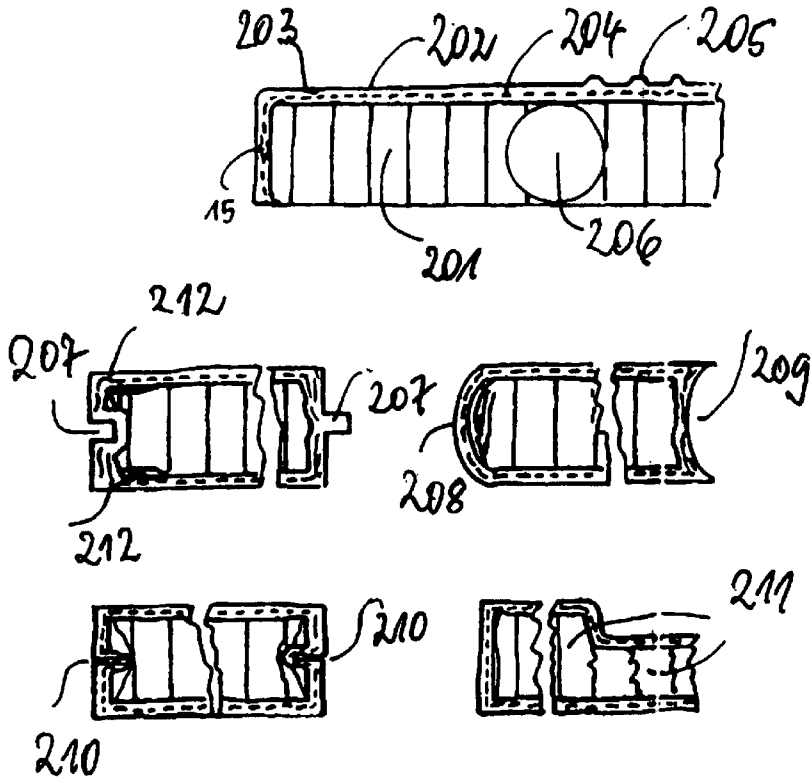

Figur 29

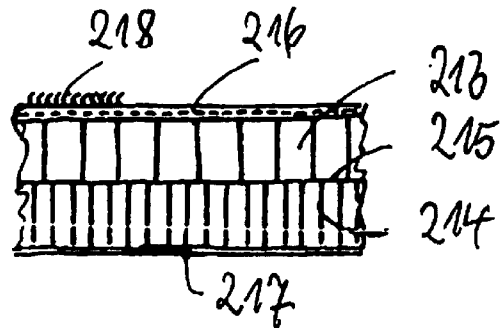

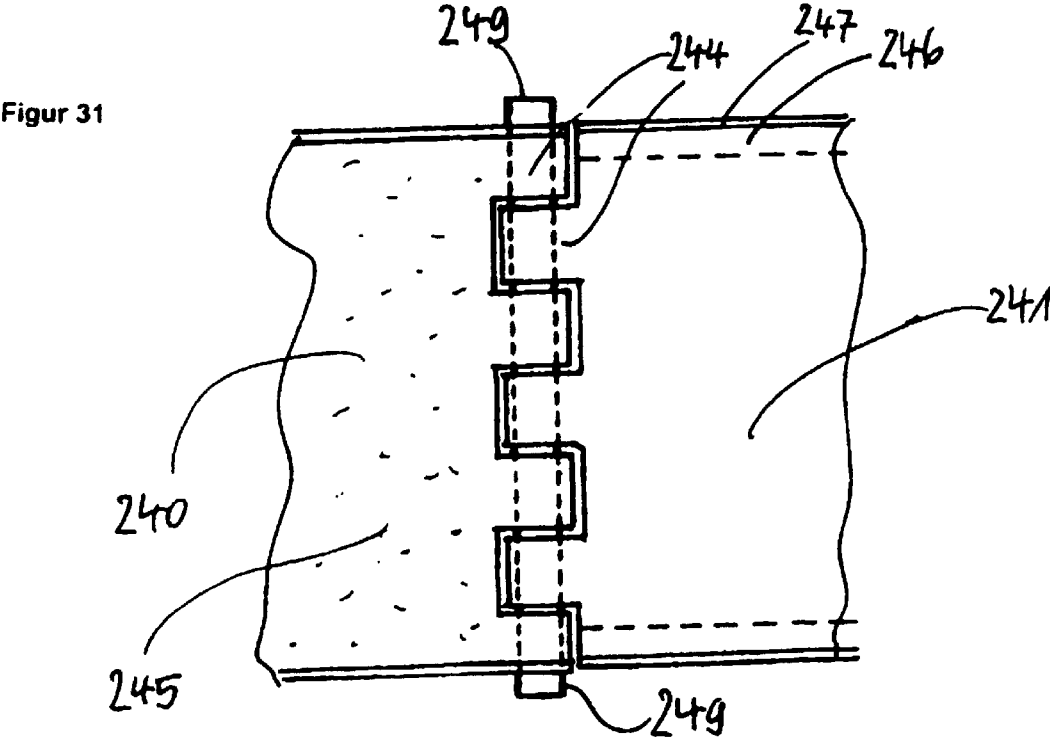
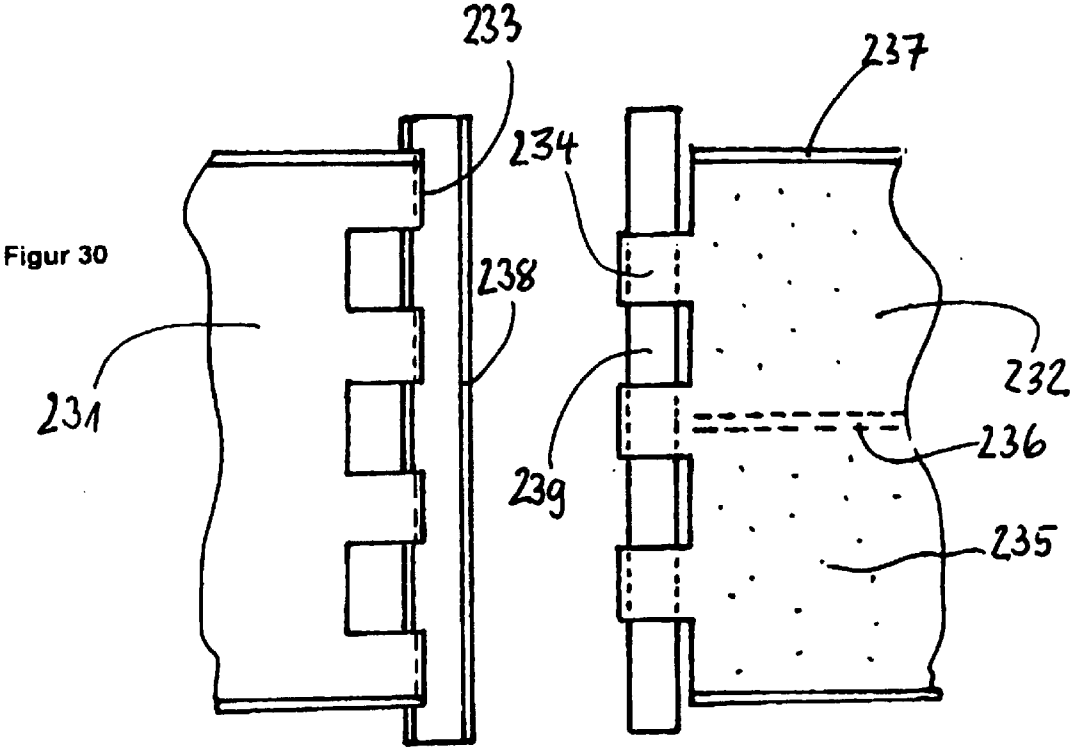
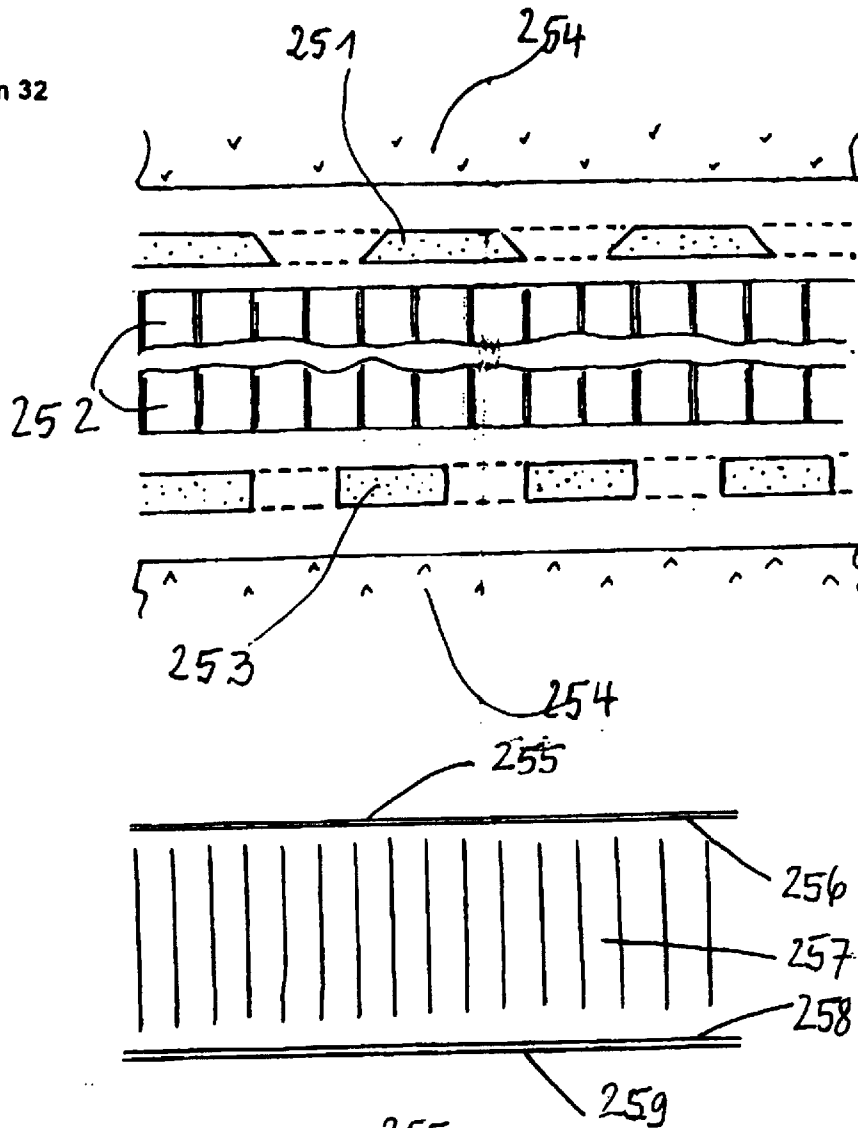
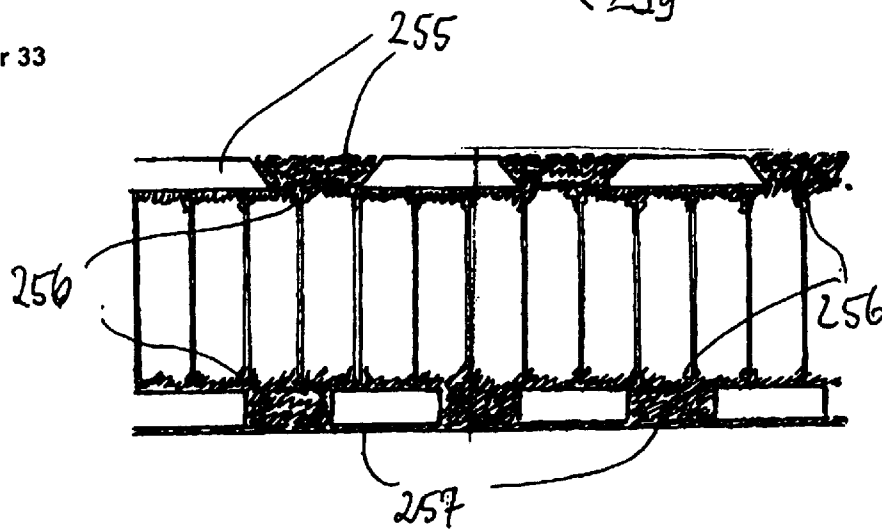

Figure 32



Figur 33



Figur 34

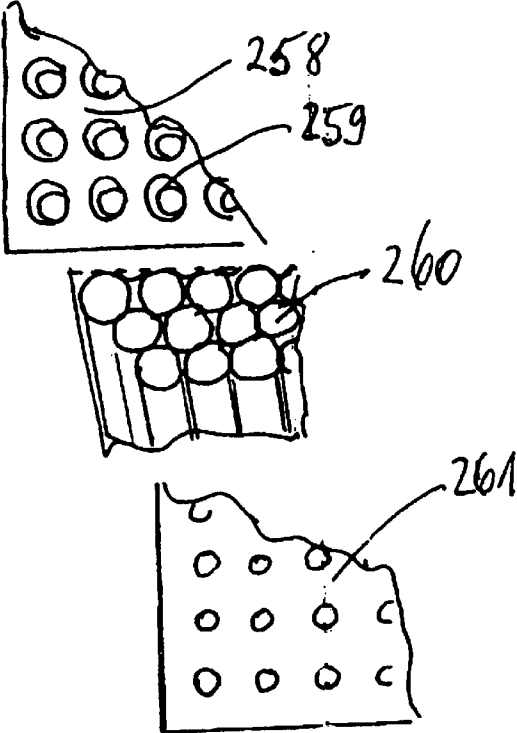

Figur 35

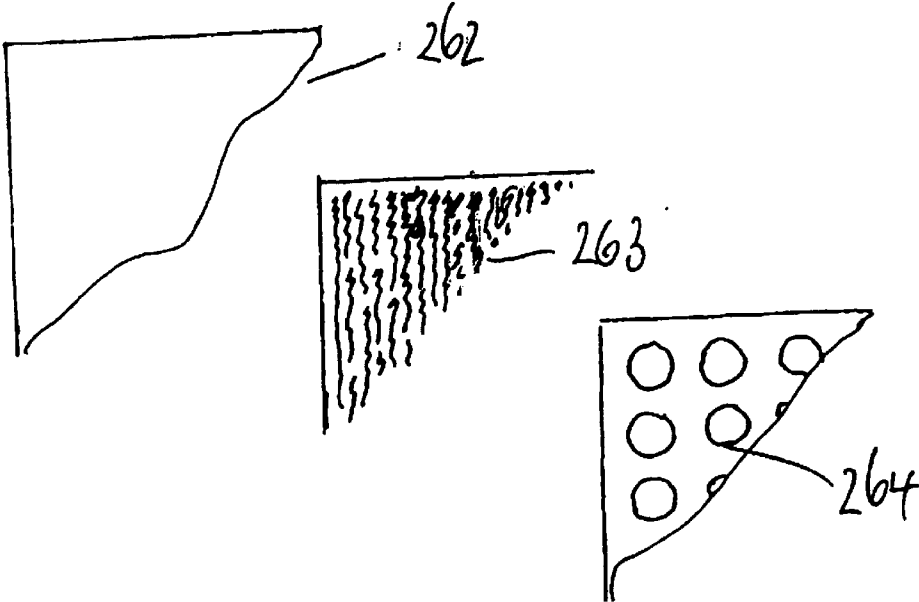

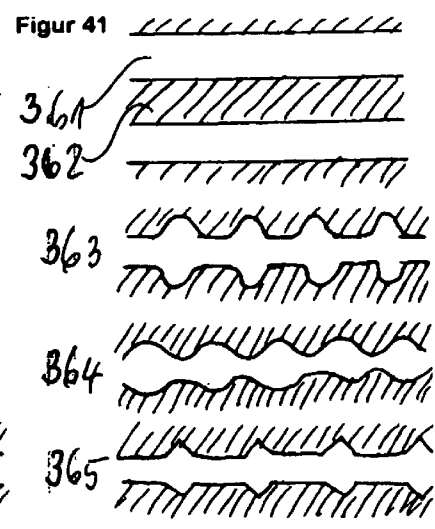
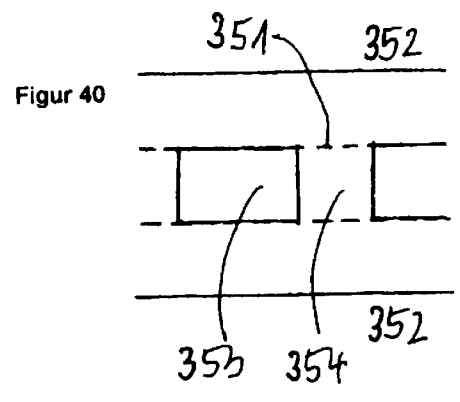
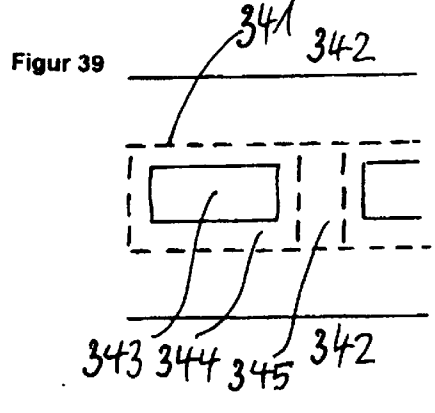
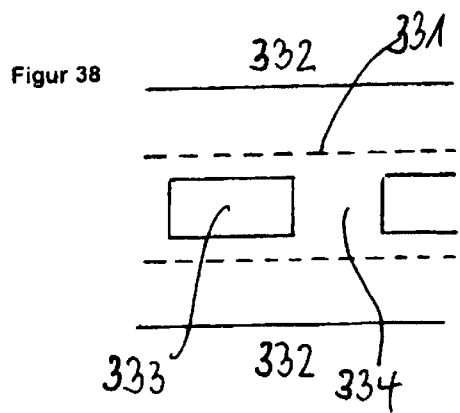
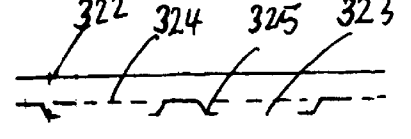
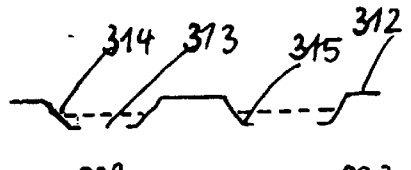
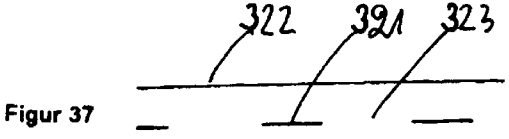
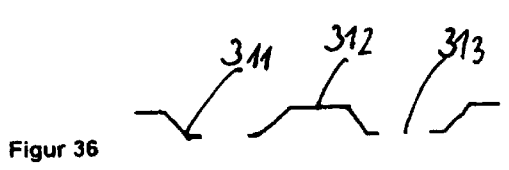

Figur 42

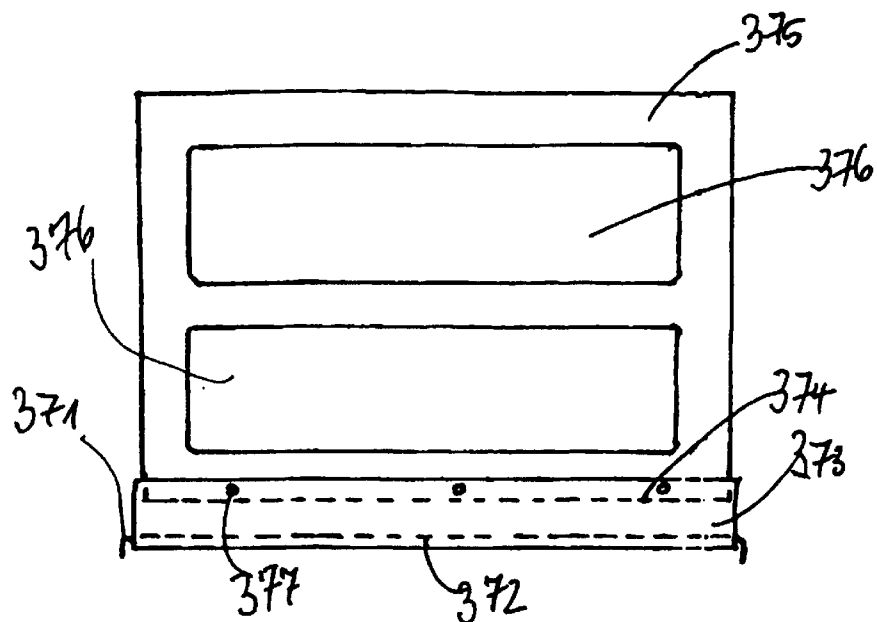

Figur 43

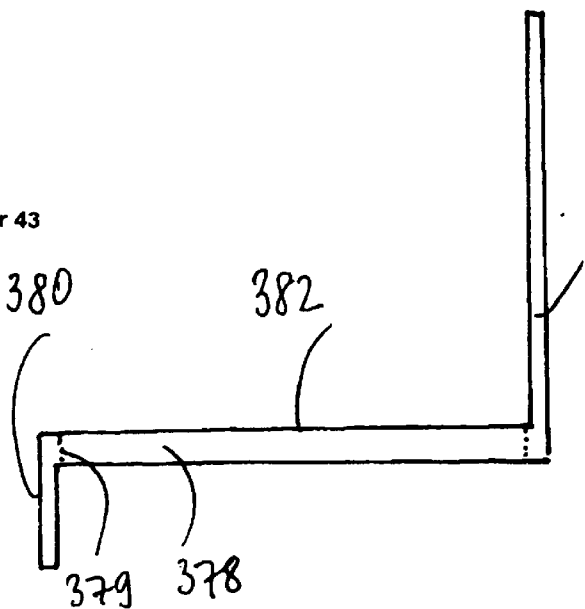

Figur 44

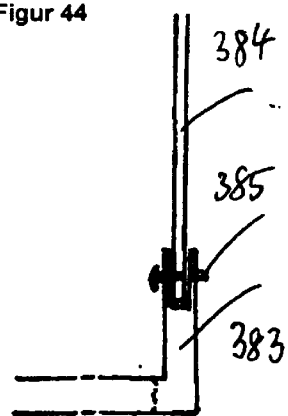

Figur 45

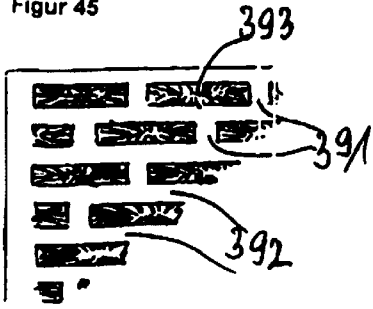

Figur 46

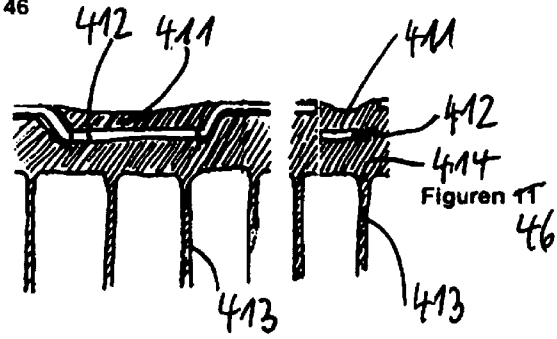

Figur 47

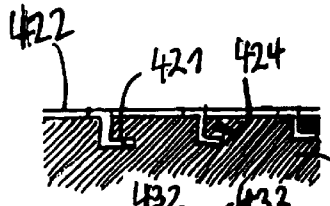

Figur 48

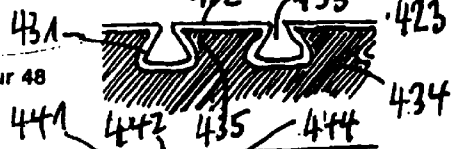

Figur 49



Figur 50

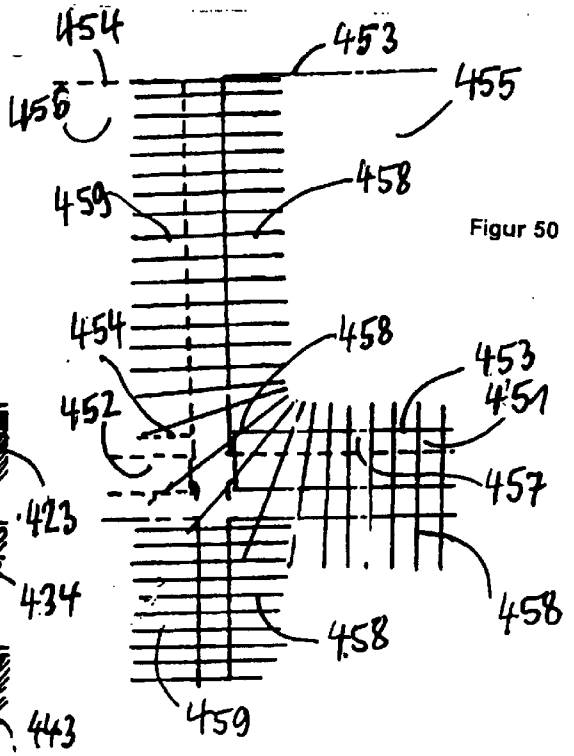

Figur 51

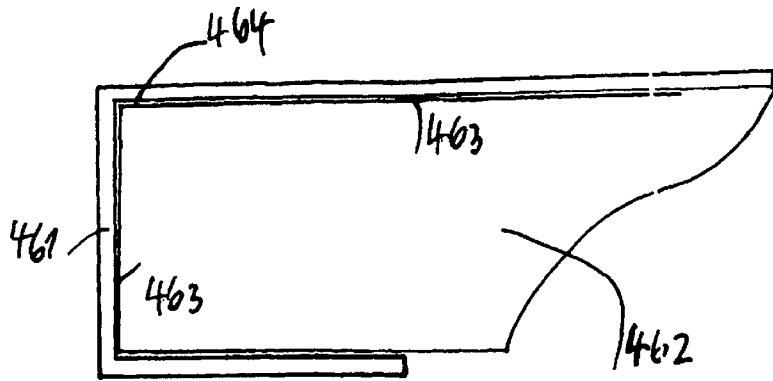

Figur 52

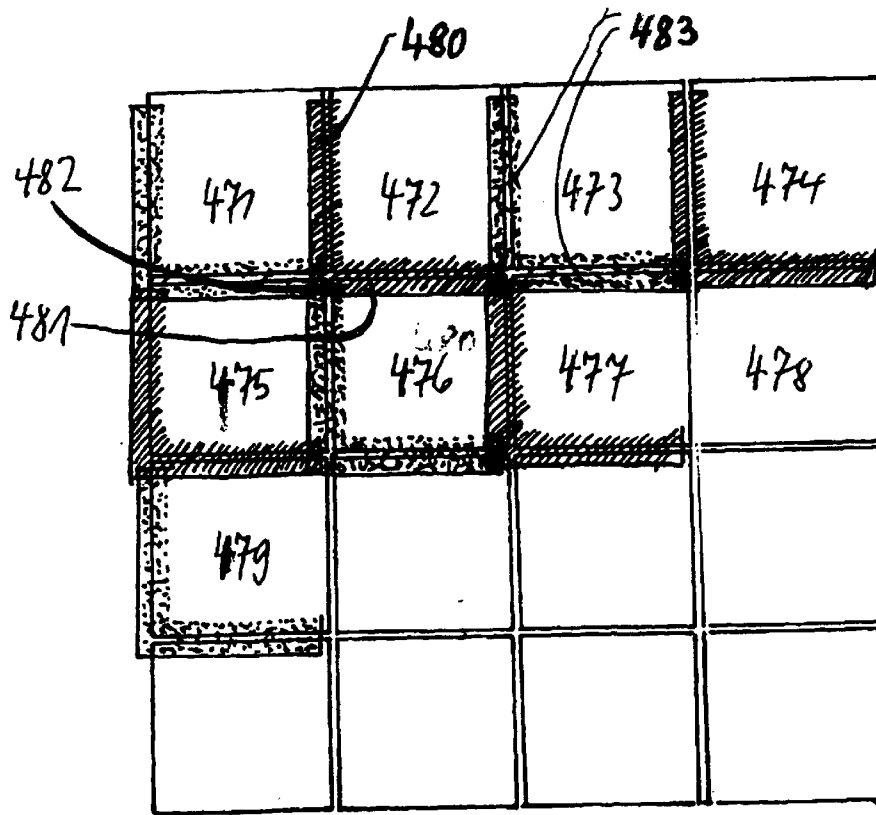

Figur n 53 + 54

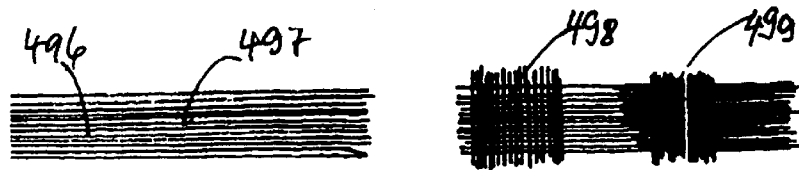

### LIGHT-WEIGHT SCAFFOLD BOARD AND METHOD FOR PRODUCING THE SAME

[0001] Scaffolding plates, planks, or boards are currently manufactured either from massive wood, sheet steel or aluminum, or profiled steel or aluminum, the attempt having been made for many years, in order to save weight, to lay, insert, fit, rivet, screw, glue, weld, or attach in another way thin plywood plates, which have been made weatherproof, in frames manufactured from profiles instead of the profiled sheet metal over the entire length and width.

[0002] In order to then hang the plates in the carrier elements of the rolling or facade scaffolds, which comprise either upright pins or bolts, strips, or round pipes, depending on the scaffolding system, metallic hooks, claws, round grooves, or other suspension fittings are placed, welded, screwed, or attached in another way to the plates or frames.

[0003] There are plates in different lengths of approximately 100, 150, 200, 250, 300, and more centimeters and widths of approximately 15, 30, 45, 60, and more centimeters, which then represent the scaffold when hung next to and one behind another in rows in the individual height levels, usually at the height between floors, in the scaffolding construction. In order to be able to climb a scaffold within the construction, different scaffolding plates within the overall construction each receive climb-through openings within the plate, which may be opened and closed as necessary.

[0004] To secure the craftsmen and to protect the environment against noise and dust and to avoid accidents, 10 to 15 cm high lateral protection parts, currently made of the same material, preferably wood, at the level of the scaffolding plates, as well as railings at the appropriate height and, if necessary, tarpaulins or nets behind them are attached on the sides of the scaffold construction facing away from the building, which then result in the finished scaffold when considered overall.

[0005] Until now, the scaffolding plates, of whatever material, have shared one disadvantage: the craftsmen, who must deal with them daily, consider the plates to be too heavy for laying—particularly at the typical lengths of approximately 250 or 300 cm. The laying and hanging work is still to be done manually, in spite of the possible transport of the plate stack using cranes and other aids.

[0006] Attempts up to this point to use plastic materials such as foams and plates or other compositions and combinations have failed until now either because of the lack of UV and weather resistance, the security of the adhesive bonds applied until now, or the lack of slip safety. The carbolized plywood plates, which are inserted into the plate frames, also do not have a long service life, often rot very rapidly at the connection edges, and thus become a hazard.

[0007] Furthermore, the lightweight plastics often have the property of having too low a modulus of elasticity without reinforcement, so that the sag of the plates, which is fixed at one hundredth of the length for safety reasons, at least in Europe, may only be achieved through significant thicknesses of the plates or through costly reinforcements. The low permissible sag of the plates is required because when the plates, which are often very narrow, are laid next to one another, tripping points arise under load, which result in increased danger of accidents.

[0008] The attempts to introduce frame constructions made of metal, particularly aluminum alloys, to save weight, have made slight progress, but have not generally provided a breakthrough to a light scaffolding plate.

[0009] It is also a problem that there are multiple systems which do not correspond in the suspension and the exact plate lengths, so that manifold plate lengths and widths, plate thicknesses, and types of suspension obstruct the development of new systems and the use of new materials, just like the guidelines of the workers' compensation insurers and the standards. Specifically, until now these have not permitted the use of plastic materials and therefore possibly lower plate thicknesses and greater widths of the plates, having corresponding upward and downward bevels with thinner plate material, so that costly approval processes impair rapid permeation of new developments.

[0010] Furthermore, it is also to be noted in regard to the related art that composite plates and methods for their manufacture from various materials, which comprise a support core as a spacer for the upper and lower cover layers, are known. The support core is typically made of foam, honeycomb, caps, boxes, or other webs, positioned linearly or offset, made of plastic, aluminum, glass, wood or wood fibers, or paper, and the cover layers are made of wood, metal, or duroplastics or thermoplastics with or without reinforcement.

[0011] There are also plates which are cold-glued or in the hot gluing or welding method. Thermal bonds of the cover layers to the support core are described in Patents DE 4208812 A1, DE 19533394 A1, and Utility Models DE 20005948 U1 and DE 29809543 U1. The reinforcement of duroplastic and thermoplastic cover layers with reinforcing fibers or fabrics is also known. Even heating elements between the different layers are used for the bonding (WO 01/19937 A1). This also applies for the bonding to boundary profiles, which are placed on the composite plates, the heating wires being embedded in bands made of hot glue or thermoplastic (Utility Model DE 29809542 U1).

[0012] Light metal honeycombs are glued into composite plates made of sheet steel or aluminum in one or more layers to manufacture planks for scaffold construction (Utility Model G 9207297.6).

[0013] Edge terminuses for composite plates made of thermoplastic are manufactured using hot-press tools by pressing and fusing the upper and lower cover layers and compressing the material in each case into an individual edge (WO 01/19604 A1). These methods are known in the prior art, but are very time-consuming and therefore costly.

[0014] As already described, in general heavy planks made of wood or steel, having the appropriate edge reinforcement or protective sheets, which are processed through impregnation, galvanization, and/or lacquering and the attachment of other safety parts, have been used until now as running surfaces in scaffolds because of the prescribed load possibility. Until now, the lateral protection has been mounted in all cases as a separate lateral protection board on the pipe scaffolding.

[0015] The use of these materials results in the scaffolding boards being very heavy, complex to transport, and only mountable with significant application of force by humans and machines. The somewhat lighter aluminum scaffolding

plates are hardly affordable in regard to price and prone to be stolen. Most of the scaffolding plates used up to this point are specialty waste after they are worn out and are costly to dispose of.

[0016] The present invention is therefore concerned both with the weight problem and with the problem of high costs in the development of a novel manufacturing method, which enables the advantages of easy moldability of the plastic overall, the light weight in relation to wood, steel, and aluminum, and, if appropriate materials are used, the combination of as many individual steps of the production as possible.

[0017] With incorporation of Patent Applications DE 102 14 485.0, 102 15 606.9, 102 16 569.6, 102 17 118.1, 102 21 250.3, 102 25 439.7, 102 26 703.0, 102 40 384.8, 103 00 886.1, and 103 00 888.8, a "light scaffolding plate" is thus represented in this description which, by using plastic honeycomb, foam, or web plates or a mixture thereof with welded, reinforced, or non-reinforced cover layers and hot-molded edge terminuses provides a light scaffolding plate which already comprises holders and covering structure, which almost corresponds in price to the typical wood or steel plank plates, and is completely recyclable without problems, since it is largely produced from a single thermoplastic material or from two materials having melting points significantly deviating from one another, wherein the basic raw materials can be reused.

[0018] The plastic scaffolding plate, which weighs approximately a third of the weight of the wood or steel plank plate, is easy to transport and mount, already has the lateral protection part, which is to be separately mounted, molded on if necessary, and is permanently UV resistant and weatherproof without further processing or impregnation and is slip-proof and safe to walk on in any weather through the structure embossed in the running surface. A directly molded-on lateral protection part simultaneously additionally contributes significantly to the improved static strength of the scaffolding plate without additional costs, further reduces the transport weight to the construction site, and saves significant additional mounting costs.

[0019] As a supplement to the scaffolding plates, typically plates having a climb-through opening are also used, which usually have significantly higher weight than the scaffolding plate, simply because of the frames and the hinges.

[0020] According to the present invention, the flap of such a climb-through opening, the frame, and the hinge, which runs on all or part of the length or width of the frame and the flap, are manufactured from the same material by compressing it, the plate in the typical plate thickness, the frame by fusing the plate material and the cover layers into a static folded profile matching the requirements, if a more cost-effective solution comprised of light metal, preferably aluminum frames placed on the edges of the plate or embedded in the plastic, does not suggest itself because of the length of the plate.

[0021] The hinge of the plate is also permanently welded in or on through a thermal treatment of plate material with or without reinforcement in or on the cover layers of flap and frame, so that this important climb-through plate is also lightweight and has the same height as the typical scaffolding plate and does not have any localized protrusions and tripping points.

[0022] According to the present invention, a revolutionary advantage in relation to typical handling, which saves mounting costs and offers greater safety, particularly in smaller rolling or traveling scaffolds, is also the permanent connection of the four lateral protection parts to the scaffolding board and the incorporation of the climb-through opening into this scaffolding plate. The static values of this frame construction may then additionally be used for the overall statics of such types of scaffolds. The question of drainage arising here is solved through drainage openings introduced into the plate through thermal deformation in the manufacturing procedure.

[0023] The plates may be colored permanently and weatherproof in any color. Identifications and company advertisements may be introduced or applied permanently through nonwoven material print embedded in the plastic, through hot embossing occurring in the manufacturing procedure, or simply through subsequent screen printing or tampon printing.

[0024] Scaffolding plates, planks, or boards are typically hung directly in the transverse girders of the scaffolds or, at lower thickness, are laid, inserted, or riveted in suspendable frames. Scaffolding plates or scaffolding plate frames, depending on the scaffold type, have either screwed, placed, or welded metal sheets having claws or round grooves for suspension form U-profiles, which are open on top, and from pipes, or metal sheets having perforations for hanging from multiple bolts welded or screwed next to one another on the transverse girders.

[0025] Both the massive scaffolding plates made of wood and also lighter plates in perforated sheet steel or aluminum embodiments have, originating from the high material weight of the plate, a weight which requires significant use of energy for the scaffold mounting, particularly for the mounting team, even at half the typical scaffolding width of approximately 30 cm depending on length.

[0026] The plate according to the present invention no longer has this main disadvantage, specifically the high weight of each individual plate, even at double plate width, and is usable for any typical scaffold system having the particular specifically molded suspension devices. It is still a disadvantage here that a different type of suspension is required for every system, which results in multiple productions.

[0027] This last problem is solved in that the plate is manufactured only in one to two different plate thicknesses and mainly in double or triple the scaffolding plate width of approximately 60 or 90 cm and two to three scaffolding plate lengths having only one single suspension deformation of the plate ends. This suspension deformation, which is realized through compression of the plate material, allows precisely fitted hanging by means of the holes from the pin or bolt system, precisely fitted hanging and clamping with the claws in the U-profile of the claw system, and precisely fitted hanging from the pipe system.

[0028] In this case, two typical scaffolding plates currently having approximately 30 cm width because of the high scaffolding plate weight may be combined easily, even at lengths of 250 and 300 cm or more, into a single plate of approximately 60 cm width, or even into significantly larger plates, and these may be compressed in one pass to have a suspension device on the plate ends.

[0029] A further advantage is that these plates may be hot pressed in a typical hot press both individually one after another, as well as, at appropriate width of the press, with multiple rows of plates next to one another having the molded universal suspensions in one work cycle, including the upper and lower cover layers and possibly necessary edge terminuses. In this case, even at greater lengths, statically required additional webs may also be welded at the height of the plate thickness within the support core material, so that the entire scaffolding plate is made of a single, homogeneous material.

[0030] Furthermore, there are the universal usage possibilities and ability to manufacture in large piece counts, both using plate presses and using double-band presses which have appropriate molds.

[0031] Typically, an additional frame of the scaffolding plate may be dispensed with, since it is self-supporting even at greater lengths and matches the statically required conditions, wherein, for this purpose, the structure of the thermoplastic reinforced edge closures and, if necessary, the insertion of an additional, also reinforced web or even, at large plate lengths, a round, square, or rectangular pipe or U-profile made of the same reinforced material or light metal, at the height of the support core therein or at the edge of the support core as an edge terminus, covering all static requirements and particularly the requirements on the modulus of elasticity.

[0032] Furthermore, damage to the scaffolding plate may be repaired easily using the soldering iron and thermoplastic repair material and, if there is a honeycomb as the support core, because of the restriction of damage to a few honeycomb tubes, no danger to the quality or service life of the plate is to be expected.

[0033] Providing a light sandwich plate cover layer by laying a perforated metal plate, which is thermally bonded on one or two sides either solely with one or two thermoplastic layers or also with a thermoplastic support core, so that either a perforated plate having thermoplastic cover layer on one or two sides or a complete sandwich plate having perforated plate cover layers on one or two sides, or even thermoplastic cover layers enclosing a perforated plate are produced in one single hot and possibly cold pressing pass, is considered a further novelty in reinforcing the plastic cover layers.

[0034] The thermoplastic bonding layers from the honeycomb as the support core to the perforated plate may either be laid in the form of thermoplastic films or plates laid between the support core and the perforated plate or, if the support cores or spacers are closed, may be laid, rolled, scattered, or sprayed in powder form during the production process. The use of honeycomb material which already has during the manufacturing process an upper and lower complete or partial hole covering or broad beads made of thermoplastic material at the hole edges and whose molten volume is used to bond the perforated sheet then to the honeycomb core thermoplastically, is even better. Such honeycombs may be manufactured at the required honeycomb plate thicknesses in the direct extrusion method and may also be included at once in the production process.

[0035] With foam material, sufficient material is melted during the hot press process that the permanent bond to the

perforated plate is produced. In any case, the procedure results in a light scaffolding plate having one or two perforated metal cover layers or perforated metal layers enclosed by thermoplastic, which have significant load carrying capacity and provide good and sufficient static values together with the support core.

[0036] The reason that a permanent bond of the perforated plate is possible through the melting process even without it being enclosed by thermoplastic is the presence of edge depressions toward the hole centers in this case, which, during the fusing process, not only non-positively bond the perforated plate material flat in the hot gluing method, but rather also by enclosing the edge beads around the entire circumference over the beads inward toward projecting perforated plate parts of all holes of the plate, without thermoplastic material being able to or having to exit on the top side of the cover layer, unless complete enclosing of the perforated plate with thermoplastic material is desired.

[0037] In this way, it is possible to dimension the thickness of the bonding layer low if necessary and save thermoplastic cover layer material with the height of the perforated plate or with the height of the perforated plate and the projecting edge depression.

[0038] The perforated metal cover layers may also receive structures on their surface even during manufacture and may be provided externally with raised or depressed structures during pressing on one or both sides, e.g., even with an anti-slip covering. Furthermore, a colored design may also be produced here through permanent coloration of the thermoplastic material visible through the perforation, or even of the perforated metal plate. Therefore, for example, in the case of with company products, permanent identification is possible, which is good as theft protection and also for advertising purposes.

[0039] An interesting solution of the object in the case of the perforated sheet metal solution is laying the desired design or lettering in the desired color as a plastic film or colored nonwoven material, which bonds to the remaining cover layer on the surface upon heating and is visible through the holes.

[0040] The openings of the perforated metal plates may have different shapes, such as round holes, oval or box-shaped holes, oblong or square holes, with and without round corners or a mixture thereof, crescent, cross, or diamond shapes, may be positioned in linear or offset rows, diagonally offset rows, or similar way, the relative free hole area making up approximately half of the plate, but also more or less.

[0041] With all hole shapes it is possible to manufacture edge depressions or conical edge formations running toward the later support core, so that the thermoplastic material upon the hot pressing lays around the existing beads or hole edges tapered toward the hole center during the fusing process and therefore bonds the perforated metal plates to the thermoplastic material immovably and homogeneously in a formfitting way.

[0042] Depending on the arrangement of the holes relative to one another, if the hole edge configuration is dispensed with, the bonding of the thermoplastic material from the top cover layer to the cover layer lying below the perforated

plate and, via the latter or even directly from the top layer, a thermoplastic bond to the support core is provided via the perforations.

[0043] Although the perforated metal plate has a permanent seat through the hole edge formation or within the thermoplastic bonding or cover material, for special strains the bond between perforated plate and thermoplastic may also be optimized by a special treatment of the cover material, for example, using a primer (adhesion promoter) or other roughening treatment even during the rolling procedure, so that even strong bending and impact strains of the light scaffolding plate may be permanently absorbed.

[0044] Using the perforated metal plate, which has a high bending strength even at low material thickness and with low weight in the composite, even with low overall panel thickness, peak values may be achieved which otherwise can only be achieved through massive material use having high weights and panel thicknesses.

[0045] When the nonpositive bonding of the metal cover layer may be dispensed with in the event of later lower load of the light scaffolding plate, the direct bonding of the metal cover layer, which is primed or provided with an adhesion promoter, to the thermoplastic support core suggests itself. A weatherproof bond also arises here and, if textured sheets are used, the necessary slip safety of the plates may also be achieved, which offers sufficient safety with and without an additional structured plastic layer possibly applied during the pressing procedure. The previously cited deformations of the plates are also possible here.

[0046] Further additives in the thermoplastic material of the cover layers, but also the support core, result in properties which the base material does not necessarily have. Additives such as short or long glass fibers, glass balls, talcum, wood flour, wollastonite, zinc oxide, polyester fibers, metal powder, mica, calcium carbonate, and the like result in greater strength, higher modulus of elasticity, and influence the modulus of bending and creep, hardness, dimensional stability in the heat, tearing and tensile strength, compression resistance, dimensional stability, density, fatigue strength, thermal conductivity, and melting viscosity, reduction of stretching, impact toughness, impact strength when notched, creep tendency, shrinkage, thermal expansion, abrasion resistance, UV and weather resistance, melt flow index, etc.

[0047] In this cover layer according to the present invention, the light scaffolding plates may also have lateral parts molded on directly through beveling downward or upward or in another way in any arbitrary length, even having recesses, laterally or all around on top, on the bottom, or on one side on top, and on the other side on the bottom, so that finished products arise either already in the hot pressing process or in a second deformation process.

[0048] The static absorption of the load forces is performed in the solution of the object according to the present invention described up to this point primarily through the two cover layers bonded to the support core and their reinforcement and/or the perforated metal sheets via the appropriate dimensioning of the height of the support core. In the prior art, frame plates having thinner floors inserted or placed thereon or the wood planks, this primarily occurs via the dimension of the height of the metal frames or the planks.

[0049] Achieving the static object of absorbing the load forces in a thin scaffolding plate without using frames may also be realized, as described according to the present invention, by incorporating the 10 to 15 cm high lateral parts, which are prescribed in scaffolding anyway, as a supporting web on one side and an upward or downward bevel at 5 to 10 cm height on the other side, without the thickness of the plate being expanded unnecessarily for this purpose. The cover and lateral part thicknesses may also be kept very low, which also has an effect on the weight per square meter.

[0050] The only problem is the stackability of the plates both for storage and for transport, which is solved not only with upward and downward bevels of lateral protection parts and supporting web, but also in regard to the possible alternative of upward bevels on both sides. In both cases, only a slightly diagonal stacking is necessary in order to produce a vertical stack; transverse storage is also possible without requiring significantly larger areas, since the storage or transport area for the lateral parts is saved.

[0051] In addition, the time savings during loading and particularly during scaffold mounting is to be noted, which is not insignificant, so that the handling and mounting costs may be significantly reduced once again.

[0052] Accordingly, a significant weight reduction is also achieved. The light scaffolding plate weighs 3.5 kg per running meter of scaffold length at a plate thickness of up to 15 mm, including lateral parts, and only 4.2 kg at a plate thickness of 20 mm, i.e., a reduction to a fraction of the weight in relation to current typical scaffolding plates. This is also true at other dimensions. The weight reduction is even higher considering that the additional lateral protection parts to be transported or mounted are dispensed with.

[0053] Since, in addition to the lower lateral protection part, further planks or other protection parts up to a height of 100 cm may be necessary on the side of the plate facing away from the building, it is also possible to mold the lateral protection part up to this height onto the light scaffolding plate, without the ability to stack them suffering because of this. However, it is also possible to place the extension of the lateral protection part in an independent part and attach it removably using securing pins or other securing measures.

[0054] This may even be extended in such a way that such a placed lateral protection part shields a large part or the entire side of a complete scaffolding panel facing away from the building. According to the present invention, the light scaffolding plate or parts thereof are made of colorless, thermoplastic material which is transparent to light.

[0055] In order to also achieve dust-tight complete coverage, even in the area of the connection points to the next plates, the outer cover layer of the lateral protection part may be equipped with a projecting overlap to the particular neighboring lateral plate, or even upper or lower plate, which is set to elastically and permanently press on the other plate. This is permanently possible with pre-tension using an appropriately oriented and hot-pressed fiberglass-reinforced material such as the plate.

[0056] The lateral protection parts and possibly placed lateral parts may particularly also be provided with an inscription permanently introduced in the thermoplastic layer, also for advertising purposes and for identification,

whether by printing a nonwoven material or by attaching a hot-pressed structure or something similar as already described.

[0057] In addition to the advantages and possible solutions already cited, in addition to the perforated metal sheet solution, there are also types of sheet deformation which provide a tight bond of the thermoplastic bonding or cover layer to the thermoplastic support core. Thus, for example, a metal plate may be provided with longitudinal continuous depressions or beads or may receive hook-like or claw-like shoulders, distributed on the sheet surface, toward the support core by means of efficient welding methods.

[0058] It is also possible to provide sheets having thinner material thickness with depressions or beads or other structures and attach C-shaped, L-shaped, or U-shaped beveled webs to the two lateral parts, or to configure these sheets in a pocket-shape and glue closed support cores made of honeycomb or foam having closed pores into these sheet sleeves and subsequently provide both ends with the required suspension fitting such as round grooves, claws, or holes or by deformation in other ways.

[0059] In the method for manufacturing the "light scaffolding plate", a special layering must be performed during the hot and cold pressing procedure because of the different properties of the materials, which is reflected in the corresponding patent claims.

[0060] Considered overall, the present invention enables, in addition to saving weight-related transport costs, saving significant mounting and handling costs, and a novel type of scaffold planking, securing, and design. The typical dust protection planking using film which is easily damaged and typically usable only a few times or even only once, may also be manufactured more stably and cost-effectively through reusable lateral cover plates.

[0061] The "light scaffolding plate" according to the present invention having a perforated metal cover layer particularly becomes a homogeneously bonded plate if complete enclosing of the plate with hole edge depressions, which may be enclosed by the thermoplastic bonding layer, is dispensed with. In this case, in addition to the normal hole edge depressions of a sinkhole perforation or a sinkhole perforation on both sides, lobe holes, slotted bridge holes, projecting holes, or other types of holes in which the thermoplastic material of the cover or bonding layer engages behind the perforated sheet at multiple points without engaging the entire surface of the cover plate, may be applied, in particular in the form of round holes, square holes, or oblong, hexagonal, or polygonal holes, diamond holes, triangular holes, star-shaped holes, or key holes, having rounded corners or being angled.

[0062] The individual openings or holes of the sheets may be applied to the plate or to the strip made of steel, aluminum, or other metal or duroplastic, which is intended for later cutting, through stamping, drilling, milling, sawing, or other cutting, combinations thereof, or even other methods in all possible cell sizes.

[0063] In order to manage with a perforated metal plate material which has only a low material thickness, the possibility exists of using thermoplastic plate or film material which has tightly arrayed endless glass fibers across the entire plate length. This material is also usable in multiple

layers and, laid alternately in layers longitudinally and transversely, may have identical results as fabric reinforcement.

[0064] For the manufacturing of the plates in the plate or band press, for a flexible terminus or a partial depression of the thermoplastic surface in the perforated region to below the sheet upper edge, to produce a structure for slip resistance, for example, the hot press and/or the cold press or a flat plate tool which travels through both presses with the pressed product or is passed through, may be designed with a heat-resistant, rubber-like, compressing and subsequently reexpanding, separable layer over the entire area, which causes the thermoplastic material of the bonding or cover layer to be pressed back in the direction of the bottom of the perforated plate at the perforated points, so that the perforated plate top remains free of material. This also results in a savings in material, in addition to other effects.

[0065] A further way of producing the light scaffolding plates from only one single material, both for the cover layers and for the support cores and all required reinforcing and secondary parts, is to use a homogeneous polymer monolith.

[0066] A method for manufacturing a homogeneous polymer monolith, in which a structure of oriented polymer fibers is kept at elevated temperature, approximately 5-2° C. below the melting point, and a part of the polymer is melted and subsequently compressed or compacted within a predefined time window and subsequently cooled back to the ambient temperature by leaving it in air, is disclosed in EP 0531473 B1. These are melt-spun homopolymer or copolymer fibers, which, as the compacted product, then have a density of at least 90% of the original fiber density.

[0067] An additional invention is thus possibly dispensing with fiberglass or other reinforcement using similar reinforcement materials or the use of perforated metal sheets as the top covering in light plates, which do not match the thermoplastic main material of the plates and only contribute to stiffening the plate, by using a thermoplastic material specially prepared according to the above-mentioned method. This is performed by using a multilayered thermoplastic material, made of the thermoplastic main material and altered with bidirectional molecular orientation, that provides a significant savings in weight for the cover layers from highly-oriented materially-identical reinforcement elements with the same stiffness and strength as in a fiberglass reinforcement. By dispensing with a non-thermoplastic reinforcement material, absolute recyclability of the entire light plate is provided.

[0068] A further savings in weight results at high load strains on the plates even if the perforated metal plates, having pocket-like or similarly depressed holes, are used as rivet-like bonded top coverings or even embedded as simple perforated sheets in the cover layers, even significantly thinner than otherwise required.

[0069] Furthermore, the use of this material for the support cores as well, i.e., for the honeycomb, cap, box, or web manufacture, is also novel. In this case, for example, in the honeycomb, the honeycomb cross-section or, in other support components, the spacing of the individual spacing bodies to one another may be doubled to quadrupled, without the carrying capacity of the plate being impaired. It

is also possible using this prepared material, whose structure has been changed, to make the material thickness lower and therefore the light plates even lighter while maintaining the typically required dimensions.

[0070] By manufacturing the support components such as tubes (also connected into honeycombs), caps, webs or corrugations, boxes, or the like in the deep-drawing or hot-pressing methods, for example, while simultaneously increasing the strength, significant material savings related to weight may be achieved and it is then possible above all, during the further processing of the material into the complete light plate while largely maintaining the necessary deep-drawing or hot-pressing temperature, subsequently to thermally press the cover layers made of the same material with the required pressure on the support core, even without nonwoven material or adhesive intermediate layer, and simultaneously or subsequently to provide the pressed part with the required structures, e.g., edge closures or a slip-proof structure and fittings, molded from the same material.

[0071] The additional thermoplastic material that remains in identical or significantly greater thickness than the material of the actual support body during the deep-drawing or hot-pressing procedure of the tubes, caps, webs or corrugations, boxes, or the like on the top or bottom, is then simultaneously used to reinforce the cover layers and is simultaneously used here in a linear longitudinal or transverse orientation for further, significant improvement of the stiffness and bending resistance and thus makes it possible to achieve an optimum material use, that is favorable in regard to weight and naturally affects the price.

[0072] A further consideration according to the present invention is to find a simple and cost-effective method technology, which allows a tight bond of the perforated metal plate to a thermoplastic and a statically active support layer as a support core in a simple way.

[0073] In the way described in the following, in one manufacturing pass, the support core, which is comprised either of known thermoplastically deformable plastic honeycombs, tubes, caps, boxes, webs, corrugations, or similar structure plates or even plastic foam plates, is hot pressed directly with one or two perforated sheets without an intermediate layer and cooled under pressure, so that the support core material itself deforms into the shapes required for the tight bond.

[0074] All properties which are expected from the cover layer that is visible later, such as color, weather, temperature, and UV resistance, elasticity, tensile and bending properties, as well as thermoplastic deformability under pressure, etc. are already provided here by the thermoplastic support core, which also positively affects the strength and bending properties and particularly the overall weight in large part.

[0075] An additional, special property of the perforated metal sheet, specifically the existing sinking or depression of the holes and therefore the possibility of a smooth surface of the cover layer, which then appears made of metal and plastic, is also represented here by the uniform, perfect tight clawing and bond of the sheet metal to the plastic material in the form of multiple rivet heads.

[0076] Any final thickness of the light scaffolding plate may be determined through the height of the support core before the pressing step. Inaccuracies and tolerances of the

support core plates are compensated by predefining the final height, as are slight inaccuracies in the flatness of the perforated metal sheets or the burrs formed when perforating. Furthermore, by increasing the height of the support core material, the thickness of the bonding thermoplastic layer and therefore the stiffness and bending strength, i.e., the stability of the finished plate, may be influenced.

[0077] Through the permanent inclusion of the metal in the chemically resistant plastic in the perforated region, it is even possible to perform subsequent finishing of the metal at the visible surfaces, such as anodizing in the case of aluminum, so that protecting these surfaces during pressing may also be dispensed with here.

[0078] By selecting the hole shapes and sizes and their linear or offset arrangement in the perforated metal sheet and also through the depth of the hole sinking, both the hole sizes of the honeycombs, boxes, or tubes, and the spacing of the webs or caps, etc., in the support core may be taken into consideration completely and a tight, permanently stable bond may always be achieved. The weight of the finished plate may also particularly be tailored to the application, so that optimum results may be achieved in regard to the lightness of the plates.

[0079] The light scaffolding plate also has further possible uses as a light plate. It is suitable not only as a scaffolding plate, but rather also as a floor and lining plate and for multiple other plates and supporting profiles which are loaded in regard to stiffness and bending resistance. Thus, such plates may be used as floor plates, shelves, insulation plates, sound protection plates, and plates for other areas of application, which must withstand static strains and also suffice for decorative purposes.

[0080] A further important function may be assumed by the plate as a vacuum panel, by using a gas-permeable support core and a gas-impermeable film which encloses it completely.

[0081] Methods for manufacturing the plate have already been discussed at different points of the description. However, the individual method steps will be described once again in the following:

[0082] In order to manufacture, in a stationary plate press, the "light scaffolding plate" from a thermoplastic support core or other spacers, which determines the color of the plate, in over-sized thickness and necessary width and length in the middle, over which only a sheet metal, a perforated sheet metal, or a sinkhole perforated sheet metal is laid on top and bottom, in a single hot-pressing and cold-pressing pass using temperatures for heating and cooling, which are tailored to the different melting points of the materials and the material thicknesses, in direct contact with the hot and subsequently cold plates of the press and/or the possibly required structure, it is necessary to lay the perforated sheet metal on a structured separating film with the sinking of the holes in the direction of the side facing away from the lower press plate and lay the support core thereon in an over-sized thickness. The second perforated sheet metal is then laid on top with the hole sinking in the direction of the support core and pressed with the additional structured separating film laid in the direction of the plate and thermoplastically bonded to the panel, whose later thickness and color design has been previously determined. In the subsequent cold-

pressing procedure, the plate receives the final, sunken or raised surface structure and shape and, if corresponding molding tools are used, additional molded parts such as claws, grooves, and other suspension fittings, closures, reinforcements, inserts, and web inclusions, edges, and holes.

[0083] When additionally using a thermoplastic cover layer between perforated sheets and support core, the method is analogous with the difference that the support core has a thickness closer to the final thickness of the plate with its cover layers and only the cover layers are placed on top and bottom between the perforated sheet metal or sinkhole perforated sheet and the support core.

[0084] To apply inscriptions, prepared lettering and designs, made of plastic film or nonwoven material, or plastic film or nonwoven material which reproduces their colors are additionally laid directly above the lower or below the upper perforated sheet layer or sinkhole perforated sheet layer before the pressing step

[0085] In order to press "light scaffolding plates" in multiple units all at once in one pressing pass using a stationary press, these are to be laid next to or one behind another until the entire available pressing area is filled up and are to be hot pressed and cooled simultaneously.

[0086] During the hot pressing, the liquid thermoplastic compound generating from the thermoplastic cover layer and/or the surface of the support core flows through the holes of the perforated sheet metal or single perforated sheet metal, the depressions in the plate are filled, and during the subsequent cooling, the solid rivets or connection pins to the flat plastic layer required for the bodily formfitting bond or the clawing arise.

[0087] An improvement of the stability, the modulus of elasticity, and the UV and weather resistance of the plate is influenced by a greater thickness and change of the material properties of the cover layer and/or of the support core and by enlarging or reducing the hole size and/or sinking the holes and/or through offset arrangement of the holes in the direction of the later strain of the scaffolding plate.

[0088] To make the manufacturing method more efficient, a continuously running extruding process for the manufacture of the honeycomb support core, with or without flattened plate surface, or a continuously running deep-drawing procedure for a support core in tube, cap, box, web, corrugated, or similar structure is carried out upstream. Furthermore, introducing slots in the honeycomb structure may be carried out upstream. This sequence may be performed in a single, continuously running method with subsequent hot pressing of the cover layers of identical or different thickness from the coil or as a plate in the continuous or plate press cycled method, with or without intermediate layers of nonwoven material, textile, or adhesive layers possibly also from the coil, with or without the application of depressed or raised structures for surface coatings, made of structured separating film positioned or entrained between the materials and the rollers or press plates, such as a slide protection structure, and/or perforated sheet metal or sinkhole perforated sheet metal or similar layers, notching slots, holes, or the like, the subsequent edging and fitting molding and the trimming or cutting to length while maintaining or introducing the required, exactly controlled melting temperature at the surfaces to be fused and material underneath to be

fused and subsequent cooling in the subsequent cold press, each under electronic or manual control and precise consideration of the temperature window required for the material.

[0089] The manufacture of a "light scaffolding plate" having a fiber-reinforced cover layer is performed in the same way, only the fiber-reinforced thermoplastic cover layer being introduced instead of the normal thermoplastic cover layer and the perforated sheet metal or sinkhole perforated sheet metal being dispensed with.

[0090] The identifications of the individual components and functions of the plate in the individual steps of the production method are found in the supplemental pages "on the drawing".

Light-Weight Scaffold Board and Method for Producing the Same

#### ON THE DRAWING

[0091] FIG. 1 light plate in section

[0092] 01 top cover layer

[0093] 02 support core

[0094] 03 lower cover layer

[0095] 04 fusing of cover layer/support core

[0096] 05 downward bevel of edge terminus

[0097] 06 fusing of edge terminus/cover layer

[0098] FIG. 2 perforated metal sheet top covering (sections)

[0099] 11 visible surface of the perforated metal sheet top covering

[0100] 12 perforated metal sheet

[0101] 13 sinkhole having hole edge depression

[0102] 14 thermoplastic layer, positioned sunk

[0103] 15 thermoplastic layer

[0104] FIG. 321 visible surface of the perforated metal sheet top covering

[0105] 22 perforated metal sheet

[0106] 23 sinkhole having hole edge depression

[0107] 24 thermoplastic layer at height of perforated metal sheet surface in one plane

[0108] 25 thermoplastic layer

[0109] 26 possible slide protection structure

[0110] FIG. 431 visible surface of the perforated metal sheet top covering

[0111] 32 perforated metal sheet

[0112] 33 hole edge depression on both sides

[0113] 34 thermoplastic layer at height of perforated metal sheet surface in one plane

[0114] 35 thermoplastic layer positioned depressed

- [0115] FIG. 541 top perforated metal sheet
- [0116] 42 support core
- [0117] 43 bond of support core to cover layer and enclosed edge depression
- [0118] 44 bond of support core to cover layer and perforated plate enclosure
- [0119] 45 bond, similar to flat rivets, of thermoplastic to perforated metal sheet edge depression
- [0120] 46 possible structure
- [0121] 47 plate-like surface of the support core
- [0122] 48 honeycomb web having bead
- [0123] 49 bottom perforated metal sheet
- [0124] FIG. 651 perforated metal sheet
- [0125] 52 conically tapering narrowing of the hole (pocket)
- [0126] 53 thermoplastic bonding material
- [0127] FIG. 754 perforated metal sheet
- [0128] 55 hole
- [0129] 56 thermoplastic bonding material
- [0130] 57 enclosure with thermoplastic material
- [0131] FIGS. 8+9 types of perforated metal sheets bonded to thermoplastic
- [0132] 61 section through lobe perforation
- [0133] 62 section through projecting perforation
- [0134] 63 top view of lobe perforation
- [0135] 64 top view of lobed web
- [0136] 65 top view of projecting perforation
- [0137] 66 top view of upright projection
- [0138] 67 offset arrangement of lobe hole lines
- [0139] 68 lobed web
- [0140] 69 thermoplastic layer positioned depressed toward web
- [0141] 70 thermoplastic layer in plane toward upper edge of web or projection
- [0142] 71 thermoplastic layer hot molded under pressure
- [0143] 72 upright projection
- [0144] FIG. 1081 section through slotted bridge perforation
- [0145] 82 section through slotted bridge
- [0146] 83 section through perforated sheet surface
- [0147] 84 thermoplastic layer positioned depressed toward slotted bridge
- [0148] 85 protruding slotted bridge
- [0149] 86 thermoplastic material
- [0150] FIG. 1191 top view of offset slotted bridge arrangement
- [0151] 92 slotted bridge
- [0152] 93 perforated metal sheet
- [0153] 94 section through elevation of slotted bridge
- [0154] FIG. 12 simple light scaffolding plate in construction, section
- [0155] 101 support core
- [0156] 102 top cover layer
- [0157] 103 bottom cover layer
- [0158] 104 edge boundary terminus
- [0159] 105 thermoplastic material having highly-oriented reinforcement elements
- [0160] 106 fusing of boundary terminus
- [0161] 107 structure for slide protection
- [0162] FIGS. 13+14111 fused-on deformation for suspension of scaffolding plate
- [0163] 112 fused-in hole having material compression all around
- [0164] 113 fused-on U-profile
- [0165] 114 material compression
- [0166] FIGS. 15+16 scaffolding plate before and after the downward beveling, different thicknesses, section
- [0167] 115 compressed support core
- [0168] 116 compression of the support core in the downward bevel region
- [0169] 117 normal support core thickness
- [0170] 118 final support core compression in the downward bevel region
- [0171] FIGS. 17+18 scaffolding plate having four lateral protection parts and climb-through flap, side views, cross-sections
- [0172] 131 lateral protection part upright
- [0173] 132 scaffolding plate
- [0174] 133 boundary terminus
- [0175] 134 climb-through flap open
- [0176] 135 hinge made of thermoplastic material, elastic and returning
- [0177] 136 frame for flap, compressed
- [0178] 137 handle hole
- [0179] 138 drainage slots
- [0180] FIG. 19 top view
- [0181] 141 lateral protection part
- [0182] 142 drainage slots
- [0183] 143 climb-through flap
- [0184] 144 frame for the flap
- [0185] 145 climb-through hole
- [0186] 146 hinge made of thermoplastic material, elastic and returning

- [0187] FIG. 20 suspension fittings, thicker and thinner plate
- [0188] 151 claw
- [0189] 152 round groove
- [0190] 153 perforation
- [0191] 154 top cover layer
- [0192] 155 bottom cover layer
- [0193] 156 support core and spacers for cover layer
- [0194] 157 pressure fusing with cover layer
- [0195] 158 deformation of support core and cover layers into homogeneous claw
- [0196] 159 deformation of support core and bottom cover layer into round groove
- [0197] 160 slip-proof structure
- [0198] 161 perpendicular arrangement of the claw
- [0199] 162 angling of the web of the claw
- [0200] 163 deformation of the claw to support the pipe suspension
- [0201] FIG. 21 scaffolding plates having upward and downward bevels, view of plate end of thin plate before stacking, thick plate after stacking
- [0202] 171 suspension claw or groove
- [0203] 172 stackability
- [0204] 173 displacement guard
- [0205] 174 upward bevel lateral protection part
- [0206] 175 downward bevel lateral part
- [0207] 176 cover surface upper edge
- [0208] FIG. 22 rear lateral part, view
- [0209] 177 suspension claw
- [0210] 178 displacement guard
- [0211] 179 upward bevel lateral protection part
- [0212] 180 cover surface upper edge front lateral protection part, view
- [0213] 181 suspension claw
- [0214] 182 upward bevel lateral protection part
- [0215] 183 cover surface upper edge
- [0216] FIGS. 23+25 light scaffolding plate, special forms
- [0217] plate structure having cover layer on both sides
- [0218] 191 support core
- [0219] 192 top cover layer
- [0220] 193 bottom cover layer
- [0221] 194 highly-oriented thermoplastic material
- [0222] 195 edge boundary terminus
- [0223] 196 structure sunk
- [0224] 197 printed nonwoven material, colored film plate structure having cover layer on one side
- [0225] 201 support core
- [0226] 202 top cover layer
- [0227] 203 highly-oriented thermoplastic material
- [0228] 204 boundary terminus having slightly rounded corners
- [0229] 205 structure raised
- [0230] 206 inserted reinforcement pipe
- [0231] FIGS. 25-28 types of edge terminus
- [0232] 207 tongue and groove
- [0233] 208 positive rounding
- [0234] 209 negative rounding
- [0235] 210 slotting
- [0236] 211 alternating plate thicknesses in the plate
- [0237] 212 U-profiling
- [0238] FIG. 29 double honeycomb plate as the support core
- [0239] 213 honeycomb plate 1
- [0240] 214 honeycomb plate 2
- [0241] 215 connection of the support core plates through fusing/gluing
- [0242] 216 thick cover layer
- [0243] 217 thin cover layer
- [0244] 218 upright structure
- [0245] FIG. 30 light scaffolding plate, top view of latticed molding of claw and round groove part
- [0246] 231 plate A
- [0247] 232 plate B
- [0248] 233 claw on U-profile
- [0249] 234 round groove on pipe
- [0250] 235 top cover layer
- [0251] 236 additional web, also deformed as top layer
- [0252] 237 edge terminus
- [0253] 238 U-profile
- [0254] 239 pipe transverse support
- [0255] FIG. 31 light scaffolding plate, top view of latticed engaging round groove
- [0256] 240 plate A
- [0257] 241 plate B
- [0258] 244 round groove resting on pipe
- [0259] 245 top cover layer
- [0260] 246 edge terminus with extension by additional profile
- [0261] 247 edge terminus
- [0262] 249 pipe transverse support

- [0263] FIG. 32 section through the material to be pressed before the pressing step
- [0264] with perforated metal sheet
  - [0265] 251 top perforated metal sheet having sinkholes
  - [0266] 252 support core made of thermoplastic material, such as honeycomb
  - [0267] 253 bottom perforated metal sheet of typical type
  - [0268] 254 hot and cold pressing plates, stationary or as a band
  - [0269] with simple metal sheet having primer (adhesion promoter)
  - [0270] 255 metal cover layer
  - [0271] 256 primer (adhesion promoter) applied during rolling procedure of the sheet
  - [0272] 257 thermoplastic support core
  - [0273] 258 primer (adhesion promoter) applied during rolling procedure of the sheet
  - [0274] 259 metal cover layer
- [0275] FIG. 33 section through the "light scaffolding plate", compressed only from perforated metal sheet and support core
- [0276] 260 top perforated metal plastic cover layer with sinkholes
  - [0277] 261 support core fused on top and/or bottom
  - [0278] 262 bottom perforated metal plastic plate having plastic layer over entire area
- [0279] FIG. 34 surface of the plate having sinkholes before the pressing
- [0280] 263 top perforated metal sheet
  - [0281] 264 sinkhole having edge depression
  - [0282] 265 for example, honeycomb plate as support core
  - [0283] 266 bottom perforated metal sheet
- [0284] FIG. 35 surfaces of the light scaffolding plate
- [0285] 267 smooth plate having plastic layer over entire area without structure
  - [0286] 268 structured plate having plastic layer over entire area
  - [0287] 269 sinkhole perforated plate having visible metal and plastic layers
- [0288] FIG. 36 different forms of the perforated metal sheet before/after the pressing step longitudinal section through the perforated metal sheet
- [0289] 311 depth of the depression upon perforation at depression depth
  - [0290] 312 visible surface of sheet
  - [0291] 313 perforation
  - [0292] 314 depth of the depression upon further hole sinking
  - [0293] 315 hole sinking
- [0294] FIG. 37 cross-section through the perforated metal sheet
- [0295] 321 depth of the depression upon perforation at depression depth
  - [0296] 322 visible surface of sheet
  - [0297] 323 perforation
  - [0298] 324 depth of the depression upon further hole sinking
  - [0299] 325 hole sinking
- [0300] FIG. 38 top view of perforated metal sheet with hole sinking and linear bead sinking
- [0301] 331 depth of the depression
  - [0302] 332 visible surface of sheet
  - [0303] 333 perforation
  - [0304] 334 hole sinking
- [0305] FIG. 39 top view of perforated metal sheet having linear depression and additional hole sinking
- [0306] 341 depth of the depression
  - [0307] 342 visible surface of sheet
  - [0308] 343 perforation
  - [0309] 344 hole sinking
  - [0310] 345 remaining depression depth
- [0311] FIG. 40 top view of perforated metal sheet having linear depression and hole sinking
- [0312] 351 depression depth
  - [0313] 352 visible surface of sheet
  - [0314] 353 perforation
  - [0315] 354 metal sheet at hole level
- [0316] FIG. 41 surfaces having contours alternately in the metal sheet or in the plastic
- [0317] 361 visible sheet strips
  - [0318] 362 visible plastic strips
  - [0319] 363 hole contours
  - [0320] 364 wave contours
  - [0321] 365 corner contours
  - [0322] 366 cube contours
- [0323] FIG. 42 front view of light scaffolding plate having lateral protection part and board with openings
- [0324] 371 suspension claw or groove
  - [0325] 372 covering surface upper edge
  - [0326] 373 lateral protection part
  - [0327] 374 groove
  - [0328] 375 board
  - [0329] 376 opening in board
  - [0330] 377 securing pin

- [0331] FIG. 43 light scaffolding plate having combined lateral protection part and plank, view from plate beginning
- [0332] 378 suspension claw or groove
  - [0333] 379 displacement guard
  - [0334] 380 downward bevel lateral part
  - [0335] 381 upward bevel lateral protection part and plank
  - [0336] 382 covering surface upper edge
- [0337] FIG. 44 light scaffolding plate having lateral protection part and placed plank, cross-section behind plate beginning
- [0338] 383 upward bevel lateral protection part
  - [0339] 384 board
  - [0340] 385 securing pin
- [0341] FIG. 45 top view of surface of perforated metal plate having slotted bridge perforations, with thermoplastic filling
- [0342] 391 linear, offset orientation of the slotted bridge perforations
  - [0343] 392 supporting sheet part
  - [0344] 393 slightly sunk thermoplastic filling, covering bridge
- [0345] FIG. 46 slotted bridge hole longitudinal section and cross-section, after hot pressing, filled up like enclosure with thermoplastic material
- [0346] 411 anchoring of the thermoplastic bonding material over and around the slotted bridge
  - [0347] 412 slotted bridge
  - [0348] 413 honeycomb support core
  - [0349] 414 thermal welded bond to upper honeycomb shoulder
- [0350] FIG. 47 bead-like cover sheet configuration, overturned
- [0351] 421 overturned depression
  - [0352] 422 upper edge of sheet
  - [0353] 423 bonding layer
  - [0354] 424 enclosure of the depression
- [0355] FIG. 48 bulge-like cover sheet configuration
- [0356] 431 bulge
  - [0357] 432 upper edge of metal sheet
  - [0358] 433 for example, open groove
  - [0359] 434 bonding layer
- [0360] FIG. 49 hook-like shoulders on the sheet
- [0361] 441 hook
  - [0362] 442 upper edge of sheet
  - [0363] 443 bonding layer
  - [0364] 444 enclosure of the hook
- [0365] FIG. 50 connection points of the lateral protection and lateral parts with elastic overlap which continues the cover layer and presses on the next plate
- [0366] 451 lateral protection part 1
  - [0367] 452 lateral protection part 2
  - [0368] 453 upper edge of placed lateral part above lateral protection part 1
  - [0369] 454 upper edge of placed lateral part above lateral protection part 2
  - [0370] 456 lateral part 3
  - [0371] 457 lateral part 4
  - [0372] 458 groove for inserting lateral part and lateral protection part elastic overlap pressing on the next plate, welded on the top layer of the lateral part to a lateral edge and on the bottom via the elastic edge engaging in the groove
  - [0373] 459 covered seams of lateral protection parts and lateral parts
- [0374] FIG. 51 glued support core
- [0375] 461 L-shaped, C-shaped, or U-shaped downward bevel of the metal cover layer
  - [0376] 462 support core made of thermoplastic honeycomb or foam having closed pores
  - [0377] 463 thermoplastic layer enclosing the support core
  - [0378] 464 adhesive layer between metal cover layer and support core
- [0379] FIG. 52 lateral protection system construction having overlaps to the surrounding scaffolding panels
- [0380] 471 scaffolding panel 471
  - [0381] 472 scaffolding panel 472
  - [0382] 473 scaffolding panel 473
  - [0383] 474 scaffolding panel 474
  - [0384] 475 scaffolding panel 475
  - [0385] 476 scaffolding panel 476
  - [0386] 477 scaffolding panel 477
  - [0387] 478 scaffolding panel 478
  - [0388] 479 scaffolding panel 479
  - [0389] 480 overlap of scaffolding panel 472 to 471
  - [0390] 481 overlap of scaffolding panel 472 to 476
  - [0391] 482 overlap of scaffolding panel 472 to corner of 475
  - [0392] 483 overlap of scaffolding panel 473 to 472, 477 and corner of 476 and etc.
- [0393] FIGS. 53+54 fiberglass layers
- [0394] 496 linear glass fibers laid next to one another, multiple layers oriented longitudinally in thermoplastic plate or film

[0395] 497 linear glass fibers laid next to one another in thermoplastic plate or film

[0396] 498 linear glass fibers placed next to one another, longitudinal and transverse layers

[0397] 499 linear glass fibers laid next to one another, multiple longitudinal and transverse layers one on top of another

What is claimed is:

1-101. (canceled)

102. A light scaffolding plate to be laid, inserted, fitted, riveted, screw, glued, welded, or attached in another way in a metal, preferably aluminum frame of a facade or rolling scaffold provided for this purpose or to be suspended directly in a scaffold, in various lengths and widths as a sandwich panel having an upper and lower layer and spacers, located between them, made of plastic and methods for its manufacture,

wherein the upper and lower layers comprise sinkhole perforated sheet metal and are molded, fitting with one or more of the known scaffold floor systems or scaffold systems, bonded or embedded in a formfitting way through multiple rivets molded from the plastic of the spacer or its cover layers connected thereto.

103. The light scaffolding plate made of the material composite according to claim 102, fiber-reinforced plastic composite,

wherein it has border or edge terminuses, molded-on lateral parts, intermediate webs, frame reinforcements, shelving and suspension fittings on the entire or interlocking parts of the width or length, also in known claw, hook, or rounded groove form to be hung in an angled profile, U-profile, or tubular profile, which are molded directly on or from, and also only or additionally has holes to be hung in the scaffold structure, which is provided with corresponding upright pins, the holes being reinforced by hollow rivets made of metal or plastic or by material compression at the hole edges.

104. The light scaffolding plate according to claim 102,

wherein it is suitable for a falling weight test, with or without reinforcement, frameless, self-supporting, supporting a full load, and using 100, 150, 200, or 250 kg falling weight in the middle or another location between the suspensions of the plate and is stackable with or without a molded lateral protection part of 10, 15, or even, as a falling guard, of over 100 cm height.

105. The light scaffolding plate according to claim 102,

wherein the lateral protection parts have identical or different thicknesses or recesses and/or openings, are transparent to light, are extended by independent second and/or third parts in height through placement, insertion, or other attachment and are fixed in such a way that they are removable and secured against unintentional detachment.

106. The light scaffolding plate according to claim 102,

wherein the support core between the two cover layers of the plate is made of molded thermoplastic or duroplastic material, such as honeycombs, webs, caps, corrugated profiles, foamed or other spacer shapes, particu-

larly having closed pores, with or without fiber, textile, or nonwoven material reinforcement or solid external and/or intermediate webs.

107. The light scaffolding plate according to claim 102,

wherein one or both cover layers, the boundary terminuses, and/or molded-on lateral parts, suspension and paneling fittings and/or the support core are exclusively made of multilayered thermoplastic material, prepared with highly-oriented reinforcement elements having bidirectional molecular alignment, of identical or similarly high rigidity in strength and do not contain glass fibers or other reinforcements made of non-thermoplastic material and are thus completely recyclable.

108. The light scaffolding plate according to claim 102,

wherein the thermoplastic support core and/or the cover layers or the material penetrating the perforated sheet on one or both sides are made of Plexiglas (PMMA), thermoplastic polyester (PET/G), polyamide (PA), polycarbonate (PC), polyethylene (PE), polytetrafluoroethylene (PTFE), polypropylene (PP), polyoxymethylene (POM), polyvinyl chloride (PVC) or a mixture of these substances having identical or different melting points or of a duroplastic or duromeric material such as phenol resin, cresol resin (PF), urea resin (UF), melamine resin (MF), and polyester resin (UP) or a mixture of these substances.

109. The light scaffolding plate according to claim 102,

wherein, to achieve better strength and rigidity, modulus of elasticity, modulus of bending and creep, hardness, dimensional stability in the heat, tearing and tensile strength, compression resistance, dimensional stability, density, fatigue strength, thermal conductivity, melting viscosity, reduction of stretching, impact toughness, impact strength when notched, creep tendency, shrinkage, thermal expansion, abrasion resistance, UV and weather resistance, and melt flow index, additives which influence these are admixed with the thermoplastic material or parts thereof, such as talcum, wood flour, wollastonite, zinc oxide, metal powder, mica, calcium carbonate, or other suitable substances, or the materials themselves already have different melting points.

110. The light scaffolding plate according to claim 102,

wherein it has a width of 58 to 65, 88 to 95, 118 to 125, or up to 150 cm, calculated with or without the lateral upward bevel, and a length of up to approximately 60, 100, 150, 200, 250, 300, 350, or 400 cm and may be attached sufficiently securely and removably to the scaffolding using securing pins or other securing devices.

111. The light scaffolding plate according to claim 102,

wherein the lateral downward bevel in the region of the suspension at both ends of the plate is used as a displacement guard against the suspension and the suspension is secured on one or both ends of the plate using a permanently elastic plastic spring or flap which only opens to pressure, the plate has a slip-proof, raised, or depressed texture over the entire top of the cover layer or at individual points thereof, the perforated metal sheet on top and below in connection with the support core makes 70, 60, or 50% in the actual perforation makes up approximately 50, 40, or 30%

with a sinking to 1 to 3 mm and thus absorbs the static strain towards sag at the required load.

**112.** The light scaffolding plate according to claim 102,

wherein the perforated metal is either aluminum, also admixed with other metals, steel (hot galvanized or aluminized), stainless sheet steel, or other metals or metal composite materials and has either a simple perforation, a sinkhole, slotted bridge, projecting, lapped, or similar perforation or a depressed perforation in this or similar form and is provided with stabilizing beads, which are oriented to the cover layer, in the longitudinal for transverse direction of the plate and is provided with an additional primer (adhesion promoter) or a color layer toward the top or bottom.

**113.** The light scaffolding plate according to claim 102,

wherein the external perforated sheet cover layer has unperforated metal strips between the rows of holes in the perforation, particularly in the longitudinal or similar perforation, in the direction of the main load towards sag and, in the event of sinkhole, slotted bridge, or similar perforations in the perforated sheet, which are positioned on one or both sides of the plate, preferably linearly parallel to the main sag direction upon load of the plate, and may even be offset to one another, the plastic material which penetrates the sheet at the hole locations has multiple connections, equal to the multiple holes, which are formfitting, similar to rivets or flat rivets, between the perforated sheet and support core, so that a homogeneous connection arises which is distributed over the entire plate area.

**114.** The light scaffolding plate according to claim 102,

wherein the perforated sheet cover layer is provided over the entire area on one side only on top and is provided with lateral C-shaped, L-shaped, or U-shaped stiffening downward bevels, which completely or partially enclose the support core on the other side.

**115.** The light scaffolding plate according to claim 102,

wherein it or the lateral projection parts which are molded or placed on has an identification or inscription, also as an advertising text, which is visible over the entire area and/or only through the holes of the perforated sheet cover layer, is colored permanently, weather resistant, and UV resistant in the plastic material in one or more colors by choice and/or in the metal cover layer, or is provided with a primer/adhesion promoter.

**116.** The light scaffolding plate according to claim 102,

wherein it has a small or large climb-through opening having an inserted flap made of identical material, which is connected to the plate either using typical hinges or preferably using a flexible cover and hinge layer made of permanently movable, thermoplastic material, and permanently actively closes the climb-through opening automatically or by actuating the closure after climbing through, the frame for hanging the flap of the climb-through opening containing reinforcements and the flap being made of the same material as the plate, either in the same or much lower thickness.

**117.** The light scaffolding plate according to claim 102,

wherein, through a deformation of the cover layers, these become supporting webs or profiles within or at the

edges of the support core or are used themselves as the support core, and within the plate or as a lateral terminus of the plate in the longitudinal direction, one or more pipes or U-profiles made of metal or fiberglass-reinforced plastic, also enclosed or molded out of perforated sheet metal, are welded in or on or glued in or on to absorb elevated loads or only as a boundary terminus.

**118.** The light scaffolding plate according to claim 102,

wherein the scaffolding plate cover continues with identical surface in one piece without interruption up to the end of the web of the claw or round groove of the suspension fitting or the two suspension fittings, the metallic scaffolding plate cover layer is embedded in the plastic cover layer at its edges as a protection from injuries and the web of the claw of the suspension part is positioned perpendicularly to the scaffolding plate or is positioned angled up to 45 degrees to the scaffolding plate or with a slight angle inward and the opening of the claw of the suspension part, up to its throat, has a depth of 10 and at most 20 mm, of 20 and at most 30 mm, of 30 and at most 48 mm, or a larger dimension.

**119.** The light scaffolding plate according to claim 102,

wherein the rounded area of the suspension groove is crescent-shaped or only partially crescent-shaped, the web of the claw of the suspension part simultaneously supports the holding of the plate on the rising web of the holder profile through appropriate deformation, and a component of the suspension part of the plate, both for the claw and for the suspension round groove, is a holding guard engaging on the holding profile or suspension pipe.

**120.** The light scaffolding plate according to claim 102,

wherein a perforated metal plate is embedded or welded bodily enclosed permanently in a thermoplastic layer, plate, or film made of one or more layers, in the perforated metal plate, all or only some holes of the plate have hole edge depressions, the perforated metal cover layer has a constriction of the hole tapering conically inward on all or only individual hole edges, and all or individual holes of the perforated metal cover layer simultaneously have edge depressions and the material of the cover layer narrows in thickness toward the hole center on all or individual hole edges.

**121.** The light scaffolding plate according to claim 102,

wherein the edge depressions of the perforated metal cover layer have the height, more than the height, or less than the height corresponding to the material thickness thereof, the edge of the holes in the perforated metal cover layer runs from top to bottom at an angle of 25 to 65 degrees toward the hole center and is or is not flattened shortly before the opening of the hole, and the height of the downward bevel may exceed the plate thickness by up to multiple times.

**122.** The light scaffolding plate according to claim 102,

wherein, from the viewpoint of the plate center, a groove is molded onto the entire plate width in front of the outer downward bevel(s), from the viewpoint of the plate center, a semicircular or partially semicircular recess is provided in front of the outer downward bevel(s) on both sides on thinner plates and continuously on thicker plates, and it is provided in the main

support direction with grooves, beads, and/or upward and downward bevels and, within the plate area, it has small or large recesses, with or without plates or inserted covers of the same or lesser thickness, also bonded to the plate using elastic thermoplastic material.

123. The light scaffolding plate according to claim 102,

wherein both the thermoplastic support core in direct connection and also the cover layers as intermediate layers of the welded connection to the perforated metal are manufactured from polypropylene (PP) and the plate is therefore completely recyclable in spite of the different melting points of plastic and metal.

124. The light scaffolding plate according to claim 102,

wherein all or individual holes of the perforated or sinkhole perforated sheet metal plate are implemented as round or square holes, oblong holes, hexagonal or polygonal holes, diamond holes, triangular holes, star-shaped holes, keyholes having rounded corners or angled, or even as other types of holes and the plate has an area weight of up to 11, 9, or 7 kg/m<sup>2</sup> at a thickness of approximately 50 to 60 mm, an area weight of up to 10, 8, or 6 kg/m<sup>2</sup> at a thickness of approximately 40 to 50 mm, an area weight of up to 7, 6, or 5 kg/m<sup>2</sup> at a thickness of approximately 20 to 30 mm, and an area weight of up to 6, 5, 4, 3.5, or 3 kg/m<sup>2</sup> at a thickness of up to 20 mm.

125. The light scaffolding plate according to claim 102,

wherein the perforated metal or sinkhole perforated sheet metal cover layers in an aluminum alloy, which are bonded to plastic, each weigh approximately 0.6 kg to 1.8 kg and are 0.3 to 0.5 mm thick, the thermoplastic support core, with or without reinforcement, weighs 0.6 to 1.0 kg/m<sup>2</sup> per centimeter of thickness, and the finished compressed plate having aluminum cover layer is chemically treated or anodized in a selected color in the anodizing bath in the cover layers together with the visible plastic parts.

126. A light plate analogous to a scaffolding plate according to claim 102,

wherein it is used as a floor plate, timbering plate, wall plate, wall panel, sound protection plate, thermal or sound insulation plate, roof panel, support layer for a photovoltaic laminate or for photovoltaic cells, table or table tennis plate, bench or chair, also having molded-on and foldable legs, door, gate, or garage door, stair step, as a decorative plate and for vehicle superstructures, as well as many other products, and molded as a supporting profile and it is used as a vacuum panel if a gas-permeable support core and a gas-impermeable film which encloses it are provided.

127. A method for manufacturing a light support plate according to claim 102 in a stationary plate press or double-band press,

wherein the plate is compressed from a thermoplastic support core, which determines the color of the outside of the plate, or other spacers in oversized thickness and required width and length in the middle, over which only a sheet, a perforated sheet, or a sinkhole perforated sheet is laid on the top and bottom, in a single hot press and cold press pass having temperatures for heating and cooling tailored to the different melting points of the

materials and the material thicknesses in direct contact with the hot and subsequently cold plates of the press and/or the possibly required, also textured separating film(s) and is thermoplastically bonded to the panel, whose later thickness and color design are previously determined, and receives the final, depressed or raised surface structure and shape and, if corresponding molding tools are used, additional molded-on parts such as claws, grooves, and other suspension fittings, closures, reinforcement, inserts and web inclusions, edges, and holes.

128. The method for manufacturing a light scaffolding plate according to claim 127,

wherein the plates are pressed in a single pressing pass laid next to or one behind another in multiple units and in which the liquid thermoplastic compound arising from the thermoplastic cover layer and/or the surface of the support core during the hot pressing flows through the holes, fills up the depressions in the plate, and, during the subsequent cooling, forms the solid rivets required for the bodily formfitting bond or the clawing.

129. The method for manufacturing a light scaffolding plate according to claim 127,

wherein, when a perforated metal plate is used, the liquid thermoplastic compound arising from the thermoplastic cover layer and/or the surface of the support core during the hot pressing flows through the holes and expands over the holes into a flat plastic layer and, during the subsequent cooling, forms the connection pins to the flat plastic layer required for a bodily formfitting bond or the clawing, the stability, the modulus of elasticity, and the UV and weather resistance of the plate, in addition to the strength and the material properties of the cover layer, being influenced by sinking the holes and/or through offset arrangement of the holes in the direction of the strain.

130. The method for manufacturing a light scaffolding plate according to claim 127,

wherein the method is performed in a continuously running extruding procedure with the honeycomb support core, with or without flattened plate surface, or a continuously running deep drawing procedure for a support core in a tubular, cap, box, web, corrugated, or similar structure, the introduction of slots in the honeycomb structure, with subsequent hot pressing of the cover layers of identical or different thickness from the coil or as a plate in the continuous or plate press clocked method, with or without the application of depressed or raised structures or surface coatings such as a slide protection structure or perforated metal or sinkhole perforated metal or similar layers, notching slots, holes, or similar things, the subsequent edging and fitting molding and the trimming or cutting while maintaining or introducing the required, exactly controlled melting temperature at the surfaces to be fused and material underneath to be melted and subsequent cooling in the subsequent cold press, each under electronic or manual control and precise consideration of the temperature window required for the material.