

Moyon & Lemercier,

Lasting Mach.

No. 101,151.

Patented Mar. 22. 1870.

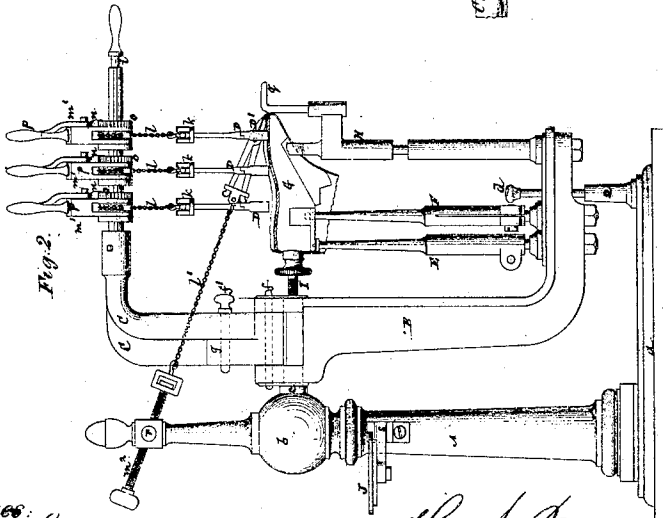
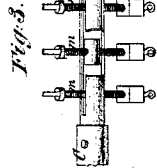
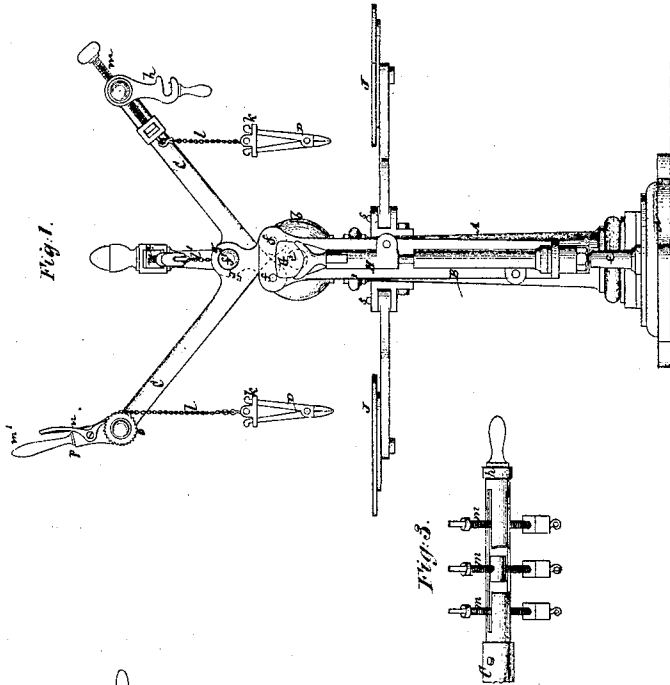

Witnesses:

Fred. Haynes
R. C. Rubenau

H. N. Moyon
J. C. Lemercier
per Emmanuel Attorneys

United States Patent Office.

HENRI NICOLAS MOYON AND JACQUES EUGENE LEMERCIER, OF PARIS,
FRANCE.

Letters Patent No. 101,151, dated March 22, 1870.

IMPROVED LASTING-MACHINE.

The Schedule referred to in these Letters Patent and making part of the same.

To all whom it may concern:

Be it known that we, HENRI NICOLAS MOYON and JACQUES EUGENE LEMERCIER, of Paris, in the Empire of France, have invented certain new and useful Improvements in Apparatus for the Manufacture of Boots and Shoes, of which the following is a full, clear, and exact description, reference being had to the accompanying drawing forming part of this specification, and in which—

Figures 1 and 2 represent front and side views of said apparatus with the working parts in different positions.

Figure 3 is a top view of one of the crane arms with its pincers and adjusting-screws.

Similar letters of reference indicate corresponding parts.

The object of the invention is to facilitate the manufacture of boots and shoes, to which end the improvements embrace two crane-like arms working on independent centers, and each carrying a series of pincers designed to act on each side of the upper leather to draw it over the sole, which is on the last; also a pincers arrangement for drawing and stretching the toe part of the upper over the sole, the several pincers being suspended by chains, and made capable of a drawing as well as a closing action, and the machine having connected with its frame horizontally-swinging tables for tools, brads, or nails used in securing the upper to the sole.

In the accompanying drawing—

A is a column or support, the base of which is secured by bolts to a bed-plate, *a*. This column is formed with a ball or projection, *b*, that carries a forwardly-projecting stationary shaft or arm, *c*, for a downwardly-disposed crane or arm, B, to swing or turn on when required, but which is held stationary in a vertical position by a removable pin, *d*, arranged to pass through the horizontal portion of the arm B into a socket-piece, *e*, attached to the bed.

Horizontally pivoted, as at *f, f*, to the upper portion of this crane-like arm B are upper cranes C C, which may either be lowered and extended, as represented in fig. 1, and when in such position be locked by a pin, *f'*, made to pass through ears *g, g*, or be raised and closed into moderate proximity with each other as regards their forwardly-projecting horizontal arms, which is the position represented for them in fig. 2, and when they are locked by a catch-lever, *h*, on the horizontal arm of the one crane, made to drop onto or over a reduced portion, *i*, of the horizontal arm of the other crane.

D D are two sets or a right and left-hand series of pincers, carried in a pendent manner by the horizontal

arms of the cranes C C with freedom of adjustment, both as regards their being raised and lowered, and of traveling backward or forward along said arms. To this end said pincers D D may be fitted with slides *k, k*, which, on being worked up or down along the handles of the pincers, serve to open and close the latter, and which serve for their suspension by chains *l, l* to the devices for raising and lowering the pincers, and for allowing of their adjustment along the cranes. These devices may either be screws *m*, carrying swivels, to which the chains are attached, and working through boxes fitted to slide longitudinally within the horizontal bars of the cranes, or they may be longitudinally sliding ratchet contrivances *m'*, arranged upon the horizontal bar of the crane, and, in addition to being freely adjustable along the same, being capable of raising or lowering the pincers on releasing-pawls *u*, that bite into the ratchets *o*, and suitably turning, accordingly as it is required to raise or lower the pincers, pulley-levers *p* forming part of such ratchet-contrivances and connected by the chains *l* with the pincers.

Mounted in a vertically-adjustable manner on studs fastened to the horizontal arm of the crane-piece B, as for instance, by means of split sockets, are two vertical rods, E and F, the one E of which serves to support the last G below the heel, while the other rod F enters and steadies the last in advance of the heel. There is also a vertically-adjustable support, H, carrying at its top a clip to receive the more forward portion of the last. This support or rather the stud which carries it, should be adjustable by a slotted connection or otherwise, along the horizontal arm or base of the crane-piece B. Said support H also carries a hooked clamp, *q*, for holding down the upper on the sole in front when required during the operation, but which is capable of being turned out of the way, as represented in fig. 2, and of being independently raised or lowered, as required.

By removing the pin *d*, and suitably swiveling the cranes C C and crane-piece B, facility is afforded for examining and ascertaining if the upper leather perfectly fits the last.

The pincers D D serve to pinch or hold the edges of the sides of the upper, and being adjustable vertically and horizontally, as described, afford every convenience as regards their adaptability to the work, and operated as described, exert a drawing as well as a squeezing pressure on the leather. The upper portion of the column A has connected with it similarly-constructed pincers, D', secured by a chain, *l'*, to a screw, *m'*, which works through a box arranged to swivel on a center, as at *r*, in the column. Such pin-

cers D' has an oblique traverse or action, and serves by its arrangement or the disposition of its traction-screw to stretch the end of the boot or shoe upper.

I is an adjustable screw support to the back of the heel of the last, and

J J are horizontally swinging tables pivoted, as at s, to the column A, and serving to hold brads, nails, tools, or other articles used in making the boot or shoe. When swung toward each other, they approach the last, and thus stand in a convenient position for the work, but they may be swung back or to one side when it is desirable they should be out of the way.

The upper being placed on the last G so that its edges extend beyond or above the sole lying on the inverted last, and the cranes C C being closed and locked, and the pincers D D brought in proper position to take hold of the side edges of the upper, the screws *m* or ratchet devices *m*¹ are operated, so as to cause said pincers to draw on and stretch the leather.

The pincers D' are similarly adjusted and operated to draw and stretch the end of the upper, and which is usually a most difficult portion to stretch and a most important part to be properly stretched.

To facilitate the draft of the pincers D' over the inner sole, which lies on the inverted last, a metal plate may be laid on said sole for the pincers to rest on and travel over. When the end of the upper has been suitably stretched, it is secured by nails or brads, and the screw *m*² relaxed to release the pincers.

Generally it will be found preferable to stretch the end of the upper first. During such operation, the cranes C C are lowered or opened, as in fig. 1, and when the drawing of the end is finished, the same secured and pincers D', removed, the cranes C C are raised and closed, and the pincers D D made fast to the upper, and power applied to the screws *m* or ratchet devices *m*¹, to give the required tension to the side edges of the upper; the cranes C C are then swung to bring the edges of the upper, onto or over the edges of the sole to which it is fixed by means of brads.

As the part corresponding with the heel often presents difficulties to its being well fitted, there is placed between this part of the last and the upper a piece of leather, which takes the place of a shoeing horn or forms a guard-piece. This leather is provided with a metal eyelet, for the insertion of a suitable tool to raise the heel-piece, and consequently to draw that part of the upper corresponding with the heel into position to be secured.

Straps or cords may be substituted for the chains 17.

As the taking up and placing in position of the brads requires considerable care and time, we design to use for such purpose a small hand tool, consisting of a magnet placed within a tube acted upon by a spring within the handle of the tool, to attract and hold the brad, which by a slight blow on the head of the tool, may afterward be detached over the place it is required.

What is here claimed, and desired to be secured by Letters Patent, is—

1. The combination of the swinging lower crane or bent arm B with the crane C C and last-supports E, F, and H, substantially as specified.

2. The combination of the pincers D D, constructed and arranged for operation as described; with the swinging cranes C C, from which they are suspended, and made capable of adjustment relatively to the last, essentially as and for the purpose herein set forth.

3. The pincers D', constructed and arranged for operation in relation to the last G, substantially as shown and described.

In testimony whereof we have hereunto set our names in presence of two subscribing witnesses.

MOYON.
EGNE. LEMERCIER.

Witnesses:

A. LE BLANC.
J. U. ZUST.