

(19)



(11)

EP 3 757 679 B1

(12)

EUROPEAN PATENT SPECIFICATION

(45) Date of publication and mention of the grant of the patent:
19.03.2025 Bulletin 2025/12

(51) International Patent Classification (IPC):
G03G 15/20 (2006.01) G03G 15/00 (2006.01)

(21) Application number: **20177951.9**

(52) Cooperative Patent Classification (CPC):
G03G 15/2053; G03G 15/2039; G03G 15/5004; G03G 2215/2035

(22) Date of filing: **03.06.2020**

(54) **HEATING DEVICE, FIXING DEVICE, AND IMAGE FORMING APPARATUS**

HEIZVORRICHTUNG, FIXIERVORRICHTUNG UND BILDERZEUGUNGSVORRICHTUNG

DISPOSITIF DE CHAUFFAGE, DISPOSITIF DE FIXATION ET APPAREIL DE FORMATION D'IMAGES

(84) Designated Contracting States:
AL AT BE BG CH CY CZ DE DK EE ES FI FR GB GR HR HU IE IS IT LI LT LU LV MC MK MT NL NO PL PT RO RS SE SI SK SM TR

(72) Inventor: **SUGIYAMA, Ryohei**
Tokyo, Ohta-ku 143-8555 (JP)

(30) Priority: **24.06.2019 JP 2019116780**
19.03.2020 JP 2020048747

(74) Representative: **Marks & Clerk LLP**
15 Fetter Lane
London EC4A 1BW (GB)

(43) Date of publication of application:
30.12.2020 Bulletin 2020/53

(56) References cited:
EP-A2- 1 995 646 JP-A- 2004 191 966
JP-A- 2006 251 479 JP-A- 2016 024 422
US-A1- 2014 294 417

(73) Proprietor: **Ricoh Company, Ltd.**
Tokyo 143-8555 (JP)

EP 3 757 679 B1

Note: Within nine months of the publication of the mention of the grant of the European patent in the European Patent Bulletin, any person may give notice to the European Patent Office of opposition to that patent, in accordance with the Implementing Regulations. Notice of opposition shall not be deemed to have been filed until the opposition fee has been paid. (Art. 99(1) European Patent Convention).

Description

BACKGROUND

Technical Field

[0001] Embodiments of the present disclosure generally relate to a heating device, a fixing device, and an image forming apparatus.

Description of the Related Art

[0002] As a fixing device used in an electrophotographic image forming apparatus, for example, JP-6164014-B (JP-2015-069094-A) discloses the fixing device including a fixing belt as a fixing member, a nip formation member to form a fixing nip, and a heater that is disposed inside a loop of the fixing belt and radiates radiant heat to heat the fixing belt and the nip formation member. The fixing device including the heater disposed inside the loop of the fixing belt adopts a reflector structure including a reflector having high reflectance and covering around the heater to reflect infrared rays that are not directly emitted from the heater to an object to be heated and irradiate the object to be heated with all infrared rays radially radiated from the heater.

[0003] However, such a reflector structure has problems, a poor control performance for a target temperature and a fixing failure caused by a temperature drop in the fixing nip because the temperature of the nip formation member changes the amount of heat supplied to the fixing belt in the fixing nip.

[0004] US 2014/0294417 A1 discloses an image forming apparatus including an endless belt, a heater, a first temperature sensor, a second temperature sensor, and a controller.

[0005] JP201602442A discloses a fixation device comprising a fixation belt; a pressure roller; belt guide members; halogen heaters; and a reflection member disposed between the halogen heaters and the belt guide members that reflects heat from the halogen heaters to heat the fixation belt.

[0006] JP2004191966 discloses a fixing device that predicts maximum power supply to a fixing heater according to rise time of temperature sensed by a main thermistor or a sub-thermistor, and corrects output power according to the maximum power supply at the time of output of power necessary for stable operation of the fixing device.

[0007] JP2006251479A discloses a fixing device in which temperature control on the surface of a heating member is accurately performed.

[0008] EP 1 995 646 A2 discloses a fixing device to fix an image to a print medium, including: a pressing roller, which is driven to rotate; a heat transferring unit facing the pressing roller, and contacting the pressing roller at a fixing nip position, to heat to a print medium disposed at the fixing nip position; a heating member that presses an

portion of the heat transferring unit against the pressing roller at the fixing nip position; and a heat source that heats a preheating position of the heat transferring unit, and heats the heating member.

5

SUMMARY

[0009] The object of the present disclosure is improving the temperature control performance of a rotating member such as a fixing belt and preventing a fixing failure caused by a temperature drop in a fixing nip. In order to achieve the object, there is provided a heating device according to claim 1. Advantageous embodiments are defined by the dependent claims.

[0010] Advantageously, the heating device includes a rotating member having an endless form, a heater disposed inside a loop of the rotating member, a pressing member disposed opposite the rotating member, a nip formation member, a first temperature sensor, and a second temperature sensor. The nip formation member contacts an inner circumferential surface of the rotating member to form a nip between the pressing member and the rotating member. The first temperature sensor is configured to detect a temperature of the nip formation member, and the second temperature sensor is configured to detect a temperature of the rotating member.

[0011] According to the present disclosure, the temperature control performance of a rotating member is improved, and a fixing failure caused by a temperature drop in the nip is prevented.

30

BRIEF DESCRIPTION OF THE DRAWINGS

[0012] The aforementioned and other aspects, features, and advantages of the present disclosure would be better understood by reference to the following detailed description when considered in connection with the accompanying drawings, wherein:

35

FIG. 1 is a schematic view of an image forming apparatus according to an embodiment of the present disclosure;

40

FIG. 2A is a schematic sectional view of a fixing device;

45

FIG. 2B is a schematic front view of the fixing device;

50

FIG. 3 is a schematic perspective view of the fixing device;

55

FIG. 4 is a schematic diagram illustrating the fixing device and a controller;

FIGS. 5A and 5B are graphs each illustrating a change of a fixing belt temperature and a change of a temperature of a nip formation member under conventional control; and

55

FIG. 5C is a graph illustrating a change of the fixing belt temperature and a change of the temperature of the nip formation member under control of the present embodiment.

[0013] The accompanying drawings are intended to depict embodiments of the present disclosure and should not be interpreted to limit the scope thereof. The accompanying drawings are not to be considered as drawn to scale unless explicitly noted.

DETAILED DESCRIPTION

[0014] In describing embodiments illustrated in the drawings, specific terminology is employed for the sake of clarity. However, the disclosure of this specification is not intended to be limited to the specific terminology so selected and it is to be understood that each specific element includes all technical equivalents that have a similar function, operate in a similar manner, and achieve a similar result.

[0015] Although the embodiments are described with technical limitations with reference to the attached drawings, such description is not intended to limit the scope of the disclosure and all of the components or elements described in the embodiments of this disclosure are not necessarily indispensable.

[0016] With reference to drawings, a description is given of a fixing device according to an embodiment of the present disclosure and an image forming apparatus such as a laser printer using the fixing device. The laser printer is just an example of the image forming apparatus, and thus the image forming apparatus is not limited to the laser printer. That is, the image forming apparatus can be a copier, a facsimile machine, a printer, a plotter, and a multifunction peripheral having at least two of copying, printing, facsimile transmission, plotting, and scanning capabilities; or an inkjet recording apparatus.

[0017] It is to be understood that identical or similar reference characters are given to identical or corresponding parts throughout the drawings, and redundant descriptions are omitted or simplified below. The dimensions, material, shape, and relative position in a description for each constituent component are examples. Unless otherwise specifically described, the scope of the present disclosure is not limited to those.

[0018] Although a "sheet medium" as a recording medium is described as a "sheet" in the following embodiments, the "sheet medium" is not limited to the sheet made of paper. Examples of the "sheet" include not only the sheet but also an overhead projector (OHP) transparency, a fabric, a metallic sheet, a plastic film, and a prepreg sheet including carbon fibers previously impregnated with resin.

[0019] Examples of the "sheet medium" include all media to which developer or ink can adhere, and so-called recording paper and recording sheets. Examples of the "sheet" include thick paper, a postcard, an envel-

ope, thin paper, coated paper (e.g., coat paper and art paper), and tracing paper, in addition to plain paper.

[0020] The term "image forming" used in the following description means not only giving an image having a meaning, such as a character or a figure, to a medium but also giving an arbitrary image having no meaning, such as a pattern, to a medium.

[0021] A configuration of the image forming apparatus according to an embodiment is described below.

[0022] FIG. 1 is a schematic view of a laser printer as an example of an image forming apparatus 100 including a fixing device 300 according to an embodiment of the present disclosure. The image forming apparatus 100 includes an image bearer 2 such as a photoconductor drum and a photoconductor cleaner 3. The image forming apparatus 100 further includes a charging device 4 as a charger that uniformly charges the surface of the image bearer, a developing device 5 that renders visible an electrostatic latent image on the image bearer, a transfer device TM disposed under the image bearer 2, a discharger, and the like.

[0023] An exposure device 7 as an image forming device is disposed above the image bearer 2. The exposure device 7 performs writing and scanning based on image data, that is to say, irradiates the image bearer 2 with laser light Lb emitted by a laser diode based on image data and reflected by a mirror 7a to form an electrostatic latent image on the image bearer 2.

[0024] A sheet feeder 50 including a tray loaded with sheets P is disposed in a lower portion of the image forming apparatus 100. The sheet feeder 50 is configured as a recording-medium supply device and can house a sheaf of many sheets P as recording media. The sheet feeder 50 is configured as one unit together with a sheet feeding roller 60 as a conveyor for the sheets P.

[0025] Downstream from the sheet feeding roller 60 in a sheet conveyance direction, a registration roller pair 250 as a separation and conveyance means is disposed. The registration roller pair 250 temporarily stops the sheet P fed from the sheet feeder 50. Temporarily stopping the sheet P causes slack on the leading-edge side of the sheet P and corrects a skew of the sheet P.

[0026] The registration roller pair 250 sends the sheet P that contacts the registration roller pair 250 and has the slack on the leading-edge side of the sheet P toward a transfer nip N of the transfer device TM at a timing to suitably transfer a toner image on the image bearer 2 onto the sheet P. A bias applied at the transfer nip N electrostatically transfers the toner image formed on the image bearer 2 onto the sheet P at a desired transfer position.

[0027] The fixing device 300 is disposed downstream from the transfer nip N in the sheet conveyance direction. The fixing device 300 includes a fixing belt 310 as a rotating member, a halogen heater 361 as a heater inside a loop of the fixing belt 310, which is described later, and a pressure roller 320 as a pressing member that rotates while contacting the fixing belt 310 at a predetermined

pressure.

[0028] Next, operations of the image forming apparatus 100 according to the present embodiment are described below.

[0029] The sheet feeding roller 60 rotates in response to a sheet feeding signal from a controller of the image forming apparatus 100. The sheet feeding roller 60 rotates to separate the uppermost sheet from a sheaf of sheets P loaded in the sheet feeder 50 and send the uppermost sheet out to a sheet feeding path.

[0030] When the leading edge of the sheet P sent by the sheet feeding roller 60 reaches a nip of the registration roller pair 250, the sheet P forms slack and temporarily stops. The registration roller pair 250 corrects the front-end skew of the sheet P and rotates in synchronization with an optimum timing to transfer a toner image on the image bearer 2 onto the sheet P.

[0031] The charging device 4 uniformly charges the surface of the image bearer 2 to high potential. The exposure device 7 irradiates the surface of the image bearer 2 with the laser light Lb based on the image data and reflected by the mirror 7a.

[0032] The surface of the image bearer 2 irradiated with the laser light Lb has the electrostatic latent image due to a drop in the potential of the irradiated portion. The developing device 5 includes a developer bearer 5a bearing a developer including toner and transfers unused black toner supplied from a toner bottle to the surface portion of the image bearer 2 having the electrostatic latent image, through the developer bearer 5a.

[0033] The image bearer 2 to which the toner has been transferred forms (develops) a toner image on the surface of the image bearer 2. The transfer device TM transfers the toner image formed on the image bearer 2 onto the sheet P.

[0034] A cleaning blade 3a in the photoconductor cleaner 3 removes the residual toner adhering to the surface of the image bearer 2 after a transfer process. The removed residual toner is collected to a waste toner container.

[0035] The sheet P bearing the toner image is conveyed to the fixing device 300. The sheet P conveyed to the fixing device 300 is sandwiched by the fixing belt 310 and the pressure roller 320. Then, heating and pressing fixes the unfixed toner image onto the sheet P. The sheet P fixed the toner image is sent out from the fixing device 300.

[0036] Next, a description is given of the fixing device 300 according to the present embodiment of the present disclosure.

[0037] The fixing device 300 is an embodiment of a heating device according to the present disclosure. In addition to the fixing device, the heating device according to the present disclosure is also applicable to a dryer to dry ink applied to the sheet in an inkjet type image forming apparatus and a coating device (a laminator) that heats, under pressure, a film serving as a covering member onto the surface of the sheet such as paper conveyed by a belt.

[0038] As illustrated in FIGS. 2A, 2B, and 3, the fixing device 300 includes a thin fixing belt 310 having a low thermal capacity and a pressure roller 320. In addition, the fixing device 300 includes a first temperature sensor 381 as a first temperature detector, a second temperature sensor 382 as a second temperature detector, and a third temperature sensor 383 as a third temperature detector, as described in detail later. The first temperature sensor 381 detects a temperature TN of a nip formation member, the second temperature sensor 382 detects a temperature of the fixing belt 310 inside a range of a sheet conveyance span in the longitudinal direction of the fixing belt 310, and the third temperature sensor 383 detects a temperature of the fixing belt 310 outside the range of the sheet conveyance span, that is a non-sheet conveyance span in the longitudinal direction of the fixing belt 310.

[0039] The fixing belt 310 includes, for example, a tubular base made of polyimide (PI), the tubular base having an outer diameter of 25 mm and a thickness of from 40 to 120 μm . The fixing belt 310 further includes a release layer serving as an outermost surface layer. The release layer is made of fluoro-resin, such as tetrafluoroethylene-perfluoroalkylvinylether copolymer (PFA) and polytetrafluoroethylene (PTFE), and has a thickness of from 5 μm to 50 μm to enhance durability of the fixing belt 310 and facilitate separation of the sheet P from the fixing belt 310. An elastic layer made of rubber having a thickness of from 50 to 500 μm may be provided between the base and the release layer.

[0040] The base of the fixing belt 310 may be made of heat-resistant resin such as polyetheretherketone (PEEK) or metal such as nickel (Ni) or stainless steel (Stainless Used Steel, SUS), instead of polyimide. The inner circumferential surface of the fixing belt 310 may be coated with polyimide or polytetrafluoroethylene (PTFE) as a slide layer.

[0041] The pressure roller 320 having, for example, an outer diameter of 25 mm, includes a solid iron cored bar 321, an elastic layer 322 on the surface of the cored bar 321, and a release layer 323 formed on the outside of the elastic layer 322. The elastic layer 322 is made of silicone rubber and has a thickness of 3.5 mm, for example.

[0042] Preferably, the release layer 323 is formed by a fluoro-resin layer having, for example, a thickness of approximately 40 μm on the surface of the elastic layer 322 to improve releasability. The pressure roller 320 is pressed against the fixing belt 310 by a biasing member.

[0043] Next, stays 330 and the nip formation member 380 are described below.

[0044] The stays 330 as support members and the nip formation member 380 extend axially inside the loop of the fixing belt 310. The stays 330 are a pair of metallic members that are made of stainless steel or the like, extend in parallel, face each other, and each have an I-shaped cross-section. Both side plates of the fixing device 300 support both end portions of the stays 330. The pair of stays 330 reliably receive the pressing force of the

pressure roller 320 acting on the nip formation member 380 and stably form a nip SN having a uniform width over an axial direction of the pressure roller 320 that is a longitudinal direction of the pressure roller 320. A plurality of types of sheets having different widths in the axial direction of the fixing belt 310 can pass through the nip SN. A stay as a support member may be one unit formed by connecting end portions of the pair of metallic members.

[0045] The nip formation member 380 is a plate bridged between the pair of stays 330 and supported by the stays 330. Both end portions of the nip formation member 380 in the sheet conveyance direction are each bent in an L shape, and the L-shaped bent portions 380a and 380b are located upstream and downstream in the sheet conveyance direction with respect to the pair of stays 330.

[0046] In FIG. 2A, the bent portion located upstream in the sheet conveyance direction is the bent portion 380b on the right side in FIG. 2A, and the bent portion located downstream in the sheet conveyance direction is the bent portion 380a on the left side in FIG. 2A. The first temperature sensor 381, which is described later, is sandwiched between the bent portion 380a located downstream in the sheet conveyance direction and the lower end portion of the stay 330.

[0047] The nip formation member 380 transfers heat in an axial direction that is a lateral direction in FIG. 2B in a short time to uniformize temperature of the fixing belt 310 in a width direction of the fixing belt 310. The nip formation member 380 is made of a thin plate having high thermal conductivity such as copper (398 W/mK), aluminum (236 W/mK) or silver to smoothly transfer the heat in the width direction. In consideration of cost, processing, and the like, the nip formation member 380 is preferably made of a thin copper plate.

[0048] The inner circumferential surface of the fixing belt 310 slides over the bottom surface of the nip formation member 380 that is a nip formation surface. In order to improve the abrasion resistance and the slidability of the nip formation surface, the nip formation surface may be treated with alumite or coated with fluororesin material. Additionally, a lubricant such as fluorine grease may be applied to the nip formation surface to ensure slidability over time.

[0049] In FIGS. 2A and 2B, the nip formation surface of the nip formation member 380 is planar. Alternatively, the nip formation surface may define a recess or other shape. For example, a recessed nip formation surface directs a leading edge of the sheet P toward the pressure roller 320 as the sheet is ejected from the fixing nip SN, thereby facilitating separation of the sheet P from the fixing belt 310 and preventing a sheet jam.

[0050] A separator may be disposed downstream from the fixing device 300 in the sheet conveyance direction to separate the sheet P from the fixing belt 310. In addition, a pressurization assembly may be disposed to press the pressure roller 320 against the fixing belt 310 and release

pressure exerted by the pressure roller 320 to the fixing belt 310.

[0051] Next, reflectors 370 and the halogen heater 361 in the present embodiment are described.

5 **[0052]** As illustrated in FIGS. 2A and 3, each reflector 370 is assembled to each of facing surfaces of the pair of stays 330. The halogen heater 361 as the heater is arranged at a center position between the right reflector 370 and the left reflector 370 and extends in the axial direction of the fixing belt 310.

10 **[0053]** Each of the reflectors 370 is made of a stainless steel plate or the like. Both end portions of the reflector 370, that is, an upper end portion 370a and a lower end portion 370b are bent toward outside and engaged with an upper end portion and a lower end portion of each of the pair of stays 330. The reflector 370 is configured to increase heating efficiency for the fixing belt 310 and the nip formation member 380 and to reduce wasteful energy consumption caused by heating the stay 330 with radiant heat from the halogen heater 361.

20 **[0054]** The surface of the reflector 370 facing the halogen heater 361 is treated with mirror finish or the like to increase reflectance. In the present embodiment, reflectance is measured using the spectrophotometer that is the ultraviolet visible infrared spectrophotometer UH4150 manufactured by Hitachi High-Tech Science Corporation in which the incident angle is set 5°.

25 **[0055]** In general, the color temperature of the halogen heater varies depending on the application. The color temperature of the heater for the fixing device is about 2500 K. The reflectance of the reflector 370 used in the present embodiment is preferably 70% or more with wavelengths of high emission intensity in the halogen heater 361, that is, specifically the wavelengths of 900 to 1600 nm and more preferably 70% or more with the wavelengths of 1000 to 1300 nm. Alternatively, instead of the reflector 370, a heater-side face of the stay 330 disposed opposite the halogen heater 361 may be insulated or given a mirror finish to obtain the same effects. In this case, the reflectance of the stay 330 subjected to the mirror finishing is preferably similar to the reflectance of the reflector 370.

30 **[0056]** Both side plates of the fixing device 300 support both ends of the halogen heater 361. The above-described fixing device 300 uses one halogen heater 361. Alternatively, the fixing device may use a plurality of halogen heaters 361 that are arranged in parallel and have different light emitting sections corresponding to a number of widths of sheets passing through the nip SN. Selecting the plurality of halogen heaters 361 in accordance with the width of the sheet and turning on the selected halogen heater 361 can effectively prevent overheating the non-sheet conveyance span of the fixing belt 310.

35 **[0057]** A center portion of the reflector 370 in a vertical direction is away from one of the pair of stays 330 and bulges inwardly in a curved convex shape toward the halogen heater 361. This curved inward convex surface

of the reflector 370 reflects infrared rays radiated in the left-right direction from the halogen heater 361 upward. A radiant light receiving surface of the fixing belt 310 is irradiated with the infrared rays reflected upward by the reflector 370.

[0058] The radiant light receiving surface of the fixing belt 310 located above the halogen heater 361 is directly irradiated with the infrared rays radiated upward from the halogen heater 361. In the present embodiment, infrared rays are mainly described as radiant light, but all light emitted from the halogen heater 361 as a heater is equivalent to radiant light.

[0059] On the other hand, the inner surface of the nip formation member 380 located under the halogen heater 361 is directly irradiated with the infrared rays radiated downward from the halogen heater 361. Additionally, the reflector 370 reflects infrared rays radiated in the left-right direction and an oblique downward direction from the halogen heater 361 toward the oblique downward direction. The reflector 370 irradiates the inner surface of the nip formation member 380 with the infrared rays reflected toward the oblique downward direction.

[0060] As described above, an upper portion of the fixing belt 310 and the nip formation member 380 under the halogen heater 361 are directly irradiated with the infrared rays radiated around the halogen heater 361. Additionally, the fixing belt 310 and the nip formation member 380 are also efficiently irradiated with the infrared rays reflected by the reflector 370, and the fixing belt 310 at the nip SN is efficiently heated to a target temperature T_c .

[0061] Next, operations of the fixing device 300 are described.

[0062] In FIG. 2A, when the sheet P is conveyed in a direction indicated by a horizontal arrow and passes through the nip SN, the sheet P is heated between the fixing belt 310 and the pressure roller 320 so that the toner image is fixed to the sheet P. At this time, the radiant heat from the halogen heater 361 heats the fixing belt 310 through the nip formation member 380.

[0063] The reflector 370 and the stay 330 in the present embodiment open toward the nip formation member 380. The above-described configuration can give a first heat transfer path and a second heat transfer path. In the first heat transfer path, the halogen heater 361 directly irradiates the nip formation member 380 with the radiant light and indirectly heats the fixing belt 310 via the nip formation member 380. In the second heat transfer path, the halogen heater 361 directly irradiates and heats the fixing belt 310 with the radiant light.

[0064] A structure of a conventional reflector around the halogen heater is generally an inverted U-shaped reflector structure that covers upper portion of the halogen heater. In contrast, in the present embodiment, as described above, the upper portion of the halogen heater 361 is opened, and each of the fixing belt 310 and the nip formation member 380 is irradiated with the infrared rays radiated from the halogen heater 361 and the infrared

rays reflected by the left and right reflectors 370.

[0065] A configuration of the present embodiment as illustrated in FIG. 2A including the nip formation member 380 and the fixing belt 310 which are separately irradiated with the infrared rays and a controller 400 which controls temperatures of the nip formation member 380 and the fixing belt 310 based on values detected by the first temperature sensor 381 and the second temperature sensor 382 has a better performance of temperature control about the fixing belt 310 and more advantageous in reduction of wasteful power consumption, which is described below, than a conventional configuration in which the halogen heater 361 concentratively irradiates the nip formation member with the infrared rays of the halogen heater 361.

[0066] Since the radiant light reflected by the reflector 370 is less likely to be absorbed again by the sealing body glass of the halogen heater, the present embodiment can give an advantage, that is, improvement of the heat transfer efficiency with respect to the fixing belt 310 and the nip formation member 380. Additionally, the controller 400 described below improves the performance of the temperature control of the fixing belt 310 and reduces the fixing failure due to the temperature drop in the nip and unnecessary power consumption.

[0067] Next, the temperature Sensors are described.

[0068] Values detected by the three temperature sensors 381 to 383 described above are input to the controller 400 in FIG. 4. The controller 400 controls an amount of alternating current (AC) power supplied to the halogen heater 361 by, for example, phase control. The controller 400 is arranged outside the fixing device 300 which is one embodiment of the heating device, for example, inside the controller of the image forming apparatus 100. The controller 400 may also configured as a dedicated product of the fixing device 300 independent of the controller of the image forming apparatus 100.

[0069] The first temperature sensor 381 detects a temperature T_N of the nip formation member 380. A compression coil spring or the like fixed to the stay 330 on the outlet side of the nip SN presses the first temperature sensor 381 against the inner surface of the bent portion 380a on the outlet side of the nip formation member 380 with a constant pressure. A contact position between the first temperature sensor 381 and the nip formation member 380 is disposed outside the nip SN and downstream from the nip SN in the sheet conveyance direction.

[0070] The second temperature sensor 382 is arranged upstream from the radiant light receiving surface in the rotation direction of the fixing belt 310 to face the outer circumferential surface of the fixing belt 310. That is, the second temperature sensor 382 is arranged to face the halogen heater 361 via the stay 330 and the reflector 370 and detect the temperature of the outer circumferential surface or the inner circumferential surface of the fixing belt 310, that is, a fixing belt temperature T_B . Both the first temperature sensor 381 and the second tem-

perature sensor 382 are disposed at the substantially center position in the axial direction (longitudinal direction) of the fixing belt 310 in the present embodiment but may be disposed in a range corresponding to a sheet conveyance span of the sheet having the smallest width in the axial direction of the fixing belt 310 and downstream from the nip SN in the rotation direction of the fixing belt 310.

[0071] The second temperature sensor 382 is disposed opposite the outer circumferential surface of the fixing belt 310 and downstream from the first temperature sensor 381 in the rotation direction of the fixing belt 310. Both the first temperature sensor 381 and the second temperature sensor 382 are disposed such that a position at which the first temperature sensor 381 detects the temperature of the nip formation member 380 and a position at which the second temperature sensor 382 detects the fixing belt temperature are close to each other in the circumferential direction of the fixing belt 310.

[0072] Next, the controller 400 is described.

[0073] The controller 400 in FIG. 4 controls power supplied to the halogen heater 361 by, for example, a proportional integral derivation (PID) control method so that the fixing belt temperature TB changes in the vicinity of a control target temperature Tc determined according to the machine state. The PID control method is a kind of feedback control method and control of an input value based on three factors, that is, a deviation between an output value and a target value, the integral, and the differential.

[0074] The second temperature sensor 382 detects the fixing belt temperature TB at a position closer to an outlet of the nip SN than the radiant light receiving surface, and the controller 400 calculates a difference between the fixing belt temperature TB and the nip formation member temperature TN, that is, (TN - TB) to compare the fixing belt temperature TB with the nip formation member temperature TN. Based on the difference (TN - TB), the controller 400 can accurately estimate an amount of heat that transfers from the nip formation member 380 to the fixing belt 310 in the nip SN and, based on the estimation, determine the amount of power to be supplied to the halogen heater 361.

[0075] Specifically, the first temperature sensor 381 and the second temperature sensor 382 are arranged in an outlet side of the nip SN, that is, upstream in the rotation direction of the fixing belt 310 from an upstream end of the radiant light receiving surface. A distance D (mm) from the upstream end of the radiant light receiving surface to each of the first temperature sensor 381 and the second temperature sensor 382 is equal to or larger than a product of a control cycle S (seconds) of the halogen heater 361 and a rotation speed V (mm / second) of the fixing belt, that is, ($S \times V \leq D$). The above-described configuration enables the controller 400 to immediately determine a control parameter of the halogen heater 361, that is, a parameter of an amount of heat supplied to the fixing belt 310 and the nip formation member 380 at a next

timing based on the detected fixing belt temperature TB.

[0076] In the present embodiment, both the first temperature sensor 381 and the second temperature sensor 382 are arranged in the above-described range ($S \times V \leq D$), but arranging at least one of the first temperature sensor 381 and the second temperature sensor 382 in the above-described range can provide the effect to some extent. That is, arranging at least one of the first temperature sensor 381 and the second temperature sensor 382 in the above-described range enables the controller 400 to immediately determine the parameter of an amount of heat supplied to the fixing belt 310 and the nip formation member 380 at a next timing based on the detected fixing belt temperature TB to some extent.

[0077] Disposing both the first temperature sensor 381 and the second temperature sensor 382 at positions close to the outlet of the nip SN enables accurate detection of the temperature difference between the fixing belt 310 and the nip formation member 380 at the nip SN, that is, (TN - TB) and accurate detection of the amount of heat transfer between the fixing belt 310 and the nip formation member 380. As a result, the controller 400 can accurately determine the power to be supplied to the halogen heater 361. That is, correction of the power supplied to the halogen heater 361 based on the determined power enables accurately keeping the fixing belt temperature TB in the vicinity of the control target temperature Tc, improving fixing property, and reducing the unnecessary power consumption.

[0078] As illustrated in FIGS. 2B and 3, the first temperature sensor 381 and the second temperature sensor 382 are arranged inside the range corresponding to the sheet conveyance span of the sheet having the smallest width, which is used in the image forming apparatus 100, in the axial direction of the fixing belt 310. In the above-described configuration, the controller 400 can accurately estimate the necessary power because temperature rise that occurs outside the sheet conveyance span when small size sheets pass through the fixing device does not affect the temperatures detected by the first temperature sensor 381 and the second temperature sensor 382.

[0079] On the other hand, arranging the first temperature sensor 381 and the second temperature sensor 382 inside the range corresponding to the sheet conveyance span of the sheet having the smallest width may cause a risk that the temperature outside the sheet conveyance span exceeds the upper limit temperature of the fixing device 300, causing melting and damage of the fixing device 300. Therefore, as illustrated in FIGS. 2B and 3, in addition to the first temperature sensor 381 and the second temperature sensor 382, a third temperature sensor 383 is arranged outside a sheet conveyance span of the sheet having the largest width, which is used in the image forming apparatus 100, in the axial direction of the fixing belt 310 and, in the circumferential direction of the fixing belt 310, in an area radiated by the radiant light from the halogen heater 361.

[0080] The third temperature sensor 383 is arranged at a position at which the temperature of the fixing belt 310 is most likely to rise, that is, the position on the radiant light receiving surface outside the sheet conveyance span of the sheet having the largest width in the axial direction of the fixing belt 310. The third temperature sensor 383 can prevent damage to the fixing device 300 due to excessive temperature rise of the fixing belt 310. That is, when the temperature detected by the third temperature sensor 383 exceeds the upper limit temperature, the controller 400 performs a control that reduces the temperature detected by the third temperature sensor 383 to be equal to or lower than the upper limit temperature, such as interruption of a printing operation, productivity reduction, and lowering the control target temperature Tc.

[0081] The controller 400 determines the power supplied to the halogen heater 361 using the PID control as described above. However, the temperature TN of the nip formation member 380 changes the amount of heat transfer between the fixing belt 310 and the nip formation member 380 in the nip SN.

[0082] Therefore, the controller 400 corrects the power based on the difference (TN - TB) between temperatures detected by the first temperature sensor 381 and the second temperature sensor 382. The correction of the power may be calculated by using, for example, a relational expression between the temperature difference and the power obtained in advance or corrected by switching coefficients of the PID control or the control target temperatures Tc when the difference (TN - TB) between temperatures detected by the first temperature sensor 381 and the second temperature sensor 382 exceeds a threshold temperature.

[0083] With reference to FIGS. 5A to 5C, a description is given of effects of the PID control for the fixing belt temperature TB.

[0084] FIGS. 5A and 5B are graphs each illustrating a change of the fixing temperature TB and a change of the temperature of the nip formation member TN when the controller 400 performs the PID control to control the power supplied to the halogen heater 361 based on the fixing belt temperature TB detected by the second temperature sensor 382. FIG. 5C is a graph illustrating the change of the fixing temperature TB and the change of the temperature of the nip formation member TN when the controller 400 performs the PID control to control the power supplied to the halogen heater 361 based on the difference (TN - TB) between temperatures detected by the first temperature sensor 381 and the second temperature sensor 382.

[0085] The sensitivity (responsiveness) to the temperature rise of the fixing belt 310 when a predetermined power is supplied to the halogen heater 361 depends on the temperature TN of the nip formation member 380. That is, since the nip formation member 380 that is sufficiently warmed absorbs only a little amount of radiant heat from the halogen heater 361, increase of the radiant heat from the halogen heater 361 immediately causes

temperature rise of the fixing belt 310.

[0086] In contrast, since the nip formation member 380 that is not sufficiently warmed absorbs a lot of radiant heat from the halogen heater 361, sensitivity of the temperature rise of the fixing belt 310 to the increase of the radiant heat from the halogen heater 361 becomes low.

[0087] As described above, the temperature TN of the nip formation member 380 changes the sensitivity of the temperature rise of the fixing belt 310. FIG. 5A is a graph illustrating the fixing belt temperature TB and the temperature TN of the nip formation member 380 under the PID control using a temperature control parameter suitably set for the nip formation member 380 sufficiently warmed. As illustrated in FIG. 5A, relatively small power is supplied to the halogen heater 361 even when the fixing belt temperature TB is low. This is because the above-described temperature control parameter of the PID control is determined based on the state in which increase of the radiant heat from the halogen heater 361 immediately causes temperature rise of the fixing belt 310 as described above.

[0088] In this case, if the nip formation member 380 is sufficiently warmed, the fixing belt temperature TB is properly controlled. However, even if the nip formation member 380 is not sufficiently warmed, the controller 400 performs the PID control using the temperature control parameter suitably set for the nip formation member 380 sufficiently warmed to control the power supplied to the halogen heater 361, and the relatively small power is supplied to the halogen heater 361 even when the fixing belt temperature TB drops.

[0089] The nip formation member 380 that is not sufficiently warmed absorbs radiant heat stored in the fixing belt 310. As a result, the temperature TB of the fixing belt 310 does not rise easily. Therefore, as illustrated in a left side of the graph in FIG. 5A, the fixing belt temperature TB largely drops, and fixing failure may occur.

[0090] On the contrary, FIG. 5B is a graph illustrating the fixing belt temperature TB and the temperature TN of the nip formation member 380 under the PID control using a temperature control parameter suitably set for the nip formation member 380 is not sufficiently warmed. As illustrated in FIG. 5B, relatively large power is supplied to the halogen heater 361 when the fixing belt temperature TB is low because the sensitivity of the temperature rise of the fixing belt 310 to the increase of the radiant heat from the halogen heater 361 is low.

[0091] In this case, if the nip formation member 380 is not sufficiently warmed, the fixing belt temperature TB is properly controlled. However, even when the nip formation member 380 is sufficiently warmed, the controller 400 performs the PID control using the temperature control parameter suitably set for the nip formation member 380 that is not sufficiently warmed to control the power supplied to the halogen heater 361, and too much large power is supplied to the halogen heater 361 when the fixing belt temperature TB drops.

[0092] Since the nip formation member 380 sufficiently

warmed does not absorb much radiant heat, most of the radiant heat of the halogen heater 361 is transferred to the fixing belt 310, and the fixing belt temperature TB rises at a stroke. As a result, large temperature ripple of the fixing belt temperature TB occurs as illustrated in a right side of the graph in FIG. 5B. The large temperature ripple results in wasteful power consumption.

[0093] As described above, the PID control of the halogen heater 361 using the fixing belt temperature TB detected by the second temperature sensor 382 is unstable, and the performance of the temperature control is poor because actual temperatures of the fixing belt 310 are not estimated. In the embodiment of the present disclosure, using the difference (TN - TB) between temperatures detected by two temperature sensors, that is, the first temperature sensor 381 and the second temperature sensor 382, improves the performance of the temperature control of the fixing belt temperature TB. FIG. 5C is a graph illustrating the fixing belt temperature TB and the temperature TN of the nip formation member 380 under the PID control using the difference (TN - TB).

[0094] That is, based on the difference (TN - TB) between temperatures detected by two temperature sensors, that is, the first temperature sensor 381 and the second temperature sensor 382, the controller 400 switches the parameters such as the coefficients of the PID control when the difference between the nip formation member temperature TN and the fixing belt temperature TB becomes small, which is the center position of the graph in FIG. 5C.

[0095] Specifically, in the left side of the center position of the graph in FIG. 5C, like the left side of the graph in FIG. 5B, the temperature control parameter of the PID control is suitably set for the nip formation member 380 not sufficiently warmed. Additionally, in the right side of the center position of the graph in FIG. 5C, like the right side of the graph in FIG. 5A, the temperature control parameter of the PID control is suitably set for the nip formation member 380 sufficiently warmed.

[0096] The above temperature control can reduce the wasteful power consumption and avoid the occurrence of the fixing failure regardless of the nip formation member temperature TN. In the configuration including a plurality of heat transfer paths from the halogen heater 361, the above-described configuration can accurately keep the temperature of the fixing belt 310 in the vicinity of the control target temperature Tc, reduce the wasteful power consumption, and avoid the occurrence of the fixing failure.

[0097] Finally, a description is given of a method whether the controller 400 controls the power supplied to the halogen heater 361 based on the temperatures detected by the first temperature sensor 381 and the second temperature sensor 382.

[0098] If inputting dummy signals relating to detected temperature values to a signal line extending from the first temperature sensor 381 to the controller 400 causes any change of a temperature control state of the halogen

heater 361 such as a change of wave of measured temperatures, the controller 400 controls the power supplied to the halogen heater 361 based on data detected by the first temperature sensor 381.

5 **[0099]** Similarly, if inputting dummy signals relating to detected temperature values to a signal line extending from the second temperature sensor 382 to the controller 400 causes any change of the temperature control state of the halogen heater 361 such as the change of wave of measured temperatures, the controller 400 controls the power supplied to the halogen heater 361 based on data detected by the second temperature sensor 382.

10 **[0100]** In addition, if the temperature control state of the halogen heater 361 such as the change of wave of measured temperatures when dummy signals relating to detected temperature values are input to the signal lines extending from the first temperature sensor 381 and the second temperature sensor 382 to the controller 400 is different from the temperature control state of the halogen heater 361 such as the change of wave of measured temperatures when dummy signals relating to detected temperature values are input to either the signal line extending from the first temperature sensor 381 to the controller 400 or the signal line extending from the second temperature sensor 382 to the controller 400, the controller 400 controls the power supplied to the halogen heater 361 based on data detected by both the first temperature sensor 381 and the second temperature sensor 382. The above-described method can confirm whether the controller 400 controls the power supplied to the halogen heater 361 based on the temperatures detected by the first temperature sensor 381 and the second temperature sensor 382.

25 **[0101]** The present disclosure has been described above on the basis of the embodiments, but the present disclosure is not limited to the embodiments. Needless to say, various alterations can be made in the scope of the technical idea described in the scope of the claims. For example, although one halogen heater 361 is used in the above-described embodiments, of course, two or three or more halogen heaters may be used. Alternatively, instead of the halogen heater, for example, induction heating (IH) may be employed as the heater.

30 **[0102]** Numerous additional modifications and variations are possible in light of the above teachings. It is therefore to be understood that, within the scope of the above teachings, the present disclosure may be practiced otherwise than as specifically described herein. With some embodiments having thus been described, it will be obvious that the same may be varied in many ways. Such variations are not to be regarded as a departure from the scope of the present disclosure as defined by the appended claims, and all such modifications are intended to be included within the scope of the present disclosure as defined by the appended claims.

Claims**1.** A heating device (300) comprising:

a rotating member (310) having an endless form;
 a heater (361) disposed inside a loop of the rotating member (310);
 a pressing member (320) disposed opposite the rotating member (310);
 a nip formation member (380) contacting an inner circumferential surface of the rotating member (310) to form a nip (SN) between the pressing member (320) and the rotating member (310);
 a first temperature sensor (381) configured to detect a temperature of the nip formation member (380); and
 a second temperature sensor (382) configured to detect a temperature of the rotating member (310), wherein
 the heater radiates light;
 the rotating member has a light receiving surface which is irradiated with the light from the heater;
 the nip formation member has a light receiving surface which is irradiated with the light from the heater,
 wherein the first temperature sensor (381) is disposed downstream from the nip (SN) in a rotation direction of the rotating member (310), wherein the second temperature sensor (382) is disposed downstream from the first temperature sensor (381) in the rotation direction of the rotating member (310), and
 wherein the heater (361) is controlled based on a difference in values detected by the first temperature sensor (381) and the second temperature sensor (382).

2. The heating device (300) according to claim 1, further comprising a controller (400) configured to control the heater (361).

3. The heating device (300) according to claim 1, further comprising a controller (400) disposed outside the heating device (300) and configured to control the heater (361).

4. The heating device (300) according to any one of claims 1 to 3, further comprising a reflector (370) facing the heater (361).

5. The heating device (300) according to any one of claims 1 to 4,
 wherein the first temperature sensor (381) and the second temperature sensor (382) are disposed in an axial direction of the rotating member (310) within a

range through which a sheet having a smallest width of a plurality of sheets having different widths in the axial direction of the rotating member (310) passes in the nip (N)..

6. The heating device (300) according to any one of claims 1 to 5,
 wherein the heater is located between the respective light receiving surfaces of the rotating member and the nip formation member.

7. The heating device (300) according to claim 6,
 wherein the second temperature sensor (382) is disposed upstream from an upstream end of the light receiving surface of the rotating member in a rotation direction of the rotating member (310) at a distance (D) equal to or larger than a product of a control cycle (S) of the heater (361) in units of seconds and a rotation speed (V) of the rotating member (310) in units of millimeters per second.

8. The heating device (300) according to claim 6,
 further comprising a third temperature sensor (383) configured to detect a temperature of the rotating member (310),
 wherein the third temperature sensor (383) is disposed on the light receiving surface outside a range in an axial direction of the rotating member (310), the range through which a sheet having a largest width of a plurality of sheets having different widths in the axial direction of the rotating member (310) and passing through the nip (SN) passes in the nip (SN).

9. A fixing device (300) comprising the heating device (300) according to any one of claims 1 to 8,
 wherein a recording medium bearing an unfixed toner image passes through the nip (SN).

10. An image forming apparatus comprising the fixing device according to claim 9.

Patentansprüche

1. Heizvorrichtung (300), Folgendes umfassend:

ein rotierendes Element (310) mit einer endlosen Form;
 ein Hezelement (361), das innerhalb einer Schleife des rotierenden Elements (310) angeordnet ist;
 ein Presselement (320), das gegenüber dem rotierenden Element (310) angeordnet ist;
 ein Spaltbildungselement (380), das mit einer inneren Umfangsfläche des rotierenden Elements (310) in Kontakt steht, um einen Spalt (SN) zwischen dem Presselement (320) und dem rotierenden Element (310) zu bilden;

- einen ersten Temperatursensor (381), der konfiguriert ist, um eine Temperatur des Spaltbildungselements (380) zu erfassen; und einen zweiten Temperatursensor (382), der konfiguriert ist, um eine Temperatur des rotierenden Elements (310) zu erfassen, wobei das Heizelement Licht abstrahlt; das rotierende Element eine Lichtempfangsfläche aufweist, die mit dem Licht von dem Heizelement bestrahlt wird; das Spaltbildungselement eine Lichtempfangsfläche aufweist, die mit dem Licht von dem Heizelement bestrahlt wird, wobei der erste Temperatursensor (381) stromabwärts vom Spalt (SN) in einer Rotationsrichtung des rotierenden Elements (310) angeordnet ist, wobei der zweite Temperatursensor (382) stromabwärts von dem ersten Temperatursensor (381) in der Rotationsrichtung des rotierenden Elements (310) angeordnet ist, und wobei das Heizelement (361) auf der Grundlage einer Differenz zwischen den von dem ersten Temperatursensor (381) und dem zweiten Temperatursensor (382) erfassten Werten gesteuert wird.
2. Heizvorrichtung (300) nach Anspruch 1, ferner umfassend eine Steuerung (400), die konfiguriert ist, um das Heizelement (361) zu steuern.
 3. Heizvorrichtung (300) nach Anspruch 1, ferner umfassend eine Steuerung (400), die außerhalb der Heizvorrichtung (300) angeordnet und konfiguriert ist, um das Heizelement (361) zu steuern.
 4. Heizvorrichtung (300) nach einem der Ansprüche 1 bis 3, ferner umfassend einen Reflektor (370), der dem Heizelement (361) zugewandt ist.
 5. Heizvorrichtung (300) nach einem der Ansprüche 1 bis 4, wobei der erste Temperatursensor (381) und der zweite Temperatursensor (382) in einer axialen Richtung des rotierenden Elements (310) innerhalb eines Bereichs angeordnet sind, durch den ein Blatt mit der kleinsten Breite einer Vielzahl von Blättern mit unterschiedlichen Breiten in der axialen Richtung des rotierenden Elements (310) in dem Spalt (N) hindurchläuft.
 6. Heizvorrichtung (300) nach einem der Ansprüche 1 bis 5, wobei sich das Heizelement zwischen den jeweiligen Lichtempfangsflächen des rotierenden Elements und des Spaltbildungselements befindet.
 7. Heizvorrichtung (300) nach Anspruch 6,
- wobei der zweite Temperatursensor (382) stromaufwärts von einem stromaufwärtigen Ende der Lichtempfangsfläche des rotierenden Elements in einer Rotationsrichtung des rotierenden Elements (310) in einem Abstand (D) angeordnet ist, der gleich oder größer ist als ein Produkt aus einem Steuerzyklus (S) des Heizelements (361) in Einheiten von Sekunden und einer Rotationsgeschwindigkeit (V) des rotierenden Elements (310) in Einheiten von Millimetern pro Sekunde.
8. Heizvorrichtung (300) nach Anspruch 6, ferner umfassend einen dritten Temperatursensor (383), der konfiguriert ist, um eine Temperatur des rotierenden Elements (310) zu erfassen, wobei der dritte Temperatursensor (383) auf der Lichtempfangsfläche außerhalb eines Bereichs in einer axialen Richtung des rotierenden Elements (310) angeordnet ist, wobei der Bereich, durch den ein Blatt mit der größten Breite einer Vielzahl von Blättern mit unterschiedlichen Breiten in der axialen Richtung des rotierenden Elements (310) und durch den Spalt (SN) hindurchläuft, im Spalt (SN) verläuft.
 9. Fixiervorrichtung (300), umfassend die Heizvorrichtung (300) nach einem der Ansprüche 1 bis 8, wobei ein Aufzeichnungsmedium, das ein unfixiertes Tonerbild trägt, durch den Spalt (SN) hindurchläuft.
 10. Bilderzeugungsvorrichtung, umfassend die Fixiervorrichtung nach Anspruch 9.

Revendications

1. Dispositif chauffant (300) comprenant :

- un élément rotatif (310) présentant une forme sans fin ;
- un radiateur (361) disposé à l'intérieur d'une boucle de l'élément rotatif (310) ;
- un élément de pression (320) disposé à l'opposé de l'élément rotatif (310) ;
- un élément de formation de pince (380) entrant en contact avec une surface circonférentielle interne de l'élément rotatif (310) pour former une pince (SN) entre l'élément de pression (320) et l'élément rotatif (310) ;
- un premier capteur de température (381) configuré pour détecter une température de l'élément de formation de pince (380) ; et
- un deuxième capteur de température (382) configuré pour détecter une température de l'élément de rotation (310), dans lequel le radiateur irradie de la lumière ;
- l'élément de rotation présente une surface de

- réception de lumière qui est irradiée avec la lumière en provenance du radiateur ;
l'élément de formation de pince présente une surface de réception de lumière qui est irradiée avec la lumière en provenance du radiateur, dans lequel le premier capteur de température (381) est disposé en aval de la pince (SN) dans une direction de rotation de l'élément rotatif (310), dans lequel le deuxième capteur de température (382) est disposé en aval du premier capteur de température (381) dans la direction de rotation de l'élément rotatif (310), et dans lequel le radiateur (361) est commandé sur la base d'une différence de valeurs détectées par le premier capteur de température (381) et le deuxième capteur de température (382).
2. Dispositif chauffant (300) selon la revendication 1, comprenant en outre un dispositif de commande (400) configuré pour commander le radiateur (361). 20
 3. Dispositif chauffant (300) selon la revendication 1, comprenant en outre un dispositif de commande (400) disposé à l'extérieur du dispositif chauffant (300) et configuré pour commander le radiateur (361). 25
 4. Dispositif chauffant (300) selon l'une quelconque des revendications 1 à 3, comprenant en outre un réflecteur (370) faisant face au radiateur (361). 30
 5. Dispositif chauffant (300) selon l'une quelconque des revendications 1 à 4, dans lequel le premier capteur de température (381) et le deuxième capteur de température (382) sont disposés dans une direction axiale de l'élément rotatif (310) au sein d'une plage à travers laquelle une feuille présentant la plus petite largeur d'une pluralité de feuilles présentant des largeurs différentes dans la direction axiale de l'élément rotatif (310) passe dans la pince (N). 35 40
 6. Dispositif chauffant (300) selon l'une quelconque des revendications 1 à 5, dans lequel le radiateur est situé entre les surfaces de réception de lumière respectives de l'élément rotatif et de l'élément de formation de pince. 45
 7. Dispositif chauffant (300) selon la revendication 6, dans lequel le deuxième capteur de température (382) est disposé en amont d'une extrémité amont de la surface de réception de lumière de l'élément rotatif dans une direction de rotation de l'élément rotatif (310) à une distance (D) égale ou supérieure à un produit d'un cycle de commande (S) du radiateur (361) en unités de secondes et une vitesse de rotation (V) de l'élément rotatif (310) en unités de milli- 50 55
- mètres par seconde.
8. Dispositif chauffant (300) selon la revendication 6, comprenant en outre un troisième capteur de température (383) configuré pour détecter une température de l'élément rotatif (310), dans lequel le troisième capteur de température (383) est disposé sur la surface de réception de lumière à l'extérieur d'une plage dans une direction axiale de l'élément rotatif (310), la plage à travers laquelle une feuille présentant la plus grande largeur d'une pluralité de feuilles présentant des largeurs différentes dans la direction axiale de l'élément rotatif (310) et passant à travers la pince (SN) passe dans la pince (SN). 5
 9. Dispositif de fixation (300) comprenant le dispositif chauffant (300) selon l'une quelconque des revendications 1 à 8, dans lequel un support d'enregistrement portant une image de toner non fixée passe à travers la pince (SN). 10
 10. Appareil de formation d'image comprenant le dispositif de fixation selon la revendication 9. 15

FIG. 1

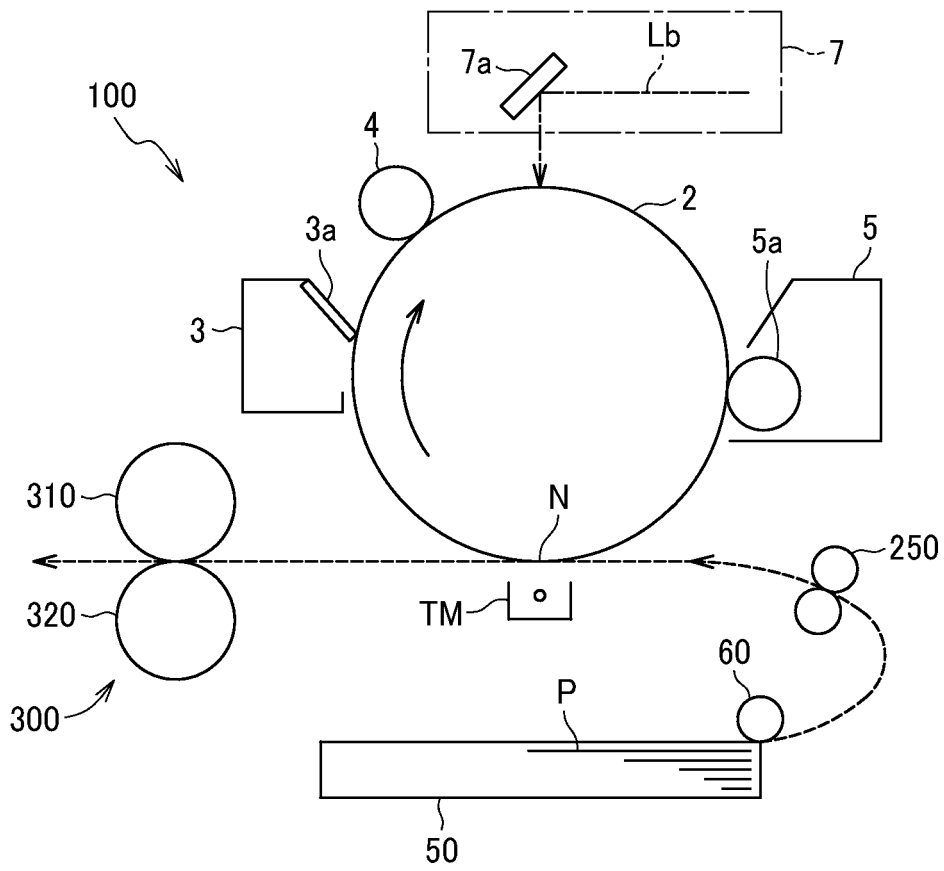

FIG. 2A

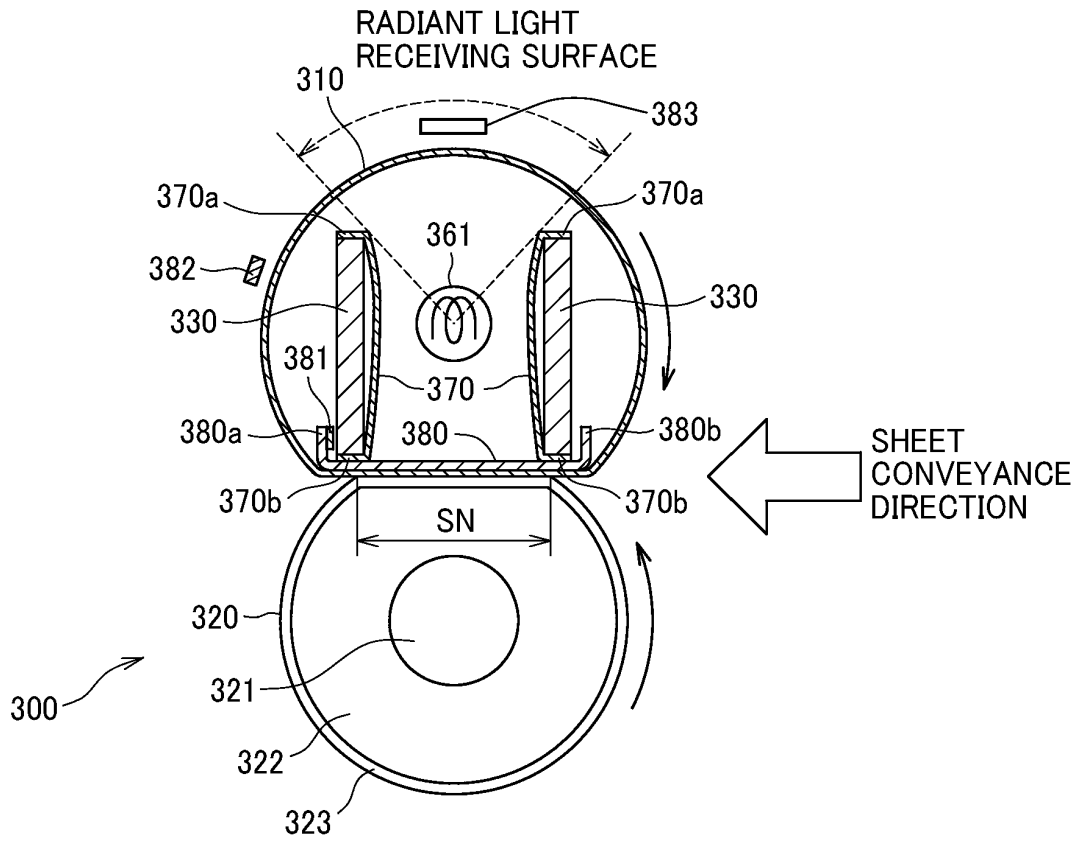

FIG. 2B

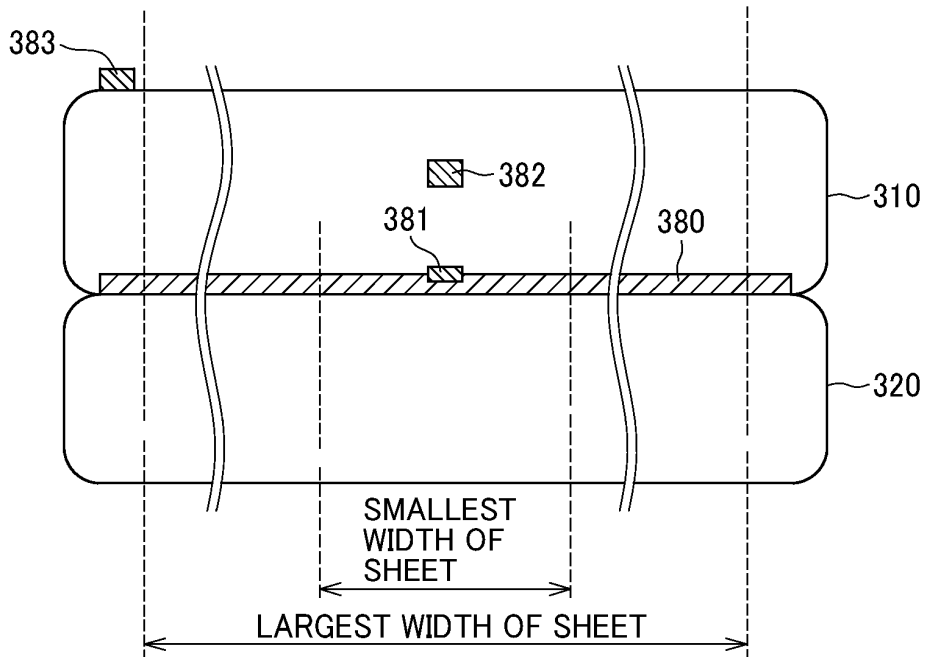

FIG. 3

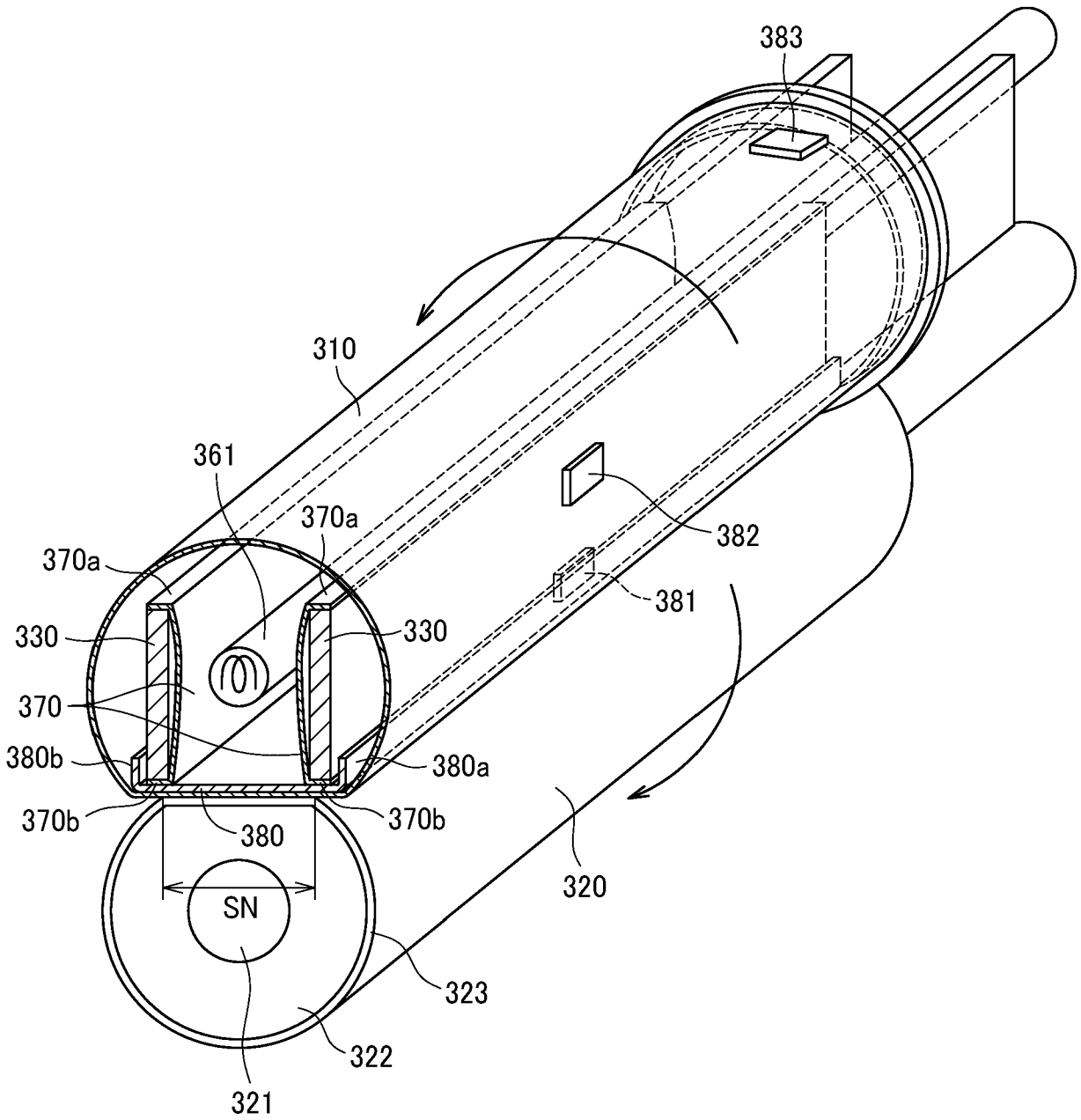

FIG. 4

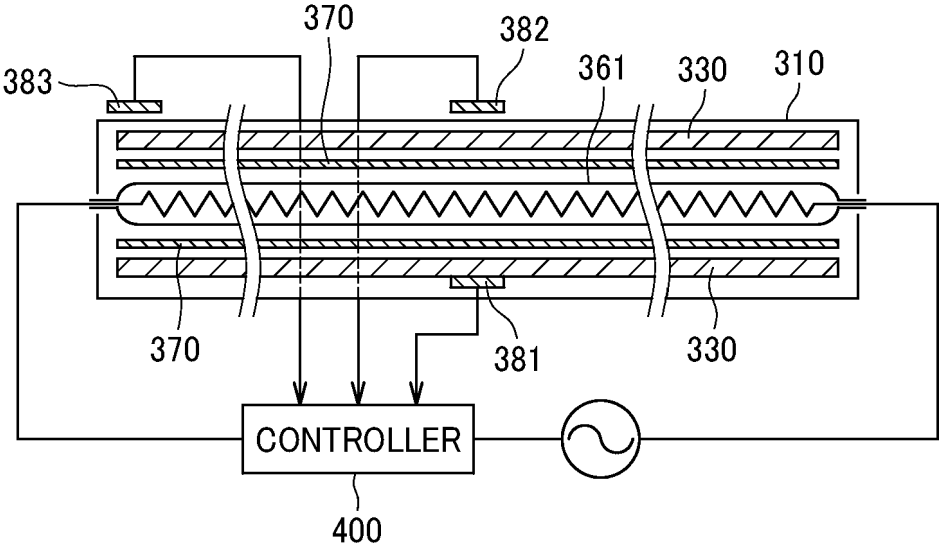

FIG. 5A

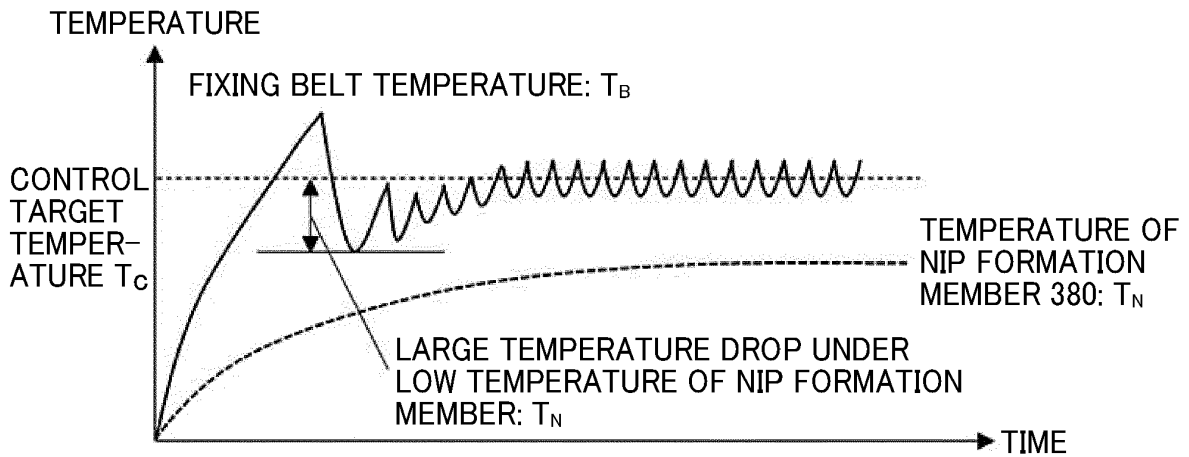

FIG. 5B

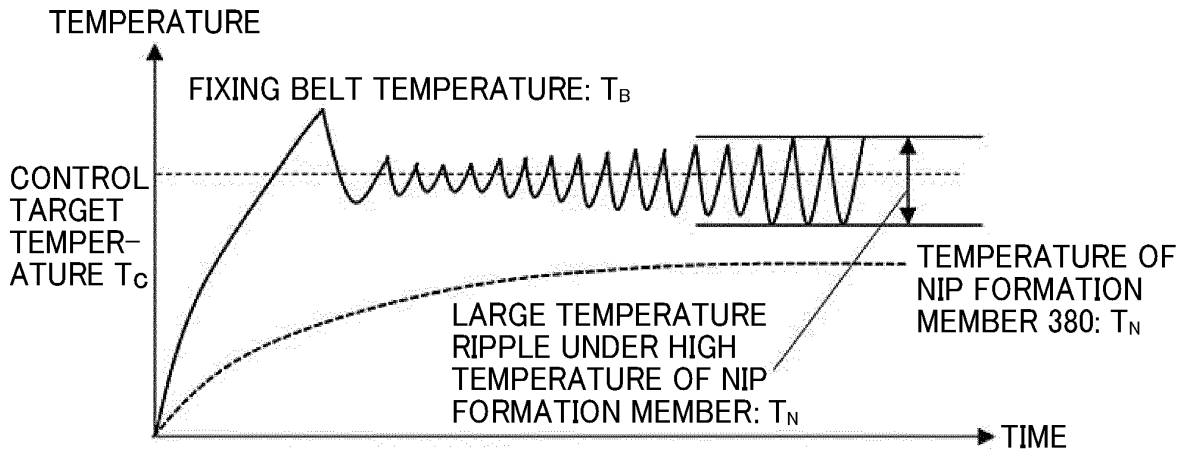
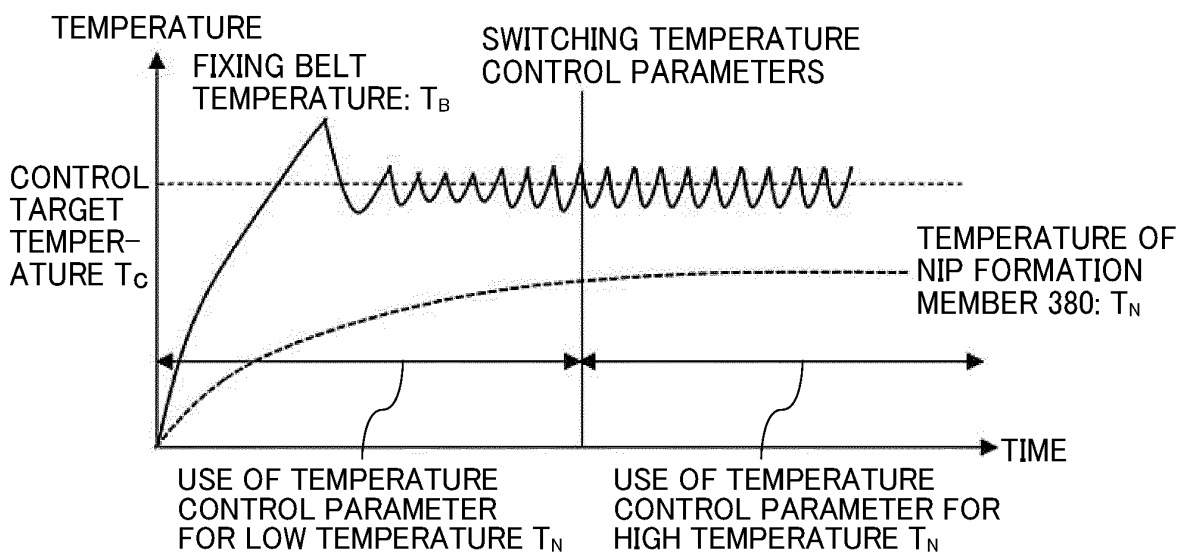

FIG. 5C



REFERENCES CITED IN THE DESCRIPTION

This list of references cited by the applicant is for the reader's convenience only. It does not form part of the European patent document. Even though great care has been taken in compiling the references, errors or omissions cannot be excluded and the EPO disclaims all liability in this regard.

Patent documents cited in the description

- JP 6164014 B [0002]
- JP 2015069094 A [0002]
- US 20140294417 A1 [0004]
- JP 201602442 A [0005]
- JP 2004191966 B [0006]
- JP 2006251479 A [0007]
- EP 1995646 A2 [0008]