



US 20050106339A1

(19) **United States**

(12) **Patent Application Publication**

Baker

(10) **Pub. No.: US 2005/0106339 A1**

(43) **Pub. Date: May 19, 2005**

(54) **PACKAGING LABEL HAVING A TEAR AWAY SPINE**

Publication Classification

(75) **Inventor: Byron L. Baker, York, PA (US)**

(51) **Int. Cl.⁷ B65D 1/00**

(52) **U.S. Cl. 428/34.1; 428/137; 428/43**

Correspondence Address:
MCNEES, WALLACE & NURICK LLC
100 PINE STREET
P.O. BOX 1166
HARRISBURG, PA 17108-1166 (US)

(57) **ABSTRACT**

A removable tag or label for CD/DVD cases that includes a label having opposed portions which adhere to the CD/DVD case to prevent the case from opening. The label includes a removable spine defined along microperforations formed in the label. The spine is removable by tearing along the microperforations for permitting access to the CD/DVD case.

(73) **Assignee: BJK Holdings, Inc., Wilmington, DE**

(21) **Appl. No.: 10/712,366**

(22) **Filed: Nov. 13, 2003**

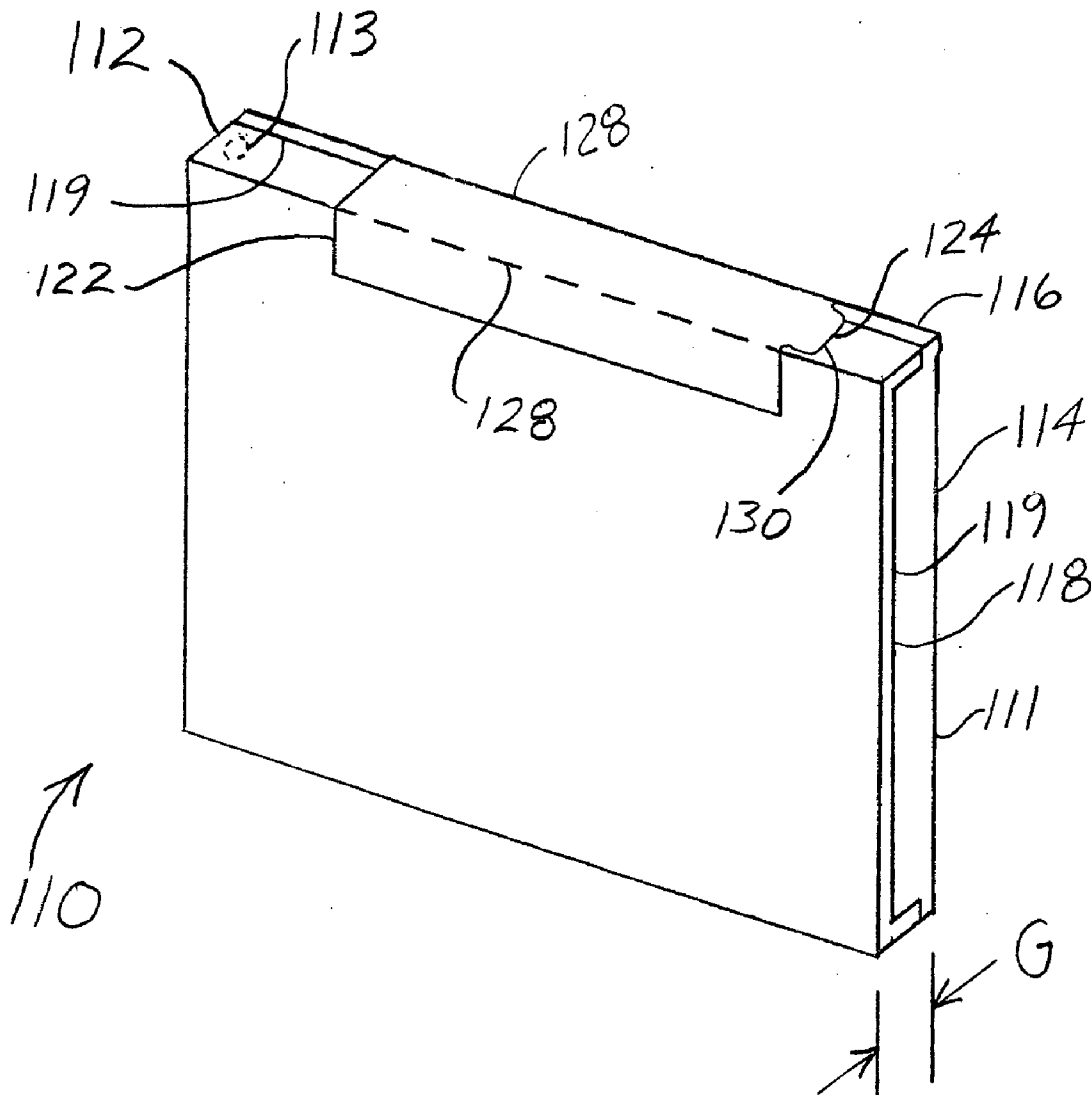

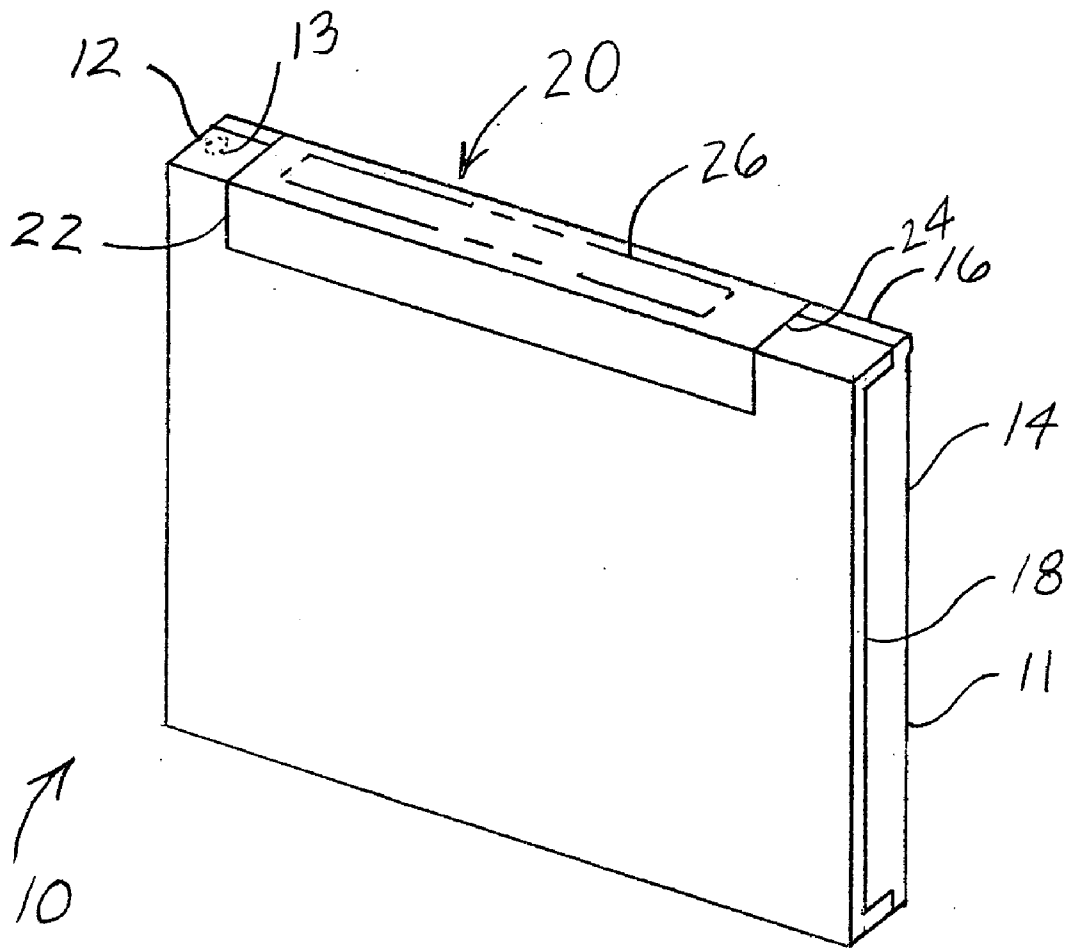

FIG. 1
PRIOR ART

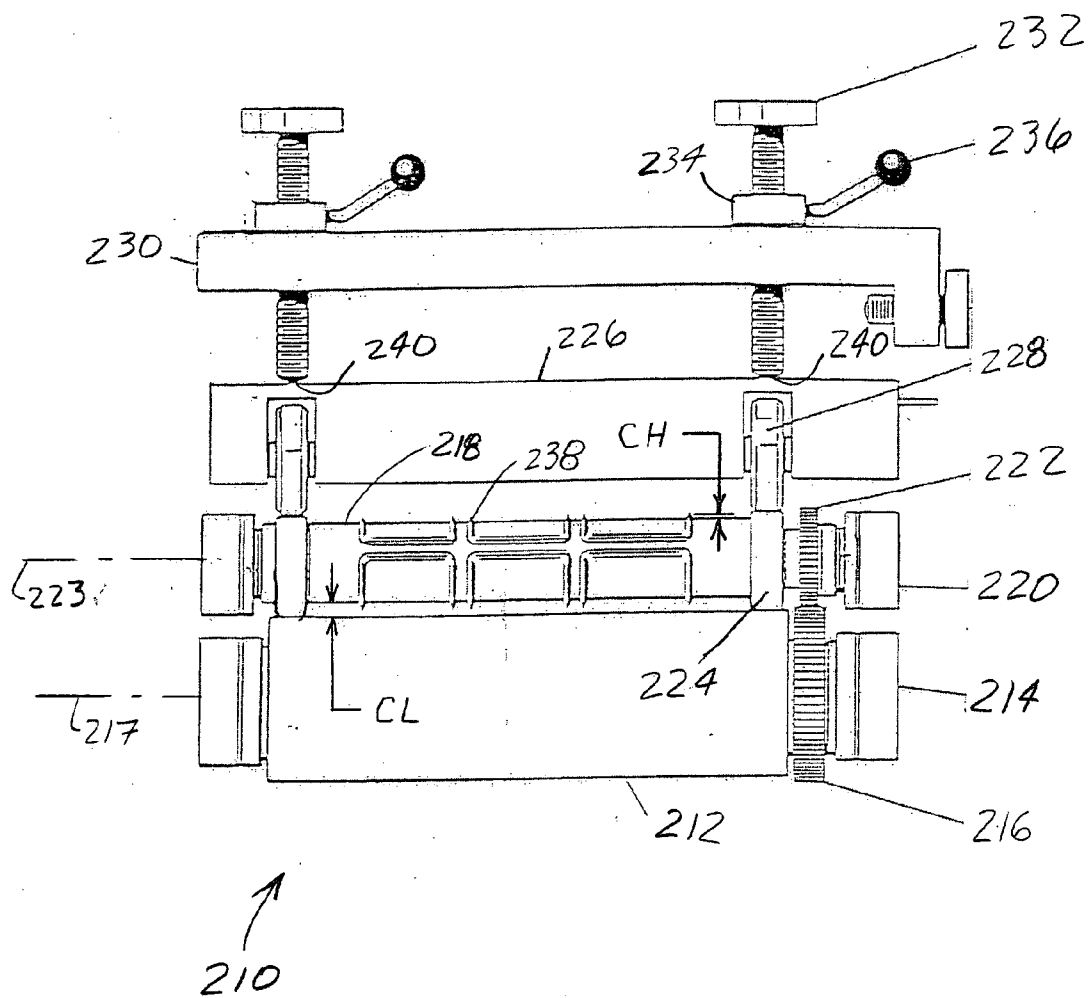

FIG. 3

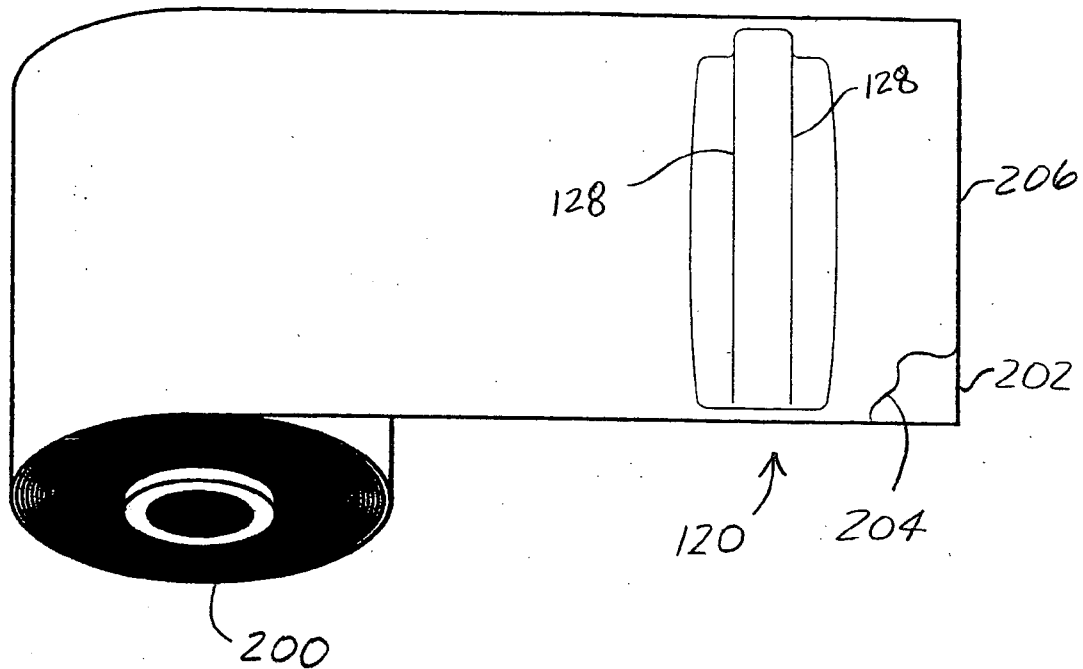

FIG. 4

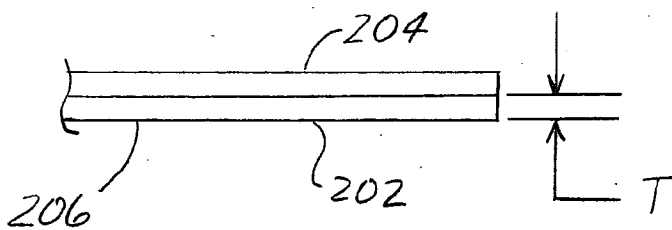

FIG. 8

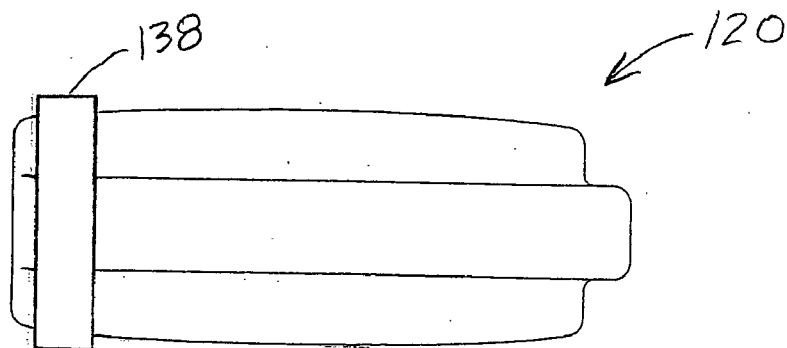

FIG. 7

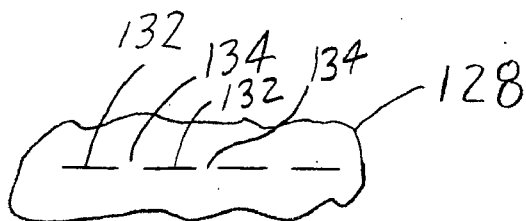

FIG. 6

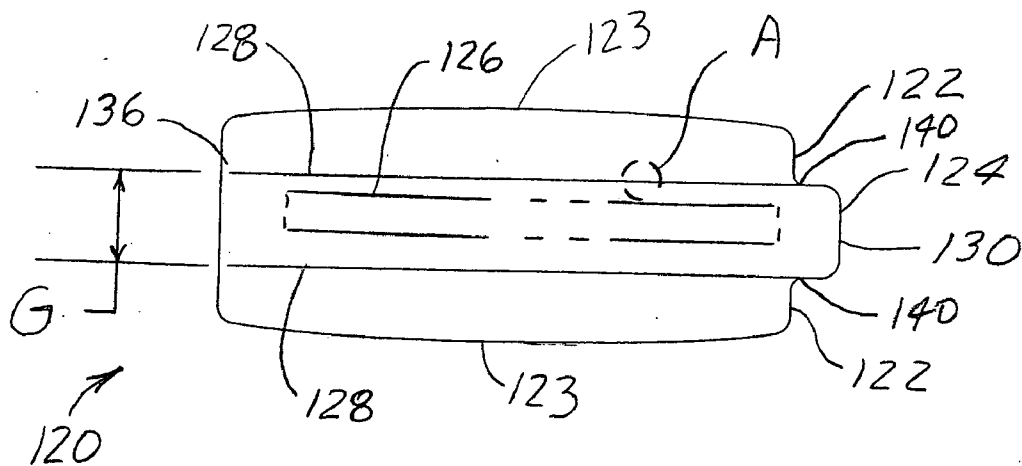

FIG. 5

PACKAGING LABEL HAVING A TEAR AWAY SPINE

BACKGROUND OF THE INVENTION

[0001] The present invention relates generally to labels or tags for use with containers. Specifically, the present invention relates to a label or tag construction having a tear away spine for use with a container.

[0002] Billions of Compact discs (CDs) and digital versatile discs or digital video discs (DVDs) are sold each year. Typically, for individual retail sale, CDs/DVDs are packaged in containers or cases which protect the CD/DVD and provide product identification and promotional information for viewing by a prospective consumer. For example, as shown in FIG. 1, a CD container 10, also referred to as jewel box, typically has a lid 18 and a base or body 11. The lid 18 is rotatable about a hinged end 12 and the lid 18 contacts an opposed latched end 14 bridged by two adjacent ends 16. Each end 16 is narrow, having parallel edges which separate the end 16 from opposed lid 18 and base 11 of the container 10. The CD/DVD stored in the container 10 is accessed by rotating a lid 18 to an open position with respect to the rest of the container 10.

[0003] Packaging of the CD/DVD for individual retail sale typically includes labels or tags 20 that are affixed to at least one of the parallel edges 16 of the closed container 10. The labels 20 typically include two segments 22 or flaps; one of the segments 22 is adhered to the lid 18 and the other segment 22 is adhered to the base 11. A spine 24 is located between the segments 22. The spine 24 may have an indicia area 26 which can include information describing the contents of the container 10, as well as corresponding bar code information. Optionally, the container 10 is then enclosed in a layer of shrink wrap material (not shown). The information in indicia area 26 not only permits identification by consumers of the contents of the container, but also permits retailers to monitor inventory by passing a bar code reader adjacent the information in indicia area 26.

[0004] After purchase of the CD/DVD by a consumer, the layer of shrink wrap material, if present, has to be removed and the label, and more specifically, the spine, must be removed to access the CD/DVD from the container. Alternately, the spine can be torn along its entire length to access the CD/DVD from the container. However, this can be unsightly and may cause the container to adhere to adjacent objects due to the presence of adhesive that is applied to the label. Typically, a sharp tool must be inserted along one end of the spine between the spine and the container, which usually removes only small pieces of the spine with each directed movement of the tool. Since these small pieces are typically adhesive backed, they tend to adhere to the objects they contact, and use of the sharp tool subjects the consumer to the possibility of personal injury and damage to the container or the CD/DVD. This opening process can be an aggravating and time-consuming experience for the consumer.

[0005] The problems associated with accessing a CD/DVD from a container due to the affixed label or tag are not only well known, but unresolved, and continuously lampooned, especially within the music and computer industries. Therefore, what is needed is a label or tag that is compatible with existing manufacturing methods for apply-

ing similar labels to containers for CDs or DVDs and that has a spine that is easily removable in a single piece, without a tool, while leaving remaining label portions with a clean, unobtrusive, professional appearance.

SUMMARY OF THE INVENTION

[0006] One embodiment of the present invention is directed to a removable label for a container comprising a spine, at least one segment disposed adjacent to the spine, and the at least one segment being detachably connected to the spine along a predetermined path. As used herein, the terms tag and label are interchangeable. Upon the installation of the label on a container, the detachment of the at least one segment from the spine along the predetermined path permits a container to be adjusted between an open position and a closed position.

[0007] A further embodiment of the present invention is directed to a removable label comprising a label including at least two segments having opposed first and second surfaces wherein an adhesive is applied to at least a portion of the first surface to adhere the label to a container having a lid and a body with the lid being movable with respect to the body to an open position and a closed position. Upon moving the lid to an open position permits access to an item enclosed within the container, the label preventing the lid from being movable to an open position. Upon removal of at least one segment of the at least two segments along a predetermined path formed in the label, the lid is movable to the open position.

[0008] A still further embodiment of the present invention is directed to a packaging system comprising a container, a label attached to the container, the label having a spine and at least one segment disposed adjacent to the spine. The at least one segment is detachably connected to the spine along a predetermined path. Upon the installation of the label on a container, the detachment of the at least one segment from the spine along the predetermined path permits a container to be adjusted between an open position and a closed position.

[0009] One advantage of the label or tag of the present invention is that it is inexpensive to make.

[0010] Another advantage of the label or tag of the present invention is that it permits removal of the spine in a single, contiguous piece without requiring a tool.

[0011] A further advantage of the label or tag of the present invention is that the remaining portions of the label have a clean, unobtrusive, professional appearance which does not require removal of the remaining label portions, but which can be easily removed in one piece without adhesive residue, if desired.

[0012] A still further advantage of the label or tag of the present invention is that the spine should be removable even if the CD/DVD is "on the shelf" for extended periods of time.

[0013] An additional advantage of the label or tag of the present invention is that it provides tamper evidencing.

[0014] A further advantage of the label or tag of the present invention is that it provides a means for imprinting information used by replicators, retailers and consumers.

[0015] A further advantage of the label or tag of the present invention is that it resists embrittlement to function as intended with containers having extended shelf lives.

[0016] Other features and advantages of the present invention will be apparent from the following more detailed description of the preferred embodiment, taken in conjunction with the accompanying drawings which illustrate, by way of example, the principles of the invention.

BRIEF DESCRIPTION OF THE DRAWINGS

[0017] FIG. 1 is a perspective view of a CD jewel box having a prior art label or tag.

[0018] FIG. 2 is a perspective view of a CD jewel box having a label or tag of the present invention.

[0019] FIG. 3 is an elevation view of an apparatus for producing the label or tag of the present invention.

[0020] FIG. 4 is a perspective view of a roll of material showing the label or tag produced by the apparatus of the present invention.

[0021] FIG. 5 is a plan view of a label or tag of the present invention.

[0022] FIG. 6 is a partial enlarged view of a microperforation of region "A" taken from FIG. 5 of the present invention.

[0023] FIG. 7 is a plan view of an alternate embodiment of the labeled tag or label of the present invention.

[0024] FIG. 8 is an enlarged partial elevation view of material being dispensed from a roll to form the label or tag of the present invention.

[0025] Wherever possible, the same reference numbers will be used throughout the drawings to refer to the same or like parts.

DETAILED DESCRIPTION OF THE INVENTION

[0026] Referring to FIGS. 2 and 5, a removable or detachable label or tag 120 for containers is shown. As used herein, the terms label and tag are interchangeable. In one embodiment, label 120 is used to assist in maintaining a container 110 in a closed position. Container 110 typically includes a lid 118 and a base or body 111. Lid 118 is rotatable with respect to base 111 about a hinge 113, defining a hinged end 112, and with container 110 in a closed position, lid 118 contacts an opposed latched end 114. The hinged end 112 and latched end 114 of the container 110 are bridged by two adjacent, substantially parallel, side portions 116. The product, e.g., CD, DVD, video game, etc., which is entirely enclosed within container 110 when lid 118 is in a closed position, is accessed by rotating the lid 118 about hinge 113 away from base 111 to an open position. In a preferred embodiment of the present invention, the container 110 is a container, such as a jewel box, for a CD, DVD or video game. However, it is to be understood that the label or tag of the present invention can be applied to any type of container requiring a removable label or tag, not necessarily only a rigid container having a hinge or rotatable lid.

[0027] Typically, label 120 is affixed to at least one of the parallel side portions 116 of the closed container 110. Label

120 preferably includes a pair of opposed segments 122 separated by a spine 124 which is defined by a pair of microperforations 128 formed in the label 120. Spine 124 preferably has information indicating the contents of the container and bar code information. However, the spine may not include any information. Preferably, spine 124 is placed over side portion 116 such that microperforations 128 substantially coincide with the edges or corners of side portion 116, and segments or flaps 122 are placed into contact with lid 118 and base 111, such as by folding the segments 122 along the edges of side portion 116. Preferably, an adhesive layer is applied to at least a portion of label 120 to maintain label 120 in this contact position with container 110. However, any method of affixing label 120 to the container 110, such as chemical treatment, heat treatment or fasteners known in the art, may be used which is compatible with the functioning of the label 120. The spine 124 also includes at least one tab or extending portion 130 which extends from at least one end of spine 124.

[0028] Upon grasping a tab or extending portion 130, and pulling away from side portion 116, spine 124 tears substantially along microperforations 128 so that spine 124 is easily removed in one contiguous piece. Upon removal of spine 124, a seam 119 which defines the interface between lid 118 and base 111 is unencumbered, permitting lid 118 to be rotated about hinge 113 with respect to base 111 to an open position for access to the product or item housed therein. While the advantages of this invention will be described with reference to hinged containers, the teachings of the invention are generally applicable to any container on which the label may be placed to prevent access to an item contained within the container, but to then provide improved access to the item within the container upon the removal of the spine, and evidence of tampering with the container if such access is unauthorized. Thus, a container is not required to have a lid, or be structurally rigid, so long as the label functions as intended.

[0029] FIGS. 3-8 refer to a die assembly 210 for forming label 120 comprising a base roller or anvil 212 that is rotatably carried about axis 217 by bearing block 214. Preferably interposed between base roller 212 and bearing block 214 is a gear 216 that is fixed to base roller 212. A cutting die 218 adjacent base roller 212 includes at least one cutter 238, and preferably a plurality of cutters 238, such as three, for forming the profile of label 120 in tape 206 from roll 200 (FIG. 4) that is fed between cutter die 218 and base roller 212. Cutting die 218 further includes at least one, and preferably at least two, die bearers 224 for maintaining a desired spacing between base roller 212 and cutting die 218. Additionally, cutting die 218 includes a gear 222 that is fixed to cutting die 218 for rotatably driving cutting die 218 about an axis 223 by meshing with gear 216 of base roller 212 which is driven by a driving means (not shown). Cutting die 218 is rotatably carried about axis 223 by bearing block 220.

[0030] To control the spacing between base roller 212 and cutting die 218, a roller block 226 rotatably carries pressure rollers 228 which are brought into contact with die bearers 224. The position of die block 226 is controlled by a fixed pressure bridge 230 which is adapted to threadedly receive at least one, and preferably at least two, pressure screws 232. Pressure screws 232 are actuated with respect to pressure bridge 230 until ends 240 of pressure screw 232 contact roller block 226. Pressure screws 232 exert radial forces on

roller block 226, which causes pressure rollers 228 to likewise apply forces to die bearers 224 which decreases the spacing or clearance between cutting die 218 and base roller 212, that is identified in FIG. 3 as "CL." When properly adjusted, the height of cutters 238, or the amount of protrusion cutters 238 radially outwardly extend from the surface of cutting die 218, identified in FIG. 3 as "CH" for cutter height, subtracted from spacing CL should substantially equal the thickness of carrier paper 202 of tape 206 (FIGS. 4 and 8) so that cutters 238 cut the profile of label 120 into film 204 of tape 206 of roll 200. This is stated symbolically in equation 1, where "T" is the thickness of carrier layer 202 (FIG. 8), although it is, of course, realized that cutters 238 may extend or cut partially into carrier layer 202 without cutting through carrier layer 202.

$$CL-CH=T$$

[1]

[0031] To ensure the proper adjustment setting is maintained, a lock nut 234, having a handle 236 for ease of use, is actuated to forcefully abut lock nut 234 against pressure bridge 230 to prevent pressure screw 232 from actuating with respect to pressure bridge 230.

[0032] Referring to FIGS. 4-7, label 120 comprises a layer of film material 204 preferably having sufficient cross-directional tear properties so that the spine 124 tears along microperforations 128, since it is highly preferred to maintain the orientation of label 120, and microperforations 128, with respect to tape 206 (FIG. 4). Known film layer constructions have lacked sufficient cross-directional tear properties to permit removal of the spine in a contiguous piece. By maintaining this orientation, label 120 is compatible with existing packaging equipment. A preferred label material is polyethylene having a thickness of about 3.4 mils (0.0034 inches) with a backing or release layer of siliconized polyester with a silicon release coating, the release layer having a thickness of about 1 mil (0.001 inches). Although other label materials may be configured for use, polyethylene material in combination with the sized microperforations, which are described in further detail below, provide superior results. Applicant has discovered that the preferred material still functions as desired, even when the product, that is, the container housing an item to which the label is affixed, is subjected to an extended shelf life prior to opening the container. Stated another way, this combination of label material and microperforations is resistant to material embrittlement.

[0033] In the case of CD jewel boxes, microperforations 128 are separated by a gap indicated by "G" which substantially corresponds to the distance between the edges of side portion 116 (see FIGS. 2 and 5). In this arrangement, upon removal of spine 124 by tearing along microperforations 128, the resulting edges of the segments 122 adjacent spine 124 which remain attached to container 10 are clean, unobtrusive and have a professional appearance. In other words, it is not necessary to remove the remaining segments 122 from container 10. In contrast, even specially configured tools which may be employed to open CD containers using prior art labels by introducing a slit in the spine, at best, leave protruding flaps of spine material which typically cannot be removed cleanly short of completely removing the label material.

[0034] Preferably, microperforations 128 comprise a series of spaced slits 132 or cuts of uniform length between

ties 134 of uniform length, which ties are typically uncut lengths of label material. However, it is not necessary that either slits 132 or ties 134 be of uniform length. Additionally, it is not necessary that slits 132 be formed entirely through the thickness of film 204, and that ties 134 may be of reduced thickness as compared to the thickness of film 204. In combination with the polyethylene film label material previously discussed, the microperforations 128 preferably includes slits 132 of about 34 mils (0.034 inches) separated by ties 134 of about 8 mils (0.008 inches). To assist the tearing of spine 124 along microperforations 128, preferably each of a pair of junctions 140 located along microperforations 128 adjacent tab 130 begin the microperforation sequence of alternating slits 132 and ties 134 with a slit. In an alternate embodiment (not shown), tab 130 may protrude from each end of spine 124.

[0035] Optionally, for a label having a single tab 130, substantially along the end of spine 124 opposite tab 130 is an extended tie 136, measuring about 50 mils (0.050 inches) for the specific combination of material and microperforations 128. Upon removing spine 124, as previously discussed above, having extended tie 136, material from label segments 122 adjacent the extended tie 136 does not sever cleanly, but plastically distorts at least a portion of the segments 122, providing evidence of tempering. It is also contemplated that this plastically distorted material may change color with respect to the label material as applied onto the container, providing more pronounced visual evidence of tampering. Of course, it is understood by those having skill in the art that once spine 124 is removed, it cannot be replaced.

[0036] Although primarily for manufacturing convenience, the outer edges of label segments 122 may include a nonlinear profile 123 or outermost edge, which permits more uniform material forming loads on the cutting dies 218 during operation of die assembly 210. Referring back to FIG. 3, it is also contemplated that the arrangement of the cutters 238 along the cutting die 218 are not necessarily aligned, and, in fact, are preferably angularly spaced to provide further uniform loading of the cutting die 218 during operation of die assembly 210.

[0037] Referring to FIG. 7, which is a label embodiment otherwise similar to FIG. 6, label 120 may also be configured to include a foil strip 138 having unique holographic markings or other types of desired markings.

[0038] It is also understood that while a single embodiment identifying a particular material and microperforation or extended tie has been discussed, any number of combinations of materials and perforations may be employed that could produce spines that may be similarly removable. It is further understood that in addition to microperforations being of non-uniform spacing, it is also contemplated that the microperforations may be in combination with partial crushing or compressing the label material, or exposure to heat, such as laser die cutting, or other localized treatment along the microperforations or that the slits may not be oriented in-line with the general direction of the microperforation. Additionally, it is understood that the cutting die includes magnetic dies having interchangeable formed sheets formed about the periphery of the magnetic die, and that the cutting die is not required to be cylindrical. It is also understood that the slits may include cutout regions. In other

words, label material may be removed from the label to form cutout regions along the microperforation, and that the resulting geometry of the cutout regions could resemble any geometric shape.

[0039] While the invention has been described with reference to a preferred embodiment, it will be understood by those skilled in the art that various changes may be made and equivalents may be substituted for elements thereof without departing from the scope of the invention. In addition, many modifications may be made to adapt a particular situation or material to the teachings of the invention without departing from the essential scope thereof. Therefore, it is intended that the invention not be limited to the particular embodiment disclosed as the best mode contemplated for carrying out this invention, but that the invention will include all embodiments falling within the scope of the appended claims.

What is claimed is:

- 1. A removable label for a container comprising:
 - a spine;
 - at least one segment disposed adjacent to the spine, the at least one segment being detachably connected to the spine along a predetermined path;
 - wherein upon the installation of the label on a container, the detachment of the at least one segment from the spine along the predetermined path permits a container to be adjusted between an open position and a closed position.
- 2. The removable label of claim 1 wherein the spine and at least one segment are polyethylene.
- 3. The removable label of claim 1 wherein the predetermined path is defined by at least one perforation formed in the label.
- 4. The removable label of claim 1 wherein the spine has at least one extending portion.
- 5. The removable label of claim 1 wherein at least a portion of an edge of the at least one segment is nonlinear.
- 6. The removable label of claim 3 wherein at least a portion of the at least one perforation is of uniform length.
- 7. The removable label of claim 3 wherein the at least one perforation has a length of about 0.034 inches.
- 8. The removable label of claim 3 wherein the predetermined path is defined by at least one tie formed in the label, the at least one tie has a length of about 0.008 inches.
- 9. The removable label of claim 4 wherein removing the spine plastically distorts at least a portion of the at least one segment affixed to the container.

- 10. A removable label comprising:
 - a label including at least two segments having opposed first and second surfaces wherein an adhesive is applied to at least a portion of the first surface to adhere the label to a container having a lid and a body, the lid being movable with respect to the body to an open position and a closed position, wherein moving the lid to an open position permits access to an item enclosed within the container, the label preventing the lid from being movable to an open position;
 - wherein upon removal of at least one segment of the at least two segments along a predetermined path formed in the label, the lid is movable to the open position.
- 11. The removable label of claim 10 wherein the container is a CD jewel box.
- 12. The removable label of claim 10 wherein the container is a DVD container.
- 13. The removable label of claim 10 wherein the predetermined path is defined by at least one perforation formed in the label.
- 14. The removable label of claim 10 wherein the at least one removable segment has at least one extending portion.
- 15. The removable label of claim 10 wherein at least a portion of outermost edges of the at least two segments is nonlinear.
- 16. The removable label of claim 13 wherein at least a portion of the at least one perforation is of uniform length.
- 17. The removable label of claim 13 wherein at least a portion of the at least one perforation has a length of about 0.034 inches.
- 18. The removable label of claim 13 wherein the predetermined path is defined by at least one tie, the at least one tie has a length of about 0.008 inches.
- 19. The removable label of claim 10 wherein removing the at least one removable segment plastically distorts at least a portion of the at least one segment adhered to the container.
- 20. A packaging system comprising:
 - a container;
 - a label attached to the container, the label having a spine and at least one segment disposed adjacent to the spine, the at least one segment being detachably connected to the spine along a predetermined path; and
 - wherein upon the installation of the label on a container, the detachment of the at least one segment from the spine along the predetermined path permits a container to be adjusted between an open position and a closed position.

* * * * *