

(No Model.)

G. A. & A. N. PARNALL.  
ADJUSTABLE ANTI-FRICTION BEARING.

No. 290,601.

Patented Dec. 18, 1883.

Fig. 4.

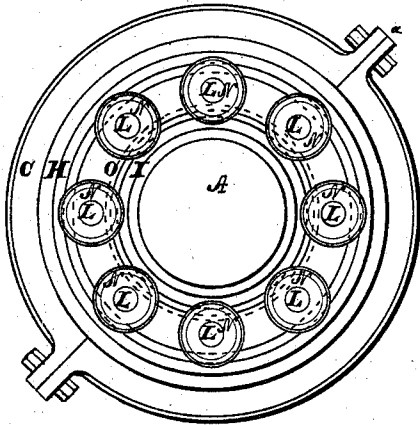

Fig. 3.

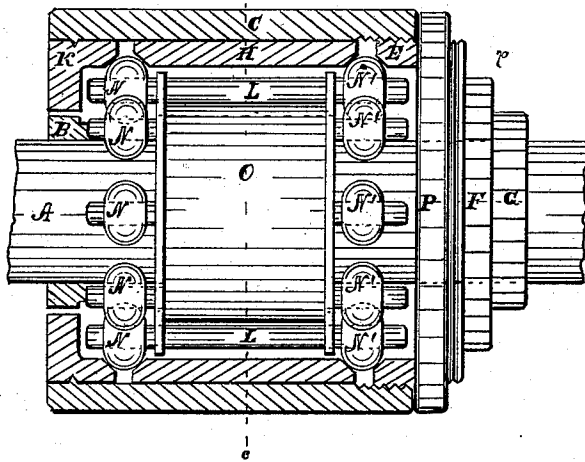

Fig. 1.

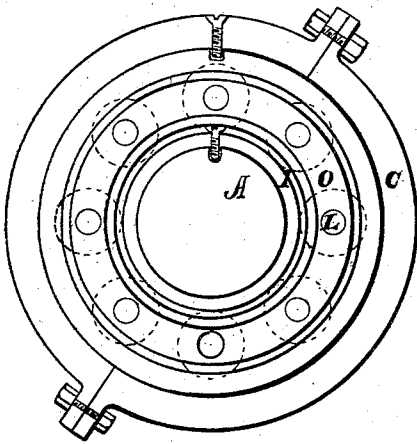
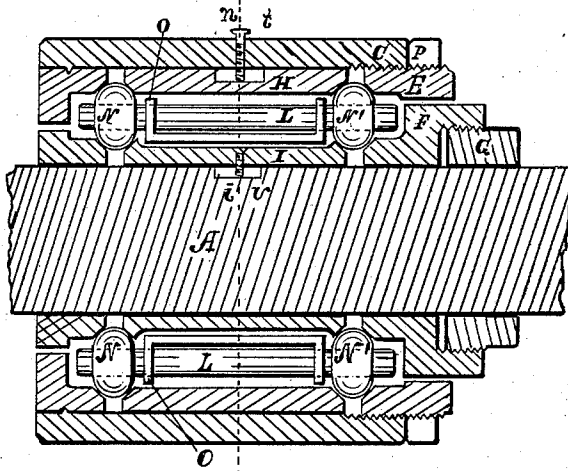

Fig. 2.



WITNESSES:

*W. Harris*  
*Ella C. Harris*

INVENTOR

*George A. Parnall*  
*Albert N. Parnall*

BY

*Geo. M. Amalty*

ATTORNEY

# UNITED STATES PATENT OFFICE.

GEORGE ARTHUR PARNALL AND ALFRED NELSON PARNALL, OF DENVER,  
COLORADO, ASSIGNORS TO WILLIAM E. SCOTT, OF SAME PLACE.

## ADJUSTABLE ANTI-FRICTION BEARING.

SPECIFICATION forming part of Letters Patent No. 290,601, dated December 18, 1883.

Application filed February 2, 1883. (No model.)

*To all whom it may concern:*

Be it known that we, GEORGE ARTHUR PARNALL and ALFRED NELSON PARNALL, citizens of the United States, residing at Denver city, in the county of Arapahoe and State of Colorado, have invented certain new and useful Improvements in Adjustable Anti-Friction Bearings; and we do hereby declare the following to be a full, clear, and exact description of the invention, such as will enable others skilled in the art to which it appertains to make and use the same, reference being had to the accompanying drawings, and to letters or figures of reference marked thereon, which form a part of this specification.

The nature of our invention consists in the construction of anti-friction roller-bearing adjustable journal-boxes, for use in machinery, &c., as will hereinafter be more fully set forth.

In order to enable others skilled in the art to which our invention appertains to make and use the same, reference is had to the annexed drawings, which form a part of this specification, in which—

Figure 1 is an end view with one-half of the parts K and B removed. Fig. 2 is a side view with one-half of the parts C K B H I and section of E removed. Fig. 3 is an end sectional view divided at dotted line *d e*, as shown in Fig. 2. Fig. 4 is a sectional side view.

A represents a shaft, around which is placed a thimble, B, and secured thereto by means of set-screws or keys. Thimble B has one corner beveled to about fifty degrees, a collar, I, having both outside corners beveled to a similar degree, is then placed on the shaft A, at a suitable distance from the thimble B. The collar I is provided with a set-screw or pin, *i*, which projects into a lateral groove, *u*, situated in the shaft A, which allows the collar I to be moved laterally on the shaft. A thimble, F, is then placed on the shaft A, at a suitable distance from the collar I, having one corner beveled to correspond with the beveled corner of the collar I. The thimble F is turned out at *l*, and threaded to receive the collar G, which is also placed on the shaft A, and when screwed forward into the thimble F sufficiently is securely fastened to the shaft A by means of set-screws or keys. A jam-ring, P, having

its inner circumference threaded, is run onto the collar G, locking the parts in place.

The thimbles B and F, with the collars I and G and the jam-ring P, constitute the inside casing of our journal-box. The beveled portions of the parts B, I, and F form grooves or tracks, in which the adjustable rollers travel. Around the collar I is placed a drum, O, turned outward at each end forming collars. Through these collars pass the rollers L L, at one end of which are secured balls N N, which are cast around the rollers L L, or secured thereto by other suitable means. The other end of the rollers have balls N', loosely attached, in order that they may be moved endwise on the shafts or rollers L L. The drum O serves the double purpose of retaining the adjustable rollers at a proper distance apart, and of preventing one end of the rollers from advancing the other. The drum O, having a sufficient number of rollers arranged, is placed around the inside casing, with the balls resting in the grooves or tracks, and is then ready to receive the outside casing, in the construction of which a two-part box, C, is bolted together at *a*, as shown in Figs. 1 and 3, inclosing a ring, K, which is beveled to face against the balls N N, and is held in position by having a V-cone extending around the outside circumference of said ring K, which fits into a corresponding V-groove in the box C. A close-fitting ring, H, is placed inside of the box C, having its two inner corners beveled, said beveled parts facing the balls N and N'. The ring H is provided with a lateral slot, *t*, into which a set-screw or pin, *n*, is projected, which prevents it from revolving, but allows it to be moved laterally. The inner circumference of the box C at *e* is threaded, into which is screwed the ring E, which has its outer circumference threaded to correspond with the threading inside of the box C, and to receive the jam-ring D. When the ring E is screwed forward until all play is taken up, the jam-ring D is screwed up against the box C, which holds the ring E in proper place, completing the outside casing, as well as the entire roller-bearing journal-box.

The balls N and N', as well as the beveled parts forming the grooves or tracks, should

be made of steel, case-hardened iron, or other hard material.

We are aware of the fact that so called "anti-friction bearings" have been constructed by the use of rollers, as well as by the use of loose balls, which, of themselves, rolling against each other, create friction, as well as the lateral friction to which the roller-bearings are necessarily subject. These objections we obviate in our invention, as will be seen by the arrangement of the rollers traveling in grooves in both inner and outer casings, by which there cannot be any lateral friction. Another important feature in our invention is the arrangement of the rollers at a suitable distance apart by use of the drum-ring O, which also prevents one end of the rollers from advancing the other and causing them to cut. As will be seen, any wear occurring to the parts forming the grooves or to the rollers is taken up by screwing forward the rings E and F.

Having thus fully described our invention, what we claim as new, and desire to secure by Letters Patent, is—

1. In a journal-box, the rollers L L, having balls N N permanently affixed thereto, and balls N' N' loosely affixed thereto, substantially as specified.

2. In combination with the journal-box rollers, the drum-ring O, having outward collars provided with receptacles for the rollers, substantially as described.

3. In combination with the journal-box rollers, the inner case consisting of rings B and F, the collars I and G, the jam-ring P, and set-screw *i*, fully as set forth.

4. In combination with the journal-box rollers, the outer casing consisting of the box C, rings K, H, and E, the jam-ring D, the lateral groove *t*, and the set-screw *n*, all substantially as set forth.

5. The combination of an anti-friction roller-bearing adjustable journal-box consisting of an inner and an outer casing inclosing the drum-ring and journal-box rollers, with the shaft A, having slot *u*, fully as set forth, and for the purpose specified.

In testimony whereof we affix our signatures in presence of two witnesses.

GEORGE ARTHUR PARNALL.  
ALFRED NELSON PARNALL.

Witnesses:

FRANK F. DUMKE,  
NELSON PARNALL.