

(19)



(11)

EP 1 638 440 B1

(12)

EUROPEAN PATENT SPECIFICATION

(45) Date of publication and mention of the grant of the patent:
10.08.2011 Bulletin 2011/32

(51) Int Cl.:
A47L 15/44^(2006.01) D06F 39/02^(2006.01)

(21) Application number: **04742907.1**

(86) International application number:
PCT/GB2004/002479

(22) Date of filing: **09.06.2004**

(87) International publication number:
WO 2004/107950 (16.12.2004 Gazette 2004/51)

(54) **AUTOMATIC WASHING MACHINE DETERGENT DISPENSING DEVICE**

AUTOMATISCHER WASCHMITTELDOSIERBEHÄLTER

DISTRIBUTEUR AUTOMATIQUE DE DETERGENT POUR MACHINE A LAVER

(84) Designated Contracting States:
**AT BE BG CH CY CZ DE DK EE ES FI FR GR HU
IE IT LI LU MC NL PL PT RO SE SI SK TR**

• **WIEDEMANN, Ralf,
c/o Reckitt Benckiser Prod. GmbH
67059 Ludwigshafen (DE)**

(30) Priority: **10.06.2003 GB 0313296**

(74) Representative: **Bowers, Craig Malcolm et al
Reckitt Benckiser
Corporate Services Limited
Legal Department - Patents Group
Dansom Lane
Hull
HU8 7DS (GB)**

(43) Date of publication of application:
29.03.2006 Bulletin 2006/13

(73) Proprietor: **Reckitt Benckiser N.V.
2132 WT Hoofddorp (NL)**

(72) Inventors:
• **PREUSCHEN, Judith
c/o Reckitt Benckiser Prod. GmbH
67059 Ludwigshafen (DE)**

(56) References cited:
**DE-A- 4 201 165 DE-A- 19 954 706
US-A- 2 118 299 US-A- 2 698 022
US-A- 2 948 436 US-A- 3 739 942
US-A1- 2002 100 773**

EP 1 638 440 B1

Note: Within nine months of the publication of the mention of the grant of the European patent in the European Patent Bulletin, any person may give notice to the European Patent Office of opposition to that patent, in accordance with the Implementing Regulations. Notice of opposition shall not be deemed to have been filed until the opposition fee has been paid. (Art. 99(1) European Patent Convention).

Description

[0001] The present invention is related to an automatic washing machine detergent dispensing device, particularly for receiving and holding a detergent composition and / or additive and for dispersing said detergent / additive into an automatic washing machine over a plurality of washing cycles.

[0002] In automatic dishwashing machines, the detergent, whether in powder, tablet or gel form, is usually filled manually by the user into the machine, in particular into a detergent holder, before each dishwashing operation.

[0003] This filling process is inconvenient, with the problem of exact metering of the detergent and possible spillage thereof, for powder and gel detergents. Even with detergents in tablet form, wherein the problem of accurate dosing is overcome, there is still the necessity of handling the dishwashing detergent every time a dishwashing cycle is started. This is inconvenient because of the usually corrosive nature of dishwasher detergent compositions.

[0004] A number of devices are known for holding unit doses of a detergent composition or additive, such as detergent tablets, and for dispensing of such unit doses into a machine.

[0005] For example, WO-A-88/06199 discloses a loader for holding and dispensing a washing additive including a receptacle in which there is a plurality of compartments each for receiving washing additive tablets. The compartments are at least partially defined by partitions forming part of a body, which is movable to bring each tablet adjacent to an opening provided in the receptacle. The tablets then pass through the opening to be dispensed, preferably under force of gravity.

[0006] DE 43 44 205 A1 describes a device for dispensing detergent tablets. The dosing device is mounted on the door of a dishwashing machine and loaded with a number of detergent tablets. The dosing device has an ejector for dispensing a single tablet each time the dishwashing machine is used. In a preferred embodiment, the dosing device has a reception shaft for receiving the detergent tablets one after the other, with the ejector being located at the bottom end of the shaft.

[0007] WO 01/07703 discloses a device for the metered release of a detergent composition or additive into a dishwashing machine having a number of separate closed chambers for holding the detergent composition or additive and means for opening the chambers, activated by conditions within the machine.

[0008] US 21, 698, 022 discloses a dispenser for liquid detergents that is operated by a thermal actuated bimetallic strip.

[0009] However, each of these devices suffers from several disadvantages.

[0010] Although the devices solve some of the problems outlined above, the devices have to be complex in order to ensure that the correct detergent / tablet dose

is discharged into the dishwasher cycle at the correct time. This level of complexity is exacerbated by the variation in dishwasher cycle length and temperature present in the many differing automatic dishwasher devices present in the market place. The level of complexity required increases the cost of the devices and reduces the level of benefit provided to the consumer.

[0011] Furthermore, space inside an automatic dishwasher is typically at a premium. Normally the external dimensions of the device are limited by what a consumer will tolerate in the kitchen / utility room. At the same time the consumer has high demands in terms of the amount of houseware which can be washed in a dishwasher cycle. Thus space inside the machine is directed towards maximum accommodation of houseware. This means that there is only a very limited amount of space available for a device within the dishwasher. This is not a problem for a small device such as a dishwasher tablet (which dissolves during the wash anyway) or a small / slender device such as a fragrance emanator but is a problem for the devices described above. This problem is compounded as the high level of complexity increases the size of the device.

[0012] There is still a need to have a simple device which can release the required amount detergent to achieve good cleaning but which is simple and therefore neither costly nor bulky.

[0013] According to a first aspect of the present invention there is provided a portable automatic dishwasher detergent dispensing device comprising a body enclosing a detergent or detergent additive, sufficient for a plurality of wash cycles, the body having an inlet aperture to allow wash liquor to contact the detergent and an outlet aperture to allow the detergent loaded wash liquor to exit the body and means to close the one or both of the apertures at or before the start of the dishwasher rinse cycle and wherein the closing means reacts to a change in temperature during the dishwasher washing cycle and characterised in that the closing means comprises a plurality of thermal bimetal.

[0014] The device according to the invention offers great ease for the consumer as this device provides a multi-dose detergent apparatus which the consumer can place in an automatic dishwasher machine and operate the machine, without further detergent addition, for a plurality of wash cycles.

[0015] The device is able to provides effective dosing of detergent over a plurality of wash cycles. More particularly the device is able to release an appropriate amount of detergent in each dishwasher cycle so that effective washing can be performed without there being any detrimental effect on the rinsing operation of the automatic dishwasher.

[0016] Thermal bimetal typically comprise a structure formed from two different metals / alloys arranged in a layered formation. The combination of different metals / alloys cause the temperature dependent configuration: as most different metals have different temperature ex-

pansion properties the thermal bimetal commonly becomes distorted with changing temperature.

[0017] Thermal bimetals find use in devices where a temperature dependent operation is required, such as in a car direction indicator, where the flow of current through the strip causes the strip to heat up and change from a low temperature configurations to a high temperature configuration and in doing so breaks the circuit to the indicator bulb. Cooling of the strip allows the strip to resume its low temperature configuration and reinstate the circuit. The repeated cooling / heating gives the required on-off indicator auction.

[0018] In the present invention the thermal activator is preferably used to move a plug between a position in which at least one of the inlet and / or outlet apertures is closed (i.e. the plug is within / adjacent to the aperture) to a position in which at least one of the inlet and / or outlet apertures is open (i.e. the plug is distanced from the aperture). Most preferably a thermal bimetal is used to control the operation of a plug in conjunction with the outlet aperture.

[0019] It is recognised that thermal bimetals are divided into conventional thermal bimetals and thermal bimetal snap elements. In the present invention the thermal actuator may comprise a conventional thermal bimetal and / or a thermal bimetal snap element.

[0020] Thermal bimetal snap elements have multiple "snap" temperatures, with the snap temperature referring to the temperature at which the thermal bimetal undergoes a significant change in configuration. There is a higher snap temperature (at which the thermal bimetal snap element distorts from its original configuration into a second configuration) and a lower snap temperature (at which the thermal bimetal snap element distorts back to its original configuration).

[0021] The upper and lower snap temperatures are not equal to one another but are separated. This has the effect that there is a temperature zone at which the thermal bimetal snap element may be at its high temperature configuration even though the temperature of the thermal bimetal snap element is lower than that of the higher snap temperature: the thermal bimetal snap element does not revert to its low temperature configuration until the lower snap temperature is reached.

[0022] This effect is referred to as hysteresis and is described more fully in the journal "Feinwerktechnik, Microtechnik & Messtechnik", 103. Jahrgang 9/95. The effect is also illustrated more clearly with reference to Figure 1 and to the following example.

[0023] Figure 1 is a graph showing orientation of the thermal bimetal snap element (here with preference to distortion distance from a pre-set point (y-axis)) versus temperature (x-axis).

[0024] It can be seen that as the temperature increases the thermal bimetals snap element distorts in a linear fashion until the higher snap temperature (T_o) is reached. At this point the distortion of the thermal bimetal snap element jumps to the high temperature configuration.

With further increasing temperature the thermal bimetal snap element again distorts in a linear fashion.

[0025] As the temperature of the thermal bimetal snap element is decreased (starting from above the higher snap temperature) the reverse occurs. The thermal bimetal snap element distorts in a linear fashion until the lower snap temperature (T_u) is reached. At this point the thermal bimetal snap element jumps to the low temperature configuration. With further decreasing temperatures the thermal bimetal snap element again distorts in a linear fashion.

[0026] Thus a hysteresis effect is observed between T_o and T_u .

[0027] Preferably the thermal bimetal snap elements used in the present invention is selected so as to have a lower and a higher snap temperature which is suited to the operation of the device in an automatic dishwashing machine.

[0028] Where a single thermal bimetal snap element is used to move the plug, the thermal bimetal snap element preferably has a higher snap temperature of between 35 to 45°C, more preferably between 38 to 42°C and most preferably about 40°C. The thermal bimetal snap element preferably has a lower snap temperature of about 20 to 30°C, more preferably between 23 to 27°C and most preferably about 25°C. Most preferable the difference between the snap temperatures is about 15°C.

[0029] This is made more clear with reference to Figure 2 which shows a typical temperature / time profile of an automatic dishwashing machine.

[0030] Figure 2 is a graph showing the temperature of the inside of a typical dishwasher machine (y-axis) versus time (x-axis). Labels which identify portions of the wash cycle (wash cycles and rinse cycles) are also shown.

[0031] It can be seen that the dishwasher temperature starts from a low starting point of 15°C to 25°C. In operation as the main wash cycle is carried out the temperature increased to a maximum plateau of about 50°C to 75°C (defined by the chosen wash program). There are commonly one or more additional intermediate wash cycles at lower temperature, before the temperature decreases back down to around 30°C to 35°C in between the wash and the rinse cycle. As the rinse cycles are carried out the temperature inside the machine increases to a maximum plateau of about 70°C before dropping down to around 20°C.

[0032] A thermal bimetal snap element which displays the preferred higher and lower snap temperature described above may be used to close at least one of the inlet and / or outlet apertures as the temperature reaches 40°C yet will not re-open the aperture until the temperature drops to 25°C.

[0033] Hence dishwasher liquor may become loaded with detergent until a temperature of 40°C is reached. This allows sufficient detergent to enter the dishwasher wash liquor to meet the washing requirements during the wash cycles.

[0034] Above 40°C at least one of the inlet and / or

outlet apertures of the device is closed such that no more detergent is loaded into the wash liquor. Even though the temperature of the machine drops between the wash cycle and the rinse cycle the temperature does not drop to the lower snap temperature, with the effect that the closed aperture does not re-open until the dishwasher cycle is finished and the machine is allowed to cool back to ambient temperature. Therefore the rinse cycles operate efficiently and perform effectively rinsing of the dishwasher contents without being hindered by further detergent addition.

[0035] The thermal bimetal snap element may be in the form of a strip. In this case generally a first portion of the strip is attached to / lases with the device (such as with a portion of the body) and a second portion of the strip is attached to / lases with the plug. Distortion of the strip causes movement of the plug relative to the device / aperture causing the opening / closing of the aperture.

[0036] The thermal bimetal snap element may be in the form of a 2-dimensional shape (such as a square or circle / disc). Hereby, it is understood that in at least one of the configurations of the thermal bimetal snap element (i.e. above and / or below the lower / upper snap temperatures) the thermal bimetal snap element may actually comprise a 3-dimensional shape (such as a dome / cone). Indeed the seemingly 2-dimensional shape may in reality comprise a 3-dimensional form in both high and low temperature configurations with alteration of temperature causing the 3-dimensional shape to become inverted.

[0037] In this case the thermal bimetal snap element need not be rigidly attached to a portion of the device but instead retained herein such that a periphery of the thermal bimetal snap element may interact with the plug and the device, as the thermal bimetal snap element alters its 3-dimensional state, moving the plug relative to the device / aperture.

[0038] As an example the device may include a plate on which the strip is mounted adjacent to the plug. The mounting means may include a rod extending from the plug which intersects the thermal bimetal snap element by a suitable aperture. Said rod may have a terminal flange to retain the thermal bimetal snap element thereon / interact with the thermal bimetal snap element. Activation of the thermal bimetal snap element, by crossing the higher / lower snap temperature causes the thermal bimetal snap element to form a 3-dimensional shape / invert the pre-existing 3-dimensional shape. This causes interaction of the thermal bimetal snap element with the plug / flange altering the position of the plug.

[0039] Optionally the rod comprises a frame mounted thereon between the portion of the rod which intersects the thermal bimetal snap element and the plug.

[0040] In an alternative arrangement the alteration of the shape of the thermal bimetal may in itself control the opening of at least one of the inlet and / or outlet aperture.

[0041] In this regard the thermal bimetal snap element may be mounted within the devices such that it creates

a plug around at least one of the inlet and / or outlet aperture at its high temperature configuration. Namely the periphery of the thermal bimetal snap element may engage the area adjacent to the aperture in the high temperature configuration, forming a three-dimensional structure thereupon, thus blocking at least one aperture.

[0042] In contrast to thermal bimetal snap elements conventional thermal bimetal do not display a hysteresis effect. Instead conventional thermal bimetal display a largely linear distortion over a specified temperature range.

[0043] In the present invention the thermal actuator may comprise a conventional thermal bimetal which may be used to move a plug into engagement with at least one of the inlet and / or outlet apertures. Alternatively the conventional thermal bimetal may engage the aperture itself providing a closing effect.

[0044] Where the conventional thermal bimetal moves a plug into engagement with at least one of the inlet and / or outlet apertures it is preferably arranged within the device so that a portion of the conventional thermal bimetal engages a portion of the body of the device and a portion of the conventional thermal bimetal engages a portion of the plug.

[0045] The conventional thermal bimetal may comprise a spiral shape. Such a shape is recognised to exaggerate the effect of temperature upon the amount of displacement of the conventional thermal bimetal.

[0046] In order to attempt to provide a hysteresis effect using a conventional thermal bimetal the plug may have a plurality of engagement points for the conventional thermal bimetal. Preferably the points are distanced from one another.

[0047] As an example the plug may comprise a linear incision, the termini of which are used to engage a portion of a conventional thermal bimetal. The space between the termini provides a delay during which movement of the conventional thermal bimetal with changing temperature does not move the plug.

[0048] A plurality of thermal bimetal may be used to move the plug / control the opening of at least one of the inlet / outlet apertures.

[0049] In this embodiment the device preferably comprises a primary thermal bimetal which interacts with the plug and a secondary thermal bimetal which has an effect on the operation of the primary thermal bimetal / opening of at least one of the inlet / outlet apertures.

[0050] The primary thermal bimetal preferably comprises a conventional thermal bimetal strip which has an activation temperature of about 30°C. Thus at temperatures of above 30°C the plug may be opened to allow wash liquor to contact the detergent. (see octagon picture, strip is up)

[0051] The secondary thermal bimetal preferably comprises a thermal bimetal snap element having a lower and a higher snap temperature as outlined above.

[0052] The secondary thermal bimetal may be used to block the activity of the primary thermal bimetal. This may

be achieved by physical contact between the primary and secondary thermal bimetals or by physical contact between the plug and the secondary thermal bimetal.

[0053] Alternatively the secondary thermal bimetal may liase with a secondary plug which is used to block at least one of the inlet / outlet apertures.

[0054] For the first option the primary thermal bimetal opens at least one of the inlet / outlet apertures at about 30°C, thus allowing liquor to enter and flow through the device, releasing detergent into the wash liquor in the machine.

[0055] Ordinarily the primary thermal bimetal would close the aperture as the temperature drops below 30°C near the end of the wash cycle. Additionally with no thermal bimetal present the primary thermal bimetal would re-open the aperture as the temperature of the dishwasher machine climbed again during the rinse cycle, thus causing detrimental release of dishwasher detergent.

[0056] The presence of the secondary thermal bimetal prevents the re-opening of the aperture during the rinse cycle.

[0057] This is achieved by the secondary thermal bimetal providing a one-way blocking function. Namely the secondary thermal bimetal is arranged in the device such that in its high temperature configuration it forms a block to the movement of the primary thermal bimetal / plug. Most particularly secondary thermal bimetal preferably only acts as a block on the activation of the primary thermal bimetal with increasing temperature (especially as the temperature increases for the second time in the dishwasher cycle) but allows the activation associated with decreasing temperature to occur.

[0058] Thus as the temperature in the wash cycle changes during the wash cycle the following events occur:

a) As the temperature increases above 30°C the primary thermal bimetal is activated opening the aperture.

b) As the temperature increases above 40°C the secondary thermal bimetal is activated blocking the movement of the primary thermal bimetal / plug.

c) As the temperature decreases below 30°C the primary thermal bimetal is activated closing the aperture. The closing occurs as the secondary thermal bimetal does not provide a blocking function for closing of the aperture.

d) As the temperature increases for the second time above 30°C the primary thermal bimetal is activated. However, activation of the primary thermal bimetal is prevented by the presence of the secondary thermal bimetal, in the activation pathway of the primary thermal bimetal / plug.

e) As the temperature decreases below 25°C the

secondary thermal bimetal is activated returning to its low temperature configuration. Thus the primary thermal bimetal may be activated for the next wash cycle.

[0059] For the second option the primary thermal bimetal opens at least one of the inlet / outlet apertures at about 30°C, thus allowing liquor to enter and flow through the device, releasing detergent into the machine.

[0060] Ordinarily the primary thermal bimetal would close the aperture as the temperature drops below 30°C near the end of the wash cycle and re-open the aperture during the rinse cycle (as described above).

[0061] The presence of the secondary thermal bimetal prevents the re-opening of the aperture during the rinse cycle. This is achieved by the secondary thermal bimetal blocking the aperture with a second plug. Namely the secondary thermal bimetal is arranged in the device such that in its high temperature configuration it moves a second plug into engagement with the aperture.

[0062] Thus, as the temperature in the wash cycle changes during the wash cycle the following events occur:

a) As the temperature increases above 30°C the primary thermal bimetal is activated opening the aperture.

b) As the temperature increases above 40°C the secondary thermal bimetal is activated moving the second plug into engagement with the aperture.

c) As the temperature decreases below 30°C the primary thermal bimetal is activated closing the aperture. However, the primary plug is only forced into contact with the secondary plug.

d) As the temperature increases for the second time above 30°C the primary thermal bimetal is activated. However, activation of the primary thermal bimetal only serves to move the primary plug away from contact with the secondary plug.

e) As the temperature decreases below 30°C for the second time the primary thermal bimetal is activated closing the aperture. However, the primary plug is only forced into contact with the secondary plug.

f) As the temperature decreases below 25°C the secondary thermal bimetal is activated returning to its low temperature configuration. Thus the primary thermal bimetal may close the aperture by bringing the primary plug into engagement therewith.

[0063] The thermal actuator may comprise a shape memory alloy or a wax actuator. Both of these elements are recognised to undergo temperature induced deformation and so may be used to control the opening of at

least one of the inlet and / or outlet apertures by movement of a plug or by engagement thereof.

[0064] Optionally the device may comprise a auxiliary chamber disposed adjacent the main body of the device external to the inlet and / outlet apertures. This finds utility in further enhancing the discharge characteristics of the device.

[0065] As an example, two manifestations of the device having a auxiliary chamber are described below.

[0066] In a first manifestation the device is intended to be used where the incoming water temperature / the ambient temperature of the locus of the automatic dishwasher is low. Both of these situations may occur in the winter months of countries with temperate climates (e.g. Northern Europe, North America). Here the temperature of the incoming water/ambient temperature can easily be lower than the lower snap temperature of the snap elements described above. Thus there is a significant risk that the lower snap temperature could be reached between the wash cycles and the rinse cycles with the obvious detrimental effects for the rinse cycle (release of detergent).

[0067] In this manifestation the auxiliary chamber preferably comprises a thermal activator which associates with an access opening the thermal activator comprising, a thermal bimetal. Most preferably the thermal bimetal is in the form of a strip. The strip is preferably arranged relative to the auxiliary chamber such that in its first orientation the access opening is closed either by the strip itself or by a plug linked thereto, and in a second orientation the access opening is open. Most preferably the thermal bimetal is such that it is arranged in its first orientation at temperatures at or below 30°C. Most preferably the thermal bimetal is such that it is arranged in its second orientation at temperatures above 30°C.

[0068] In a second manifestation the device is intended to be used in the dispense of a liquid/powder detergent formulation. Here, it will be appreciated that simple opening/closing of the inlet/outlet apertures will not give the correct level of control of discharge of the detergent from the device as the detergent being fluid will simply be able to flow out of one or both of these apertures when opened. In this manifestation the purpose of the auxiliary chamber is to allow a determined dose of detergent to be dispensed into a wash cycle over a plurality of wash cycles.

[0069] In this manifestation the auxiliary chamber preferably comprises an access opening. Generally the auxiliary chamber has a closure means for the access opening which operates such that the access opening is open as the main body outlet is closed and vice-versa. Thus, in the latter arrangement, filling of the auxiliary chamber with the determined volume of detergent may occur without discharge from the device. In the former arrangement, discharge of the detergent into the wash liquor may occur without re-filling of the auxiliary chamber.

[0070] Most preferably a linkage is disposed between the auxiliary closure means and the main body closure means to ensure that the synchronised opening/closing of the auxiliary chamber/main body outlet is as described

in the above paragraph.

[0071] The access opening of the auxiliary chamber may associate with its own bespoke thermal activator. Alternatively a single activator/activator system may be used, in conjunctions with the linkage to control the opening of both the auxiliary chamber access opening and the outlet of the main body.

[0072] The thermal activator(s) preferably comprises a thermal bimetal snap element or a thermal bimetal/thermal bimetal snap element combination as described above. For clarity, where the auxiliary chamber has its own bespoke thermal activator, this shall be referred to as the auxiliary thermal activator (as opposed to the main body thermal activator).

[0073] The thermal activator/each of the thermal activators preferably operates with a lower snap temperature of around 25°C and a higher snap temperature of around 40°C.

[0074] Thus in use the device functions as follows (described with reference to a device comprising a thermal activator for the outlet of the main body as well as for the access opening of the auxiliary chamber. It will be appreciated that the description is also applicable to a device having a single thermal activator).

a) The main body thermal activator and the auxiliary chamber thermal activator are in their low temperature formation: the outlet from the main body is opened and the access opening of the auxiliary chamber is closed. The auxiliary chamber of the device is filled with liquid/powder detergent.

b) The user places the device inside an automatic dishwasher.

c) As the temperature increases above 40°C the main body thermal activator and the auxiliary chamber thermal activator change to their high temperature formation: the outlet from the main body is closed and the access opening of the auxiliary chamber is opened. The auxiliary chamber of the device is emptied into the wash liquor/washed out by the wash liquor.

d) As the temperature decreases between the wash cycle(s) and the rinse cycle(s) the decrease is not sufficiently low to cause any alteration in the thermal activators of the auxiliary/main body of the device. Both remain in their high temperature formations.

e) As the temperature increases for the second time no further change occurs to the thermal activators of the main body/auxiliary chamber.

[0075] Most preferably the thermal bimetal snap elements (for both the auxiliary chamber and the main body) are in the form of domes/cones as described above. Generally the linkage between the two snap elements is

in the form of a rod.

[0076] Optionally the device comprises a second linkage accessible by a user from the exterior of the device. Most preferably the primary and secondary linkage are in the form of a single element (preferably a rod). Actuation of the second linkage is preferably effected in a pushing/pulling motion.

[0077] Preferably a user activates the linkage (e.g. by depression/operation of a suitable knob/button) to cause simultaneous activation of the main body thermal activator (and hence affects the closure extent of the main body outlet) and the auxiliary chamber thermal activator (and hence affects the closure extent of the auxiliary chamber access opening). Thus the device may be described as being "semi-automatic".

[0078] Clearly since the device is for dispense of a liquid/powder detergent formulation it is preferred that the device is positioned in the machine such that the detergent can flow under gravity from the main body of the device into the auxiliary chamber.

[0079] The volume of the auxiliary chamber may be altered to suit the exact detergent being used. However, generally the volume of the auxiliary chamber is around 20-30cm³.

[0080] The liquid/powder detergent may be a "2-in-1" or a "3-in-1" automatic dishwasher detergent, It will be appreciated that the detergent may comprise any of the features of the solid detergent described below, with the only difference being the physical form of the detergent. For liquid detergent formulations it is preferred that the viscosity of the liquid is less than 30,000mPas and more preferably around 10,000mPas. For powder formulations it is preferred that the average particle size is less than 1mm and more preferably around 0.5mm.

[0081] The main body inlet aperture may have a collecting funnel associated herewith which collects wash liquor and directs it towards the inlet aperture. Most preferably the collecting funnel, and inlet aperture are arranged so that the only way in which wash liquor can enter the inlet aperture is via the collecting funnel. This may be achieved by having the dispensing portion of the collecting funnel, abutting against the internal periphery of the inlet apertures.

[0082] Preferably the collecting funnel has a drainage opening in its collecting portion. When present the drainage opening ensures that the level of wash liquor in the collecting portion of the funnel does not exceed a certain pre-determined level. If it is assumed that the collecting funnel is filled up to the drainage aperture for the duration of the wash and / or rinse cycles then the amount of wash liquor discharge from the collecting funnel into the channel will be largely constant per wash cycles.

[0083] The device is most preferably formed of a water-resistant material. Most preferably the device comprises a water insoluble material. Preferred materials include glass, ceramic, metal and plastics materials such as an alkene polymer, e.g. polypropylene. Plastics materials are most preferred due to their resilience and low cost

(material and manufacturing costs).

[0084] Generally the main body of the device comprises a channel which is in communication with the inlet aperture. Preferably the channel has the detergent disposed therein, wherein (for non-liquid detergent formulations) the detergent comprises a bar which completely fills at least a portion of the channel across the entire bore of the channel.

[0085] In this arrangement it has been found that the device is able to provide a uniform / equal amount of detergent in each dishwasher cycle for an individual dishwasher using the same washing program in consecutive wash cycles. (Uniform discharge of liquid/powder detergent is achieved using the auxiliary chamber as described above).

[0086] Without wishing to be bound by theory it is postulated that the uniform / predictable release property arises due to the arrangement of the detergent bar within the channel. With such an arrangement a portion of the detergent bar contacts the channel and is thus protected by the channel, i.e. is not exposed to the wash liquor even when both the inlet and outlet apertures are open. A second portion of the detergent bar, which extends across the bore of the channel, is exposed to the wash liquor. The surface area of this second exposed portion is determined by the bore of the channel.

[0087] In use in a washing machine the detergent is dispensed and thus the portion of the detergent exposed to the wash liquor "retreats" along the channel. Thus most preferably the channel has a uniform bore, in terms of the cross sectional area of the bore, along its length / at least along the portion filled by the detergent bar. This allows the surface area of the exposed portion of the detergent bar to remain constant as the exposed portion of the bar retreats along the channel. In this way any problems of decreasing / altering surface area, such as would be experience with a simple 3-dimensional block, the surface area of which decreases as the block is dispersed, are overcome.

[0088] Generally the channel is a tube. Most preferably the tube is cylindrical, although any cross-sectional shape is possible (e.g. regular / irregular polygon such as a triangle, square, rectangle, pentagon, hexagon). The tube may include a smaller tube disposed along a portion of its length. Such a tube may provide additional structural integrity for the detergent bar. Where a second tube is present it is preferred that the second tube has a uniform cross section along its length / the length of the detergent bar, thus the surface area of the detergent bar exposed to the wash liquor is constant as the detergent bar retreats along the channel.

[0089] Typically the channel is completely filled along a portion of its length across the entire cross-section thereof by the detergent bar. Thus a portion of the detergent bar is in contact with the interior of the channel and is thus protected by the channel, i.e. not exposed to wash liquor. A second portion of the detergent bar, which extends across the bore of the channel, is exposed to the

wash liquor.

[0090] Most preferably the exposed portion of the detergent bar comprises a planar surface. Generally the planar surface is perpendicular to the periphery of the channel.

[0091] Most preferably the channel only has one open end which communicates with the inlet aperture to allow wash liquor to contact the detergent bar. Thus the body may comprise a form similar to a drinking glass.

[0092] In an alternative arrangement the channel may comprise a tube with both ends open to wash liquor (via an inlet aperture) with the detergent bar disposed at a central portion of the tube.

[0093] The detergent bar most preferably comprises an automatic dishwasher detergent. Preferred examples of which include conventional detergents, and the "2-in-1" and "3-in-1" variants. Most preferably the detergent bar comprises a solid so that the rigours of the movement of the washing machine liquor will not cause the entire detergent bar to be dispensed / discharged in the first washing cycle. In the context of the present invention the term solid can be taken to include solidified gels as well as conventional solid materials (such as compressed particulate materials and solidified molten / cross-linked materials).

[0094] The detergent bar contains sufficient detergent for a plurality of dishwasher wash cycles. Preferably the detergent bar contains sufficient detergent for between 3 to 20 dishwasher wash cycles, more preferably from 5 to 12 dishwasher wash cycles.

[0095] The detergent formulation typically comprises one or more of the following components; builder, co-builder, surfactant, bleach, bleach activator, bleach catalyst, enzyme, polymer, dye, pigment, fragrance, water and organic solvent.

[0096] Optionally the detergent bar comprises a detergent additive. It will be appreciated that a detergent additive, when compared to a detergent, may be required during a different section of the dishwasher wash cycle (e. g. such as the rinse cycle for a rinse aid detergent additive). Thus in accordance with a second aspect of the present invention there is provided a portable automatic dishwasher detergent additive dispensing device comprising a body enclosing a detergent additive, sufficient for a plurality of wash cycles, the body having an inlet aperture to allow wash liquor to contact the detergent and an outlet aperture to allow the detergent loaded wash liquor to exit the body and means to open one or both of the apertures at or after the start of the dishwasher rinse cycle.

The device according to the invention offers great the same ease for the consumer as the device in accordance with the first aspect of the invention. However, in this case it allows the release of a detergent additive over a plurality of wash cycles where the detergent additive is required for the rinse cycle rather than the main wash cycle. Thus the device is able to release an appropriate amount of detergent additive in each dishwasher rinse

cycle so that effective rinsing can be performed without there being any detrimental effect on the washing operation of the automatic dishwasher.

[0097] Preferred detergent additives include rinse aids, antispotting composition (e.g. such as that sold under the trade name of Jet-Dry) and also glass corrosion prevention compositions such as those containing zinc (in the form of a glass, glass granulate, or other soluble form).

[0098] In the case of zinc the delay of the release until the rinse cycle can give beneficial washing effects as zinc is recognised to detrimentally effect bleaching in the wash cycle causing poor stain (especially tea stain) removal.

[0099] It will be understood that the features of the first aspect of the invention shall apply *mutatis mutandis* to the second aspect of the invention. Clearly the emphasis / distinction of release in the rinse cycle rather than the wash cycle will be made.

[0100] According to a third aspect of the present invention there is provided the use of an automatic washing machine detergent dispensing device in accordance with the first of the invention.

[0101] Most preferably the device is used where the devices can easily be accessed and nicely visible. The front part of the upper rack is preferred.

[0102] The invention is now further described with reference to the following Figures in which: -

[0103] Figures 3(a), 3(b) and 3(c) are side cross-sectional views of a detergent dispensing device in accordance with the present invention wherein only a single thermal bimetal is shown for clarity;

[0104] Figures 4 (a), 4(b) and 4(c) are side cross-sectional views of an alternative, detergent dispensing device in accordance with the present invention wherein only a single thermal bimetal is shown for clarity;

[0105] Figure 5 shows a temperature / time profile of a dishwasher cycle;

[0106] Figures 6(a), 6(b), 6(c), 6(d) and 6(e) are side cross-sectional views of a fourth embodiment of a detergent dispensing device in accordance with the present invention;

[0107] Figure ,7 shows a temperature / time profile of a dishwasher cycle and how this effects the embodiment illustrated in Figures 7(a) to 7(e); and

[0108] Figures 8(a) and 8(b) are side cross-sectional views of a fifth embodiment of a detergent dispensing device in accordance with the present invention.

[0109] Figure 3a shows a detergent dispensing device 1. The device 1 comprises a. detergent bar 2 which is disposed within a body 3. The body 3, as illustrated, is based on a sphere with a plate section 4.

[0110] The body 3 has a wash liquor inlet 5, which allows the wash liquor to contact the detergent bar 2 and thus become loaded with detergent. The body 3 has a wash liquor outlet 6 which allows the detergent loaded wash liquor to exit from the body 3. The wash liquor inlet 5 and wash liquor outlet 6 are formed in the plate 4 of

the body 3.

[0111] The body 3 has a dispensing control means which controls the opening of the inlet 5 and outlet 6 apertures. This means is mounted on the plate 4. The means comprises two plugs 7a, 7b which, liase / engage with the inlet aperture 5 and the outlet aperture 6 respectively. As shown the plugs 7a, 7b comprise cylindrical rods, although it will be appreciated that one or both plugs 7a,7b may have alternate forms to co-operate with their respective aperture 5,6.

[0112] The plate 4 has a central aperture 8. The central aperture 8 is equally distanced between the inlet aperture 5 and the outlet aperture 6.

[0113] The dispensing control means further comprises a rod 9, which can move upwards and downwards in the central aperture 8 relative to the plate 4. The rod 9 has an upper terminal flange 10 and a lower terminal flange 11.

[0114] The upper terminal flange 10 is circular and has a diameter which is slightly larger than the central aperture 8 to prevent the rod 9 from dropping there through.

[0115] The lower terminal flange 11 is also circular and has a radius such that the flange 11 extends as far as the outlet aperture 6 and the inlet aperture 5. The lower terminal flange 11 provides support for the plugs 7a,7b.

[0116] Disposed around the rod 9 between the plate 4 and the upper flange 10 is a circular thermal bimetal snap element 12. The thermal bimetal snap element 12, in reaction to changing temperature, controls the position of the dispensing controls means. This is explained below and is more clearly illustrated with additional reference to Figures 3b and 3c.

[0117] Figure 3a illustrates the dispensing control means at a temperature below the upper snap temperature (40°C) of the thermal bimetal snap element 12. Below this temperature the thermal bimetal snap element 12 comprises a truncated dome orientated such that the tip of the dome abuts against the plate 4 and the periphery of the dome extends away from the plate 4. Thus the upper flange 10 is proximal to the plate 4; this means that the inlet aperture 5 and outlet aperture 6 are both open.

[0118] Figure 3b illustrates the dispensing control means at a temperature above the upper snap temperature (40°C) of the thermal bimetal snap element 12. Above this temperature the thermal bimetal snap element 12 comprises a truncated dome orientated such that the tip of the dome abuts against the upper flange 10 and the periphery of the dome abuts against the plate 4. In this orientation the upper flange 10 is distanced from the plate 4, additionally the lower flange 11 and plugs 7a,7b are brought towards the plate 4 with the effect that the plugs 7a, 7b engage the inlet aperture 5 and the outlet aperture 6 respectively. Thus the inlet 5 and outlet 6 apertures are closed.

[0119] Figure 3c illustrates the dispensing control means at a temperature below the lower snap temperature (25°C) of the thermal bimetal snap element 12 (this orientation is the same as that shown in Figure 3a).

[0120] To bring the operation of the thermal bimetal snap element 12 and its snap temperatures in to context reference is made to Figure 5. Figure 5 shows the typical temperature/time profile of a dishwasher cycle.

5 Figure 5 also includes marking for the lower 13 (25°C) and upper snap point 14 (40°C) of the thermal bimetal snap element 12. Thus it can be seen that the dishwasher liquor may become loaded with detergent until a temperature of 40°C is reached, this allows sufficient detergent
10 to enter the dishwasher wash liquor to meet the washing requirements during the wash cycles. Above 40°C at least one of the inlet 5 and / or outlet 6 apertures of the device 1 is closed such that no more detergent is loaded
15 into the wash liquor. This allows the rinse cycles to operate effectively and perform effectively rinsing of the dishwasher contents as although the temperature of the machine drops in between the wash and the rinse cycle it does not drop to the lower snap temperature, thus the closed aperture does not re-open until the rinse cycle is
20 finished.

[0121] Figures 4(a) to 4(c) show an alternative embodiment of the device of Figures 3(a) to 3(c). In these Figures the principle of operation of the device is identical. The distinction is that the thermal bimetal snap element
25 12 itself provides a closing action for the inlet aperture 5 and the outlet aperture 6 as the temperature increases above the upper snap temperature.

[0122] This is achieved by the thermal bimetal snap element 12 being mounted on the rod 9 with the rod 9 being fixedly attached within the aperture 8. Thus a change in the configuration of the thermal bimetal snap element 12 does not have an effect on the position of the rod 9. Instead the change in configuration only affects the position of the thermal bimetal snap element 12 itself.
30 In this case above the higher snap temperature the periphery of the truncated cone is brought into contact with the plate 4, thus sealing both the inlet aperture 5 and the outlet aperture 6.

[0123] Figures 6(a) to 6(e) show an alternative embodiment of the device of Figures 4(a) to 4(c). In these Figures the principle of operation of the device is similar: the thermal bimetal snap element 12 itself provides a closing action for the inlet aperture 5 and the outlet aperture 6
35 as the temperature increases above the upper snap temperature.

[0124] Additionally the device 1 comprises an auxiliary chamber. The auxiliary chamber is formed from an extension of the side walls 20 of the device. The side walls 20 have an adjoining/connecting section 21 which together with the extensions 20 creates an enclosed chamber.
40

[0125] The auxiliary chamber has an access opening 22. The access opening has an associated thermal bimetal 23. The orientation of the thermal bimetal 23 alters with temperature and serves to close the access opening 22 at low temperature (<30°C) and open the access opening 22 at higher temperature (>30°C).
45

[0126] The operation of this embodiment of the device is more clearly explained with reference to Figure 8.

[0127] Figure 8 includes markings (a circle (room temperature), an octagon (30°C), a star (40°C) and a polygon (>25°C or <25°C)).

[0128] Thus it can be seen at room temperature the access opening 22 of the auxiliary chamber is closed (regardless of the orientation of the snap element 12) such that no detergent is loaded into the wash liquor. As the temperature rises above 25°C the access opening 22 of the auxiliary chamber is opened and the wash liquor may become loaded with detergent until a temperature of 40°C is reached (the upper snap temperature of the snap element 12). This allows sufficient detergent to enter the dishwasher wash liquor to meet the washing requirements during the wash cycles. Above 40°C the snap element 12 is closed such that no more detergent is loaded into the wash liquor. And although, the temperature of the machine drops in between the wash and the rinse cycle to less than 25°C (below the lower snap temperatures of the snap element 12) this temperature drop is not sufficient to trigger discharge of the detergent into the rinse cycle as the access opening of the -re-dosing chamber 22 is blocked by the thermal bimetal 23.

[0129] Figures 6(a) and 8(b) show a yet further alternative embodiment of the device. In this embodiment the detergent 2 is fluid: either in the form of a liquid or a powder.

[0130] In these Figures the principle of operation of the device is similar: the thermal bimetal snap element 12 itself provides a closing action for the inlet aperture 5 and the outlet aperture 6 as the temperature increases above the upper snap temperature.

[0131] Additionally the device 1 comprises an auxiliary chamber. The auxiliary chamber is formed from an extension of the side walls 20 of the device. The side walls 20 have an adjoining/connecting section 21 which together with the extensions 20 creates an enclosed chamber.

[0132] The auxiliary chamber has an access opening 22. The access opening 22 has an associated thermal bimetal snap elements 24 disposed adjacent the exterior thereof. The orientation of the thermal bimetal snap element 24 similarly alters with temperature and serves to close and open the access opening 22.

[0133] In this embodiment the rod 9 extends between both the thermal bimetal snap elements 12 and 24.

[0134] The rod 9 has a flange 10 which co-operates with the thermal bimetal snap element 12. Further the rod 9 has a secondary flange 25 which co-operates with the thermal bimetal snap element 24.

[0135] The rod 9 terminates at its lower end against a reinforcement plate 26 which is disposed external to the auxiliary chamber. The rod 9 terminates at its upper end about the flange 10.

[0136] Figure 8(a) shows the device after it has been used in a wash cycle. Both of the thermal snap elements 12 and 24 are in their low temperature orientation. In this orientation the outlet 6 and the inlet 5 are opened as the access opening 22 is closed. Thus the auxiliary chamber fills with liquid/powder detergent 2. Figure 9(b) shows

the device after the knob has been depressed.

[0137] The user can then place the device 1 inside an automatic dishwasher.

[0138] As the dishwasher operates and the temperature increases above 40°C the thermal bimetal snap elements 12 and 24 change to their high temperature formation. This has the effect that the device 1 alters to the orientation shown in Figure 9(b). Thus the inlet 5 and the outlet 6 are closed and the access opening 22 of the auxiliary chamber is opened. The detergent content 2 of the auxiliary chamber of the device is emptied into the wash liquor.

[0139] As the temperature decreases between the wash cycle(s) and the rinse cycle(s) the decrease is not sufficiently low to cause any alteration in the thermal activators 12 and 24 of the device. Both remain in their high temperature formations: no further detergent is dispensed.

At the end of the wash cycle / after the wash cycle has finished thermal activators 12 and 24 revert to their low temperature formation.

[0140] It will be appreciated that the invention is not intended to be overly limited by reference to the Figures 3 to 5, 6, & 8.

Claims

1. A portable automatic dishwasher detergent dispensing device (1) comprising a body (3) enclosing a detergent (2) or detergent additive, sufficient for a plurality of wash cycles, the body having an inlet (5) aperture to allow wash liquor to contact the detergent and an outlet aperture (6) to allow the detergent (2) loaded wash liquor to exit the body and means to close the one or both of the apertures at or before the start of the dishwasher rinse cycle and wherein the closing means reacts to a change in temperature during the dishwasher washing cycle and **characterised in that** the closing means comprises a plurality of thermal bimetal.
2. A device according to claim 1, wherein the device (1) comprises a primary thermal bimetal (12) which affects the interaction of a plug (7a, 7b) with the inlet (5) outlet (6) aperture and a secondary thermal bimetal (24) which affects the operation of the primary thermal bimetal (12).
3. A device according to claim 2, wherein the primary thermal bimetal (12) is a conventional thermal bimetal having an activation temperature of about 40°C.
4. A device according to claim 2 or 3, wherein the secondary thermal bimetal (24) comprises a thermal bimetallic snap element having a higher snap temperature of about 40°C and a lower snap temperature of about 25°C.

5. The use of an automatic washing machine detergent dispensing device (1) in accordance with any one of claims 1 to 4.

Patentansprüche

1. Tragbare automatische Reinigungsmittel-Abgabevorrichtung (1) für Geschirrspüler, umfassend einen Körper (3), der ein Reinigungsmittel (2) oder einen Reinigungsmittelzusatz umschließt, ausreichend für eine Mehrzahl von Waschzyklen, wobei der Körper eine Einlassöffnung (5), damit Waschlauge mit dem Reinigungsmittel in Kontakt kommen kann, und eine Auslassöffnung (6), damit das Reinigungsmittel (2), das mit der Waschlauge beladen ist, aus dem Körper austreten kann, und Mittel umfasst, die nahe der einen oder beiden der Öffnungen bei oder vor Beginn des Spülzyklus des Geschirrspülers angeordnet sind, und wobei das Verschlussmittel auf eine Temperaturveränderung während des Spülzyklus des Geschirrspülers reagiert, und **dadurch gekennzeichnet, dass** das Verschlussmittel eine Mehrzahl von thermischen Bimetallen umfasst.
2. Vorrichtung nach Anspruch 1, wobei die Vorrichtung (1) ein primäres thermisches Bimetall (12), das die Wechselwirkung zwischen einem Stopfen (7a, 7b) und der Einlassöffnung (5) bzw. der Auslassöffnung (6) beeinflusst, und ein sekundäres thermisches Bimetall (24) umfasst, das den Betrieb des primären thermischen Bimetalls (12) beeinflusst.
3. Vorrichtung nach Anspruch 2, wobei das primäre thermische Bimetall (12) ein herkömmliches thermisches Bimetall mit einer Aktivierungstemperatur von ungefähr 40°C ist.
4. Vorrichtung nach Anspruch 2 oder 3, wobei das sekundäre thermische Bimetall (24) ein thermisches bimetallisches Schnappelement mit einer höheren Schnapptemperatur von ungefähr 40°C und einer niedrigeren Schnapptemperatur von ungefähr 25°C umfasst.
5. Verwendung einer automatischen Reinigungsmittel-Abgabevorrichtung (1) für Waschmaschinen nach einem der Ansprüche 1 bis 4.

5

10

15

20

25

30

35

40

45

50

Revendications

1. Distributeur automatique portable de détergent pour lave-vaisselle (1) comprenant un corps (3) enfermant un détergent (2) ou additif de détergent, suffisant pour une pluralité de cycles de lavage, le corps ayant une ouverture d'entrée (5) pour permettre à la liqueur de lavage d'entrer en contact avec le déter-

55

gent et une ouverture de sortie (6) pour permettre à la liqueur de lavage chargée en détergent (2) de sortir du corps et des moyens pour fermer l'une ou les deux ouvertures au moment ou avant le début du cycle de rinçage du lave-vaisselle, et dans lequel les moyens de fermeture réagissent à un changement de température pendant le cycle de lavage du lave-vaisselle, et **caractérisé en ce que** les moyens de fermeture comprennent une pluralité de bimétaux thermiques.

2. Dispositif selon la revendication 1, dans lequel le dispositif (1) comprend un bimétal thermique principal (12) qui affecte l'interaction d'un bouchon (7a, 7b) avec l'ouverture d'entrée (5) /de sortie (6) et un bimétal thermique secondaire (24) qui affecte le fonctionnement du bimétal thermique principal (12).
3. Dispositif selon la revendication 2, dans lequel le bimétal thermique principal (12) est un bimétal thermique classique ayant une température d'activation d'environ 40°C.
4. Dispositif selon la revendication 2 ou 3, dans lequel le bimétal thermique secondaire (24) comprend un élément de transition bimétallique thermique ayant une température de transition supérieure d'environ 40°C et une température de transition inférieure d'environ 25°C.
5. Utilisation d'un distributeur automatique de détergent pour machine à laver (1) selon l'une quelconque des revendications 1 à 4.

Fig.1.

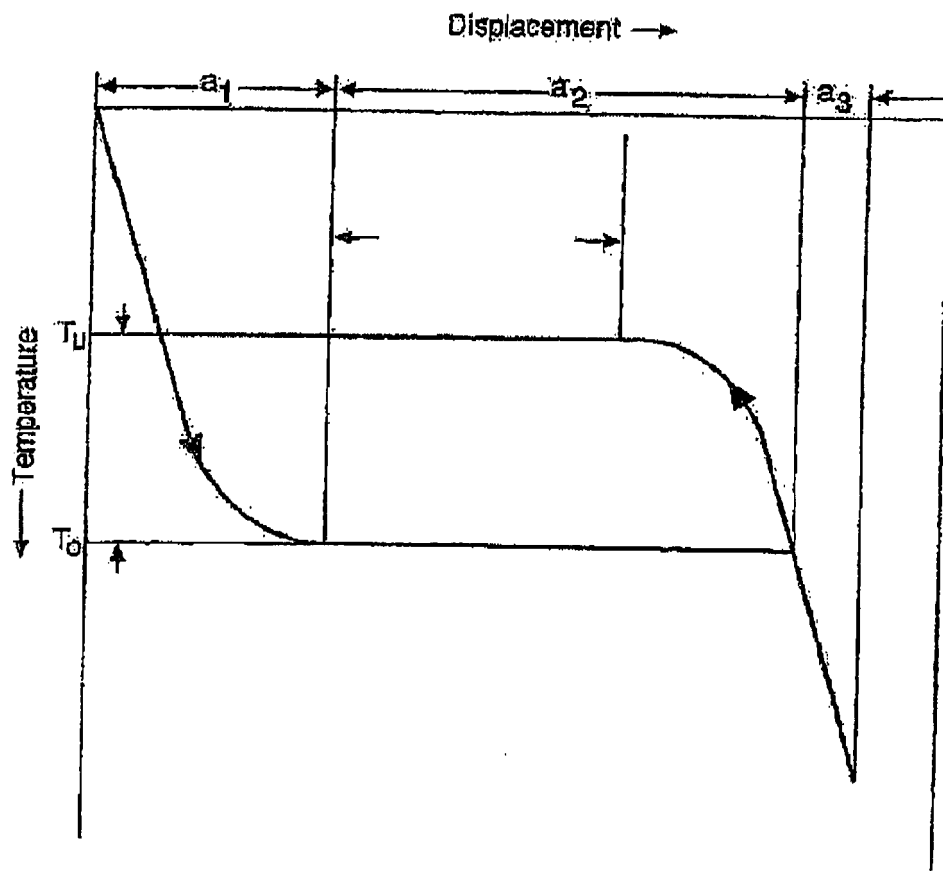

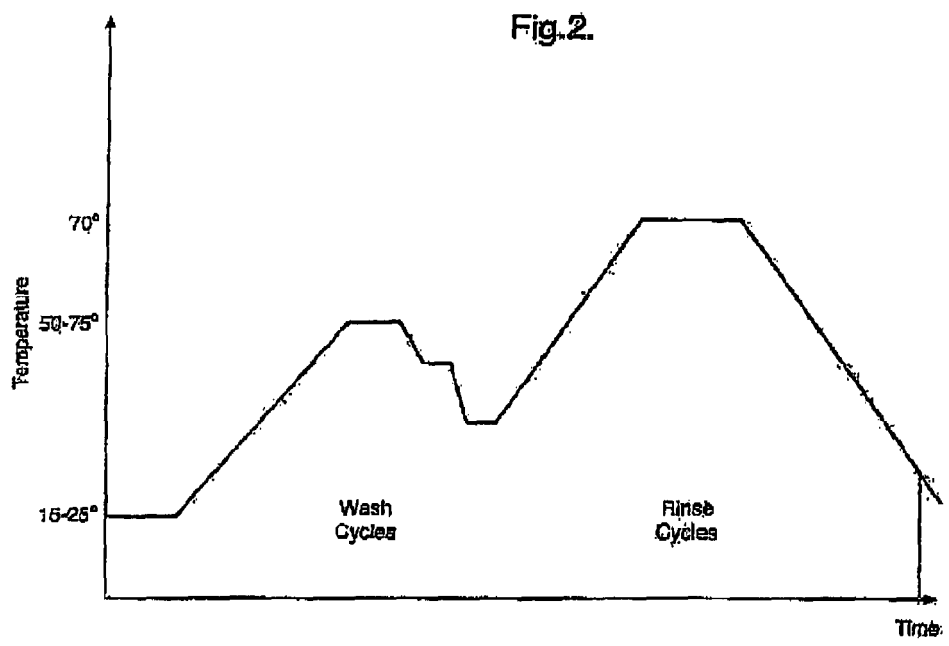

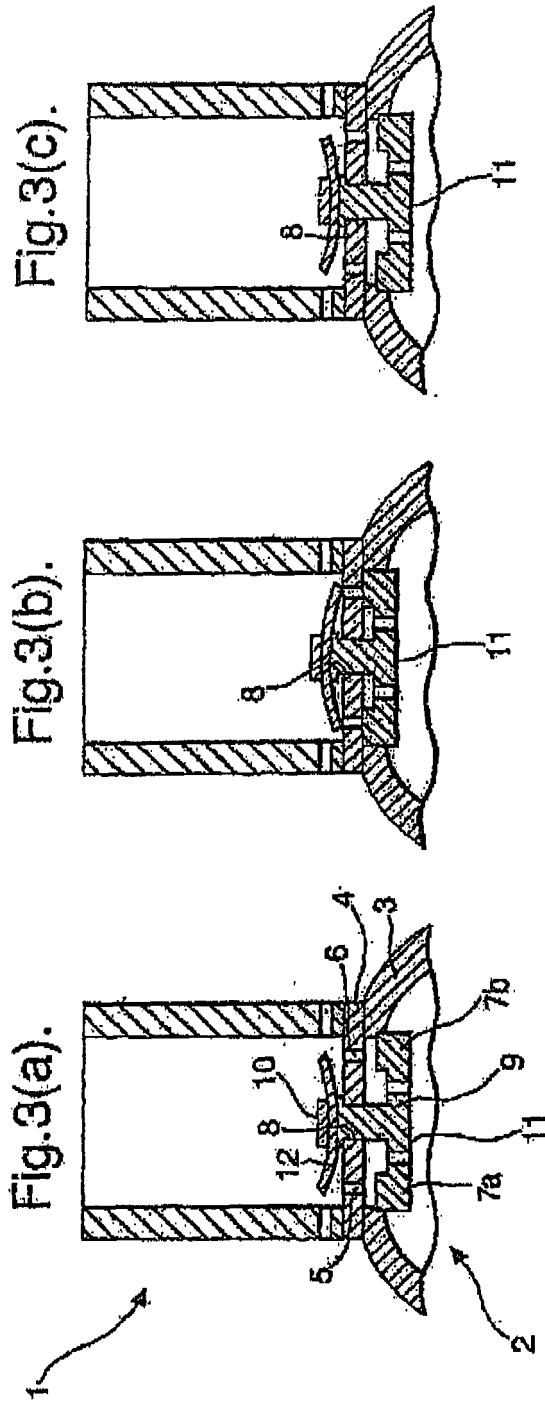

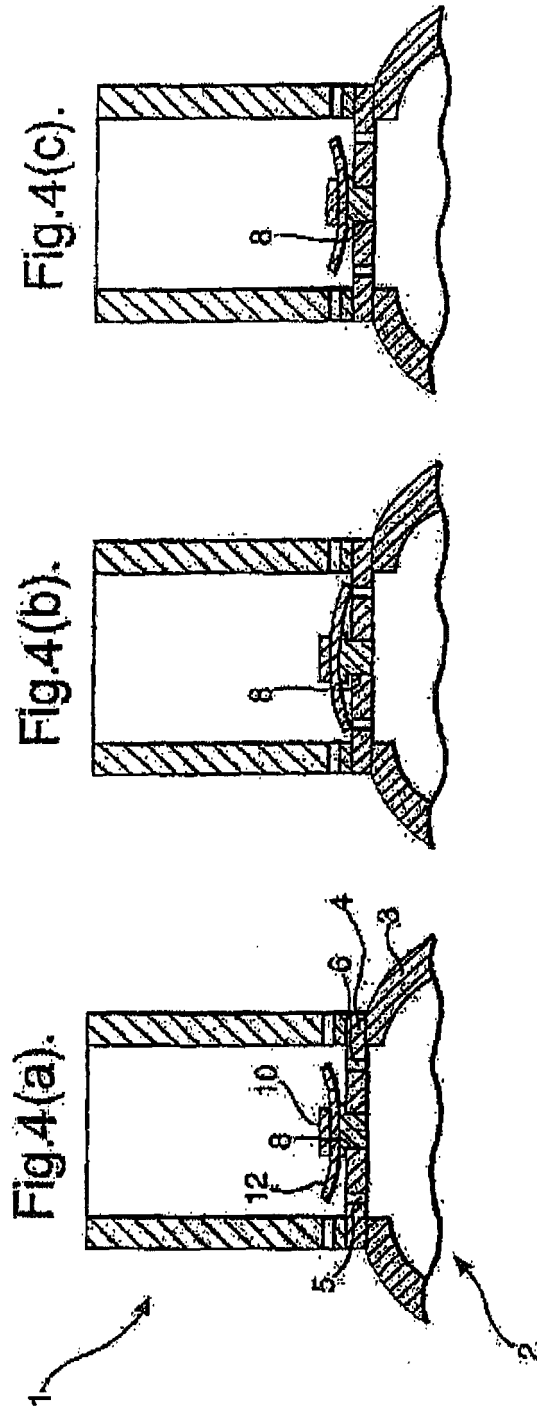

Fig.5.

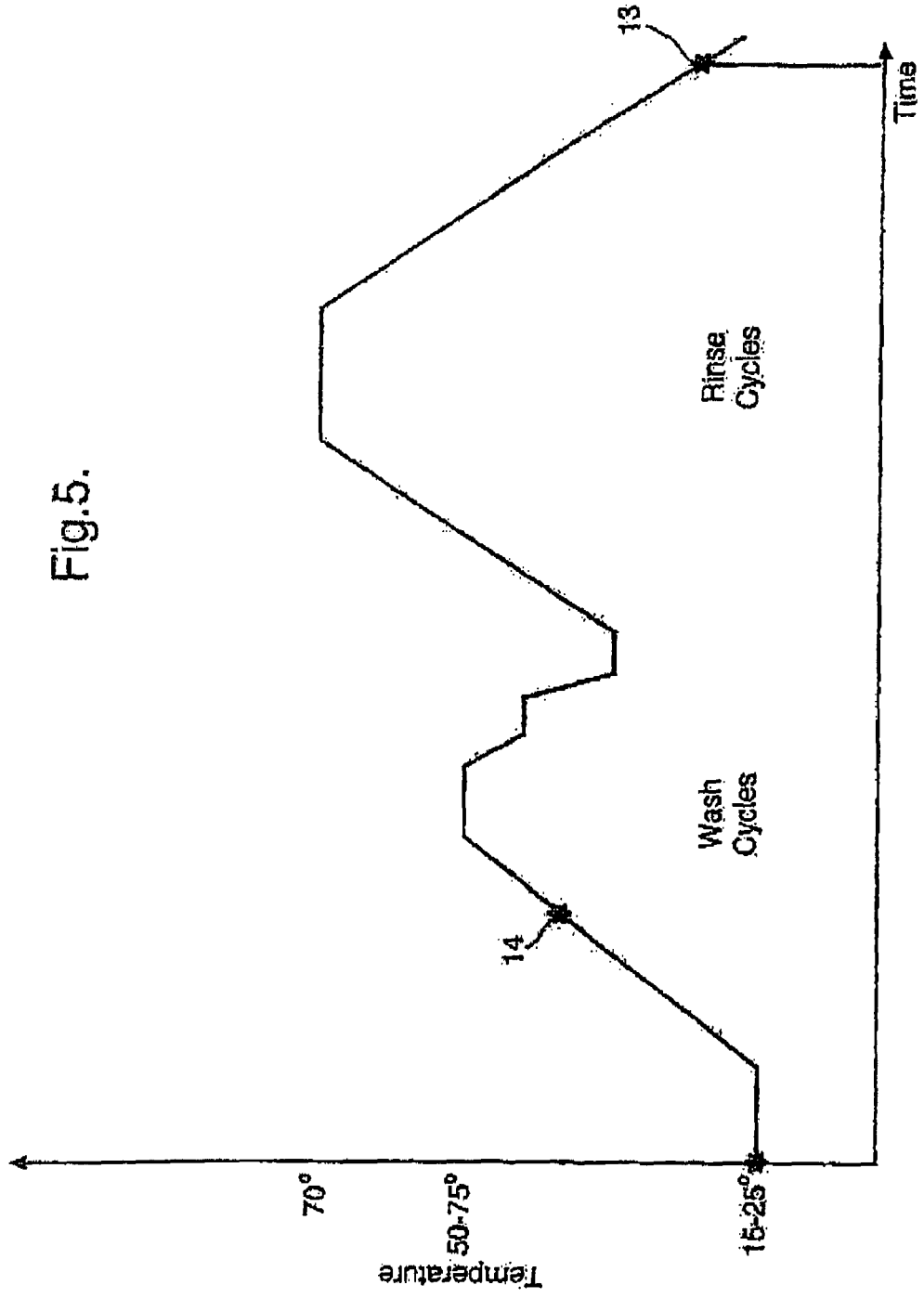

Fig. 6 (a).

Room Temperature

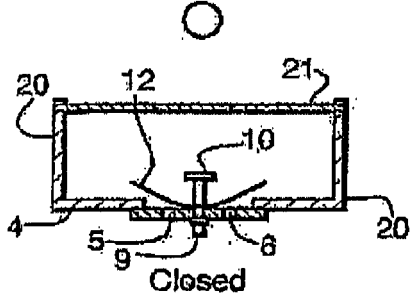

Fig. 6 (b).

30°C

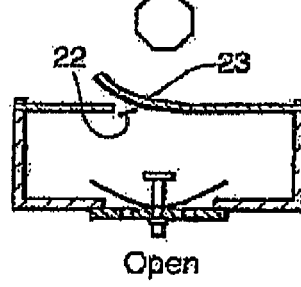

Fig. 6 (c).

40°C

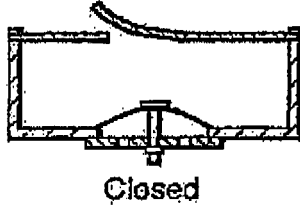

Fig. 6 (d).

>25°C
(Summer) Intermediate Cycle

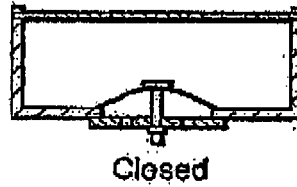

Fig. 6 (e).

<25°C
(Winter) Intermediate Cycle

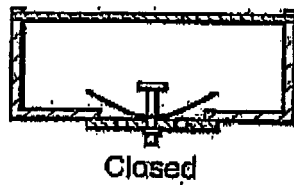

Fig. 7

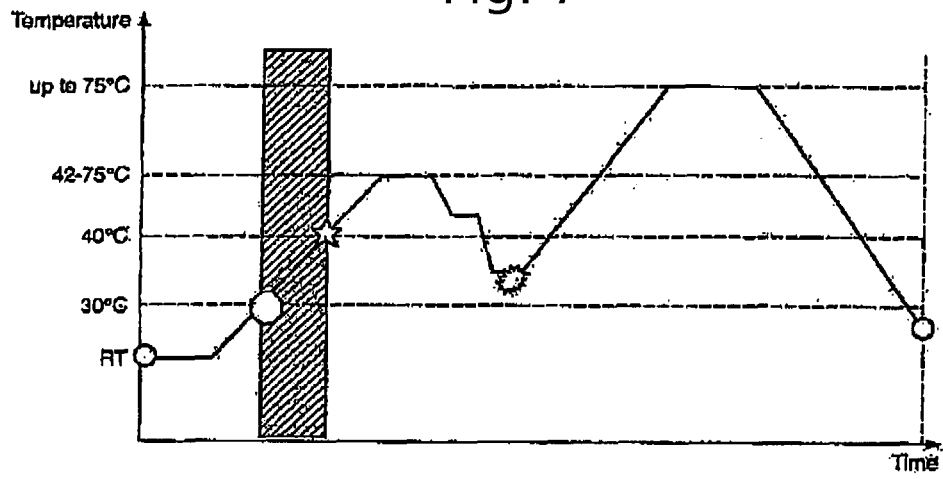

Fig. 8(a).

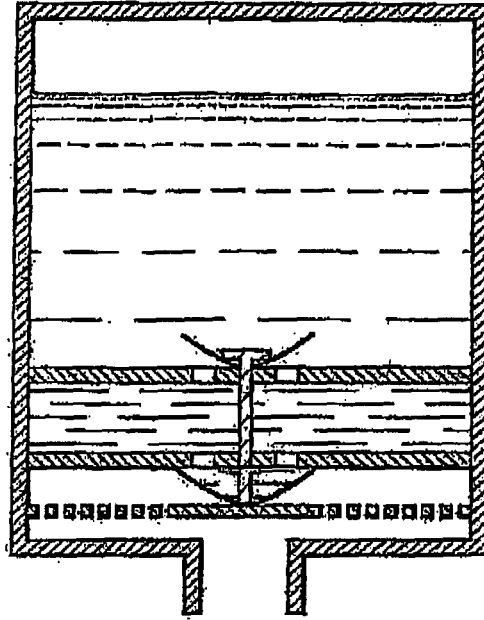
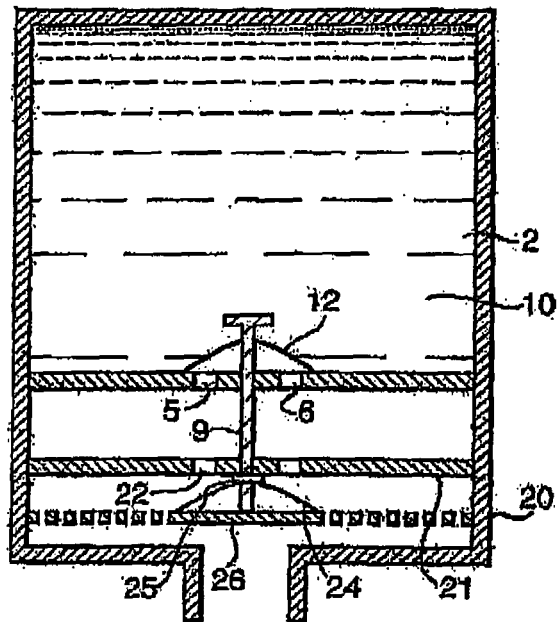

Fig. 8(b).



REFERENCES CITED IN THE DESCRIPTION

This list of references cited by the applicant is for the reader's convenience only. It does not form part of the European patent document. Even though great care has been taken in compiling the references, errors or omissions cannot be excluded and the EPO disclaims all liability in this regard.

Patent documents cited in the description

- WO 8806199 A [0005]
- DE 4344205 A1 [0006]
- WO 0107703 A [0007]
- US 21698022 B [0008]

Non-patent literature cited in the description

- *Feinwerktechnik, Microtechnik & Messtechnik*, 1995, vol. 103 [0022]