

June 17, 1941.

C. ERDMAN

2,245,968

PORTABLE GRINDING DEVICE

Filed Aug. 1, 1939

2 Sheets-Sheet 1

Fig. 3.

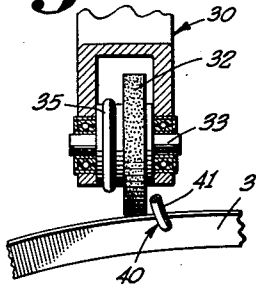

Fig. 1.

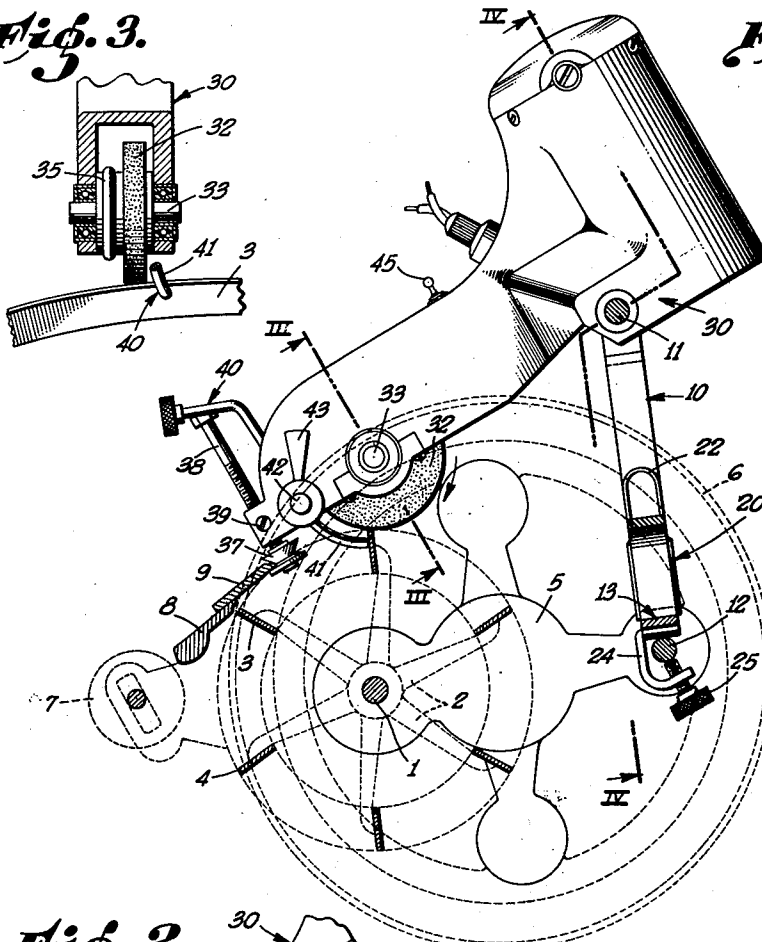
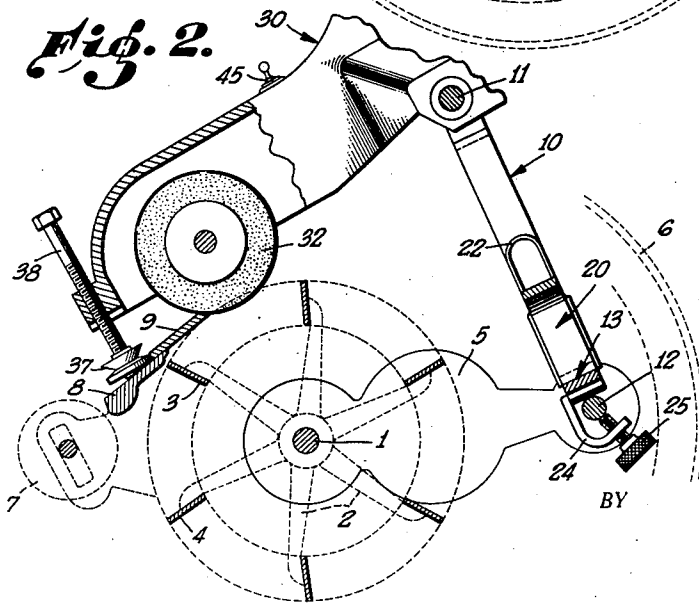

Fig. 2.



INVENTOR.
CALVIN ERDMAN

BY
C. J. Mitchell
ATTORNEY.

June 17, 1941.

C. ERDMAN

2,245,968

PORTABLE GRINDING DEVICE

Filed Aug. 1, 1939

2 Sheets-Sheet 2

Fig. 4.

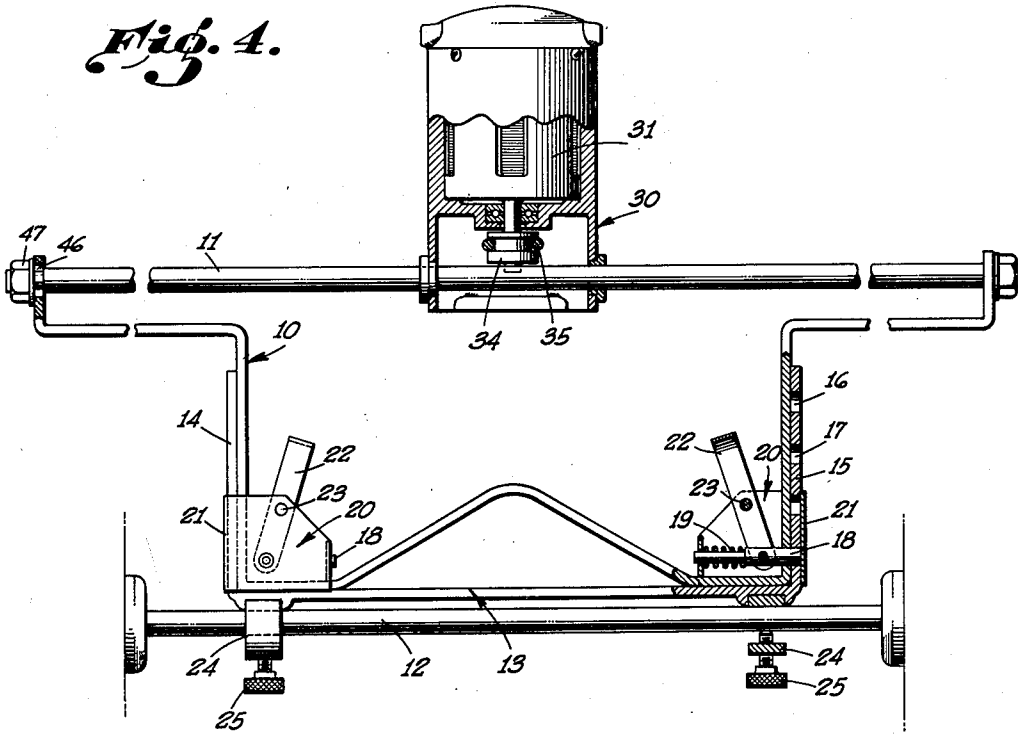

Fig. 5.

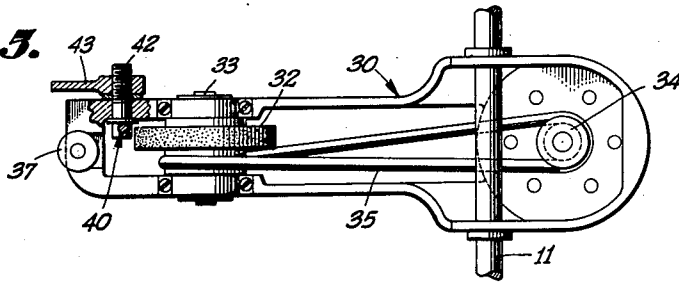

Fig. 6.

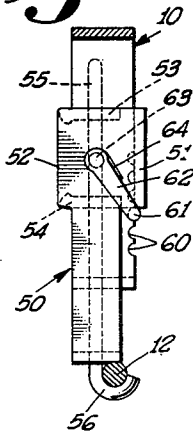
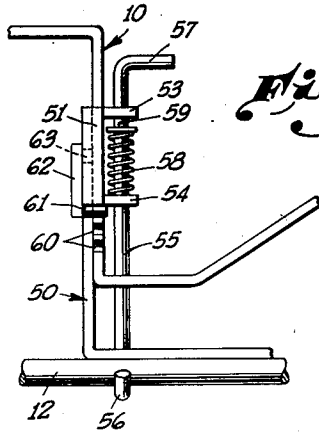

Fig. 7.



INVENTOR.
CALVIN ERDMAN

BY

C. J. Mikelly
ATTORNEY.

UNITED STATES PATENT OFFICE

2,245,968

PORTABLE GRINDING DEVICE

Calvin Erdman, Claremont, Calif.

Application August 1, 1939, Serial No. 287,709

2 Claims. (Cl. 51—249)

The present invention pertains to a portable grinding and sharpening device which is particularly adapted for use on lawnmowers although it may be used in sharpening various other tools and may be used as a portable grinder for numerous household and farm equipment. Generally stated, the invention pertains to a device whereby lawnmowers employing spiral blades may be sharpened without the necessity of dismantling the lawnmower.

The device of the present invention is light, portable and may be removably attached to a lawnmower so that the blades thereof can be sharpened readily and quickly without dismantling the lawnmower. Generally stated, the device includes a frame provided with a guide rod, the grinding unit being pivotally mounted upon such guide rod. The frame is removably attached to a lawnmower in such manner that the guide rod parallels the shaft upon which the blades are mounted. Means are provided on the device whereby the unit may be manually moved along the guide rod from one end to the other of the blade. Since the blades are arranged in spiral form around their rotational axis, stop means are provided on the device whereby these blades are made to present their edges to the grinding wheel carried by the unit as such unit is moved from one end to the other of the blade assembly.

An object of the present invention, therefore, is to disclose and provide a portable grinding and sharpening device which may be used in sharpening lawnmowers without taking the same apart.

A further object is to provide a portable grinding and sharpening unit which may be readily releasably attached to a lawnmower and used in sharpening the knives or cutting blades of the device.

A still further object is to provide a device which may be used in sharpening various household and farm equipment.

Other objects, advantages, characteristics, uses and adaptations of the device will become apparent to those skilled in the art from the description given hereinafter. In order to facilitate understanding, reference will be had to the appended drawings, in which:

Fig. 1 is a side view of the device, partly in section, and in operative position on a lawnmower.

Fig. 2 is an enlarged view of the grinding wheel end of the device in position for sharpening the cutter bar of a lawnmower.

Fig. 3 is a transverse section taken along the plane III—III of Fig. 1.

Fig. 4 is a view taken along the plane IV—IV of Fig. 1.

5 Fig. 5 is a view of the bottom of the grinding unit carriage.

Figs. 6 and 7 are side and front views respectively of a modified form of means for adjustably and releasably holding the device in position during sharpening of a lawnmower.

10 A lawnmower ordinarily includes a main shaft 1 carrying spiders 2 which support the knives 3, 4, etc., these knives being arranged around the shaft 1 in the form of spirals. The shaft 1 is driven by suitable gearing within a gear case 5 and the entire device is supported in rolling contact with the ground on the wheels 6. A roller, indicated at 7, also contacts with the ground.

20 In Fig. 1 the lawnmower is shown in an inverted position, resting against a wall or other support, since this is the position in which it may be most readily sharpened. In addition to the elements specifically referred to, a lawnmower also includes a back bar 8 carrying the cutter bar 9, the cutter bar 9 cooperating with the edges of the knives 3, 4, etc., in cutting the grass.

30 As shown in Figs. 1, 4 and 5, the device of this invention includes a frame 10 provided with a guide rod 11. Means are also provided for releasably connecting this frame 10 to some member paralleling the guide rod 11. On most lawnmowers a bar 12 connects the outer portions or gear cases 5, this bar 12 paralleling the driven mower shaft 1. The bar 12 is also shown in Fig. 4 and it will be seen that the frame 10 is releasably connectable to the bar 12 by means of an auxiliary U-shaped frame, generally indicated at 13, having the upstanding end portions 14 and 15, such upstanding portions being provided with perforations or apertures 16, 17, etc. The main frame 10 carries a reciprocable pin 18 which is yieldably urged outwardly by means of a spring 19, this pin and spring being retained within a housing 20 attached to the frame 10 and provided with a portion 21 enclosing the upstanding members 14 and 15 of the auxiliary frame 13. The pin 18 may be moved by means of a lever 22 pivoted as at 23 in the housing 20, a slot in the lower end of the lever 22 cooperating with a transverse pin extending from the locking pin 18. Manipulation of the levers 22 will withdraw the locking pins 18 from apertures in the ends of the auxiliary frame 13 and per-

mit such auxiliary frame to be moved downwardly from the position indicated in Fig. 4 and to be retained in some other position by engagement of the locking pins 18 with an upper aperture or port, thereby raising the guide rod 11 to some predetermined point above the bar 12.

The auxiliary frame 13 is attached to the rod 12 by means of the hook-like members 24 attached to the bottom of the auxiliary frame 13, these hook-like members 24 being provided with thumb screws 25, or other means, adapted to lock the auxiliary frame on the rod 12.

It is to be noted that the frame 10 is provided with a lower portion embraced by the auxiliary frame 13 and a wider upper portion, such wider upper portion carrying the guide rod 11. This permits the frame 10 to be attached to bars 12 on lawnmowers of different widths whereas the guide rod 11 is sufficiently long to extend over even the widest lawnmower.

Pivotaly mounted upon the guide rod 11 and slidable thereon is a grinding unit carriage generally indicated at 30 and extending transversely of the guide rod as shown in Fig. 5. One end of such carriage 30 may carry a motor 31 whereas the other end of the carriage may have a grinding wheel 32 suitably journaled thereon as upon the shaft 33 which preferably parallels the guide rod 11.

An operative connection exists between the motor and the grinding wheel 32 and as shown in Fig. 5, the motor shaft and pulley 34 may be connected to the shaft 33 of the grinding wheel by means of a belt 35. Preferably the motor 31 is mounted above and beyond the guide rod 11 when the entire device is in position on a lawnmower to sharpen the same, the center of gravity of the motor 31 now tending to counterbalance the other end of the grinding unit carriage 30. An adjustably positionable guiding wheel 37 is carried by the free end of the carriage 30. As shown in Fig. 1, the guiding wheel 37 may be provided with a groove adapted to receive the edge of the cutting bar 9. The guiding wheel 37 may be mounted for rotation on one end of a bolt 38, such bolt passing through a suitable internally threaded bore having its axis preferably at right angles to the axis of the guide rod 11. Means for holding the bolt in a predetermined position may be provided such as, for example, the set screw 39.

Means are also provided for guidingly directing the various blades 3, 4, etc., of the mower into engagement with the grinding wheel 32. As shown in the drawings, such means are indicated at 40 and comprise a member provided with a bent or arcuate lower portion 41 capable of being positioned adjacent the cutting surface of the grinding wheel 32 at various points. The member 40 may pass through a bore in the head of a bolt 42 rotatable in the side wall of the carriage 30 and capable of being locked in any desired position by means of a locking lever 43 threadably mounted on the bolt 42.

In operation the device is releasably attached to the bar 12 (or some other bar paralleling the mower shaft 1) while the lawnmower is in substantially inverted position. The guiding wheel 37 is caused to rest against the cutter bar 9 and the bolt 38 is manipulated until the surface of the grinding wheel 32 contacts with the cutting edge of one of the knives 3, 4, or the like, at a desired angle. The stop member 40 is then manipulated by means of the locking lever 43 until it rests against the mower blade and supports

the same in the desired position while the blade or knife is against the grinding wheel 32. Since the knife blades 3, 4 and the like are in the form of a spiral, the grinding unit carriage is moved to one end of the knife blades, the motor 31 started by actuating a switch such as the switch 45, and the entire grinding unit carriage is then moved along the guide rod 11 with the guiding wheel 37 in contact with the cutting bar 9, the mower blade or knife being thus sharpened from one end to the other. A similar sharpening operation is then carried out on the other mower blades in succession.

It will be noted that the edge of the blades, 3, 4, etc., may be hollow ground and the sharpness of the resulting edge may be varied by changing the position of the stop member 40 and the elevation of the guiding wheel 37.

If it is then desired to sharpen the cutter bar 9, the grinding unit carriage 30 is slightly lifted and moved so as to place the guiding wheel 37 against the back of the cutter bar 9, the elevating means 38 being manipulated so as to bring the grinding wheel 32 into contact with the edge of the cutting bar 9. The carriage 30 will have to be maintained in this position by hand, the wheel 37 being pressed against the back of the cutting bar 9 manually in order to prevent the grinding wheel 32 from cutting into the cutter bar 9 with unnecessary force. The stop member 40 may be adjusted so as to help support the carriage on the edge of the cutting bar 9, as shown in Fig. 2, and also prevent the spiral blades from accidentally contacting the grinding wheel.

Since the frames of many mowers are slightly warped, it may be desirable to adjustably position one end of guide bar 11 in frame 10 as by providing a slot 46 in the end of the frame, the nut 47 being tightened after a necessary adjustment is made.

It will be obvious to those skilled in the art that the U-shaped portion of the frame 10 may be so constructed as to permit the housing of the motor 31 to be swung beneath the bar 11, thereby exposing the bottom of the carriage 30 and rendering the grinding wheel 32 accessible from the top. In this position the entire unit may be used for grinding and sharpening various small utensils such as knives, scissors, and the like.

In Figs. 6 and 7 a modified form of means for releasably attaching the main frame 10 to a bar such as the bar 12, is shown. In this modified form the auxiliary frame 50 is provided with a flange 51 adapted to encircle one edge of the frame 10 and with another flange 52 having bent portions 53 and 54 encircling the other edge of the frame. These bent portions 53 and 54 are perforated or bored so as to slidably receive a bar 55 provided with a hook 56 at its lower end and an arm 57 at its upper end. A spring 58 yieldably urges the bar 55 upwardly by pressure against a pin 59 passing through such bar. The auxiliary frame 50 is thus releasably attachable to the bar 12. In order to adjustably position the auxiliary frame 50 with respect to the main frame 10, one edge of the main frame 10 may be provided with serrations or depressions 60 adapted to receive a key 61 carried by a lever arm 62 pivoted as at 63, a spring 64 tending to move the lever 62 and its key 61 into one of the selected depressions or serrations 60. Such key may be manually released when desired.

Although a specific form of device has been described in detail, it will be understood that

numerous changes and modifications can be made from this exemplary form, and all adaptations or modifications or uses of the invention described and embodied in the claims are deemed to be a part of this invention.

I claim:

1. A portable grinding and sharpening device adapted for use on lawnmowers, which comprises: a frame including a relatively narrow lower portion and a wide upper portion provided with a guide rod; spring actuated, manually releasable means for removably connecting said frame to a member paralleling said guide rod; a grinding unit carriage extending transversely of said guide rod and pivoted thereon, said carriage being manually slidable on said guide rod and including a grinding wheel journaled near one end of said carriage, a bent stop member adjacent said grinding wheel, means for adjustably varying the position of the end of said stop member with respect to said grinding wheel in three planes; a guiding wheel rotatably mounted on an adjustable support carried by said carriage adjacent said grinding wheel, and a motor carried by the other end of said carriage and tending to counterbalance said grinding wheel when the device is in position on a lawnmower, whereby

the grinding wheel may gravitationally rest upon a knife of a mower during grinding.

2. A portable grinding and sharpening device adapted for use on lawnmowers, which comprises: a frame including a relatively narrow lower portion and a wide upper portion provided with a guide rod; manually releasable means for removably connecting said frame to a member paralleling said guide rod; a grinding unit carriage extending transversely of said guide rod and pivoted thereon, said carriage being manually slidable on said guide rod and including a grinding wheel journaled near one end of said carriage, a bent stop member adjacent said grinding wheel, means for adjustably varying the position of the end of said stop member with respect to said grinding wheel in three planes; a guiding wheel rotatably mounted on an adjustable support carried by said carriage adjacent said grinding wheel and a motor carried by the other end of said carriage and tending to counterbalance said grinding wheel when the device is in position on a lawnmower, whereby the grinding wheel may gravitationally rest upon a knife of a mower during grinding.

CALVIN ERDMAN.