

J. S. TEMPLETON.

Improvement in Looms.

No. 128,675.

Patented July 2, 1872.

FIG. 1.

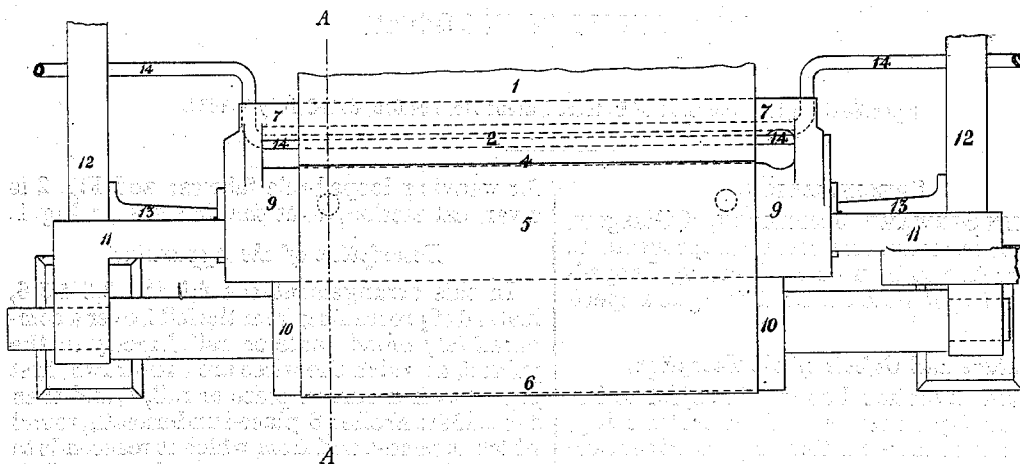
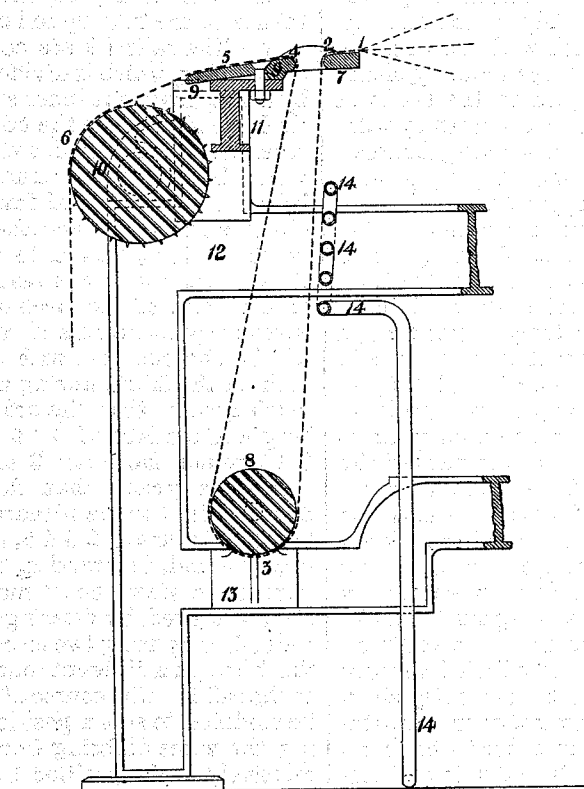

FIG. 2.



Witnesses
 Edmund Hunt
 Wallace Fairweather

SCALE 1/2 IN = 1 FOOT.

J. S. Templeton

UNITED STATES PATENT OFFICE.

JOHN S. TEMPLETON, OF GLASGOW, SCOTLAND.

IMPROVEMENT IN LOOMS.

Specification forming part of Letters Patent No. 128,675, dated July 2, 1872.

SPECIFICATION.

I, JOHN STEWART TEMPLETON, of Glasgow, Scotland, have invented certain Improvements in Apparatus to be used in Weaving Looped-Pile Fabrics, of which the following is a specification:

Nature and Objects of the Invention.

My said invention has for its object to improve looped-pile fabrics; and consists in using, as hereinafter more particularly described, apparatus or means whereby a more perfect and permanent form is given to the pile-loops than is done by the apparatus commonly employed in weaving such fabrics. My invention is applicable, in connection with well-known appliances, for producing the looped pile by means of transverse wires inserted in the sheds as the weaving proceeds, and subsequently withdrawn from the fabric, as in weaving Brussels carpets, for example. In applying my present improvements, I employ apparatus constructed and arranged in a novel manner, as hereinafter described, so as to enable a considerably larger number of the wires to be used than has been usual heretofore; and, further, to enable each wire to remain a comparatively longer time in the fabric, so that the form it tends to give to the loops becomes more set or fixed than in fabrics woven in the ordinary looms. This result is obtained by changing the ordinary direct line of travel of the newly-woven part of the fabric between the fell and the taking-up roller and deflecting that line of travel, so that while the relative positions of the fell and the taking-up roller remain the same, there is a much longer length of newly-woven fabric between them in which the wires can be advantageously left for a longer time than in looms of the ordinary construction. The object is effected without altering, or, at any rate, inconveniently altering, the distance that each wire, when it is withdrawn, has to be carried in order to be introduced into a fresh shed. In order to still further improve the pile-loops, and to render them more permanent in form, I in some cases apply heat to the fabric while the wires are in it, and so arrange my heating apparatus that the heat is applied so as not to produce inconvenience.

Description of the Accompanying Drawing.

Figure 1 is a plan of the front part of a loom

for weaving looped-pile fabrics; and Fig. 2 is a vertical section, as at the line A A in Fig. 1.

Description of the Apparatus.

In this arrangement the fabric 1 2 3 4 5 6, instead of proceeding from the fell 1 over a comparatively broad plate or rail directly to the point 5, at which the wires are withdrawn, first passes over a narrow plate or rail, 7, and then descends to a roller, 8, placed underneath, round which it passes and from which it reascends to a second comparatively-narrow plate or rail, 9, over which it continues its course to the point 5 for withdrawing the wires, passing on thence to the take-up roller 10 in the ordinary way. The rails 7 9 are conveniently made in one casting, which is divided into the two parts by a slot, down one inner side of which the fabric descends and up the other sides of which it ascends. If preferred, two rails may, as is obvious, be employed. The rail-casting 7 9 is bolted to a horizontal frame-bar, 11, fixed to the side frames 12, and the roller 8 is held by brackets 13, also fixed to the side frames 12. This arrangement requires no interference with or alteration of the mechanism by which the wires are withdrawn and reintroduced; but it will be obvious that with it each wire will remain in the fabric during a period which is as much greater than the ordinary period as the length of the fabric 1 2 3 4 5, as taken from the fell 1 round the roller 8 to the withdrawing-point 5, is greater than the distance directly from the fell 1 to the withdrawing-point 5. The length of course 1 2 3 4 5, shown in the drawing, is found, in practice, to be ample for the purpose in view; but it may obviously be varied, if desired, by altering the position of the roller 8, or by using two or more rollers to guide the fabric in a different course before it returns to the rail 9. The course of the fabric may also be modified to suit a position, 5, for withdrawing the wires differing from the ordinary one relatively to the position 1 for introducing the wires.

When heat is applied to the fabric it is necessary to take care that it be so applied as not to inconveniently heat the surface of the fabric or the inserted wires, and to insure this I apply it to the fabric as it is descending with the wires in it from the inner rail 7 to the roller 8, and I use for the purpose a simple steam-pipe,

14, which is bent so as to run horizontally from side to side any convenient number of times, and I place the heating apparatus where its heat will not be inconvenient in proximity with the back or inner side of the descending fabric.

I am aware that previous attempts have been made to apply heat to a looped-pile fabric while the wires are held in it by means of a steam-box placed in the position occupied by the rail-casting 7 9, but the plan was found not to be successful on account of the difficulty and serious inconvenience caused by the heated state of the wires and by the upward radiation of the heat in that situation.

With the arrangement of the fabric and heating appliance, as herein described and delineated, the difficulty that has hitherto been experienced is obviated, and no inconvenience is caused, as the fabric takes a long time in traveling from the position where the heat is ap-

plied before reaching the rail 9, so that by the time it does so the fabric and wires are well cooled.

Claims.

1. The combination of the rails 7 and 9 with the roller 8, substantially as described, whereby a looped-pile fabric passes through a deflected course between the fell and take-up roller or between the points where the wires are introduced and the point where they are withdrawn, as set forth.

2. In combination with the rails 7 and 9 and the roller 8, the heating-pipes 14, substantially as and for the purpose set forth.

J. S. TEMPLETON.

Witnesses:

EDMUND HUNT,
WALLACE FAIRWEATHER.