

E. THOMSON.
LIGHTNING ARRESTER.

No. 493,314.

Patented Mar. 14, 1893.

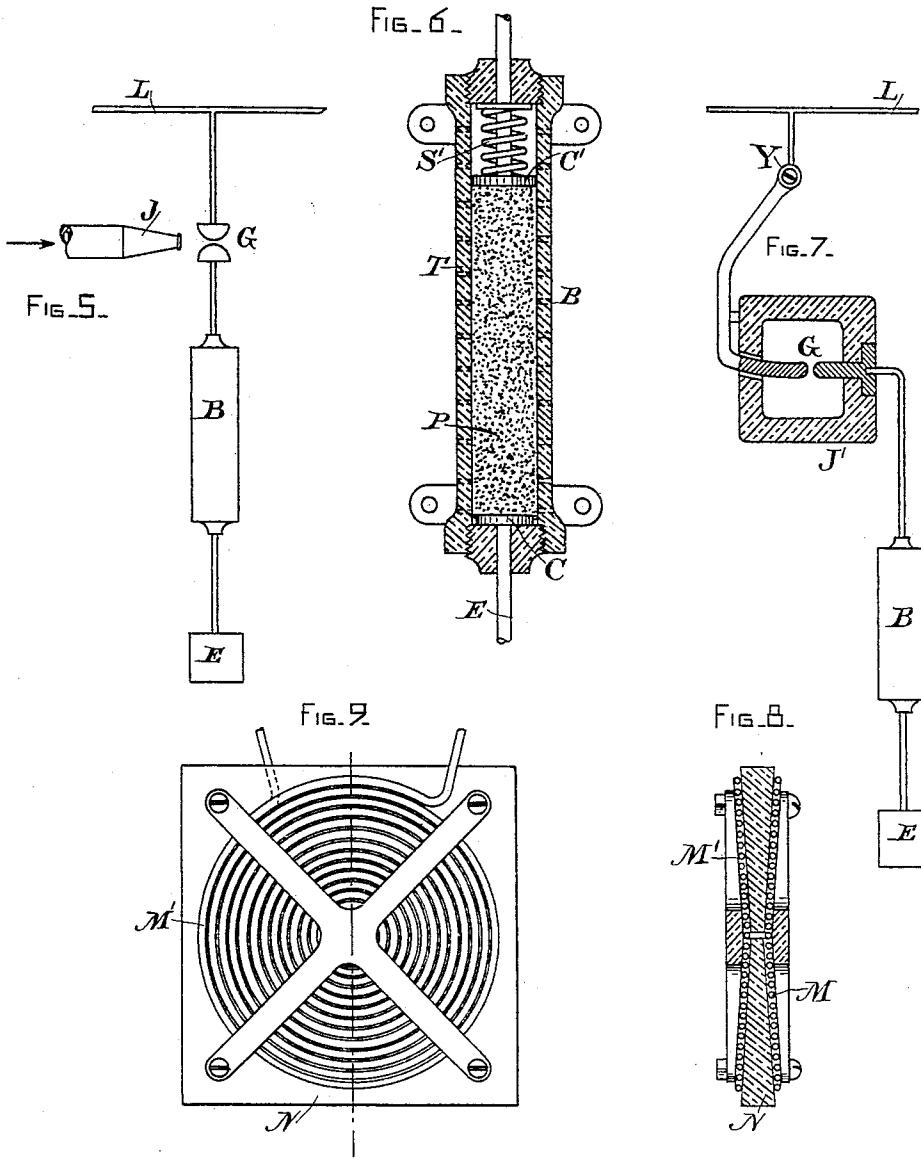

WITNESSES.
Alec F. McDonald.
A. D. Case

INVENTOR.
Elisha Thomson
By Bentley & Bloodgett
Attys.

E. THOMSON.
LIGHTNING ARRESTER.

No. 493,314.

Patented Mar. 14, 1893.

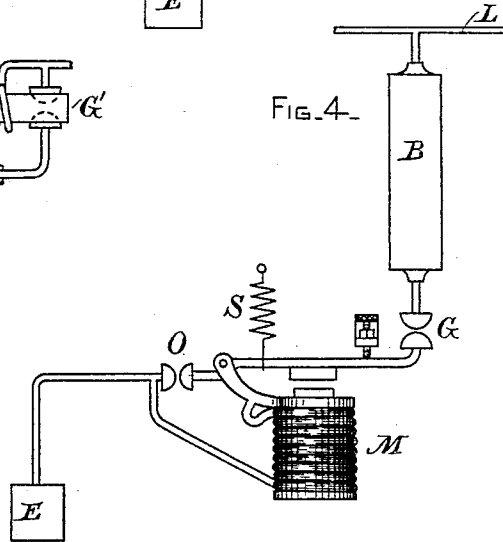
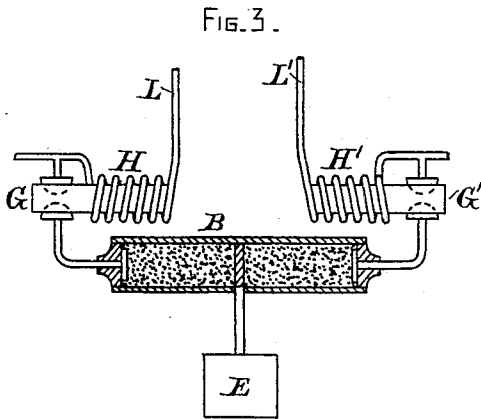
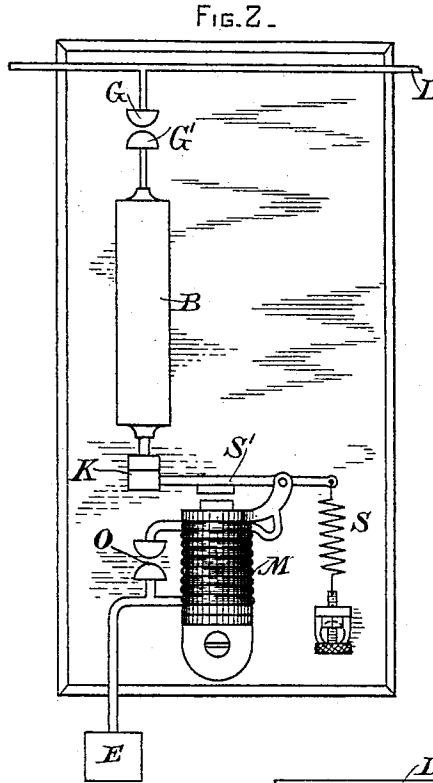
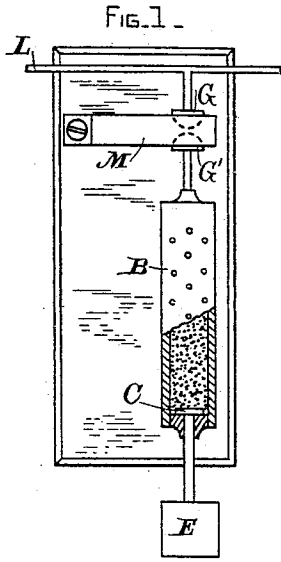

WITNESSES.

Alec F. Macdonald.
A. D. Druce

INVENTOR.
E. Thomson
By B. B. B. B. B. B. B. B. B.
Attys.

UNITED STATES PATENT OFFICE.

ELIHU THOMSON, OF SWAMPSCOTT, MASSACHUSETTS, ASSIGNOR TO THE
GENERAL ELECTRIC COMPANY, OF NEW YORK.

LIGHTNING-ARRESTER.

SPECIFICATION forming part of Letters Patent No. 493,314, dated March 14, 1893.

Application filed October 28, 1892. Serial No. 450,224. (No model.)

To all whom it may concern:

Be it known that I, ELIHU THOMSON, a citizen of the United States, residing at Swampscott, county of Essex, and State of Massachusetts, have invented a certain new and useful Improvement in Lightning-Arresters, of which the following is a specification.

The aim of the present invention is to avoid the continuance of arcs on an electric circuit, and consequent injury to the discharge terminals across which the arc exists, together with other known evils.

The invention will be found particularly useful on power circuits of such voltage and character that an arc when once established is followed by a rush of current of such volume that the ordinary arc rupturing devices with difficulty disrupt it.

It consists principally in supplementing or assisting this disruptive action by employing means for limiting or checking the flow of after current to an amount less than would otherwise be the case so that the arc rupturing devices may quickly and certainly extinguish the arc.

In a lightning arrester there is combined with the discharge plates and arc rupturing devices commonly employed a resistance in the ground connection, which resistance is as non-conductive in character as possible, and limits the line current tending to follow a discharge to ground to such an amount as will permit the arc to be readily extinguished when once established over the spark gap or gaps of the arrester.

On railway or similar power circuits it has been found by experience that a short circuit at the arrester plates, even though powerful means for blowing out the arc are provided, is often attended by destructive effects at the plates, and is furthermore almost invariably attended by opening of the circuit breakers of the circuit from the dynamos, indicating that the current obtained from the constant potential or over-compounded machines commonly present in the power station is of such enormous amount that the ordinary means for rupturing the arc are often insufficient for that purpose. To cut down this volume of current as already indicated, I insert in the ground branch a resistance of such character as to

give the least possible opposition to lightning discharges, while at the same time offering such resistance to the continued passage of the line current that the arc may be broken.

In the accompanying drawings, Figures 1, 2, 3, 4, 5, 6 and 7 show the invention applied to various forms of lightning arresters of constructions generally similar to those now well known in the art; and Figs. 8 and 9 illustrate a modified form of resistance which may be used.

In Fig. 1, L represents a line circuit which is connected to ground at E. The ordinary arrester plates separated by a spark gap are shown at G, G', and an arc rupturing magnet is provided at M. One of the plates G is connected to line, and the other G' to earth through a resistance B of a definite, determinate amount sufficient to give the desired effect, and which for illustration on a five hundred volt circuit will be, say, from five to ten ohms. This resistance will be as free from self-induction as possible. I prefer for this purpose a wooden box or earthenware tube filled with carbon sand and provided with end plates C in contact with the sand, the length and section of the conducting path being adjusted to give the required resistance. Fine perforations may be provided in the box for letting out any gases which may form from time to time without letting the particles of sand escape.

In Fig. 2 a generally similar arrangement is shown, but with a modified form of lightning arrester. A spark gap is provided between the plates G, G' and the arc rupturing device is supplied by the contacts at K which are separated by an electro-magnet M when current passes to earth, the magnet M being in the earth branch, and shunted by a small spark gap at O which the discharge takes first so as to prevent injury of the magnet. A spring S holds the armature S' in such position as to close the contacts until the discharge takes place. By using the limiting resistance B the arc may be broken at K by a movement of the contacts through a considerably shorter space than would otherwise answer, and danger is also to a large extent avoided of melting the contacts K so as to stick and to refuse to open at all.

In Fig. 3 the arc rupturing devices are shown as two magnets, one in each of the line circuit wires L, L' which are coiled respectively around the magnets at H, H'. One of the plates of each arrester is connected to the resistance B which is grounded at E so that a resistance of the required amount will be included in the path from either of the arrester plates. A single tube filled with carbon sand is shown provided with a central connection to earth.

Fig. 4 shows the spark gap at G between the resistance B and earth, and an electro magnet M, acting as already described in connection with Fig. 2, may be inserted to widen the spark gap to any desired extent to extinguish the arc between the plates.

Figs. 5 and 7 show an arrangement similar to Fig. 1, except that in the former an air jet J is used to disrupt the arc, and in the latter the discharge terminals are inclosed in a box J' such that the heat of the arc itself by expanding the air in the box blows apart the terminals, one of which is pivoted at Y as shown.

In Fig. 6 a mode of constructing the resistance is shown having as before a surrounding tube T of non-conducting material, such as indurated fiber or earthenware, having at one end a terminal plate C in contact with the carbon sand P, and at its other end a top plate C' pressed down against the carbon by a spring S' so as to make good contact therewith.

While I have described carbon sand as the most suitable resistant material, other materials like metallic oxides in fine grains may be used to provide a resistance having the necessary non-inductive character, and which can be adjusted to offer the desired amount of resistance without being too unwieldy or bulky.

In Figs. 8 and 9 another form of resistance is shown which may be used though not so easily constructed as that already described. Here a resistance wire is coiled into two flat spirals M², M' on the two sides of a sheet or plate N of glass or porcelain, the spirals being wound reversely and connected at their centers so as to give as high an insulation between the terminals as possible while maintaining a demagnetizing effect upon each other, so that self-induction is nearly if not entirely abolished. The length and section of the wires should be so proportioned to the normal voltage of the line as to give such a de-

gree of resistance as will limit the current to an amount such that the ordinary arc rupturing apparatus can be relied upon to act with certainty and promptness.

What I claim as new, and desire to secure by Letters Patent, is—

1. The combination of circuit terminals at which an arc is liable to form with an arc rupturing device for extinguishing an arc thereat, and a resistance or current reducing means to limit the current flowing across said terminals incidental to arcing thereat.

2. The combination of lightning arrester discharge terminals arranged to form a spark gap or gaps, with an arc rupturing device for extinguishing an arc thereat, and means for limiting or reducing the current tending to follow the passage of the discharge to earth.

3. The combination with a lightning arrester having a spark gap and arc rupturing devices, of a resistance non-inductive in character limiting or reducing the current passing from line to ground incident to arcing at the spark gap.

4. The combination with a lightning arrester having a spark gap or gaps with a resistance of non-inductive character, and a circuit leading to ground comprising the spark gap and resistance in series such that the after-flow of line current must pass through said resistance in going to earth, as set forth.

5. The combination with a lightning arrester having a spark gap or gaps and arc rupturing devices, of a resistance in the ground connection, consisting of carbon sand or like granular resistant material arranged to give the desired limiting effect upon the current flowing from line to ground upon arcing at the spark gap, as described.

6. The combination with a lightning arrester having a spark gap or gaps and arc rupturing devices, of a resistance consisting of a confined mass of carbon sand permanently in circuit in the ground connection and arranged to offer a definite, determinate resistance to the flow of current from line to ground, as described.

In testimony whereof I have hereto set my hand this 25th day of October, 1892.

ELIHU THOMSON.

Witnesses:

JOHN W. GIBBONEY,
BENJAMIN B. HULL.