

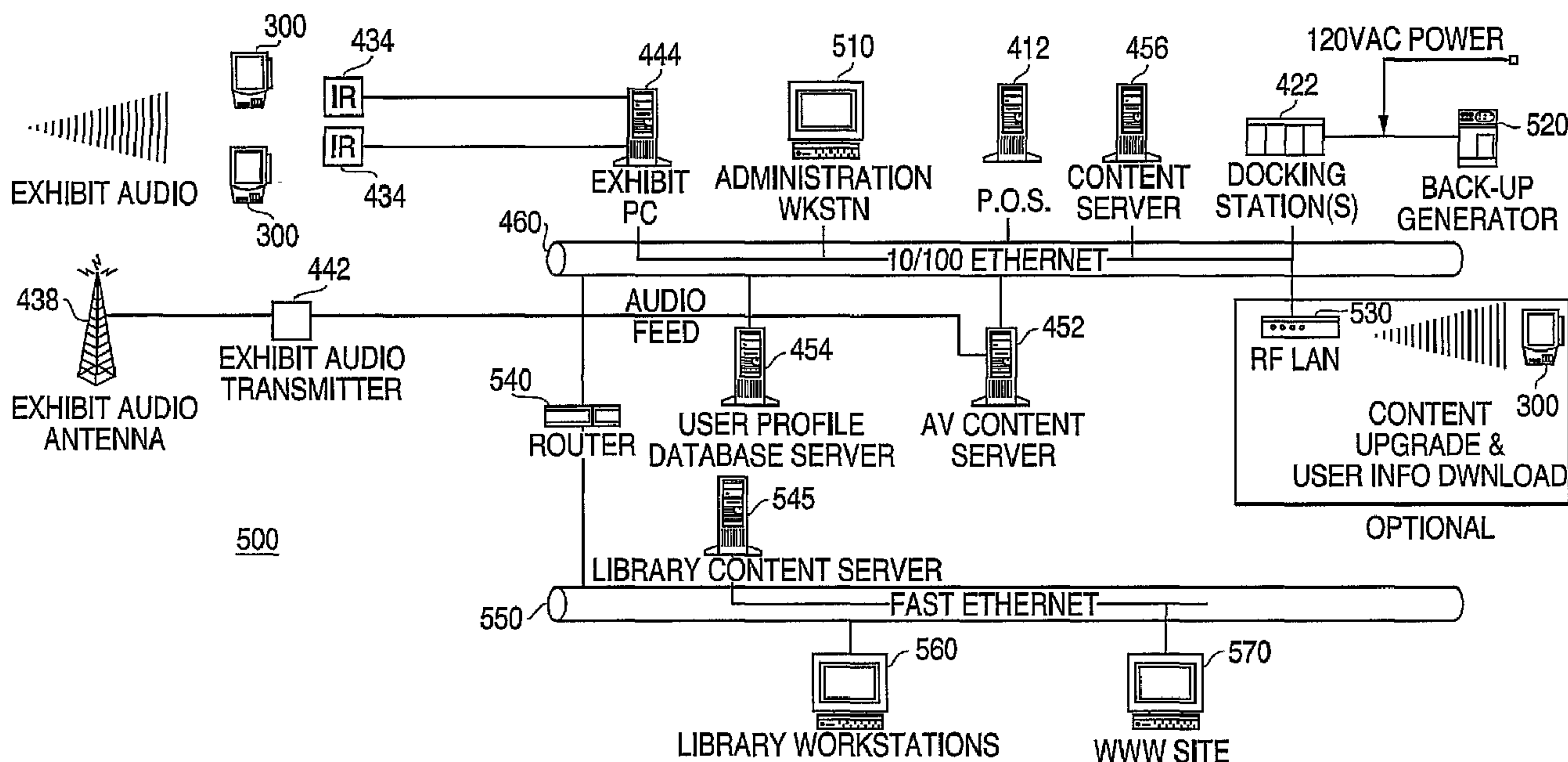

(86) Date de dépôt PCT/PCT Filing Date: 2001/06/15  
 (87) Date publication PCT/PCT Publication Date: 2001/12/27  
 (45) Date de délivrance/Issue Date: 2008/12/30  
 (85) Entrée phase nationale/National Entry: 2002/12/13  
 (86) N° demande PCT/PCT Application No.: US 2001/019084  
 (87) N° publication PCT/PCT Publication No.: 2001/098913  
 (30) Priorité/Priority: 2000/06/16 (US09/594,697)

(51) Cl.Int./Int.Cl. *G06Q 50/00* (2006.01)  
 (72) Inventeur/Inventor:  
 FITZSIMMONS, ROBERT LEE JR., US  
 (73) Propriétaire/Owner:  
 VULCAN NORTHWEST, INC., US  
 (74) Agent: BORDEN LADNER GERVAIS LLP

(54) Titre : APPAREIL D'AFFICHAGE PERMETTANT DE COMPLETER L'EXPERIENCE D'UN VISITEUR  
 (54) Title: DISPLAY FACILITY SUPPLEMENTING EXPERIENCE OF A VISITOR



(57) **Abrégé/Abstract:**

Audio, video, text and image presentation systems (300) allow visitors to display facilities and other public spaces to proactively select detailed information about the various items located within such facilities and spaces. Exemplary, embodiments can be used in a museum exhibition to convey detailed information relating to museum artifacts. Alternatively, embodiments can be used in a convention center or retail environment to deliver information relating to products or services. Advantageously, information content delivered to the user includes high-quality audio, video and static images and, through a combination of selection functionality and bookmarking functionality, exemplary systems provide a link between the public space elements (e.g., artifacts, products, services, etc.) and additional, still more detailed information delivered off-line via another medium such as the World Wide Web (WWW) (570) or a fixed workstation (560) environment within the public space. Consequently, a visitor can self-guide and self-tailor his or her exploration of a display facility or other public space; and/or extend his or her experience beyond the physical boundaries of the display facility or other public space.

(12) INTERNATIONAL APPLICATION PUBLISHED UNDER THE PATENT COOPERATION TREATY (PCT)

CORRECTED VERSION

(19) World Intellectual Property Organization  
International Bureau(43) International Publication Date  
27 December 2001 (27.12.2001)

PCT

(10) International Publication Number  
WO 01/098913 A1

- (51) International Patent Classification<sup>7</sup>: G06F 15/00, 17/60, 17/30
- (21) International Application Number: PCT/US01/19084
- (22) International Filing Date: 15 June 2001 (15.06.2001)
- (25) Filing Language: English
- (26) Publication Language: English
- (30) Priority Data:  
09/594,697 16 June 2000 (16.06.2000) US
- (71) Applicant: VULCAN NORTHWEST, INC. [US/US];  
505 Union Station, Suite 900, 505 Fifth Avenue South,  
Seattle, WA 98104 (US).
- (72) Inventor: FITZSIMMONS, Robert, Lee, Jr.; 5030  
Beach Drive, S.W., Seattle, WA 98136 (US).
- (74) Agents: WRENN, Michael, A. et al.; Cooley Godward,  
LLP, Attn: Patent Group, One Freedom Square, 11951  
Freedom Drive, Reston, VA 20191-5601 (US).
- (81) Designated States (*national*): AE, AG, AL, AM, AT, AU,  
AZ, BA, BB, BG, BR, BY, BZ, CA, CH, CN, CO, CR, CU,  
CZ, DE, DK, DM, DZ, EE, ES, FI, GB, GD, GE, GH, GM,  
HR, HU, ID, IL, IN, IS, JP, KE, KG, KP, KR, KZ, LC, LK,  
LR, LS, LT, LU, LV, MA, MD, MG, MK, MN, MW, MX,  
MZ, NO, NZ, PL, PT, RO, RU, SD, SE, SG, SI, SK, SL,  
TJ, TM, TR, TT, TZ, UA, UG, UZ, VN, YU, ZA, ZW.
- (84) Designated States (*regional*): ARIPO patent (GH, GM,  
KE, LS, MW, MZ, SD, SL, SZ, TZ, UG, ZW), Eurasian  
patent (AM, AZ, BY, KG, KZ, MD, RU, TJ, TM), European  
patent (AT, BE, CH, CY, DE, DK, ES, FI, FR, GB, GR, IE,  
IT, LU, MC, NL, PT, SE, TR), OAPI patent (BF, BJ, CF,  
CG, CI, CM, GA, GN, GW, ML, MR, NE, SN, TD, TG).
- Published:  
— with international search report

[Continued on next page]

(54) Title: DISPLAY FACILITY SUPPLEMENTING EXPERIENCE OF A VISITOR

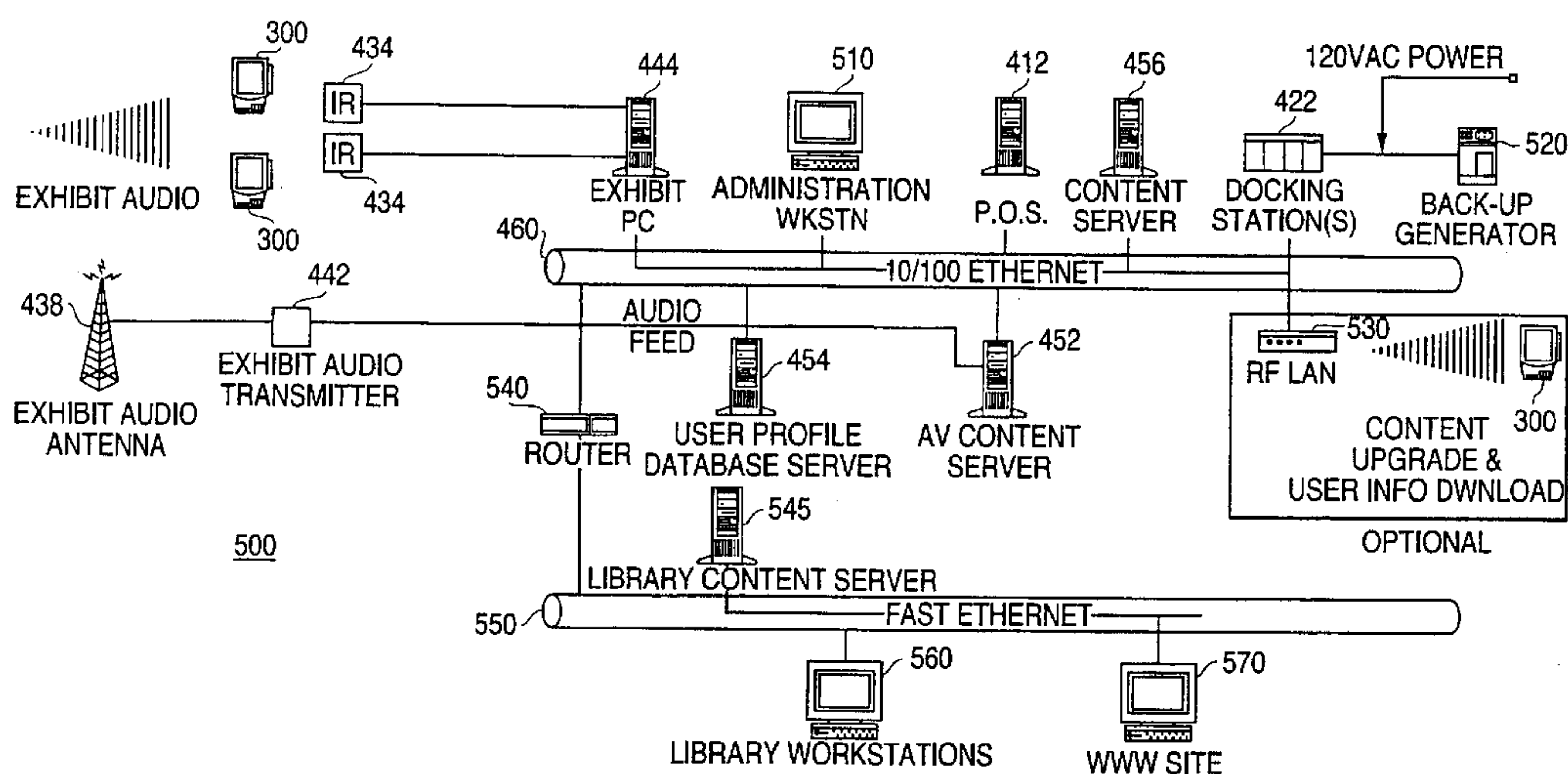

(57) Abstract: Audio, video, text and image presentation systems (300) allow visitors to display facilities and other public spaces to proactively select detailed information about the various items located within such facilities and spaces. Exemplary embodiments can be used in a museum exhibition to convey detailed information relating to museum artifacts. Alternatively, embodiments can be used in a convention center or retail environment to deliver information relating to products or services. Advantageously, information content delivered to the user includes high-quality audio, video and static images and, through a combination of selection functionality and bookmarking functionality, exemplary systems provide a link between the public space elements (e.g., artifacts, products, services, etc.) and additional, still more detailed information delivered off-line via another medium such as the World Wide Web (WWW) (570) or a fixed workstation (560) environment within the public space. Consequently, a visitor can self-guide and self-tailor his or her exploration of a display facility or other public space; and/or extend his or her experience beyond the physical boundaries of the display facility or other public space.

WO 01/098913 A1

**WO 01/098913 A1**



**(48) Date of publication of this corrected version:**

4 July 2002

*For two-letter codes and other abbreviations, refer to the "Guidance Notes on Codes and Abbreviations" appearing at the beginning of each regular issue of the PCT Gazette.*

**(15) Information about Correction:**

see PCT Gazette No. 27/2002 of 4 July 2002, Section II

**DISPLAY FACILITY SUPPLEMENTING EXPERIENCE OF A VISITOR****BACKGROUND****5 Field of the Invention**

The present invention relates to display facilities and other public spaces and, more particularly, to techniques for enhancing a visitor's experience within such a facility or space, and extending a visitor's experience beyond the physical constraints of such a facility or space.

10

**Discussion of the Related Art**

Traditionally, display facilities and other public spaces (e.g., museums, convention centers, retail stores, etc.) are constructed such that patrons passively view static objects and/or live or prerecorded presentations available in the facility or space (e.g., paintings and other artifacts, consumer electronics and other merchandise, live skits or audio / video and computer-generated demonstrations, etc.). More recently, however, display facilities and other public spaces have been equipped with technology intended to enrich the visitor experience and to provide more user control over the experience. For example, some museums now provide visitors with portable devices that enable those visitors to listen to accompanying audio when viewing artifacts. Additionally, some display facilities equip exhibits (e.g., with push-buttons) so that visitors are able to select among a number of available audio or video presentations. However, known techniques still provide for relatively little visitor control, and do not provide opportunity to extend the visitor experience beyond the physical boundaries of the public spaces themselves. Consequently, there is a need for improved methods and apparatus for enriching the experience of a visitor to a display facility or other public space.

25

30

**SUMMARY OF THE INVENTION**

In an attempt to address these shortcomings of the known visitor experience, the present invention provides audio, video, text and image presentation systems that allow visitors to display facilities and other public spaces to proactively select detailed

information about the various items located within such facilities and spaces. For example, exemplary embodiments can be used in a museum exhibition to convey detailed information relating to museum artifacts. Alternatively, embodiments can be used in a convention center or retail environment to deliver information relating to products or services. According to one embodiment, information content delivered to the user includes high-quality audio, video and static images. Also, through a combination of selection functionality and bookmarking functionality, exemplary systems provide a link between the public space elements (e.g., the artifacts, products, services, etc.) and additional, still more detailed information delivered off-line via another medium such as the World Wide Web (WWW) or a fixed workstation environment proximate the public space. Consequently, the invention enables a visitor to self-guide and self-tailor his or her exploration of the display facility or other public space, and further enables the visitor to extend his or her experience beyond the physical boundaries of the display facility or other public space.

An exemplary method of supplementing the experience of a visitor to a public space having a plurality of artifacts includes the steps of: associating a unique identifier with each of the plurality of artifacts; recording, as the visitor traverses the public space, identifiers associated with artifacts the visitor indicates as being of interest to the visitor; and providing the visitor, after the visitor has completed traversing the public space, additional information relating to the artifacts associated with the recorded identifiers. The step of recording can, for example, include the step of providing the visitor a portable selection device, the portable selection device enabling the visitor to select and store identifiers associated with artifacts of interest. In exemplary embodiments, the recorded identifiers are downloaded from the portable device to a user profile database when the visitor has completed traversing the public space.

Advantageously, the step of providing the visitor additional information can include the step of making the recorded identifiers available via a WWW site tailored to further research relating to the artifacts associated with the recorded identifiers. Alternatively, the step of providing the visitor additional information can include the step of making the recorded identifiers available via a workstation in the public space, the workstation being tailored to identify public space content and/or provide further

content relating to the artifacts associated with the recorded identifiers. Moreover, the step of providing the visitor additional information can include the step of making the recorded identifiers available to a public space point-of-sale server, the point-of-sale server being tailored to personalize the visitor's subsequent visits to the public space based on the recorded identifiers and/or to keep the visitor apprised of events relating to the artifacts associated with the recorded identifiers. Advantageously, the public space can, according to exemplary embodiments, be any type of public space, including a museum, a convention center, a retail store, a sporting arena, an open-air exhibit, etc.

These and other features and advantages of the invention are described hereinafter with reference to a number of exemplary embodiments depicted in the accompanying drawings. Those of skill in the art will appreciate that the exemplary embodiments are provided by way of illustration only, and that numerous equivalent embodiments are also contemplated herein.

## **BRIEF DESCRIPTION OF THE DRAWINGS**

Figure 1 depicts a portable user selection device according to an exemplary embodiment of the invention.

Figures 2A and 2B depict a portable content and control device according to an exemplary embodiment of the invention.

Figure 3 is a block diagram of an exemplary portable display interface device, including an exemplary user selection device and an exemplary content and control device of the invention.

Figure 4 is a block diagram of an exemplary display facility according to the invention.

Figure 5 is a block diagram of an exemplary network configuration within a display facility according to the invention.

Figures 6A and 6B depict exemplary screen displays on a portable user selection device according to the invention.

Figure 7 is a flow chart depicting steps in an exemplary method of capturing and utilizing visitor activity within a display facility or other public space in order to enhance

the visitor's experience while in the display facility or other public space and/or to extend the visitor's experience beyond the display facility or other public space.

### DETAILED DESCRIPTION

5 In one possible implementation of the invention, each visitor to a display facility or other public space is provided a portable interface device that enables the user to select and listen to information related to artifacts displayed within the facility (hereinafter, the term facility is used generically to represent any known type of display facility or public space, including museums, convention exhibits, retail displays, sporting arenas, open-air  
10 exhibits, etc.; additionally, the term artifact is used generically to refer to any suitable display item, including static objects, video and computer displays, merchandise, etc.). Advantageously, the portable interface device serves as a facility-savvy companion and private tour guide to the facility visitor, providing the visitor an aesthetically pleasing, robust, and full-featured multimedia experience (effectively providing depth for the  
15 facility's breadth). Moreover, by recording visitor selections made within the facility, the portable interface device permits the visitor experience to be extended beyond the physical boundaries of the facility.

According to an exemplary embodiment, the portable interface device includes a content and control unit tethered, via a multi-wire cable, to a separate user selection  
20 device. Generally speaking, the content and control unit houses processing power and data content for the portable interface device, while the user selection device provides a user-friendly and interactive link between the portable interface device and the facility visitor.

Figure 1 depicts an exemplary user selection device 100 according to one  
25 embodiment of the invention. As shown, the selection device 100 includes an outer casing 110, a bookmark key 115, a liquid crystal display (LCD) screen 120, and an indicator light 125. Additionally, the selection device 100 includes a Clear key 130, a Select key 135, a Help key 140, a Volume Control rocker switch 145, a Display Brightness Control rocker switch 150, a keypad including twelve numeric keys 155  
30 arranged as on an ordinary telephone, a Review key 160, a Play / Pause key 165, a Forward key 170, a Stop key 175, and a connection port 180 (to accommodate the above

noted tether to the content and control device). The exemplary user selection device 100 is a handheld device and, as is described in more detail hereinafter with respect to Figures 3 and 4, enables a visitor to access content corresponding to artifacts displayed within a suitably constructed facility.

5           Figures 2A and 2B depict, respectively, front and rear perspective views of an exemplary content and control unit 200 according to one embodiment of the invention. As shown, the content and control unit 200 includes a main outer casing 210, an audio output port 220, an audio input port 225, a retaining arm 230, a cradle 240, a harness bracket 250, and a connection port 260 (to accommodate the multi-wire tether from the  
10 connection port 180 of the user selection device 100). The exemplary content and control unit 200 is worn on the visitor's person (e.g., via a shoulder strap or harness attached to the bracket 250), and the cradle 240 and the retaining arm 230 together provide a place for storing the user selection device 100 when not in use. As is described in more detail below with respect to Figures 3 and 4, the content and control device 200  
15 controls operation of the user selection device 100 and provides selected content to the visitor (e.g., via a user headset plugged into the audio output port 220).

Figure 3 depicts components for one embodiment of an exemplary portable interface device 300 that includes the exemplary user selection device 100 of Figure 1 and the exemplary content and control device 200 of Figure 2. It will be appreciated that  
20 the component configuration of Figure 3, as well as the physical configurations of Figures 1 and 2 are exemplary in nature. In practice, the user selection device 100 and the content and control device 200 can take on any suitable physical shape, and the exemplary components shown in Figure 3 can be distributed between the devices 100, 200 in any suitable manner (e.g., the components of the separate devices 100, 200 can be  
25 combined into a single device if desired).

As shown, the exemplary content and control device 200 includes a main processor 305, a dynamic random access memory (DRAM) 310, a flash memory 315, a display buffer 320, a display driver 325, and a battery 330. Additionally, the exemplary content and control device 200 includes a network interface port 332, a communications  
30 buffer 334, an Integrated Drive Electronics (IDE) hard disk 336, a Personal Computer Memory Card International Association (PCMCIA) controller 338, a PCMCIA card 340,

an analog front end (AFE) controller 342, an audio decoder 344, a digital to analog converter 346, a radio frequency (RF) audio receiver 348, an analog audio mixer 350, and an analog stereo amplifier 352. As shown, the exemplary user selection device 100 includes a microprocessor 360, a touch screen 364, the LCD screen 120, the indicator  
5 light 125 (alternately referred to as a glowing orb), and an infrared (IR) receiver 370.

In operation, the main processor 305 (e.g., the well known Toshiba<sup>TM</sup> 129 MHz TX3922) provides information and menu options to the display facility visitor via the LCD 120, and receives input (e.g., menu selections, requests for help, control commands, etc.) from the visitor via the touch screen 364 (which can be integral with the LCD  
10 screen, and which communicates with the main processor 305 through the AFE 342) and/or via the various selection device input keys 115, 130, 135, 140, 155, 160, 165, 170, 175 (shown in Figure 1, but not shown in Figure 3). Additionally, the main processor 305 provides feedback to the user via the indicator light 125, and receives information from the display facility via the IR receiver 370 (as is described in greater detail below  
15 with respect to Figure 4). Within the user selection device 100, the microprocessor 360 (e.g., the well known Dallas DS87C550<sup>TM</sup> processor) provides an interface between the main processor 305 and various selection device components as shown.

In addition to providing the above described functionality, the main processor 305 records user input (e.g., key presses) on the IDE hard disk 336, and retrieves user selected  
20 content (e.g., compressed audio files) from the IDE hard disk 336 as the user traverses the display facility. Moreover, when the portable interface device 300 is not in use, the main processor 305 communicates with an external display facility server via the interface port 332 (e.g., an Ethernet 10b/T port located in the base of the content and control device 200) or via the PCMCIA controller 338 (e.g., where the PCMCIA card  
25 340 is configured for wireless communication via an RF local area network, or LAN). Communications with the external server enable the main processor 305 to upload current content and/or application software and to download recorded visitor input. All of the above described functionality of the main processor 305 is made more clear hereinafter by way of the description of Figure 4. In exemplary embodiments, the main  
30 processor 305 runs the well known Windows CE Version 2.x<sup>TM</sup> operating system, and application specific functionality is provided via software written in the well known

Visual C++<sup>TM</sup> language.

As is also shown in Figure 3, the stereo amplifier 352 receives analog input from the analog mixer 350, and provides amplified audio output to the user (e.g., via a stereo headset plugged into the analog output 220, under control of the user via the Volume Control rocker switch 145). Advantageously, the mixer 350 can receive input from four different audio sources as appropriate. Specifically, the mixer 350 can receive: operating system sounds from the main processor 305 (via the AFE 342); audio content retrieved from the IDE hard disk 336 by the main processor 305 (and decompressed either by the main processor 305 itself, or by a separate audio decoder 344, depending upon design considerations); RF audio picked up by the RF receiver 348 from an external RF source (e.g., a display facility transmitter); and/or external audio received via the audio input port 225. Again, these aspects of the content and control device 200 are made more clear immediately hereinafter by way of the description of Figure 4.

Fig. 4 depicts an exemplary display facility 400 in which the exemplary interface device 300 of Figure 3 can be used. As shown, the exemplary facility 400 includes an entry 405, a reception area 410, a device docking area 420, first and second galleries 430, 431, first and second auxiliary equipment centers 440, 441, and a main equipment center 450. The reception area 410 includes a point-of-sale (POS) server 412, and the device docking area 420 includes a number of device docking stations 422.

Additionally, the first gallery 430 includes a number of exhibit areas 432, a corresponding number of IR transmitters 434, a plurality of proximity loop transmitters 436, and a plurality of RF antennae 438. The first auxiliary equipment center 440 includes an RF audio transmitter 442 and an exhibit server 444. Although the second gallery 431 and the second auxiliary equipment center 441 are shown empty in Figure 4, it will be understood that they include components analogous to those found in the first gallery 430 and the first auxiliary center 440, respectively.

The main equipment center 450 includes an audio/video (AV) server 452, a user profile database server 454, and a content server 456. Each of the servers 412, 444, 452, 454, 456, as well as each of the docking stations 422, is connected to a common communications network 460 (e.g., an Ethernet 10b/T network). Additionally, the AV server 452 is coupled to the RF audio transmitter 442, and the RF transmitter 442 is in

turn coupled to each of the RF antennae 438. Finally, the exhibit server 444 is coupled to each of the IR transmitters 434.

Upon entering the facility 400, a visitor is directed to the reception area where, according to embodiments of the invention, he or she can obtain a ticket to view the artifacts displayed within the facility. The POS server (which can utilize any of several well known POS systems) provides a ticket having a unique identifier (e.g., a unique barcode number). In addition to the ticket, the visitor receives a portable interface device 300 such as that described above with respect to Figures 1-3. As the portable interface device 300 is given, or checked out, to the user, the unique ticket number is uploaded to the portable interface device 300 and stored on the internal hard disk 336 within the content and control device 200. For example, the user selection device 100 can include a bar code scanner (not shown in Figures 1 and 3) which can be swiped across the ticket to automatically read the unique barcode imprinted thereon.

Upon receiving the portable interface device 300, the visitor is free to traverse the visitor-accessible portions of the facility (e.g., the galleries 430, 431). In the exemplary facility 400 of Figure 4, it is presumed that artifacts are grouped within exhibits 432, and that exhibits 432 are in turn grouped within galleries 430, 431. Note, however, that these groupings are arbitrary and, in practice, the facility artifacts can be partitioned in any suitable manner.

In the embodiment of Figure 4, proximity detectors 436 (e.g., RF loop transmitters embedded within the facility floor as is well known in the art) are used to inform the portable interface device 300, via the internal RF receiver 348, that the visitor has entered a specific gallery 430, 431, or has approached a specific exhibit 432. Thus, the portable interface device 300 can, for example, provide the visitor with context sensitive menu selections, help functions, etc. Additionally, the proximity detection can be used to tune the internal RF receiver 348 to appropriate RF channels being broadcast over the RF antennae 438 (the antennae 438 being driven by the RF transmitter 442, which is in turn driven by the AV server 452).

As an alternative, or supplement, to the proximity loop transmitters 436 positioned at the exhibits 432, the IR transmitters 434 can provide gallery and exhibit identification to the portable interface device 300 via the IR receiver 370 internal to the

user selection device 100. According to exemplary embodiments, each IR transmitter 434 continually transmits a gallery/exhibit identification code (e.g., xx/yy, where xx represents the particular gallery, and yy represents the particular exhibit), and the visitor is instructed to aim the user selection device 100 at an easily recognizable symbol  
5 positioned near the IR transmitter 434 while simultaneously depressing the Select key 135. Depressing the Select key 135 momentarily activates the internal IR receiver 370 so that the gallery and exhibit identification can be detected (otherwise, the IR receiver 370 is powered down to conserve the life of the battery 330, which in the embodiment of Figure 3 powers the components in both the content and control device 200 and the  
10 selection device 100). Alternatively, the IR receiver 370 can sample for exhibit IR, not only when the user presses the select key, but also at fixed intervals. By doing so, the portable interface device 300 can update the user location if necessary (e.g., in the event the user forgets to press the select key when approaching a new exhibit).

Once the visitor has approached an exhibit, the portable interface device 300  
15 provides the user an opportunity to select additional information about the artifacts in the exhibit. For example, each artifact can be labeled with a unique identifier (e.g., a two or three-digit number), and the visitor can enter the identifier via the numeric keys 155 of the selection device 100. Alternatively, or additionally, the identifiers for the artifacts in the exhibit can be presented to the visitor via the LCD screen 120, and the visitor can  
20 select a particular artifact via the integral touch screen 364. Once an artifact identifier has been entered by the visitor, corresponding content is retrieved from the internal hard disk 336 and made available to the visitor (e.g., a compressed MP3 audio file including a narrative and/or music is retrieved and played for the visitor via stereo headphones as described above with respect to Figure 3, and/or text and images are displayed to the user  
25 via the LCD display 120). Ensuring that artifact identifiers are not repeated in adjacent exhibits assists the portable interface device in determining the user location (e.g., when the user enters a numeric entry that is not valid at the most recently selected exhibit, the device can remind the user to make sure he or she has selected the present exhibit).

Once the visitor has completed his or her tour of the facility 400, the visitor  
30 returns, or checks in, the portable interface device 300 (e.g., in the same reception area 410 where the device was originally checked out), and the portable interface device 300

is docked in one of the stations 422 for battery recharging and data / content transfer. Recall, for example, that visitor keystrokes are stored on the internal hard disk 336 as the visitor traverses the facility and selects artifacts of interest. Thus, in the embodiment of Figure 4, the stored keystrokes (and the unique ticket ID associated with the visitor

5 entering the keystrokes) are downloaded from the docked portable interface device 300 to the user profile database server 454 (where they are thereafter made available to various applications, as described in detail below). Additionally, the content server 456 can, when necessary, upload new content and programming code to the docked portable interface device. According to exemplary embodiments, the various servers 412, 444,

10 452, 454, 456 are implemented as personal computers running the well known Windows 2000<sup>TM</sup> operating system (with application specific functionality being provided by software written in the also well known Visual C++<sup>TM</sup> programming language).

Figure 5 depicts the system communications aspects of the exemplary facility 400 of Figure 4 in greater detail. In Figure 5, an exemplary system network 500 includes the

15 POS server 412, a representative docking station 422, two representative IR transmitters 434, a representative RF antenna 438, the RF audio transmitter 442, the IR exhibit server 444, the AV content server 452, the user profile database server 454, the content server 456, and the communications network 460, each connected and operating as described above with respect to Figure 4. Additionally, the exemplary system 500 includes an

20 administration workstation 510 coupled to the communications network 460, a backup generator 520 coupled to the docking station 422, and an optional RF LAN 530 coupled to the communications network 460. Also in the figure, a network router 540 is coupled between the communications network 460 and a fast communications (e.g., fast Ethernet) network 550. A library content server 555, a library workstation 560, and a WWW site

25 station 570 are coupled to the fast network 550.

In operation, the administration workstation 510 is used to access one or more of the servers 412, 444, 452, 454, 456 for purposes of system maintenance and diagnostics (note there may be one administrative workstation 510 for each of the various servers, or individual administrative workstations 510 can be used to access multiple servers). As

30 described above with respect to Figure 3, the optional RF LAN 530 can be used for data upload and download to and from the portable interface device 300 (e.g., without

requiring that the portable device 300 be docked in a docking station 422). In the system 500 of Figure 5, user profile data stored in the user profile database server 454 can be made available (e.g., via the network 460, or via the router 540 and the fast network 550) to various applications (as is described in detail below) in order to extend the visitor  
5 experience beyond the actual display facility. For example, the library workstation 560 can be made available to facility visitors (e.g., in an area proximate the display galleries) so that they can access the artifacts they selected during their visit and thereby obtain yet more detailed information relating to those artifacts (e.g., from the library content server 545). Additionally, visitors can, after having left the facility, access the selected artifacts  
10 via the WWW, as is indicated in Figure 5 by the WWW site station 570 (it will be appreciated that the WWW station 570 need not be connected directly to the fast network 550, but can be literally any computer connected to the WWW anywhere around the world).

The above described features of the invention are hereinafter illuminated by way  
15 of a description of a typical visitor walk through (e.g., a typical visitor experience within the facility 400 of Figure 4). Although a facility can be any one of a number of known facility types, the facility is, for ease of discussion, hereinafter presumed to be a museum displaying artifacts relating specifically to music (e.g., clothing and instruments previously belonging to well known musicians, video footage and static images of the  
20 musicians, etc.).

As the visitor enters such a music museum, docents positioned in the museum reception area can direct the visitor to purchase a ticket and check out a portable interface device. Additionally, a training video can be playing on video displays in the reception area to present the visitor with basic instructions for using the portable selection device  
25 in the music museum. Once the visitor has purchased a ticket and the sale is complete, the POS system prints out a uniquely barcoded ticket, and the portable interface device is checked out to the particular visitor (i.e., the visitor ticket ID is uploaded to the portable interface device ). From this time, and until the device is checked back in, the device records all visitor button presses and associates them with the unique visitor ticket ID.  
30 During the check out process, additional information can be exchanged with the portable interface device in order to personalize the device to the visitor, as is described in more

detail below.

As the visitor leaves the check out counter, a docent can direct the visitor to an orientation area in order to receive detailed instruction on wearing and operating the portable interface device. Upon completion of the presentation of instructions, the docent can further point out that the user selection device is displaying a starting, or home, museum page such as that shown in Figure 6A. The home page can be set up, for example, so that the user can select (via the numeric keys or the integral touch screen of the user selection device) additional instructions on device operation, or choose one of several available visitor programs for use in the museum (e.g., one visitor program might allow the user access to information on all exhibits, artifacts and galleries, while another visitor program might allow access only to information on artifacts related to a particular topic, such as jazz greats and their instruments).

As the visitor enters a gallery, the proximity loop located at the gallery entrance indicates such to the portable device. At that time, a gallery introduction audio clip (e.g., retrieved from the internal hard disk), a gallery specific background audio clip (e.g., received via the internal RF receiver from a proximate gallery transmit antenna), and/or a gallery specific LCD display page is presented to the visitor to properly welcome him or her to the gallery, and to reinforce proper use of the portable selection device in that space. As the introduction clip is played, the visitor can use the various keys on the user selection device to stop, pause, play, fast forward or fast rewind through the audio clip, just as with the familiar controls on conventional video and audio cassette recorders. The end of the introductory audio clip can be used to refresh the visitor on how to use the select key on the user selection device to select a particular exhibit (e.g., point at the symbol near the exhibit IR transmitter while simultaneously pressing the select key).

Once a particular exhibit is selected, the portable interface device begins to play back an exhibit specific introductory audio clip from the internal hard drive. The introductory audio clip presents information about the exhibit as a whole, and may give the majority of users all the information they desire regarding the entire exhibit. As the exhibit specific clip plays back, the visitor is able to use the transport keys on the portable selection device to stop, pause, play, fast forward and fast rewind through the clip.

During the playback of the exhibit introduction audio clip, the portable selection device display screen presents additional information options related to the exhibit. For example, in the context of a music museum, at least two groups of options can be presented to the visitor. A first group, referred to herein as liner notes, is a list of high-level audio clips that provide additional information on the exhibit as a whole (though more detailed than that presented in the exhibit introduction audio clip). Each selection in the liner note list has an associated number, and the user can enter the number on the portable selection device keypad, or by touching the item on the touch screen. Once a liner note is selected, a liner note audio clip is played back from the internal hard drive, and a corresponding text page is presented on the display screen of the portable selection device. Advantageously, liner note text pages can include links to related information about the exhibit. For example, a liner note can include an “if you like this, then you should check out . . .” type of statement which points the user to other exhibits in the museum or to upcoming events in the area. As a liner note clip plays back, the visitor can use the transport buttons on the portable selection device to stop, pause, play, fast forward or fast rewind.

A second group of options, referred to herein as artifact clips, is a list of audio clips associated with artifacts displayed in the exhibit. Such artifact audio clips give detailed information about the particular displayed artifacts. Each selection in the artifact clip list has an associated number which is displayed on the selection device display screen (see Figure 6B) and affixed to or adjacent the corresponding physical artifact in the exhibit. The user can enter the number via the selection device keypad or by touching the item on the display screen. Once an artifact clip is selected, the clip is played back from the internal hard drive, and an artifact text page associated with the artifact audio clip is presented on the selection device display screen. Like liner note text pages, each artifact text page can include a link to related information about the artifact. As an artifact audio clip plays back, the user is able to use the transport keys on the selection device to stop, pause, play, fast forward or fast rewind through the artifact audio clip.

In addition to physical artifacts, an exhibit can include one or more video displays. Such displays can, for example, present concert footage, musician interviews,

etc. According to exemplary embodiments, each of these video displays is treated like any other artifact. In other words, each video display has an identifier which is affixed adjacent to the display and made available via the selection device display screen. When the user enters the ID associated with a video display, the portable selection device tunes  
5 the internal RF audio receiver to an appropriate channel in order to pick up the associated audio via a nearby gallery transmit antenna.

With regard to retrieval of any of the above described information elements, it should be noted that content caching can be used, according to exemplary embodiments, to conserve battery life and to reduce playback delay (both objectives being achieved by  
10 reducing the number of times the hard drive is spun up for read access). For example, when the user makes an exhibit selection, the content and control device can begin caching applicable audio content into memory (e.g., for the presently selected exhibit and for nearby exhibits).

Advantageously, if the information provided by an exhibit, liner note, or artifact  
15 audio clip or text page is insufficient to satisfy the visitor, the visitor can use the bookmark key of the selection device to record the identification of the element of interest for later use outside the museum. For example, while an exhibit page, liner note text page or artifact text page is being presented to the user, the user can press the bookmark button to log the identification of the element the user wants more information  
20 about (along with, e.g., a time stamp, the visitor ticket ID, and any other pertinent data). Then, after completing the museum tour, the visitor can use the logged bookmarks as filters into the WWW, or into a workstation database located on the museum premises, to obtain even more detailed information related to the element of interest.

In addition to collecting bookmarks, the portable interface device can, as noted  
25 above, record literally every keystroke made by the visitor during his or her tour of the museum. Moreover, the portable interface device can be programmed to collect more directed input from the user (e.g., by asking questions such as "How did you like that exhibit?"). Following the visitor's tour of the museum, such keystroke and query information can be processed by the user profile database server to create usage reports  
30 for museum exhibits, to aid in marketing products associated with the museum, etc.

Once the visitor has completed his or her tour of the music museum, the visitor is

instructed to take the portable interface device to a return, or check in, station (e.g., in the reception area where the visitor originally purchased a ticket). At that time, the unique ticket ID stored within the portable interface device is read, the check out record is accessed via the POS server, and the user session is closed out for the particular portable  
5 interface device.

The information collected on the hard drive during the user's visit to the music museum (e.g., bookmarks, other keystrokes, answers to queries, etc.) is then downloaded to the user profile database server. More specifically, an application running on the user profile database server pulls the bookmarks from the portable interface device at docking.  
10 The bookmarks are stored, on the portable interface device and on the user profile database server, in a table including the unique user identifier (e.g., the ticket ID), the identifier for each element being bookmarked, and additional data such as time and date stamp information associated with the each bookmark action.

Once the bookmarks have been pulled to the user profile database, software  
15 interfaces allow other systems to read and utilize the bookmark records to extend the visitor experience beyond the actual museum tour. For example, workstations (e.g., the library workstation 560 of Figure 5) can be set up within the museum facility so that a visitor can use his or her downloaded bookmark information as a filter into more information about what is being displayed within the museum. Additionally, an interface  
20 between the user profile database server and the POS server can match bookmark information back to the ticket ID at the display facility so that an ongoing dialog can be established between the facility and its visitors based on the known likes of the visitors (e.g., concert mailings can be targeted to visitor groups sharing a common musical taste). Advantageously, the POS server can also use the bookmark information to tailor a  
25 portable interface device to a particular known user based on the user's previous selections. Moreover, a museum or third party web site can be tailored to aid further research related to recorded bookmarks. For example, visitors to such a site can use their ticket ID as a log in key, and the bookmarks can be linked to additional product or service information on the web.

30 Fig. 7 depicts steps in the above described exemplary method of capturing and utilizing bookmarks according to the invention. As shown, the method 700 begins at

step 710, and at step 720 the visitor ticket ID is uploaded to the portable interface device at device checkout. If the visitor is a known facility user (i.e., data already exists for the visitor in the user profile database), device operation can be tailored for the visitor based on past preferences at step 730. Thereafter, at step 740, the visitor's keystrokes and  
5 bookmarks are recorded and stored in the portable interface device throughout the duration of the user's visit to the facility. Upon the user's returning the portable interface device, the user's ticket ID and recorded keystrokes and bookmarks are downloaded at step 750, and the user profile database is updated at step 760. Thereafter, at step 770, the updated user profile database is made available to external applications which utilize the  
10 bookmarks to extend the visitor's past tour experiences (or to enhance subsequent tour experiences), and the process concludes at step 780.

Generally, the present invention provides audio, video, text and image presentation systems that allow visitors to display facilities or other public spaces to proactively select detailed information about the various items displayed in the facilities  
15 and other spaces. Through selection and bookmark functionality, exemplary systems provide a link between the elements in the display facility or other public space and additional, more detailed information delivered off-line via the WWW or in a fixed workstation environment within the display facility or public space itself. Consequently, the invention enables a visitor to self-guide and self-tailor his or her exploration of the  
20 display facility or other public space, and further enables the visitor to extend his or her experience beyond the display facility or other public space.

Those of skill in the art will appreciate that the above described embodiments are provided by way of illustration only, and that numerous equivalent embodiments are contemplated herein. Accordingly, the scope of the invention is not limited by the  
25 foregoing description, but is defined by the appended claims, including all equivalents thereof.

## WHAT IS CLAIMED IS:

1. A method for providing information about a public space element from a plurality of public space elements in a public space to a visitor after the visitor has left the public space, the method comprising:
  - transmitting electronically a first signal to a portable electronic device within the public space, the first signal associated with a location of the plurality of public space elements within the public space;
  - retrieving from the portable electronic device a selection menu that designates a first piece of information about the public space element from the plurality of public space elements;
  - receiving, from the portable electronic device within the public space, a second signal associated with the first piece of information about the public space element from the plurality of public space elements in response to a keystroke input by the visitor;
  - sending from the portable electronic device a third signal corresponding to the keystroke and a unique address associated with the visitor; and
  - sending electronically a fourth signal associated with a second piece of information about the public space element from the plurality of public space elements based on the sending the third signal, the fourth signal sent to the visitor after the visitor has left the public space via a communications network extending beyond the public space in response to an electronic request from the visitor after the visitor has left the public space.
2. The method of claim 1 wherein the keystroke includes one of a bookmark and a response to a query.
3. The method of claim 1 wherein the second signal further includes text content relating to the public space element.
4. The method of claim 1, wherein the second piece of information is more detailed than the first piece of information.

5. The method of claim 1, wherein:  
the keystroke is one of a plurality of keystrokes input by the visitor; and  
the sending from the first electronic device includes sending each keystroke  
from the plurality of keystrokes input by the visitor.

5

6. The method of claim 1, wherein the sending the third signal includes  
docking the portable electronic device within a docking station within the public space.

7. The method of claim 1, further comprising:  
10 tuning a receiver within the portable electronic device in response to the  
first signal.

8. A method for supplying information about an artifact in a museum to a  
visitor after the visitor has left the museum, the method comprising:  
15 receiving a first electronic request for information about the artifact from  
the visitor in the museum;  
transmitting electronically a first piece of information to the visitor in the  
museum in response to the first electronic request, the first piece of information including  
an audio portion transmitted by a first electronic device and a video portion transmitted by  
20 a second electronic device;  
receiving a second electronic request for information about the artifact from  
the visitor in the museum;  
associating visitor identification information with said second electronic  
request;  
25 receiving an electronic inquiry from the visitor after the visitor has left the  
museum; and  
sending, in response to the electronic inquiry, at least one of the audio  
portion of the first piece of information or the video portion of the first piece of  
information to the visitor after the visitor has left the museum based on the second  
30 electronic request associated with the visitor identification.

9. The method of claim 8, wherein said receiving the first electronic request  
includes receiving a wireless electronic signal generated from the first electronic device,

the first electronic device being a portable handheld device that traverses the museum with the visitor.

10. The method of claim 8, wherein said receiving the first electronic request  
5 includes receiving the wireless electronic signal over a first network having transmission capabilities limited to the museum.

11. The method of claim 8, wherein said receiving said electronic inquiry and  
said sending are executed over a second network different from said first network.

10

12. The method of claim 8, further comprising:  
sending, in response to the electronic inquiry, a second piece of information  
to the visitor after the visitor has left the museum based on the second electronic request  
associated with the visitor identification, the second piece of information different than the  
15 first piece of information.

13. A method for providing information about an artifact in a museum to a  
visitor after the visitor has left the museum, the method comprising:

20 receiving a first electronic signal within the museum, the first electronic  
signal associated with a location of a plurality of artifacts within the museum;

receiving a keystroke from a plurality of keystrokes input by a visitor  
within the museum;

25 transmitting, from a portable electronic device within the museum in  
response to the first electronic signal and the keystroke from the plurality of keystrokes, an  
audio signal associated with a first piece of information about an artifact from the plurality  
of artifacts;

30 receiving, from an electronic transmitter within the museum in response to  
the first electronic signal and the keystroke from the plurality of keystrokes, a video signal  
associated with the first piece of information about the artifact from the plurality of  
artifacts;

transmitting, from the portable electronic device within the museum, a  
second electronic signal corresponding to the keystroke and a unique address associated  
with the visitor; and

transmitting at least one of the audio signal or the video signal to the visitor after the visitor has left the museum based on the second electronic signal and in response to an electronic inquiry, via a communications network extending beyond the museum.

- 5           14.    The method of claim 13, further comprising:  
                  tuning automatically a receiver within the first electronic device in response to the receiving the first electronic signal.

**FIG. 1**

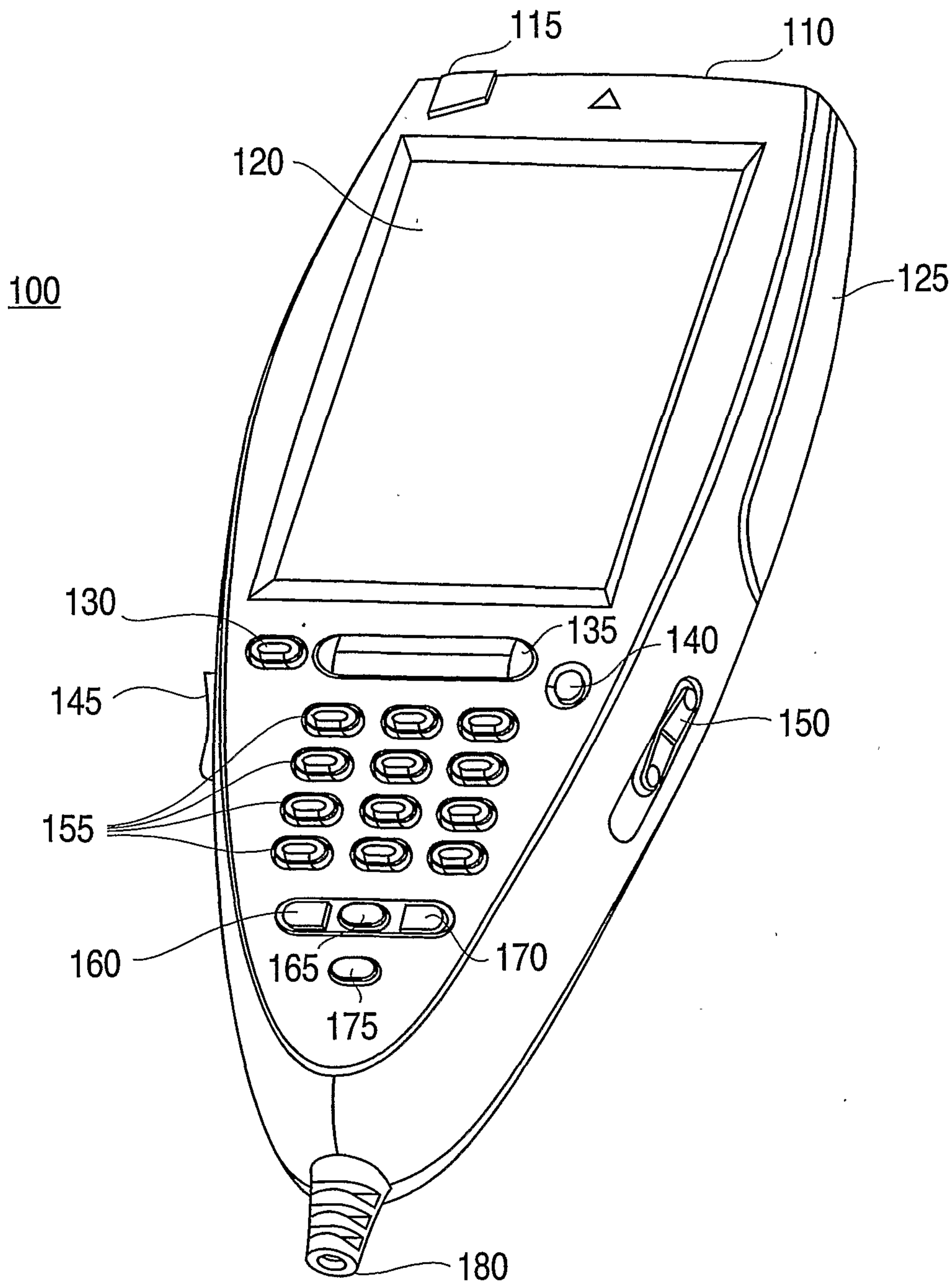

FIG. 2B

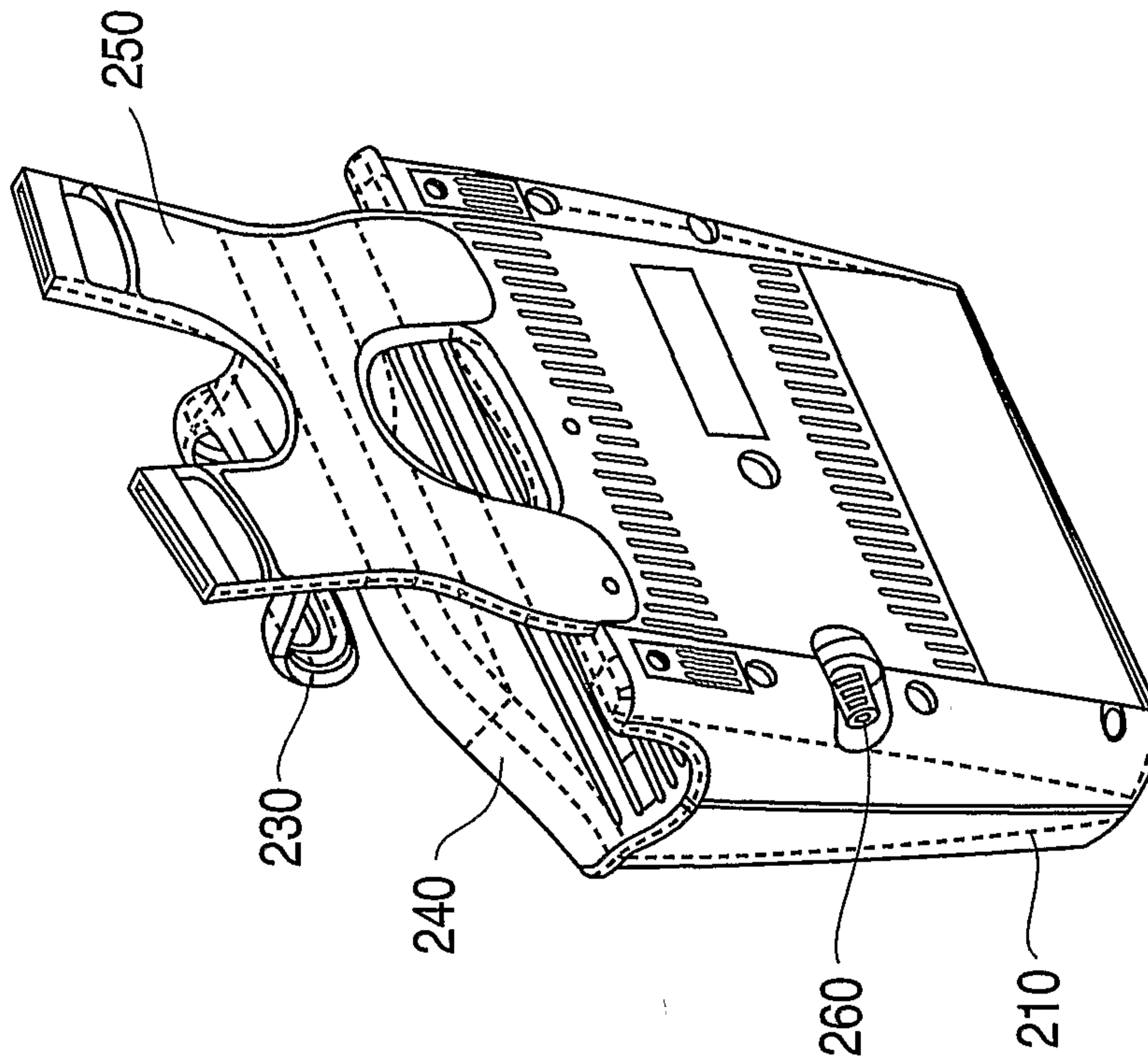
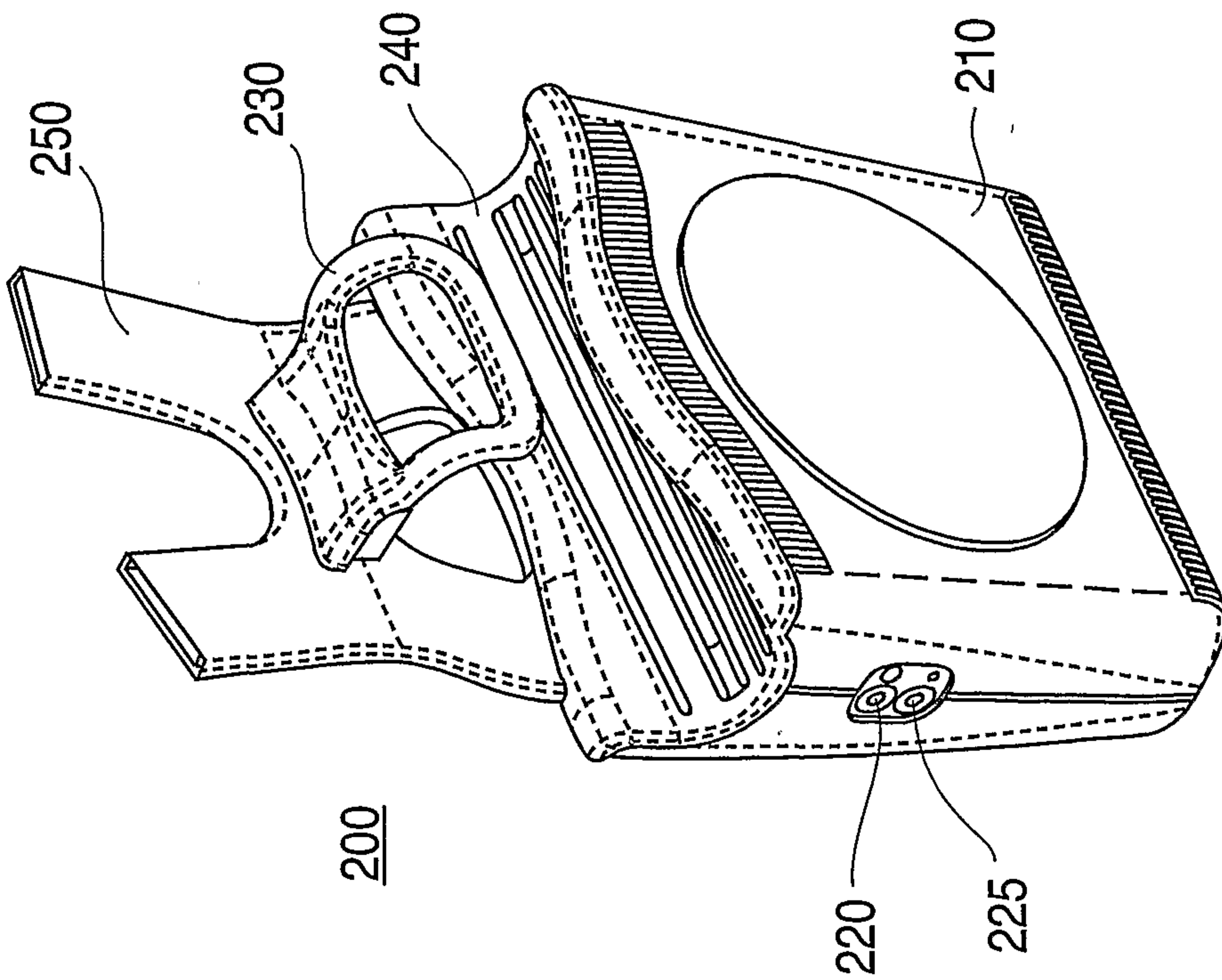

FIG. 2A



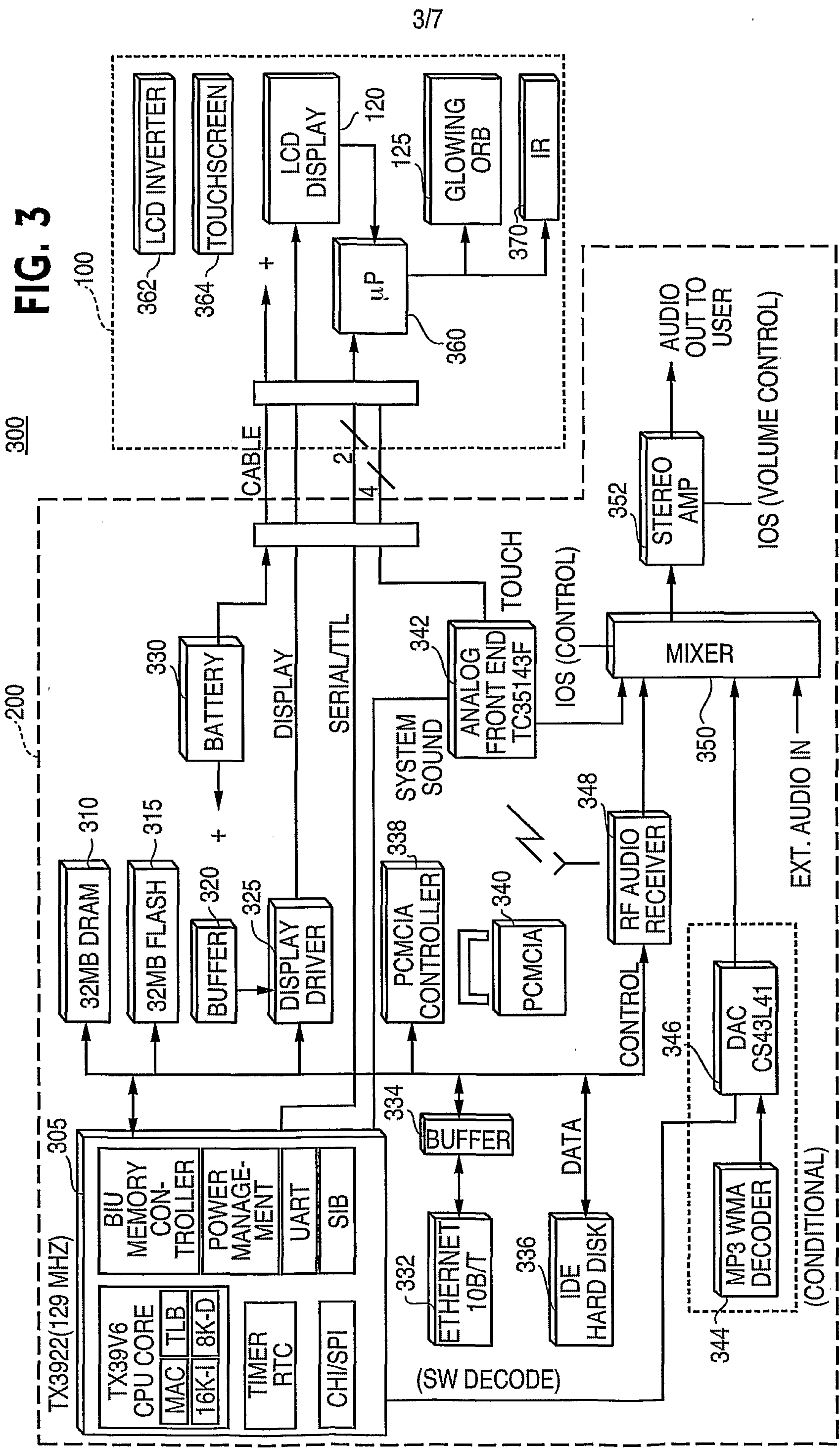

FIG. 4

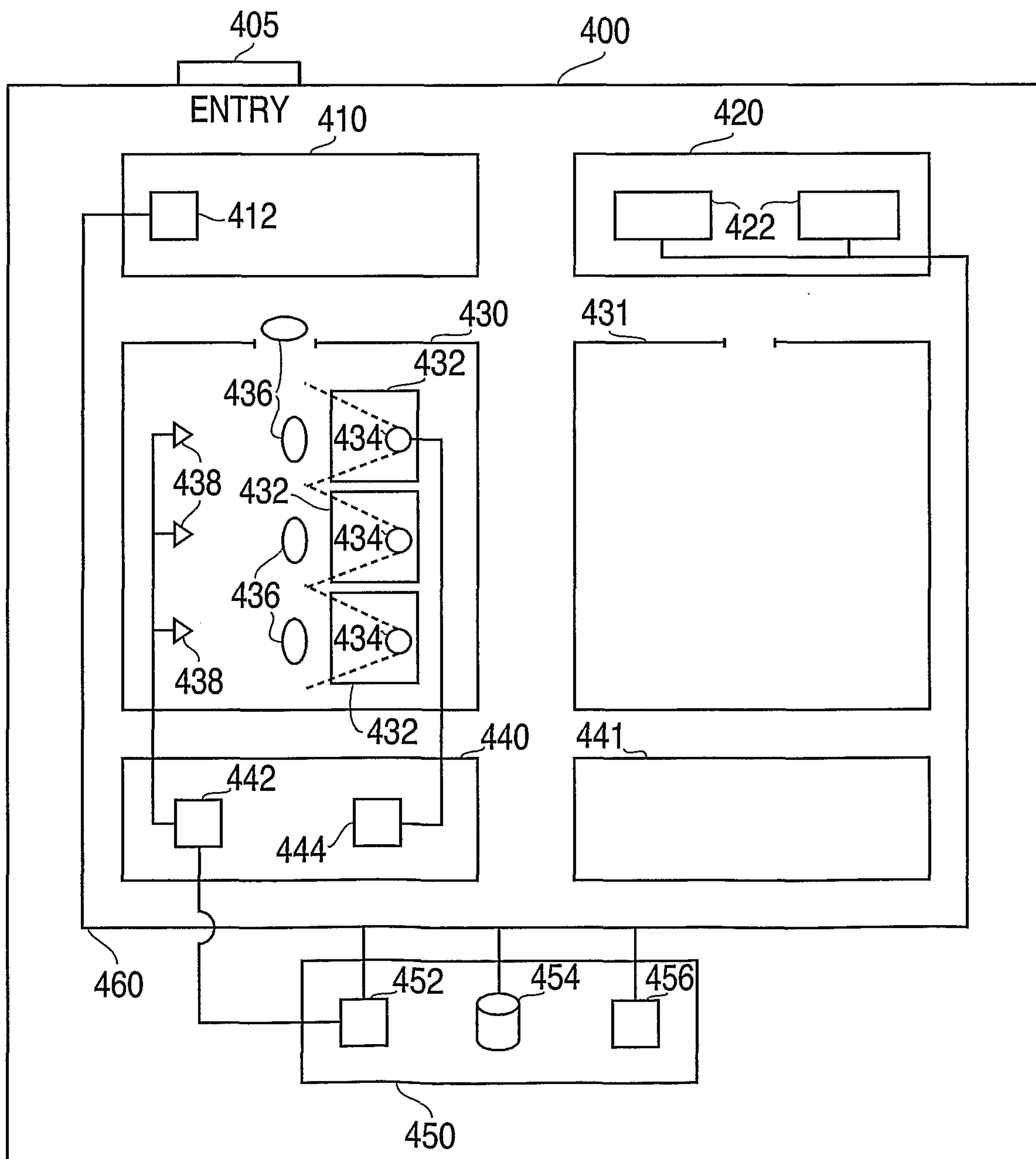
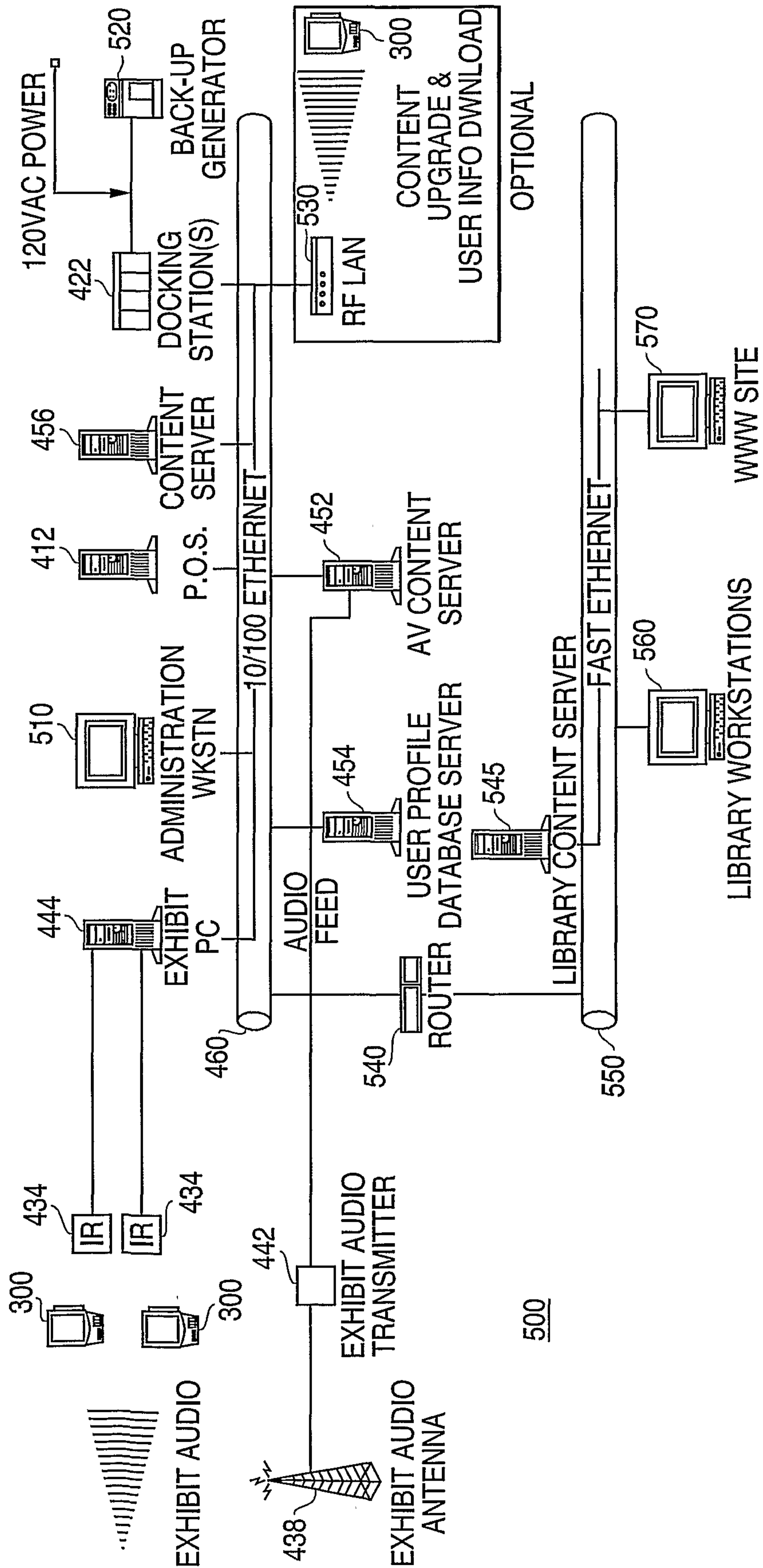
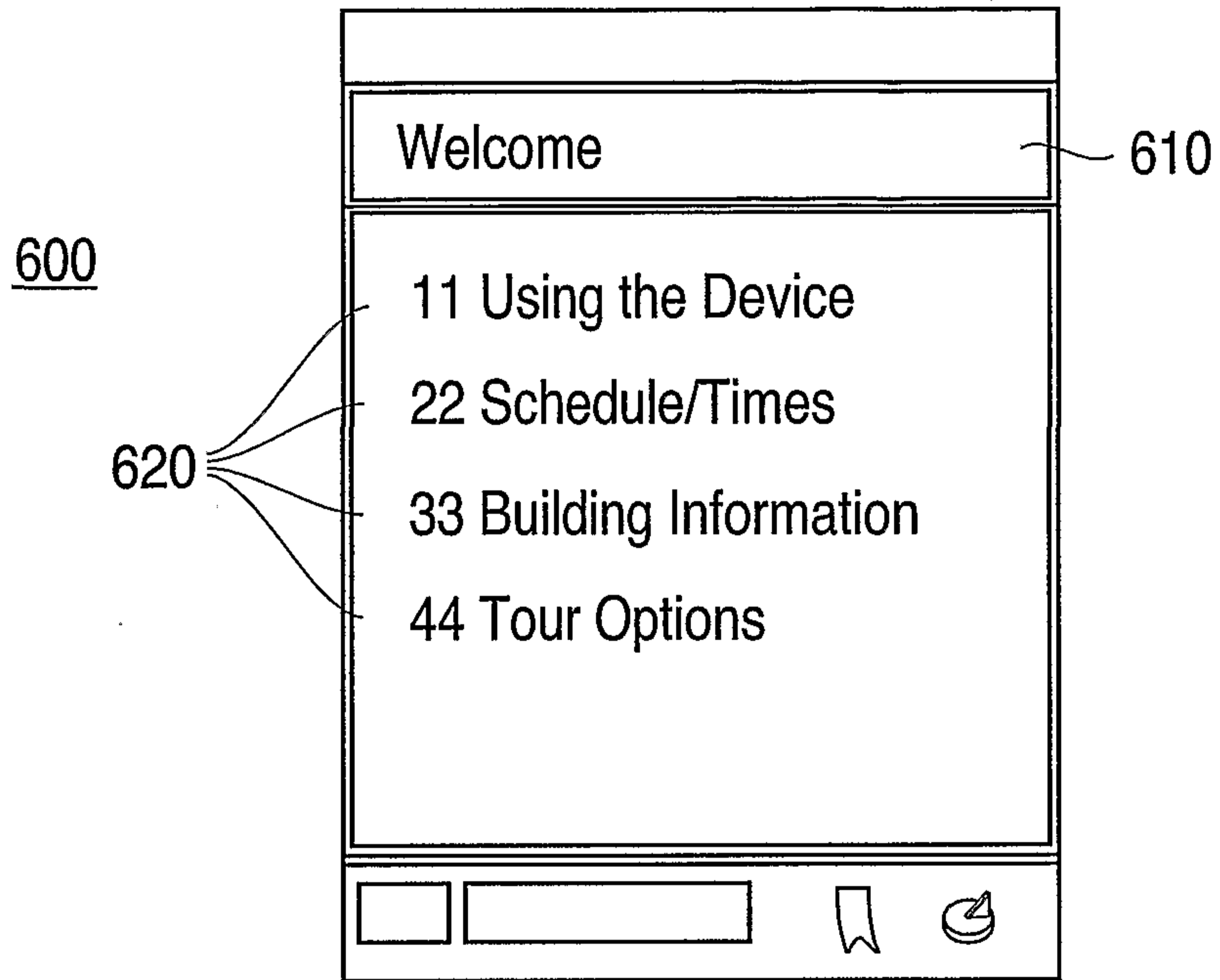

FIG. 5



**FIG. 6A**



**FIG. 6B**

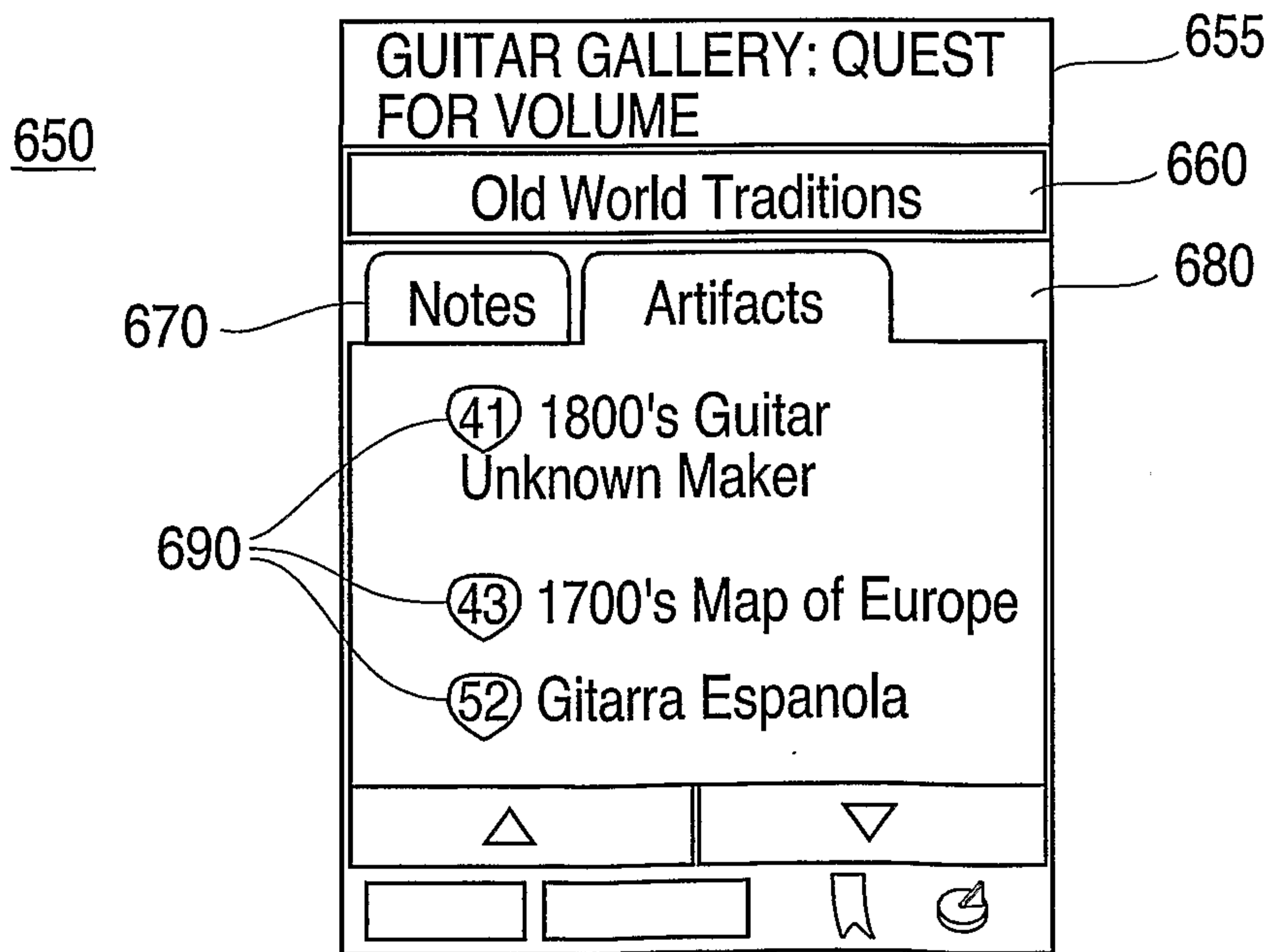

7/7

FIG. 7

