

M. GOEHLER.
 PROPELLING VANE FOR FLYING MACHINES.
 APPLICATION FILED JUNE 28, 1910.

997,804.

Patented July 11, 1911.

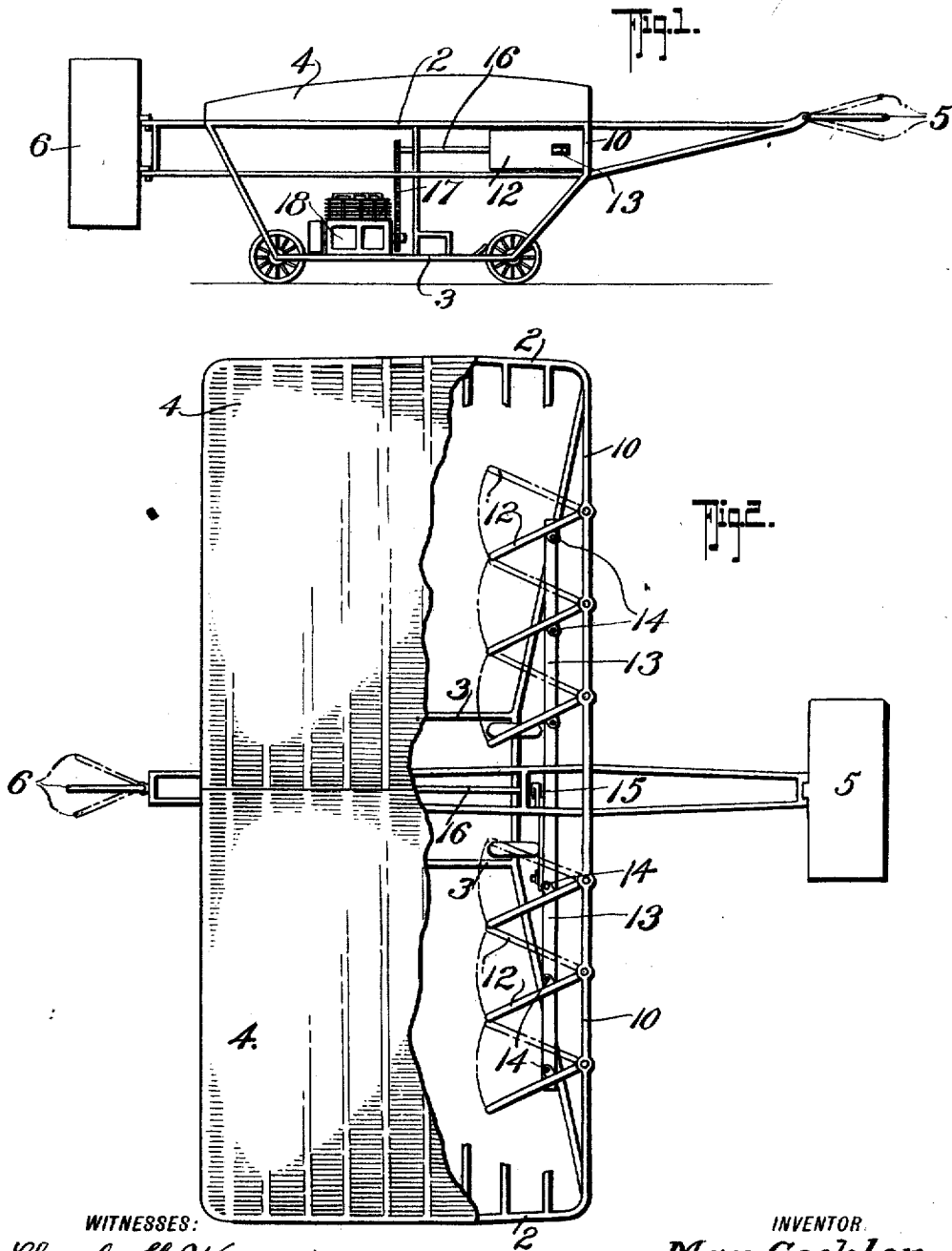

WITNESSES:
Charles H. Wagner.
John E. Schrott.

INVENTOR.
Max Goehler
 BY
Fred G. Dietrich & Co.
 ATTORNEYS.

UNITED STATES PATENT OFFICE.

MAX GOEHLER, OF VANCOUVER, BRITISH COLUMBIA, CANADA.

PROPELLING-VANE FOR FLYING-MACHINES.

997,804.

Specification of Letters Patent. Patented July 11, 1911.

Application filed June 28, 1910. Serial No. 569,288.

To all whom it may concern:

Be it known that I, MAX GOEHLER, citizen of the Republic of Switzerland, residing at Vancouver, in the Province of British Columbia, Canada, have invented a new and useful Propelling-Vane for Flying-Machines, of which the following is a specification.

This invention relates to a novel and improved means for propelling a flying machine of any kind, whether aeroplane or dirigible balloon.

The screw propeller seems to have been universally adopted as affording a simple and convenient means for applying the rotatory movement of an engine to effect the required object, but this device involves a loss of efficiency owing to the lessened velocity of the area of the blade toward the center of its rotation. This defect I propose to overcome in the invention which is the subject of this application by using a number of planes pivotally mounted toward the front end of the machine and oscillated on their pivots by a suitable mechanism from the driving engine.

The invention is particularly described in the following specification, reference being made to the drawings by which it is accompanied, in which:

Figure 1 is a side elevation of the machine, and Fig. 2, a plan and part section showing the propelling vanes.

In these drawings 2 represents the main frame of the machine and 3 a secondary frame beneath on which the engine and the seat of the aviator are carried, 4 being the sustaining vanes extending laterally outward from the main frame on each side. The elevating plane is represented by 5 and the lateral steering vane or rudder by 6.

Extending across the machine and forming the front edge of the sustaining vanes 4 is an open rectangular frame 10 and pivotally mounted in the upper and lower members of this frame are the oscillating vanes 12 by which the machine is to be driven, the free edges of the oscillating vanes being to-

ward the rear. These vanes 12 are oscillated from side to side through a definite angle by a light flat bar or bars 13 which bar passes through the vanes 12 and is pivotally connected at 14 to each. The bar 13 is endwise reciprocated to impart the desired oscillation to the vanes by a crank 15 secured on the end of a shaft 16 rotatable in bearings in the main frame of the machine by means of a chain 17 or by other suitable gearing from the engine 18 on the frame 3 beneath. The power of the engine is thus imparted to laterally oscillate the vanes 12 and the machine is driven forward by the reaction of the air on these vanes.

Having now particularly described my invention and the manner of its operation, I hereby declare that what I claim as new and desire to be protected in by Letters Patent, is:

1. In a flying machine, the combination with its framework, of an open rectangular frame extending across the machine, vanes the front edges of which are pivotally mounted in the top and bottom members of the open cross frame and means for connecting the body of the vanes to a bar extending lengthwise through them and laterally reciprocating from the propelling engine of the machine.

2. In a flying machine, the combination with its framework, of an open rectangular frame across the front of the machine, propelling vanes the front edges of which are pivotally mounted in the top and bottom members of the open cross frame, a horizontal bar passing through the vanes and pivotally connected with them and means for reciprocating this bar by a crank on a shaft driven from that of the engine.

In testimony whereof I have signed my name to this specification in the presence of two subscribing witnesses.

MAX GOEHLER.

Witnesses:

ROWLAND BRITAIN,
ALEXANDER SMITH.

Copies of this patent may be obtained for five cents each, by addressing the "Commissioner of Patents, Washington, D. C."