

(19) World Intellectual Property
Organization
International Bureau



(43) International Publication Date
20 October 2005 (20.10.2005)

PCT

(10) International Publication Number
WO 2005/096862 A2

- (51) International Patent Classification⁷: **A44B**
- (21) International Application Number:
PCT/IB2005/002140
- (22) International Filing Date: 2 March 2005 (02.03.2005)
- (25) Filing Language: English
- (26) Publication Language: English
- (30) Priority Data:
10/791,204 2 March 2004 (02.03.2004) US
- (71) Applicant (for all designated States except US): **VELCRO INDUSTRIES B.V.** [NL/NL]; Castorweg 22-24, Curaçao (AN).
- (72) Inventors; and
- (75) Inventors/Applicants (for US only): **LINE, Kevin, Keith** [CA/CA]; 80 Island 120 Severn River, Port Severn, Ontario (CA). **JANZEN, Daniel, Lee** [CA/CA]; 1003-11 Church Street West, Brampton, Ontario L6Y 4J7 (CA). **VOIGT, Paul, Joseph** [CA/CA]; 72 Niska Drive, Waterdown, Ontario L0R 2H3 (CA).
- (74) Agents: **RUTETZKI, Andreas** et al.; Müller-Boré & Partner, Grafinger Strasse 2, 81671 München (DE).
- (81) Designated States (unless otherwise indicated, for every kind of national protection available): AE, AG, AL, AM, AT, AU, AZ, BA, BB, BG, BR, BW, BY, BZ, CA, CH, CN, CO, CR, CU, CZ, DE, DK, DM, DZ, EC, EE, EG, ES, FI, GB, GD, GE, GH, GM, HR, HU, ID, IL, IN, IS, JP, KE, KG, KP, KR, KZ, LC, LK, LR, LS, LT, LU, LV, MA, MD, MG, MK, MN, MW, MX, MZ, NA, NI, NO, NZ, OM, PG, PH, PL, PT, RO, RU, SC, SD, SE, SG, SK, SL, SM, SY, TJ, TM, TN, TR, TT, TZ, UA, UG, US, UZ, VC, VN, YU, ZA, ZM, ZW.
- (84) Designated States (unless otherwise indicated, for every kind of regional protection available): ARIPO (BW, GH, GM, KE, LS, MW, MZ, NA, SD, SL, SZ, TZ, UG, ZM, ZW), Eurasian (AM, AZ, BY, KG, KZ, MD, RU, TJ, TM), European (AT, BE, BG, CH, CY, CZ, DE, DK, EE, ES, FI, FR, GB, GR, HU, IE, IS, IT, LT, LU, MC, NL, PL, PT, RO, SE, SI, SK, TR), OAPI (BF, BJ, CF, CG, CI, CM, GA, GN, GQ, GW, ML, MR, NE, SN, TD, TG).
- Published:**
— without international search report and to be republished upon receipt of that report
- For two-letter codes and other abbreviations, refer to the "Guidance Notes on Codes and Abbreviations" appearing at the beginning of each regular issue of the PCT Gazette.*

(54) Title: TOUCH FASTENER PRODUCTS

(57) Abstract: Touch fasteners (52, 100, 200, 300, 400, 500, 500a, 600, 800, 900) for use as mold inserts in molding seat foam buns (700) include selvages (24, 24a, 24b) that deflect under pressure to engage a mold surface (28, 28a) in face-to-face contact. Another touch fastener (52, 100, 200, 300, 400, 500, 500a, 600, 800, 900) includes a base (10, 10a, 10b) with an exposed thermally activatable resin (40, 40a) surface that has a softening point low enough to be activated by the exothermic foaming reaction to adhere the fastener (52, 100, 200, 300, 400, 500, 500a, 600, 800, 900) in the foam bun (700).

WO 2005/096862 A2

Touch Fastener Products

TECHNICAL FIELD

This invention relates to touch fastener products, and particularly to the use of touch fastener products as mold inserts, such as in the molding of seat foam buns and the like.

BACKGROUND

Seats for cars and light trucks have been formed by molding a foam bun that will serve as the seat cushion, and then attaching a pre-stitched fabric cover to the foam bun. Often, the fabric cover is attached to the foam bun by insert molding touch fastener products into the outer surface of the foam bun and attaching cooperating touch fastener products to an inner surface of the fabric cover. Generally, the fastener products are attached to the fabric cover along the seams where the cover is stitched together and held in place by the seam stitching. The touch fastener products allow the seat manufacturer to rapidly and semi-permanently attach the fabric cover to the foam bun by pulling the fabric cover over the foam bun and pressing the opposed touch fastener products on the foam bun and fabric cover together.

In general, the touch fastener products can be secured to the seat foam bun during a molding process, such as by holding the fastener products magnetically against a side of the mold cavity in which the foam bun is molded. During this molding process, care must be taken to avoid fouling of the fastener elements with the liquid foamable composition used to form the seat. Fouling can occur if the liquid foaming composition leaks between the edges of the base of the touch fastener product and the mold surface into the space between the fastener elements (e.g., hooks).

SUMMARY

In one aspect, the invention features a touch fastener product for use as a mold insert. The product includes a base having upper faces and lower faces and a central portion disposed between lateral selvages, the central portion having a nominal thickness, a magnetically attractable material secured to an upper face of the base; and a

plurality of fastener elements extending in an array from the lower face of the central portion of the base, wherein the selvages are of a significantly lesser stiffness than the stiffness of the central portion of the base, for flexure of the selvages to conform to a mold surface as the base of the fastener product is drawn against the mold surface by
5 magnetic attraction of the magnetically attractable material.

In some embodiments, the touch fastener is formed of a single contiguous resin.

In some embodiments, the central portion includes a strip of a first material supporting the fastener elements, and the selvages are formed of a second material of different composition than the first material. For example, the strip of first material can
10 have a surface integrally formed with stems of the fastener elements, or the selvages can include regions of a film secured to the upper face of the base. The film can be secured by an adhesive such as a polyamide hot melt. The film can have one or more of the following properties: the film can be a polyamide film, the film can have a softening point of between about 120 and 220 degrees Fahrenheit, the film can have a nominal
15 thickness of less than about 0.020 inch, for example about 0.010 inches or less, or about 0.005 inches or less, and the film can have a flexural rigidity of between about 1500 and 2000 mg-cm, e.g., about 1800 mg-cm.

In some embodiments, the nominal thickness of the central portion of the base is between about 0.002 and 0.012 inch.

20 In some embodiments, the nominal thickness of the central portion of the base is greater than a nominal thickness of the selvages.

In some embodiments, the magnetically attractable material includes a metal wire, a metal strip, or a coating of magnetically attractable particles.

25 In some embodiments, the magnetically attractable material is encapsulated in a hot melt adhesive.

In some embodiments, each selvedge extends from the array at least about 2 millimeters, for example each selvedge extends from the array at least about 4 millimeters.

30 In some embodiments, the selvages are of a material having a flexural rigidity of between about 1000 and 3000 mg-cm, e.g., about 1500 and 2000 mg-cm, preferably about 1800 mg-cm.

In some embodiments, selvages are disposed on all sides of the central portion of the base.

In some embodiments, the central portion of the base includes a molded resin.

5 In some embodiments, the fastener elements are male fastener elements. In some cases, the male fastener elements include stems integrally molded with the central portion of the base, the central portion of the base including a molded resin. In some cases, the male fastener elements have loop-engagable heads molded at distal ends of the stems. In some cases, the male fastener elements are hook-shaped.

10 In some embodiments, the fastener elements are arranged in a density of at least about 100 per square inch across the array.

In some embodiments, the fastener elements have an overall height, as measured normal to the base, of less than about 0.050 inch.

15 In another aspect, the invention features a method of forming a seat foam bun. The method includes providing a mold cavity having a shape corresponding to the shape of the seat foam bun, wherein the mold cavity includes a tapered trench having angled side walls, providing a touch fastener including a base, a plurality of fastener elements extending from a lower face of a central portion of the base in an array disposed between lateral selvages of the base, positioning the touch fastener along the trench with the selvages deflected from their unloaded position to extend along the trench side walls in face-to-face contact, and delivering a foamable resin into the mold cavity to form a seat foam bun, the deflected selvages resisting intrusion of foamable resin into the array of fastener elements.

20 In some embodiments, a lower face of the selvages has a substantially flat surface.

25 In some embodiments, the selvages are of a significantly lesser stiffness than a stiffness of the central portion of the base.

In some embodiments, the trench has flat side walls extending at acute angles (e.g., 5°, 10°, 15°, 20°, 25°, 30°, 35°, 40°, 45°, or 50°) from a bottom surface of the trench.

30 In some embodiments, the trench has curved side walls, the selvages conforming to arcuate surfaces of the trench side walls.

In some embodiments, in an unloaded condition, the selvages and central portion of the base lie in a common plane, the distal edges of the selvages deflected out of the common plane with the fastener positioned along the trench.

5 In some embodiments, the distal edges of the selvages contact the trench side walls with the fastener positioned along the trench.

In some embodiments, the selvages are disposed around all sides of the central portion of the base.

In some embodiments, the selvages comprise a film, for example a polyamide. In some cases, the film is adhered to the base, for example with a polyamide hot melt resin. In some cases, the film has a softening point between 120 and 220 degrees
10 Fahrenheit.

In some embodiments, the central portion of the base has a nominal thickness of between about 0.002 and 0.012 inch.

15 In some embodiments, the central portion of the base is thicker than the selvages.

In some embodiments, the touch fastener includes a magnetically attractable material. In some cases, the magnetically attractable material is disposed on the upper face of the central portion of the base. In some cases, the selvages are substantially free of magnetically attractable material. In some instances, the trench overlays a magnet.

20 In some embodiments, the trench is elongated, and the fastener product is in strip form. In some embodiments, the trench is a circular plateau and the fastener product is in circular form.

In some embodiments, the fastener elements are male fastener elements having stems integrally molded with a surface of the central portion of the base.

25 In some embodiments, the foamable resin comprises a polyurethane resin.

In another aspect, the invention features a seat foam bun. The seat foam bun includes a plateau disposed on a surface thereof, and positioned on the plateau is a touch fastener including a base and a plurality of fastener elements extending from a central portion of the base in an array disposed between selvages of the base, wherein the
30 selvages are embedded in the foam and extend about opposite upper side edges of the plateau.

In some embodiments, the selvages are lateral selvages.

In some embodiments, the plateau is an elongated plateau. In some embodiments, the plateau is a circular plateau.

5 In some embodiments, the selvages have a stiffness that is substantially less than a stiffness of the central portion of the base.

In some embodiments, the central portion of the base includes a resin.

In some embodiments, the selvages include a film.

In some embodiments, the film has a softening point between 120 and 220 degrees Fahrenheit.

10 In some embodiments, the film is adhered to the central portion of the base.

In some embodiments, the central portion of the base is thicker than the selvages.

In some embodiments, the selvages extend laterally beyond the central portion at least about 2 mm.

15 In some embodiments, the touch fastener includes a magnetically attractable material.

In some embodiments, a magnetically attractable material is disposed on the central portion of the base.

20 In some embodiments, an exposed surface of the selvages is substantially smooth.

In some embodiments, the foam is a polyurethane foam.

In another aspect, the invention features a touch fastener. The touch fastener includes a sheet-form base including an upper face and a lower face, a plurality of fastener elements disposed in an array on the lower face of the sheet-form base, a magnetically attractable material secured to the upper face of the sheet-form base, a film disposed on the upper face of the base, wherein the film has a softening point lower than about 220 degrees Fahrenheit.

In some embodiments, the softening point of the film is lower than about 180 degrees Fahrenheit, for example lower than about 150 degrees Fahrenheit.

30 In some embodiments, the film is between about 0.002 and 0.010 inch thick.

In some embodiments, the film includes a polyamide.

In some embodiments, the film is disposed over substantially the entire upper face of the base.

In some embodiments, the touch fastener also includes a material secured to the lower face of the base, wherein the material surrounds at least a portion of the array of fastener elements.

In some embodiments, the magnetically attractable material is a metal wire, or a coating of metal particles.

In some embodiments, the magnetically attractable material is disposed in a strip extending substantially an entire length of the touch fastener and substantially centered in a width of the touch fastener.

In some embodiments, the touch fastener also includes selvages extending laterally beyond the array of fastener elements, wherein the selvages include a substantially flat surface configured to engage a flat surface of a mold in face-to-face contact.

In some embodiments, the selvages are integrally molded with the base.

In some embodiments, the selvages includes a film disposed on the upper surface of the base.

In another aspect, the invention features a method of forming a seat foam bun. The method includes providing a mold cavity having a shape corresponding to a desired shape of the foam bun, positioning a touch fastener in the mold cavity, the touch fastener including a sheet-form base having an upper face and a lower face, a plurality of fastener elements disposed on the lower face of the sheet-form base, and a thermally-activatable resin exposed on the upper face of the sheet-form base; and delivering a foamable resin into the mold cavity causing the resin to foam in an exothermic reaction, wherein the reaction generates sufficient heat to activate at least an outer surface of the activatable resin to adhere the touch fastener to the foam.

In some embodiments, the foamable resin includes a polyurethane.

In some embodiments, the activatable resin is activated at a temperature between about 120 and 220 degrees Fahrenheit.

In some embodiments, the activatable resin comprises a film, for example a polyamide film.

In some embodiments, the resin is disposed over substantially the entire upper face of the base.

In some embodiments, the touch fastener includes a magnetically attractable material disposed on the upper face of the base.

5 In some embodiments, the magnetically attractable material is a metal wire laterally centered over the fastener elements.

In some embodiments, the touch fastener includes a material disposed on the lower face of the base, the material surrounding the plurality of fastener elements and forming a gasket between the base and a surface of the mold cavity.

10 In some embodiments, the touch fastener includes selvages extending laterally beyond the plurality of fastener elements.

In some embodiments, the selvages extend longitudinally beyond the plurality of fastener elements.

In some embodiments, the selvages are integrally molded with the base.

15 In some embodiments, the selvages include a film disposed on the upper surface of the base.

In some embodiments, the selvages include a smooth surface that engages a mold surface in face-to-face contact.

In another aspect, the invention features a touch fastener for use as a mold insert in which a molded surface can be formed. The touch fastener includes a sheet-form base including an upper face and a lower face, a plurality of fastener elements extending from the lower face of the sheet-form base disposed in an array, and a magnetically attractable material secured to the sheet-form base, wherein a portion of the sheet-form base extends laterally beyond the array of male fastener elements and forms selvages on opposite edges of the sheet-form base, the selvages being free of the magnetically attractable material, and having smooth, planar lower faces for engaging a flat mold surface in face-to-face contact on either side of the array to form a seal on either side of the array.

25 In some embodiments, the fastener elements are male fastener elements having stems integrally molded to the lower face of the sheet-form base.

30 In some embodiments, the magnetically attractable material includes a metal wire.

In some embodiments, each selvedge extends from the array at least about 2 mm.

In some embodiments, the width of the array of fastener elements is between about 2 mm and 10 mm.

In some embodiments, the length of the touch fastener is at least about 200 mm.

In some embodiments, the touch fastener also includes a material disposed on the
5 upper face of the sheet-form base.

In some embodiments, the touch fastener also includes a film disposed on the upper surface of the sheet-form base, wherein the softening point of the film is between about 140 and about 220 degrees Fahrenheit.

In another aspect, the method features a method of forming a seat form bun,
10 including the following steps: providing a mold cavity having a shape corresponding to a desired shape of the foam bun and defining a trench overlying a magnet, providing a touch fastener mold insert, the insert including a sheet-form base including an upper face and a lower face, a plurality of fastener elements extending from the lower face of the sheet-form base disposed in an array; and a magnetically attractable material secured to
15 the sheet-form base, a portion of the sheet-form base extending laterally beyond the array of male fastener elements and forming selvages on opposite edges of the sheet-form base, the selvages having smooth, planar lower faces, positioning the insert in the trench to establish a magnetic attraction between the attractable material and the magnet, thereby creating area contact pressure between the smooth, lower faces of the selvages
20 and mold surfaces on either side of the trench to form a seal; and delivering a foamable resin into the mold cavity to form a seat bun.

In some embodiments, the fastener elements are male fastener elements having stems integrally molded to the lower face of the sheet-form base.

In some embodiments, the foam is a polyurethane foam.

In some embodiments, the magnetically attractable material is encapsulated in a
25 polyamide hot melt composition.

In some embodiments, the magnetically attractable material includes a metal wire.

In some embodiments, the magnetically attractable material extends over
substantially the entire length of the touch fastener and is substantially centered over a
30 width of the touch fastener.

In some embodiments, the magnetically attractable material includes a coating of metal particles.

In some embodiments, the coating of metal particles is substantially centered over a width of the touch fastener.

5 In some embodiments, each selvedge extends from the array at least about 2 mm, for example, each selvedge can extend from the array at least about 4 mm.

In some embodiments, the width of the array of fastener elements is between about 2 mm and 10 mm.

In some embodiments, the length of the touch fastener is at least about 200 mm.

10 In some embodiments, sheet-form base is between about 0.002 inches and 0.012 inches thick.

In some embodiments, the method also includes a touch fastener having a material disposed on the upper face of the sheet-form base.

In some embodiments, the material is a woven material.

15 In some embodiments, the method also includes a touch fastener having a film disposed on the upper surface of the sheet-form base, wherein the softening point of the film is between about 140 and about 220 degrees Fahrenheit.

In some embodiments, the male fastener elements include molded hooks or mushroom shapes.

20 The term "stiffness" as used herein refers to the resistance of a sheet-form material to bend out of its plane when subjected to a normal bending force, and is synonymous with flexural rigidity.

At least some of the touch fasteners described herein can be used in molding processes without requiring a gasket to protect the fastener elements from being fouled with foam used to form the touch fastener (for example to form a gasket), thus reducing manufacturing costs. This can eliminate an additional manufacturing step of securing a separate material

25 In some aspects, the touch fastener products, when used in a molding process, can reduce the hindrance of the flow of foamable resin during the forming of a seat foam bun. For example, by having selvedges that lie flat in face-to-face contact with a mold surface, the selvedges create only a minor ridge. Accordingly, the foamable resin can pass over

the touch fastener without creating a significant disturbance in the flow of the resin (for example, as can occur when the advancing foamable resin meets an impediment), which can result in undesirable variations in foam density.

5 By molding a touch fastener into a plateau portion of a seat form bun, with selvedges of the fastener extending over the edges of the plateau, the touch fastener can have improved adhesion to the seat form bun and be more resistant to tear. The improved adhesion can result from conversion of at least some normal fastener separation load into a shear force between the angled selvedges and the foam.

10 In instances where the selvedges are formed of a material more flexible than the central portion of the touch fastener, the stress at the edges of the touch fasteners may be reduced. For example, in some instances the selvedges can bend more easily to maintain contact with the surface of the seat foam bun in instances where the seat foam bun is subjected to a compressing stress.

15 By providing a touch fastener with a back surface of a resin having a softening point near or lower than the reaction temperature during bun molding, the touch fastener can have improved adhesion to the seat form bun through heat activation of the exposed resin from the exothermic foaming reaction.

20 The details of one or more embodiments of the invention are set forth in the accompanying drawings and the description below. Other features, objects, and advantages of the invention will be apparent from the description and drawings, and from the claims.

DESCRIPTION OF DRAWINGS

FIG. 1 is a cross-sectional view of a touch fastener being positioned in a mold cavity.

25 FIG. 2 is a perspective view of a touch fastener having selvedges.

FIG. 3 is a cross-sectional view of a touch fastener having a material adhered thereto.

FIG. 4 is a cross-sectional view of a touch fastener having a coating of magnetically attractable material secured thereto.

FIG. 5 is a perspective view of a touch fastener having selvages of a film material.

FIG. 6 is a cross-sectional view of the touch fastener of Fig. 5 positioned in a trench of a mold cavity.

5 FIG. 6A is a cross-sectional view of another touch fastener positioned in a tapered trench.

FIGs. 7 and 8 are cross-sectional views of alternate touch fastener constructions.

FIG. 9 is a cross-sectional view of a seat foam bun, and FIG. 10 is an enlarged view of area 10 of FIG. 9.

10 FIG. 11 is a cross-sectional view of a touch fastener having a film adhered to the upper face of the sheet-form base.

FIG. 12 is a cross-sectional view of a touch fastener positioned in a mold trench during a foaming process.

15 FIG. 13 shows the touch fastener and trench of Fig. 12 upon completion of the foaming process.

The figures depicted herein are intended to aid the reader's understanding of various features of the invention disclosed herein. Accordingly, the drawings are for illustration only and are not necessarily drawn to scale. Like reference symbols in the various drawings indicate like elements.

20 DETAILED DESCRIPTION

In one aspect, the invention features a touch fastener 100 for use as a mold insert. Referring to Fig. 1, touch fastener 100 includes a sheet-form base 10 having an upper face 12 and a lower face 14. Fastener elements 16 extend from the lower face 14 of sheet-form base 10 in an array 20. A metal wire 18 is adhered with an adhesive 22 to the
25 upper face 12 of sheet-form base 10. Selvages 24 extend laterally from the sheet-form base 10 beyond either side of the array 20. Lower faces 26 of selvages 24 are smooth, planar surfaces, which can engage a flat mold surface 28 in face-to-face contact.

In some instances, as depicted in Fig. 1, a magnet 30 can be positioned in a mold 32 to position touch fastener 100 in a trench portion 34 of the flat mold surface 28. With
30 the fastener so positioned, a foamable liquid resin is poured into the mold cavity 27. An

exothermic reaction occurs, causing the liquid resin to foam up to fill the cavity. The foam adheres or is otherwise secured to the fastener, which becomes a part of the surface of the foam bun removed from the cavity.

Fig. 2 is a perspective view of touch fastener 100. Smooth, planar selvages 24 extend laterally beyond array 20 of male fastener elements 16. Methods of forming molded touch fasteners having stems or fastener elements extending integrally therefrom are well known in the art. For example, a continuous extrusion/roll-forming method for molding fastener elements on an integral, sheet-form base is described in detail in U.S. Patent No. 4,794,028 and in U.S. Pat. No. 4,775,310, the entire disclosures of which are incorporated herein by reference.

In some instances, the touch fastener product can be laminated to a mesh or scrim material. The scrim material can provide improved dimensional stability. Moreover, the scrim material can be magnetic (e.g., a ferrous-impregnated non-woven material), thus providing a magnetically attractable material as discussed above. Suitable examples of laminates are described in U.S. Patent No. 5,518,795 to Kennely et al. entitled LAMINATED HOOK FASTENER, the entire disclosure of which is incorporated herein by reference.

After a continuous length of touch fastener 100 is formed, it is cut to a defined length and then male fastener elements 16 are removed from opposite longitudinal ends of array 20 to provide flat portions 36 of the lower face 14 of sheet-form base 10. Alternatively, the fastener elements may be formed to be of such small size that they need not be removed from the longitudinal ends to effect sealing against foam intrusion across the fastener element array. A metal wire 18 is centered laterally over the array 20 of male fastener elements 16, and adhered to the upper face 12 of sheet-form base 10 with an adhesive 22, either before or after the base is cut to length.

In general, the array of touch fasteners is an array of hooks having a length of about 200 mm and a width of about 4 mm. The selvages each generally have widths of about 4 mm. The flat portions of the lower face of the sheet form base extend longitudinally beyond the fastener array about 4 mm. The sheet form base is constructed from a resin, such as a polyester, polypropylene, nylon, or other, and has a nominal thickness of about between about 0.002 and 0.020 inch, for example 0.005 inch.

An alternate embodiment of a touch fastener for use as a mold insert is depicted in Fig. 3. Touch fastener 200 includes a sheet-form base 10 having an upper face 12 and a lower face 14. A strip of magnetically attractable material 18a, such as iron, for example an iron wire, iron particles, steel, etc., is secured to the upper face 14 of the sheet-form base 12. Positioned over the magnetically attractable material 18a and secured on the upper face 12 of the sheet-form base 10, for example with an adhesive, is material 38, such as a woven or a non-woven material, or a knit of fiber, for example a cardboard or paper material. Alternatively, material 38 may be laminated directly to the molten resin of base 10 as the fastener element stems are molded, thereby encapsulating material 18a, using a combination of techniques taught by Kennedy et al (cited above) and Kenney et al. (United States Patent No. 5,945,193), the entire contents of which are hereby incorporated by reference. In some instances, material 38 provides improved adhesion of touch fastener 200 to a seat foam bun. Male fastener elements 16a are molded integrally with and extend from the lower face 14 of the sheet-form base 10 in an array 20. Selvedges 24 having smooth, planar lower faces 26 extend laterally beyond the array 20 of male fastener elements 16 and can engage in face-to-face contact with a flat mold surface.

In some instances, as depicted in Fig. 4, a touch fastener 300 can have adhered to an upper face 12 of a sheet-form base 10 a coating of magnetically attractable material 18b. In the configuration shown, selvedges 24 are substantially free of magnetically attractable material. In some other examples, the coating extends over the selvedges.

Referring to Fig. 5, touch fastener 400 includes a base portion 10 having an upper face 12 and a lower face 14. Male fastener elements 16, such as hooks, extend from the lower face 14 of the base 10 in an array 20. A magnetically attractable wire 18 is secured to the upper face 12 of the base 10 with an adhesive 22a. A film 40 is adhered to the upper face 12 of the base 10 by adhesive 22a and extends laterally beyond the base 10 to form selvedges 24a. The selvedges 24a have a stiffness that readily allows for flexure out of the plane of touch fastener 400, for example, under force of magnetic attraction. As shown in Fig. 5 the film extends longitudinally beyond the sheet form base, forming flat portions 36a that can engage a mold surface in face-to-face contact.

The base 10 has a length of about 200 mm and a width of about 4 mm. The sheet form base is constructed from a resin, such as polyester, polypropylene, or nylon, and has a nominal thickness of about 0.010 inch. The array of fastener elements 20 extends over substantially the entire lower face 14 of the base 10. The film extends about 4 mm
5 laterally beyond the base 10 and about 4 mm longitudinally beyond the base 10. The film is a polyamide film and has a nominal thickness of 0.005 inch. The fastener elements 16 are hooks positioned in alternating rows of hooks facing in opposing directions. Although a polyamide film is described in the present embodiment, other films could also be used, including polyurethane or other adhesive films.

10 Fig. 6 depicts a cross-sectional view of touch fastener 400 positioned in a mold 32a. A magnet 30a is positioned below a trench 34a portion of the mold, where the trench 34a has angled side portions 42. The side portions 42 are generally positioned in an acute angle from the bottom surface of the trench, for example, 5°, 10°, 15°, 20°, 25°, 30°, 35°, 40°, 45°, 50°, or 55°. The force of magnetic attraction between magnet 30a and
15 metal wire 18 holds touch fastener 400 in position against the surface of the mold trench 34a during foaming. During the molding process, selvages 24a engage mold surface 28a in face-to-face contact to prevent fouling of fastener elements 16. Contact pressure between the selvages and the mold wall is a function of the magnetic force applied to the wire 18, and the bending stiffness of the film 40.

20 Fig. 6A shows another example of a tapered trench, this one having arcuate side walls that extend upward from the bottom of the trench. The film 40 is of such a width that lateral edges of the film are deflected upward as the central portion of the fastener is drawn against the bottom of the trench. The illustrated fastener 600 includes a thin strip of magnetically attractable metal 18a, instead of a wire, disposed within the central
25 portion of the strip-form product. Metal 18a may be in the form of a shim, for example, and may be perforated, and expanded to form holes through its thickness for improved resin adhesion. Strip 18a may be bonded to resin of base 10a as the base is formed, or adhered thereto by adhesive, such as adhesive binding film 40 to base 10a.

The touch fastener 500 of Fig. 7 is identical in structure to the one shown in Fig.
30 5, except that wire 18 is disposed on an opposite side of film 40, and held in place by a

discrete bead of hot melt polyamide 22. Film 40 may be bonded to base 10 with adhesive 22a as shown, or directly laminated to the resin of the hook base.

The touch fastener of 500a of Fig. 8 is similar in structure to the touch fasteners of Figs. 5 and 7, except that touch fastener 500a is a single, unitary structure constructed of a resin material. The base portion 10b is integrally molded with selvages 24b such that the nominal thickness of the base portion is greater than the nominal thickness of the selvages. Like touch fastener 500, the wire 18 is adhered to the upper face of base 10b with adhesive 22.

In some instances, the touch fasteners are molded into a seat foam bun, for example as depicted in Figs. 9 and 10. Molded seat foam bun 700, depicted in Fig. 9, includes a trench portion 44, which includes a plateau 46 having lateral edges 48 and angled side walls 50. A touch fastener 52 is molded into plateau 46 and extends across lateral edges 48 and along a portion of angled sides 50, such that the distal edges 51 of the fastener are disposed out of the plane of the fastener element array, and directed toward into the bun. Touch fastener 52 includes a base 10 portion having an upper face 12 and a lower face 14. Extending from the lower face 14 are male fastener elements 16 having stems integrally molded thereto. A magnetically attractable strip 18a is adhered to the upper face 12 of the base 10 and a film 40 covers magnetically attractable strip 18a and expands beyond the lateral edges of the base 10 to form selvages 24a. The selvages 24a are molded into the seat foam bun 700, creating a smooth surface on the lateral edges 48 and angled side 50 walls of the plateau 46.

In general, the extension of selvages 24a down side walls 50 can provide strong adherence between touch fastener 52 and seat foam bun 700 and improved resistance to delamination. For example, when upward force "F" is applied to touch fastener 52, at least a portion of that upward force is resisted by a shear force "S" between angled selvages 24a underlying foam and helping to prevent cracks from forming between touch fastener 52 and seat foam bun 700, which can lead to dislocation of touch fastener 700.

While Seat cushion foam pads are flexible, it is desirable to mold rigid fasteners onto the surfaces of foam pads. When a rigid part is attached to the foam there can be

areas of high stress concentration along the edges of the rigid part. In use, foam pads can tear along the rigid fasteners if the foam is worked around the rigid part.

The flexible film edges described in Figs. 9 and 10 can move with the foam and can allow forces to be transferred gradually into the fastener component. The flexible
5 can also edges resist crack propagation between the fastener and the foam and provide minimal stress risers.

Tension forces that build up in the strip fastener as it holds the upholstery down can be spread out evenly over the inner portions of the fastener (rigid hook) and reduced rapidly at the edges. The result is that the forces of foam adhesion along the outer most
10 edges of the film can be reduced. Where there is little force there will generally be little inclination to tear. Most of the forces are central in the fastener where edge cracking and failure propagation is not likely to occur.

For use in a tapered trench as shown in Figs. 6 or 6A, the selvages 24a of the fastener product preferably are of a bending stiffness or flexural rigidity sufficiently low
15 to enable the selvages to be deflected into face-to-face contact with the side walls of the trench, and to allow the attractable magnetic forces to pull the central portion of the fastener product into planar contact with the bottom of the trench across the entire hook array. However, the selvedge bending stiffness should also be high enough to maintain a contact pressure between the selvages and mold surface, preferably even along the
20 lateral edges of the selvages during the foaming process. For many applications employing typical mold magnets and reasonable trench widths, a selvedge material having a flexural rigidity of between about 1000 and 3000 gm-cm, as measured in accordance with the Cantilever Test option of ASTM D1388, should be suitable. However, different applications may require varying the selvedge stiffness to optimize
25 results. For example, while film has been described as suitable selvedge material, other materials can also be used to form selvages, including paper or other fibrous material, rubber, cotton, or horse hair.

As depicted in Fig. 11, touch fastener 800 includes a sheet-form base 10 with an upper face 12 and a lower face 14. Fastener elements 16 extend in an array 20 from
30 lower face 14 of sheet-form base 10. A film 40a is secured to upper face 12 of sheet-form base 10. A metal wire 18 is secured with an adhesive 22 to film 40a.

Touch fastener 800 is particularly useful as a mold insert for the forming of a seat form bun. In particular, film 40a has a softening point low enough that the heat produced by the exothermic foaming reaction of bun molding at least partially activates the exposed surface of the film; physically adhering the fastener to the foaming resin.

5 Adherence may be due to the softened film becoming activated to provide an improved adhesion of the foam to the film, or may be by chemical bonding of the film and foam.

Fig. 11 also illustrates a gasket material 54 positioned around the array of fastener elements 16, such that when touch fastener 800 is positioned against a flat mold surface 55, material 54 forms a seal against the mold surface during the foaming process, acting as a barrier to protect fastener elements 16 from foam intrusion. The sealing of the 10 gasket formed between material 54 and the mold surface is aided by a magnetically attractable force between metal wire 18 and a magnet (not shown) positioned below the mold surface.

Fig. 12 depicts touch fastener 900 positioned over a trench 34 of a mold 32 during a foaming process. Touch fastener 900 includes a sheet-form base 10 having an upper 15 face 12 and a lower face 14. Lower face 14 includes male fastener elements 16 with stems integrally molded thereto. Upper face 12 includes a magnetically attractable strip of material 18a positioned above the male fastener elements 16. Film 40a is positioned over magnetically attractable strip of material 18a and adhered to the upper face 12 of the 20 sheet-form base 10. The sheet-form base 10 extends laterally beyond the male fastener elements 16 and engages a smooth mold surface 28a in face-to-face contact, providing a barrier that prevents the foamable resin 56 from fouling fastener elements 16.

During the bun molding process, foamable resin 56 is added the mold 32. The foamable resin 56 reacts in an exothermic manner, producing heat as it forms into a solid 25 seat foam bun. The foaming reaction may advance across the touch fastener 900, first encountering only the edge of the selvedge, which is thin enough to not impede expansion of the foam across the mold surface. Moreover, the smooth surface also aids the expansion of the foam across the surface. As the foaming reaction proceeds across the exposed film, the temperature of the film surface nears its softening point and 30 becomes physically adhered to the foam 58, either by mechanical or chemical bonding enhanced by the thermal attraction of the film. Although described as a film, thermally-

activatable resin may be provided as an exposed surface of fastener 900, as a coating, as discrete beads or ribs, or other form.

Any of the fastener products discussed above may also be provided with protrusions or other fasteners on its back surface, which are shaped to become embedded
5 in the foam of the seat bun to mechanically lock the fastener into the bun.

Examples of suitable thermally activatable resins that can be provided as films or in other forms include polyamides, polyurethanes, and other hot melt adhesives.

A number of embodiments of the invention have been described. Nevertheless, it will be understood that various modifications may be made without departing from the
10 spirit and scope of the invention.

Accordingly, other embodiments are within the scope of the following claims.

WHAT IS CLAIMED IS:

1. A touch fastener product (52,100,200,300,400,500,500a,600,800,900) for use as a mold insert, the product comprising;
- 5 a base (10,10a,10b) having upper faces (12) and lower faces (14) and a central portion disposed between lateral selvages (24,24a,24b), the central portion having a nominal thickness;
- a magnetically attractable material (18,18a,18b) secured to an upper face (12) of the base (10,10a,10b); and
- 10 a plurality of fastener elements (16,16a) extending in an array (20) from the lower face (12) of the central portion of the base;
- wherein the selvages (24,24a,24b) are of a significantly lesser stiffness than the stiffness of the central portion of the base (10,10a,10b), for flexure of the selvages (24,24a,24b) to conform to a mold surface (28,28a) as the base (10,10a,10b) of the fastener product (52,100,200,300,400,500,500a,600,800,900) is drawn against the
- 15 mold surface (28,28a) by magnetic attraction (30,30a) of the magnetically attractable material (18,18a,18b).
2. The touch fastener of claim 1 wherein the touch fastener (52,100,200,300,400,500,500a,600,800,900) is formed of a single contiguous resin.
- 20
3. The touch fastener of claim 1 or 2 wherein the central portion comprises a strip of a first material supporting the fastener elements (16,16a), and wherein the selvages (24,24a,24b) are formed of a second material (40,40a) of different composition than the first material; in particular, the strip of first material has a surface integrally
- 25 formed with stems of the fastener elements (16,16a); or the selvages (24,24a,24b) comprise regions of a film (40,40a), such as a polyamide film, secured to the upper face (12) of the base (10,10a,10b); the film (40,40a) can be secured by an adhesive (22,22a) such as a polyamide hot melt; particular, the film (40,40a) has one or more of the following properties, film (40,40a) has a softening point of between about 48 and 105
- 30 degrees Celsius, film (40,40a) has a nominal thickness of less than about 0.508

millimeter, for example, less than about 0.025 millimeter; film (40,40a) has a flexural rigidity of about 1800 mg-cm, or film (40,40a) has a tensile stiffness of between about 1000 and about 3000 mg-cm.

5 4. The touch fastener of any of claims 1-3 wherein the nominal thickness of the central portion of the base (10,10a,10b) is between about 50 and 305 microns or is greater than a nominal thickness of the selvages (24,24a,24b).

10 5. The touch fastener of any of the preceding claims wherein the magnetically attractable material (18,18a,18b) comprises a metal wire, or a metal strip, or a coating of magnetically attractable particles, or the magnetically attractable material (18,18a,18b) is encapsulated in a hot melt adhesive.

15 6. The touch fastener of any of the preceding claims wherein each selvage (24,24a,24b) extends from the array at least about 2 millimeters, for example at least about 4 millimeters; or the selvages (24,24a,24b) are of a material having a flexural rigidity of between about 1000 and 3000 mg-cm, or the selvages (24,24a,24b) are disposed on all sides of the central portion of the base (10,10a,10b).

20 7. The touch fastener of any of the preceding claims wherein the central portion of the base (10,10a,10b) comprises a molded resin.

25 8. The touch fastener of claim any of the preceding claims wherein the fastener elements (16,16a) are male fastener elements, for example, wherein the male fastener elements (16,16a) comprise stems integrally molded with the central portion of the base (10,10a,10b), the central portion of the base (10,10a,10b) comprising a molded resin; or wherein the male fastener elements have loop-engagable heads molded at distal ends of the stems, or wherein the male fastener elements (16,16a) are hook-shaped; or the fastener elements (16,16a) are arranged in a density of at least about 15.5 per square
30 centimeter across the array (20); or the fastener elements (16,16a) having an overall height, as measured normal to the base (10,10a,10b), of less than about 0.127 centimeter.

9. A method of forming a seat foam bun (700) comprising;
providing a mold cavity (27) having a shape corresponding to the shape of
the seat foam bun (700), wherein the mold cavity (27) comprises a tapered trench
5 (34,34a) having angled side walls (50);
providing a touch fastener (52,100,200,300,400,500,500a,600,800,900)
comprising a base (10,10a,10b), a plurality of fastener elements (16,16a) extending from
a lower face (14) of a central portion of the base in an array (20) disposed between lateral
selvedges (24,24a,24b) of the base (10,10a,10b);
10 positioning the touch fastener (52,100,200,300,400,500,500a,600,800,900)
along the trench (34,34a,44) with the selvedges (24,24a,24b) deflected from their
unloaded position to extend along the trench (34,34a,44) side walls (50) in face-to-face
contact; and
delivering a foamable resin (58) into the mold cavity (27) to form a seat
15 foam bun (700), the deflected selvedges (24,24a,24b) resisting intrusion of foamable
resin (58) into the array (20) of fastener elements (16,16a,16b).

10. The method of claim 9 wherein a lower face (26) of the selvedges
(24,24a,24b) has a substantially flat surface, or wherein the selvedges (24,24a,24b) are of
20 a significantly lesser stiffness than a stiffness of the central portion of the base
(10,10a,10b).

11. The method of any of claims 9 or 10 wherein the trench (34,34a,44) has
flat side walls (42) extending at acute angles from a bottom surface of the trench or the
25 trench (34,34a,44) has curved side walls (42), the selvedges (24,24a,24b) conforming to
arcuate surfaces of the trench side walls (42).

12. The method of any of claims 9-11 wherein in an unloaded condition, the
selvedges (24,24a,24b) and central portion of the base (10,10a,10b) lie in a common
30 plane, the distal edges of the selvedges (24,24a,24b) deflected out of the common plane
with the fastener (52,100,200,300,400,500,500a,600,800,900) positioned along the trench

(34,34a,44), for example the distal edges of the selvages (24,24a,24b) contacting the trench side walls (42) with the fastener (52,100,200,300,400,500,500a,600,800,900) positioned along the trench (34,34a,44); or wherein the selvages (24,24a,24b) are disposed around all sides of the central portion of the base (10,10a,10b).

5

13. The method of any of claims 9-12 wherein the selvages (24,24a,24b) comprise a film (40,40a), for example a polyamide film; or wherein the film (40,40a) is adhered to the base (10,10a,10b), for example, wherein the film (40,40a) is adhered to the base (40,40a) with a polyamide hot melt resin (22,22a); or wherein the film (40,40a) has a softening point between 48 and 105 degrees Celsius.

10

14. The method of any of claims 9-13 wherein the central portion of the base (10,10a,10b) has a nominal thickness of between about 50 and 305 microns, or the central portion of the base (10,10a,10b) is thicker than the selvages (24,24a,24b).

15

15. The method of claim 9-14 wherein the touch fastener (52,100,200,300,400,500,500a,600,800,900) includes a magnetically attractable material (18,18a,18b), for example, wherein the magnetically attractable material (18,18a,18b) is disposed on the upper face (12) of the central portion of the base (10,10a,10b), or wherein the selvages (24,24a,24b) are substantially free of magnetically attractable material (18,18a,18b), or wherein the trench (34,34a) overlays a magnet (30,30a).

20

16. The method of any of claims 9-15 wherein the trench (34,34a) is elongated, and the fastener product (52,100,200,300,400,500,500a,600,800,900) is in strip form.

25

17. The method of any of claims 9-16 wherein the fastener elements (16,16a) are male fastener elements having stems integrally molded with a surface of the central portion of the base (10,10a,10b), or wherein the foamable resin (56) comprises a polyurethane resin.

30

18. A seat foam bun (700) comprising:
a foam bun having a plateau (46) disposed on a surface thereof, and
positioned on the plateau (46), a touch fastener
(52,100,200,300,400,500,500a,600,800,900) comprising a base (10,10a,10b) and a
5 plurality of fastener elements (16,16a) extending from a central portion of the base
(10,10a,10b) in an array (20) disposed between selvages (24,24a,24b) of the base
(10,10a,10b), wherein the selvages (24,24a,24b) are embedded in the foam (58) and
extend about opposite upper side edges of the plateau (46).
- 10 19. The seat foam bun of claim 18 wherein the selvages (24,24a,24b) are
lateral selvages, or wherein the selvages (24,24a,24b) have a stiffness that is
substantially less than a stiffness of the central portion of the base (10,10a,10b), or
wherein the selvages (24,24a,24b) comprise a film (40,40a), for example, wherein the
film (40,40a) has a softening point between 48 and 105 degrees Celsius, or wherein the
15 film (40,40a) is adhered to the central portion of the base (10,10a,10b); or wherein the
central portion of the base (10,10a,10b) is thicker than the selvages (24,24a,24b), or
wherein the selvages (24,24a,24b) extend laterally beyond the central portion at least
about 2 mm.
- 20 20. The seat foam bun of any of claims 18 or 19 wherein the plateau (46) is an
elongated plateau.
21. The seat foam bun of any of claims 18-20 wherein central portion of the
base (10,10a,10b) comprises a resin.
- 25 22. The seat form bun of any of claims 18-21 wherein the touch fastener
(52,100,200,300,400,500,500a,600,800,900) includes a magnetically attractable material
(18,18a,18b), for example, wherein a magnetically attractable material (18,18a,18b) is
disposed on the central portion of the base (10,10a,10b).

30

23. The seat foam bun of any of claims 18-22 wherein an exposed surface of the selvages (24,24a,24b) is substantially smooth.

24. The seat foam bun of any of claims 18-23 wherein the foam (58) is a
5 polyurethane foam.

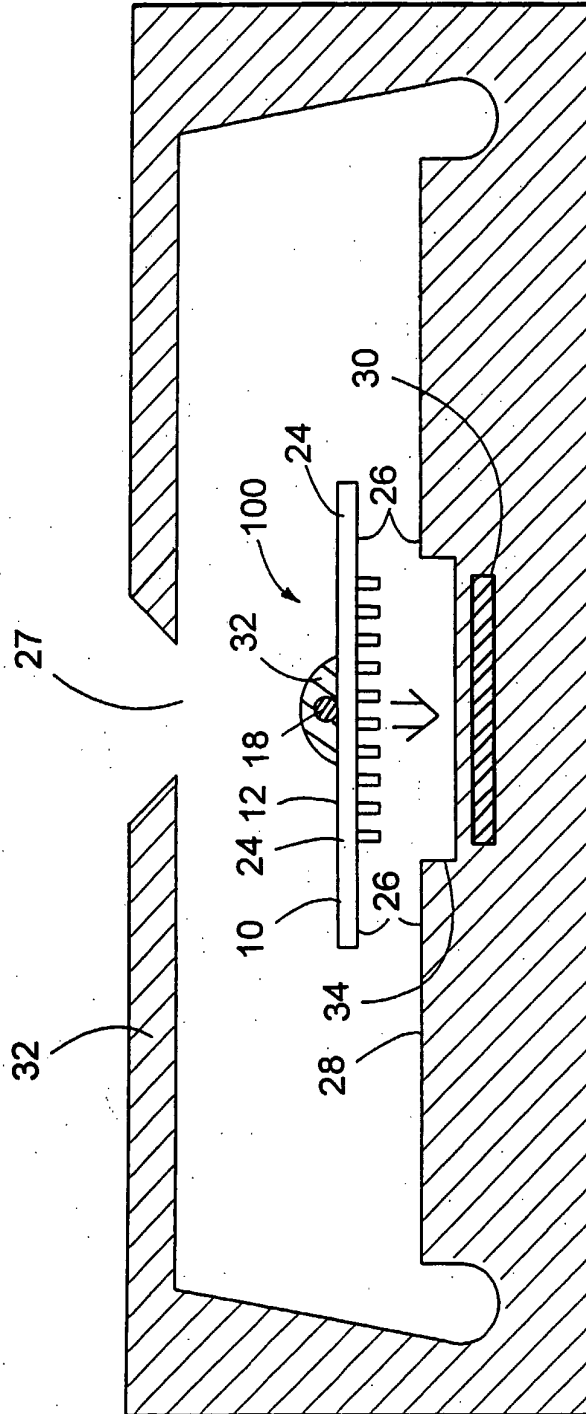

FIG. 1

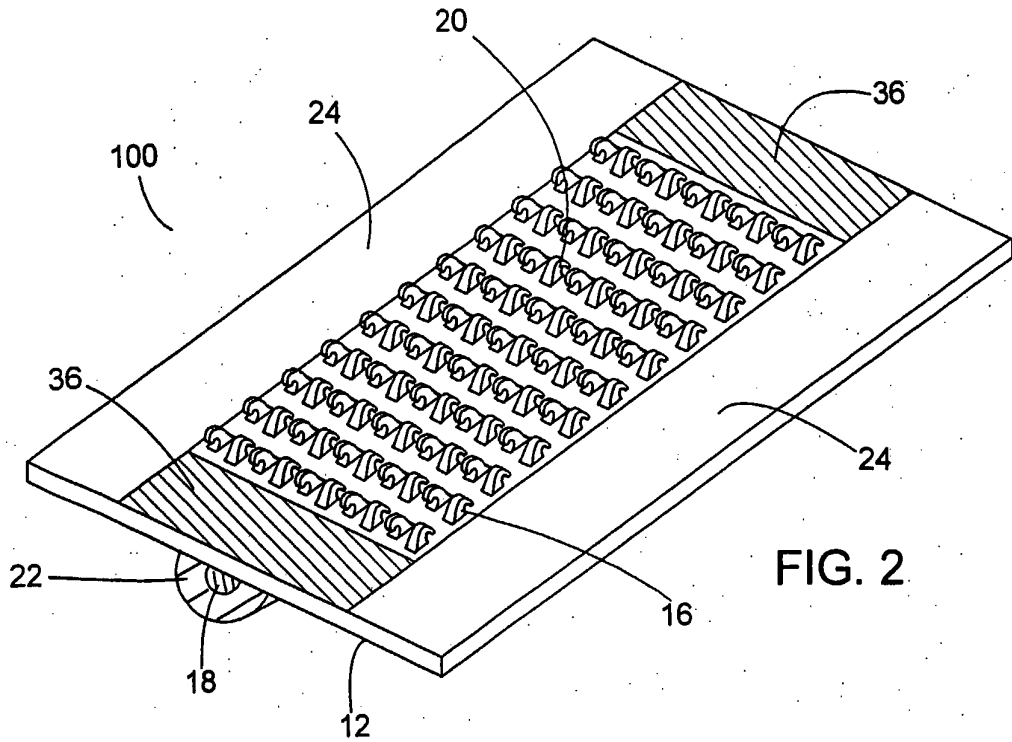

FIG. 2

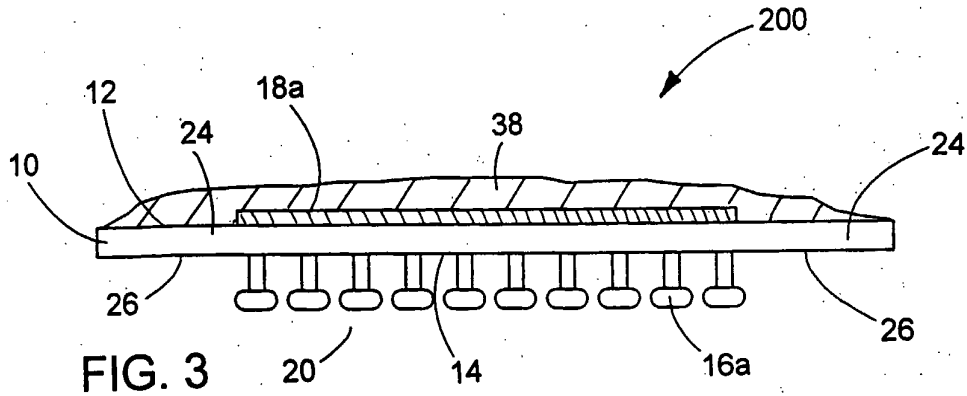

FIG. 3

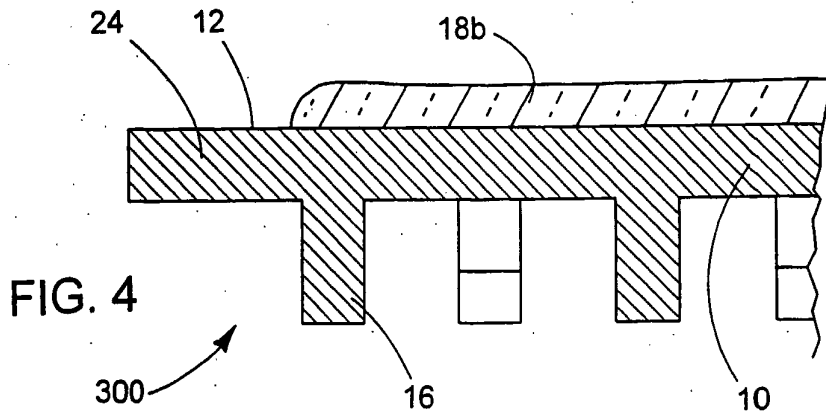
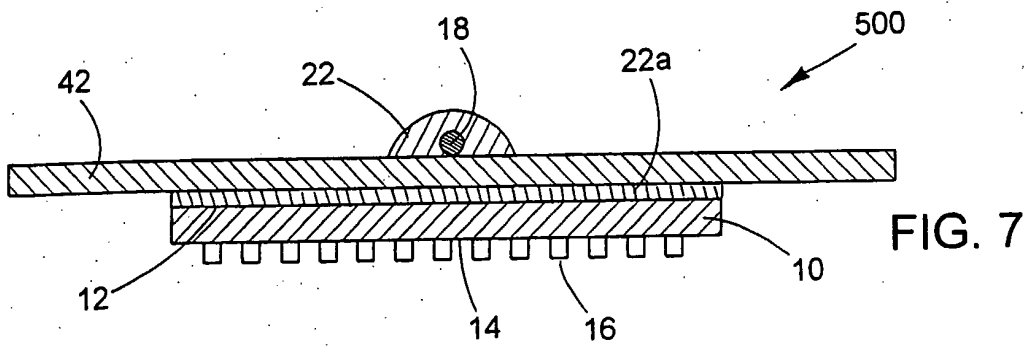
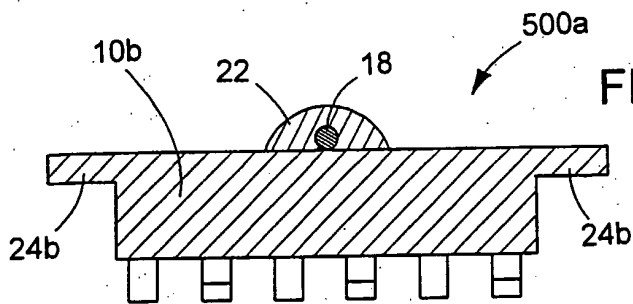
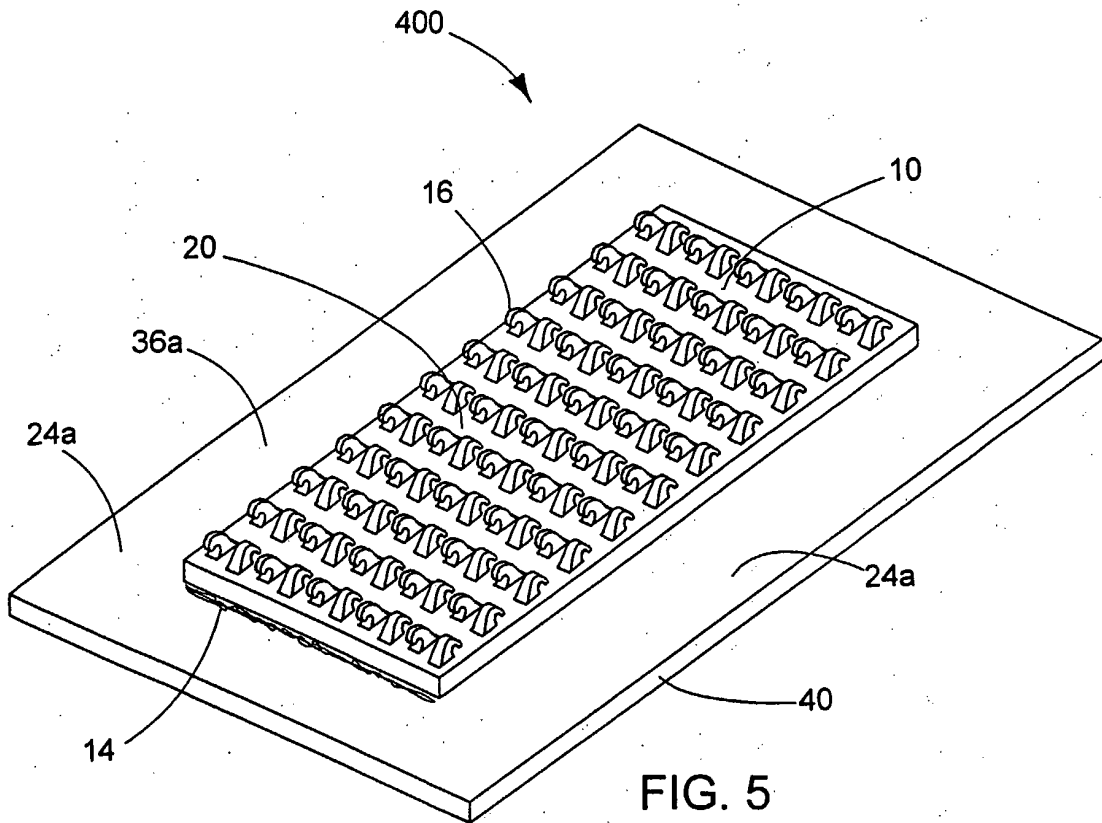

FIG. 4



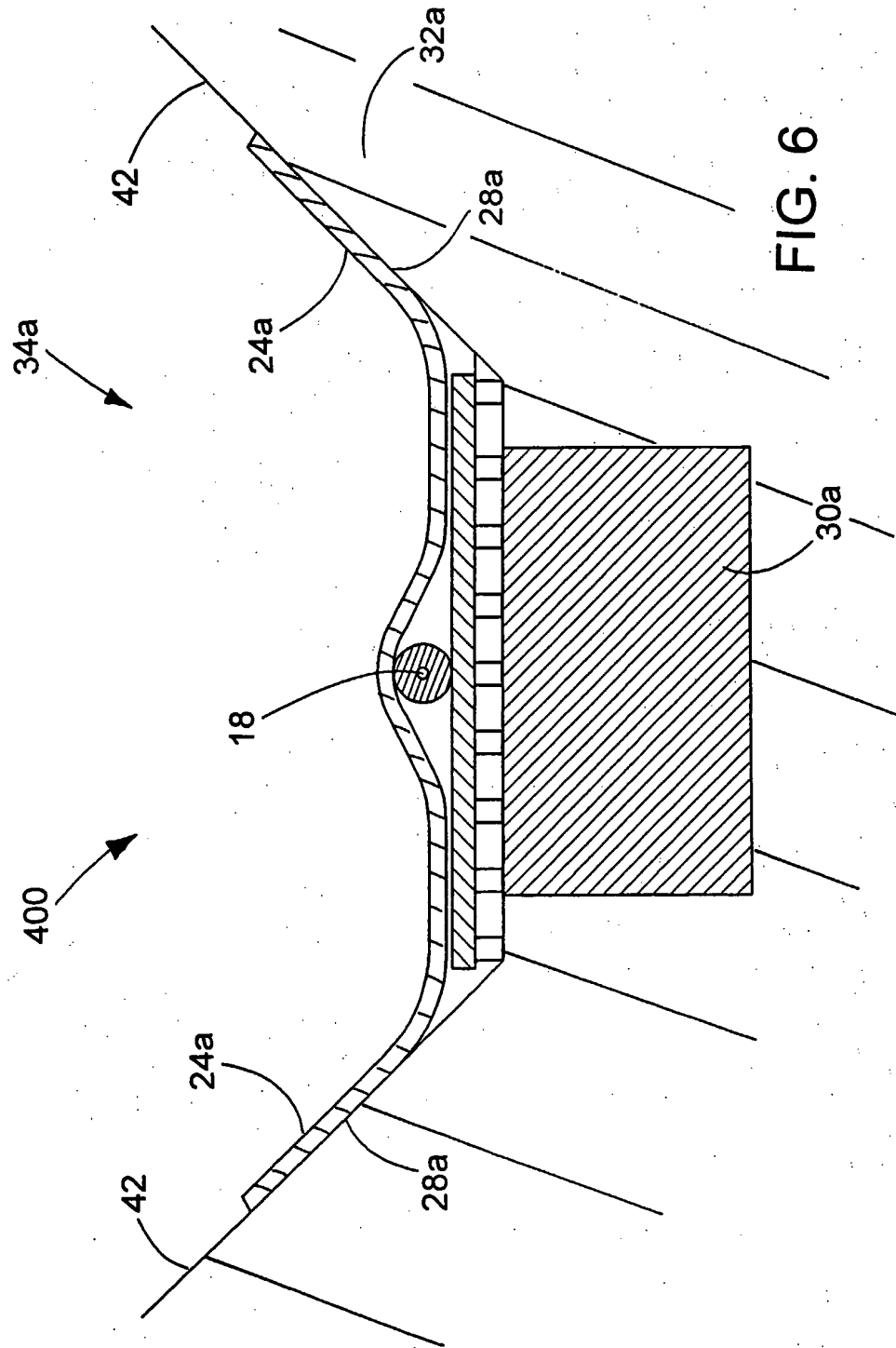

FIG. 6

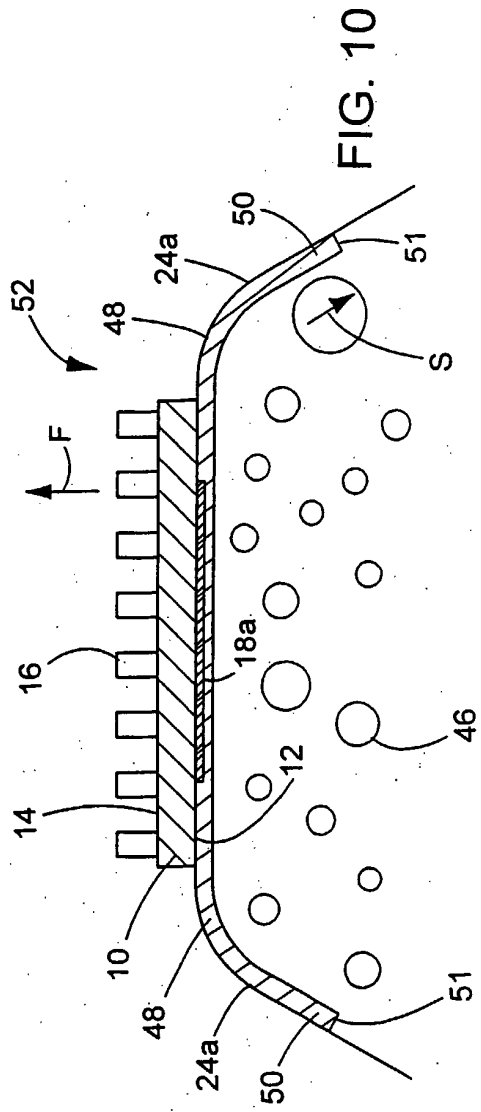

FIG. 10

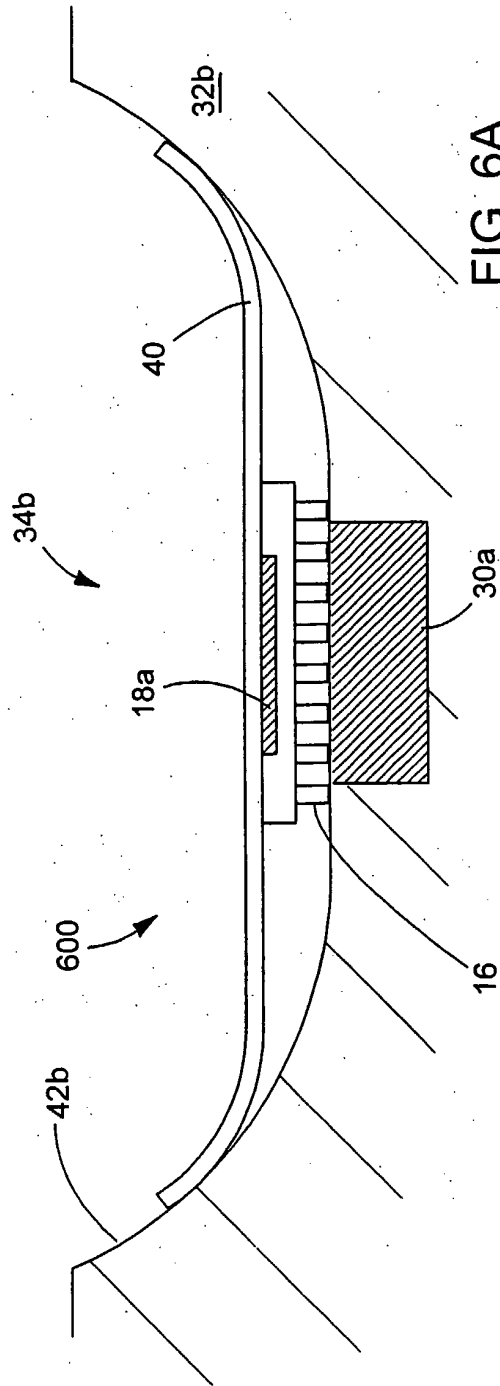
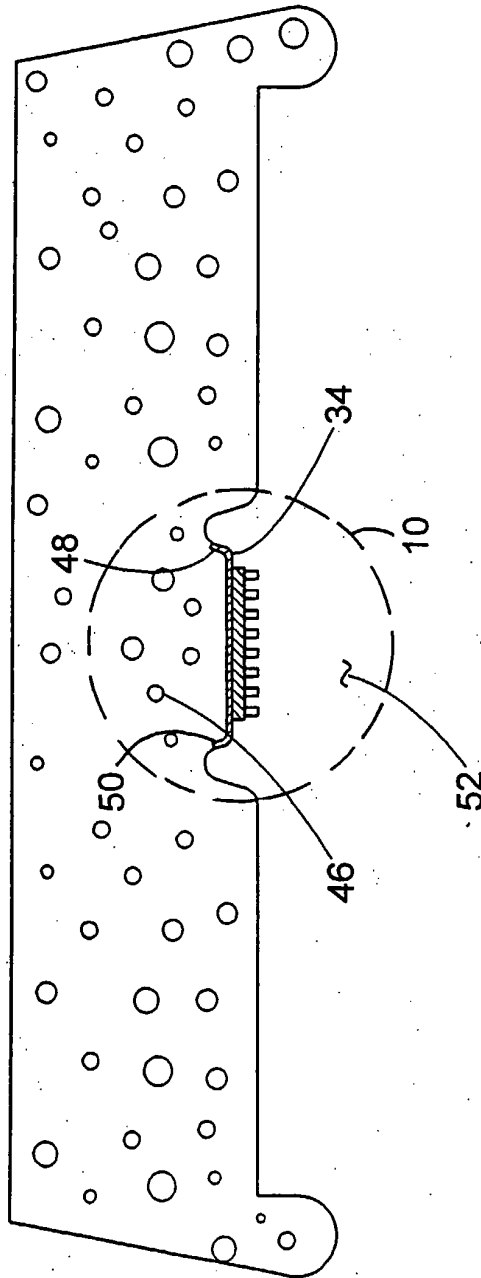

FIG. 6A

FIG. 9



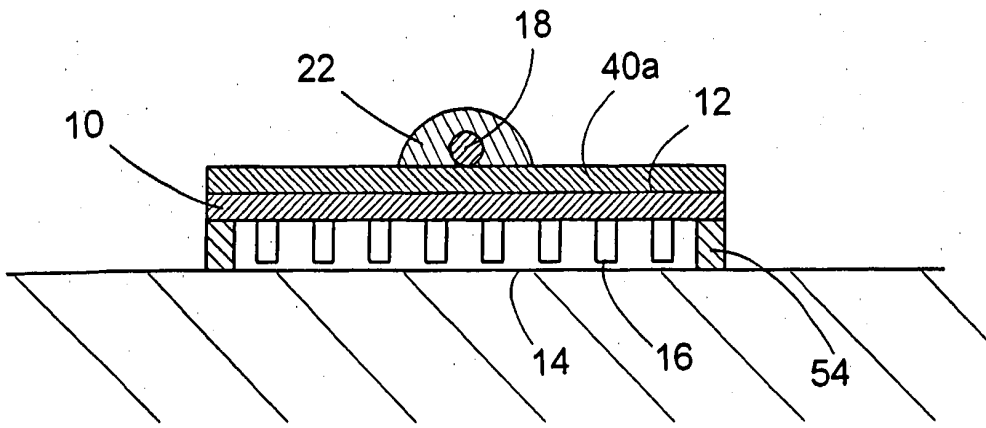

FIG. 11

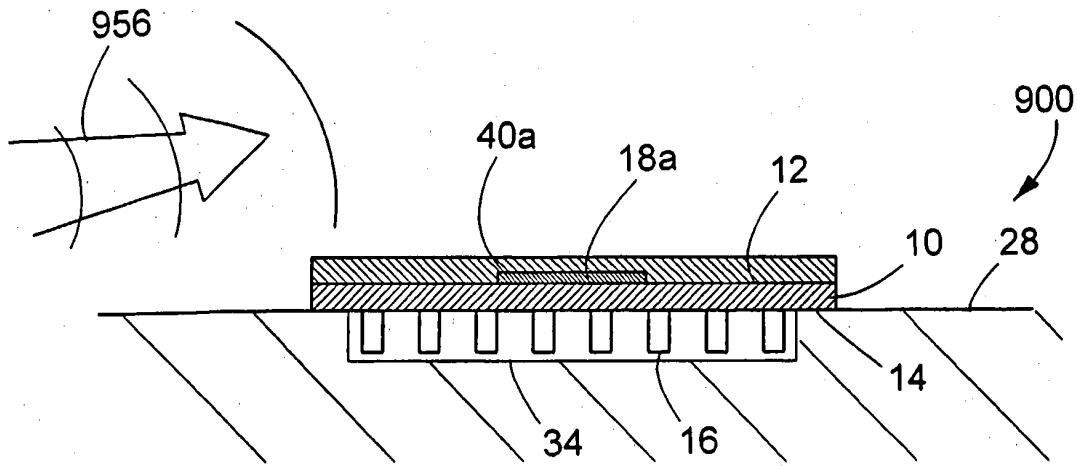

FIG. 12

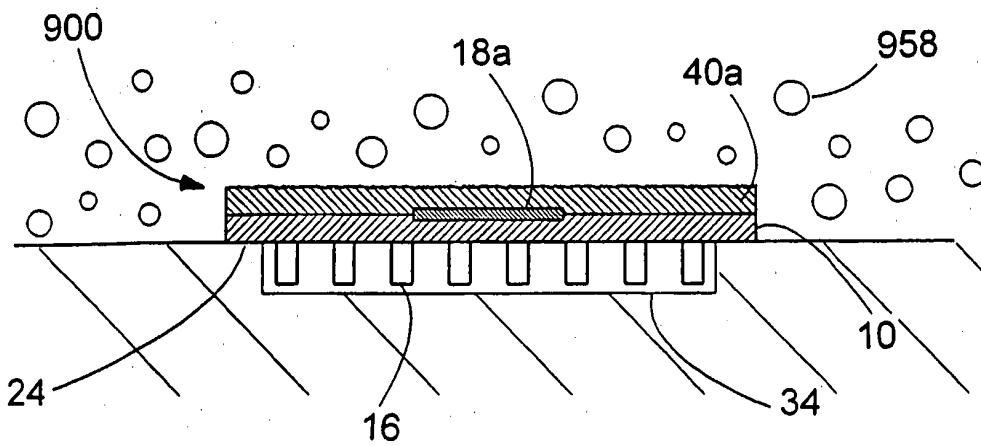

FIG. 13