

A. BECKER.
UNDERFRAME FOR CABS.
APPLICATION FILED JAN. 14, 1908.

983,263.

Patented Feb. 7, 1911.

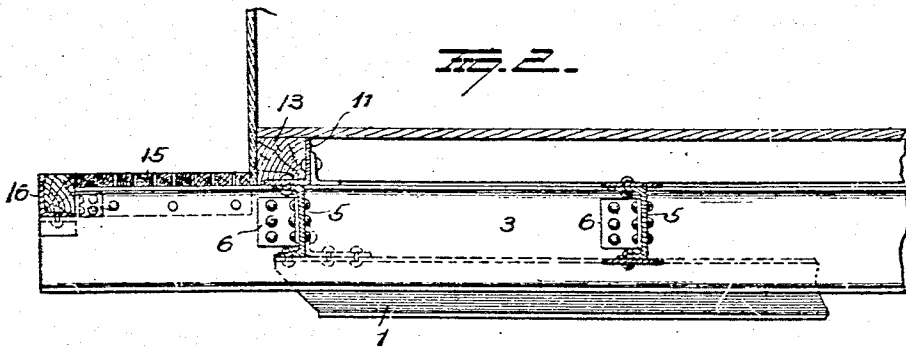
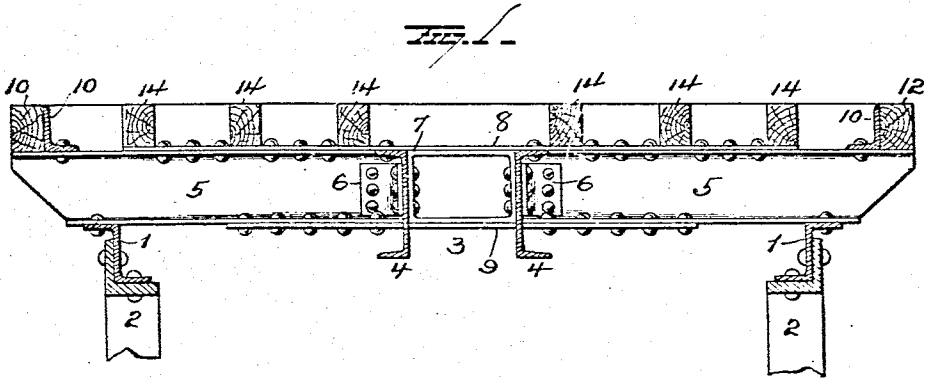

WITNESSES
E. Nottingham
G. J. Downing

INVENTOR
A. Becker
By H. A. Seymour
Attorney

UNITED STATES PATENT OFFICE.

ANTON BECKER, OF COLUMBUS, OHIO, ASSIGNOR TO THE RALSTON STEEL CAR COMPANY, OF COLUMBUS, OHIO.

UNDERFRAME FOR CARS.

983,263.

Specification of Letters Patent.

Patented Feb. 7, 1911.

Application filed January 14, 1908. Serial No. 410,791.

To all whom it may concern:

Be it known that I, ANTON BECKER, of Columbus, in the county of Franklin and State of Ohio, have invented certain new and useful Improvements in Underframes for Cars; and I do hereby declare the following to be a full, clear, and exact description of the invention, such as will enable others skilled in the art to which it appertains to make and use the same.

My invention relates to improvements in underframes for cars, and more particularly for four-wheeled vehicles such as cabooses, where the load is carried upon the journals through the intervention of pedestals and springs, and where pivoted trucks are not employed.

The object of my present invention is to provide an underframe for vehicles of the character above specified, which shall be simple and substantial in construction and which shall comprise few parts supported upon the pedestals through the medium of angle-beams, beyond which latter the transverse members of the structure are made to project.

With this object in view the invention consists in certain novel features of construction and combinations of parts as hereinafter set forth and pointed out in the claims.

In the accompanying drawings, Figure 1 is a transverse sectional view of a car underframe embodying my improvements, and Fig. 2 is a partial longitudinal sectional view.

1, 1 represent angle-beams, which in the present instance are shown as Z-beams, and these are mounted upon and secured to the pedestals 2 in which the journal-boxes for the axles are disposed.

3 represents a center girder which may comprise two channel members 4, 4. To the outer face of each member of the center girder, the inner end of one member of a transverse beam 5 is secured. Each member of the transverse beam may consist of a rolled or pressed channel-iron and secured to a center member girder by means of an angle-iron or gusset plate 6,—or if desired the inner end of each cross-beam member may be provided with a flange secured to the center girder. In either case a filler 7 is disposed between the members at the center girder. The cross-beam members project

beyond the Z-beams 1, 1, rest upon them and are rigidly secured to said Z-beams by means of suitable bolts or rivets. It will be observed that the bottom of the center girder is in a plane above the supports of the Z-beams on the pedestals, and that therefore said center girder is supported or suspended from said Z-beams through the medium of the cross-beams 5. A tension plate or strap 8 extends across the center girder and is securely riveted at respective sides thereof to the flanges of the cross-beam members. A bottom compression plate 9 passes through slots made for its accommodation in the center girder members and said bottom compression plate is secured by rivets to the lower flanges of the cross-beam members.

Angle-irons 10 are secured upon the cross-beams 5 near the outer ends of the latter and extend along the sides of the structure. Similar angle-irons 11 are located at the ends of the frame-work and at the corners of the latter the angle-irons 10 and 11 are secured together by suitable gussets. The base flanges of these angle-irons may project inwardly or outwardly as desired and against the vertical portions of the angle-irons 10, the side-sills 12 (which are supported upon the ends of the cross-beams) abut and may if desired be secured thereto. In a similar manner the end-sills 13 abut against the angle-irons 11 at the ends of the framework.

Furring strips 14 are located upon the cross-beams 5 and extend longitudinally of the structure for supporting the car-flooring. The ends of the center girder members are provided with seats for end sills and the forward portions of the center girder members sustain the car platform.

Having fully described my invention what I claim as new and desire to secure by Letters-Patent, is,—

1. The combination with a center girder and car pedestals, of longitudinal side beams, each having an upper tension-member and a lower compression member, the lower compression members of the side beams resting directly upon the car pedestals, and cross-beams resting directly upon the upper tension members of the side beams and connected with the center girder.

2. The combination with side Z-beams and a center girder, of a cross-bearer fixed to

the center girder and supporting the same, said cross-bearer resting directly upon the side Z-beams and projecting laterally beyond the same.

5 3. The combination with car pedestals and a center girder, of side Z-beams resting directly upon and secured to said pedestals, and cross-bearers resting directly upon the side Z-beams and projecting laterally be-
10 yond the same, said cross-bearers being secured to the center girder and constituting the supporting means for the latter.

15 4. The combination with car pedestals, of side Z-beams located upon said pedestals and having their lower horizontal flanges and their vertical webs secured to said pedestals, cross-bearers secured upon said Z-beams, and a center girder supported by said cross-bearers.

20 5. In a car structure, the combination of Z-beams supported upon the pedestals of the car structure, a center girder and cross-

beams, each comprising two members, one member of each cross-beam secured at its inner end to the center girder and supported 25 at its outer end by a Z-beam.

6. In a car underframe, the combination with side angle-members adapted to be supported upon the pedestals of a car structure, and a center girder, of cross-beam members 30 comprising channels secured at their inner ends to the center girder and projecting laterally beyond the side-angle-members and secured to the latter, and plates or straps secured to the flanges of said channeled cross- 35 beam members and extending past the center girder.

In testimony whereof, I have signed this specification in the presence of two subscribing witnesses.

ANTON BECKER.

Witnesses:

E. S. CULVER,
F. A. LIVINGSTON.