

(No Model.)

W. EVERED.
PUMP.

No. 466,094.

Patented Dec. 29, 1891.

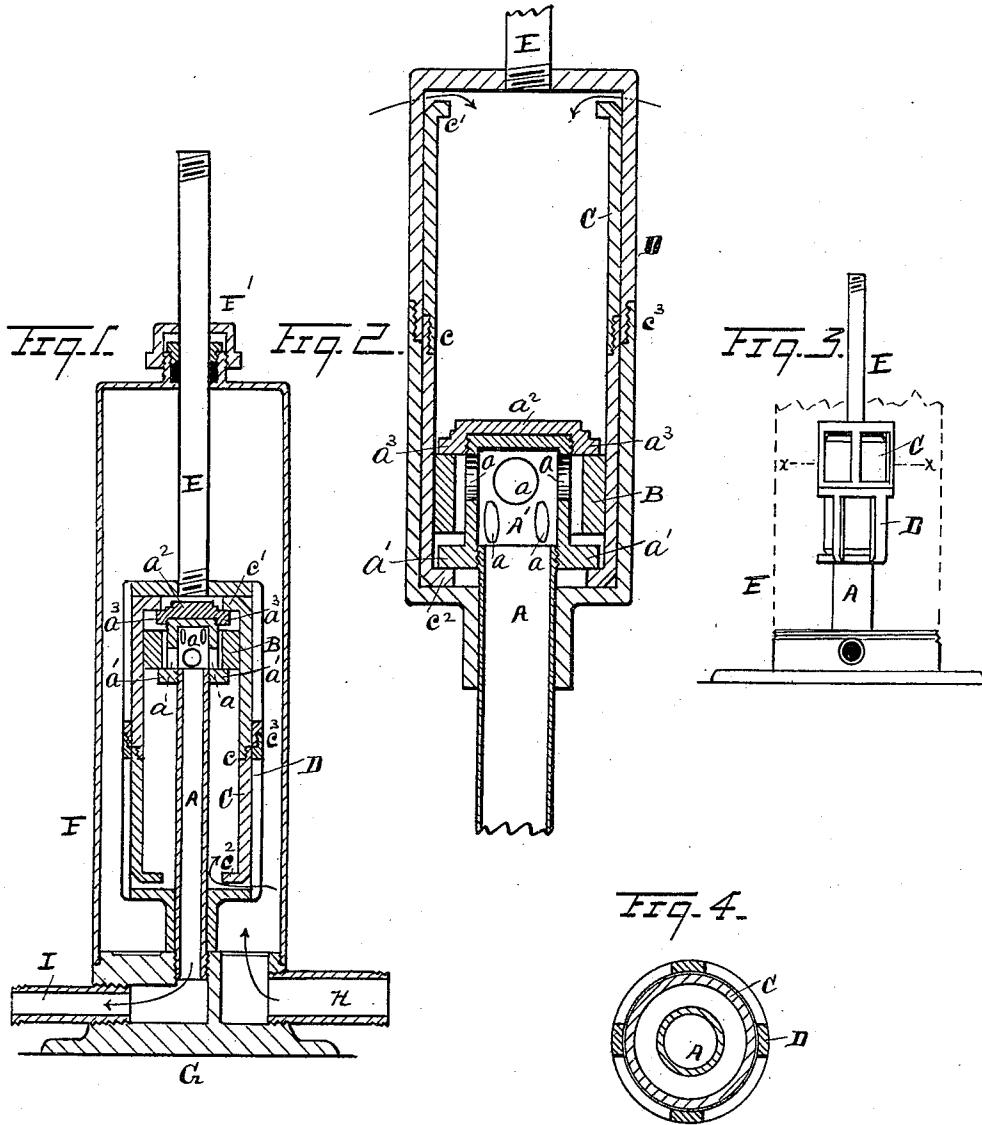

Witnesses
John Schuman.
John F. Miller

Inventor
William Evered
By his Attorney
Newell S. Wright

UNITED STATES PATENT OFFICE.

WILLIAM EVERED, OF DETROIT, ASSIGNOR OF ONE-HALF TO CHARLES H. EVERED, OF WYANDOTTE, MICHIGAN.

PUMP.

SPECIFICATION forming part of Letters Patent No. 466,094, dated December 29, 1891.

Application filed April 20, 1891. Serial No. 389,551. (No model.)

To all whom it may concern:

Be it known that I, WILLIAM EVERED, a citizen of the United States, residing at Detroit, county of Wayne, State of Michigan, have invented a certain new and useful Improvement in Pumps; and I declare the following to be a full, clear, and exact description of the invention, such as will enable others skilled in the art to which it appertains to make and use the same, reference being had to the accompanying drawings, which form a part of this specification.

My invention relates to certain new and useful improvements in pumps; and it consists of the combinations of devices and appliances hereinafter specified and claimed, and illustrated in the accompanying drawings, in which—

Figure 1 is a vertical section embodying my invention, showing the cage and contained cylinder at the limit of the downward stroke of the piston-rod. Fig. 2 is a similar but enlarged view of features of the device, showing the cage and cylinder at the limit of the upward stroke of the piston-rod. Fig. 3 is a side elevation with the outer case removed, showing the cage and piston in the position occupied in Fig. 2; and Fig. 4 is a cross-section on the line $x x$, Fig. 3.

The design of my invention is to provide a pump of simple and economical construction and of superior efficiency in its operation, as well as one adapted for numerous uses.

More particularly my invention is intended to provide a submerged double-acting pump quick in its operation, whereby a continuous stream may be forced thereby under a very considerable pressure.

I carry out my invention as follows:

A in the drawings represents a stand-pipe provided with a head A' , constructed with a desired number of ports a , communicating with the interior of the stand-pipe, some of the ports being located toward the top of the head and others toward the bottom thereof, as shown. The base of the head is constructed with an outwardly-extended flange or annular rim a' . At the top of the head a cap a^2 has a screw-threaded engagement thereon, said cap provided with an outwardly-extended rim a^3 . Between the rim a' of the base

of the head and the rim a^3 at the top thereof is located an annular ring or valve B, having a limited vertical movement between said rims a' a^3 , so as to leave an opening between it and one of said rims, according as it is moved upward or downward. If the valve is lifted, it seats against the rim a^3 and leaves an opening between its lower edge and the rim a' , and vice versa.

When the opening is at the base of the valve, communication is afforded therethrough and through the lower ports in the head A' with the interior of the pipe A. So, also, when the valve seats on the rim a' an opening is formed at the top of the valve between its upper edge and the rim a^3 , communicating through the upper ports in said head with the interior of said pipe. It will thus be seen that the valve B is a double-seated valve, and so double-acting as it moves upward and downward.

C is a cylinder located about the pipe A and head A' and valve B, as shown, preferably made in two parts, having a screw-threaded engagement with each other at their adjacent edges, as shown at c , to facilitate the location of the parts in place and their removal in case of needed repairs. This cylinder is constructed with inwardly-extended annular rims or flanges c' c^2 at its upper and lower ends.

D denotes a cage in which the cylinder is located, engaged with a reciprocating rod E at its upper end and having a movable engagement about the pipe A at its base. This engagement of the base of the cage about the pipe is made tight in any suitable manner to prevent leakage therebetween. For convenience of locating the cylinder C therein the cage is preferably made in two parts, having a screw-threaded connection, as shown at c^2 .

The cylinder C, it should be observed, has a limited vertical movement in the cage, the two being so constructed that the cylinder may seat upon the cage at the top or bottom alternately, the cylinder thus acting as a double-seated valve in the upward and downward movement of the piston.

F denotes a surrounding case, through which the reciprocating rod passes, as through a stuffing-box F' at the top.

G is a base, upon which the stand-pipe and case are supported.

H denotes an inlet-pipe communicating with the interior of the case, preferably through the base, as shown, and I denotes an outlet-pipe communicating with the interior of the stand-pipe, preferably through the base, and with which connection may be made to carry the water forced by the pump to any desired point.

The action of the device will now be readily understood.

In the working of the pump the case F is first emptied of air and filled with water, thus submerging the cylinder C and cage D therein. On the upward stroke of the reciprocating rod it will be seen that the cage is lifted into contact with the cylinder at its base and carries the cylinder therewith, seating the cylinder at the base and leaving an opening at the top of the cylinder between its upper end and the top of the cage, as shown in Fig. 2, allowing the water to enter the cylinder thereat from the chamber formed by the surrounding case F, and thereby filling the upper end of the cylinder above the valve B. On the downward stroke of the reciprocating rod the cylinder seats on the upper end of the cage, and said valve is carried downward away from its seat on the cap, leaving an opening therebetween, through which the water is forced, and through the upper ports in the head A' into the stand pipe A, and thence through the outlet-pipe I. As the cylinder thus descends, the rim c' seats on top of the cap before the cage has reached the limit of its stroke, thereby causing an opening at the base of the cylinder between it and its seat upon the lower end of the cage, through which water also enters into the cylinder below the valve B. The upward movement of the reciprocating rod causes the cylinder to seat at its lower end, as already observed, and the valve B is lifted off its seat on the rim a' , and the water is forced through the lower ports in the head A' into the stand-pipe. In this manner the pump is double-acting, and the suction produced thereby, causing a consequent vacuum, sucks the water into the cylinder at each end alternately and forces it through the stand-pipe.

I have described my invention as occupying a vertical position; but obviously it will work the same in other positions, as may be desired. It will be seen that in reality three

causes are at work to operate the valve B— frictional contact with the cylinder; suction, and the pressure of the current discharged into the stand-pipe. The same causes also assist in the operation of the cylinder. The rim c^2 in the action of the pump serves to steady the cylinder and hold it to its seat when seated at its lower end.

What I claim as my invention is—

1. In a pump, the combination, with the stand-pipe provided with inlet-ports and having valve seats above and below said ports, of a valve made reciprocatory between said seats, an open-ended cylinder having a reciprocatory engagement about the inlet end of said stand-pipe, and a cage engaging said cylinder and provided with valve-seats at its extremities, upon which the cylinder alternately seats, and a reciprocating rod connected with said cage, substantially as described.

2. In a pump, the combination, with the stand-pipe provided with inlet-ports and having valve-seats above and below said ports, of a valve made reciprocatory between said seats, an open-ended cylinder having a reciprocatory engagement about the inlet end of said stand-pipe and a cage engaging said cylinder and provided with valve-seats at its extremities, upon which the cylinder alternately seats, a reciprocating rod connected with said cage, and a case located about said cage, having an inlet thereinto, substantially as described.

3. In a pump, the combination, with the stand-pipe provided with inlet-ports and having valve-seats above and below said ports, of a valve made reciprocatory between said seats, an open-ended cylinder having a reciprocatory engagement about the inlet end of said stand-pipe and a cage engaging said cylinder and provided with valve-seats at its extremities, upon which the cylinder alternately seats, a reciprocating rod connected with said cage, a case located about said cage, and a base supporting said case and stand-pipe, having an inlet into said case and an exit-passage communicating with said stand-pipe, substantially as described.

In testimony whereof I sign this specification in presence of two witnesses.

WILLIAM EVERED.

Witnesses:

N. S. WRIGHT,
JOHN F. MILLER.