



US 20060098380A1

(19) **United States**

(12) **Patent Application Publication**  
**Boucher**

(10) **Pub. No.: US 2006/0098380 A1**

(43) **Pub. Date: May 11, 2006**

(54) **TIMER-CONTROLLED CLAMP FOR INITIATION ELEMENTS**

**Publication Classification**

(76) Inventor: **Craig J. Boucher**, Simsbury, CT (US)

(51) **Int. Cl.**  
**F23Q 3/00** (2006.01)

(52) **U.S. Cl.** ..... **361/247**

Correspondence Address:  
**CANTOR COLBURN, LLP**  
**55 GRIFFIN ROAD SOUTH**  
**BLOOMFIELD, CT 06002**

(57) **ABSTRACT**

This invention relates to protective circuitry (12) for electrical initiation elements (10) and finds utility in preventing inadvertent functioning of electrical bridge-initiation elements, such as semiconductor bridges (SCBs), bridgewires, etc., by transient environmental electrical signals. The protective circuitry (12) of this invention comprises a timer portion (14) and a clamping portion (16) and is designed to divert from the electrical initiation element (10) at least a portion of an electrical signal received at the input nodes (10a, 10b) thereof for a suitable time interval that corresponds to the duration of an expected transient signal, which is typically significantly smaller than the duration of a proper initiation signal.

(21) Appl. No.: **10/521,955**

(22) PCT Filed: **Jul. 21, 2003**

(86) PCT No.: **PCT/US03/22723**

**Related U.S. Application Data**

(60) Provisional application No. 60/398,321, filed on Jul. 24, 2002.

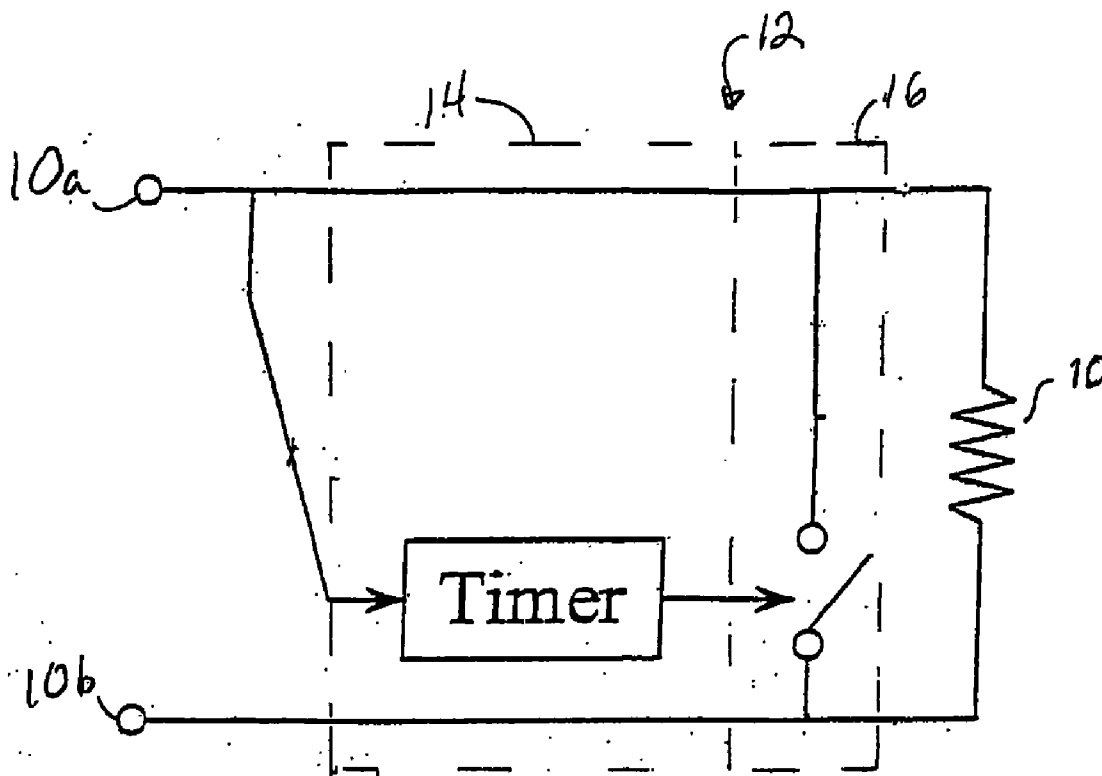

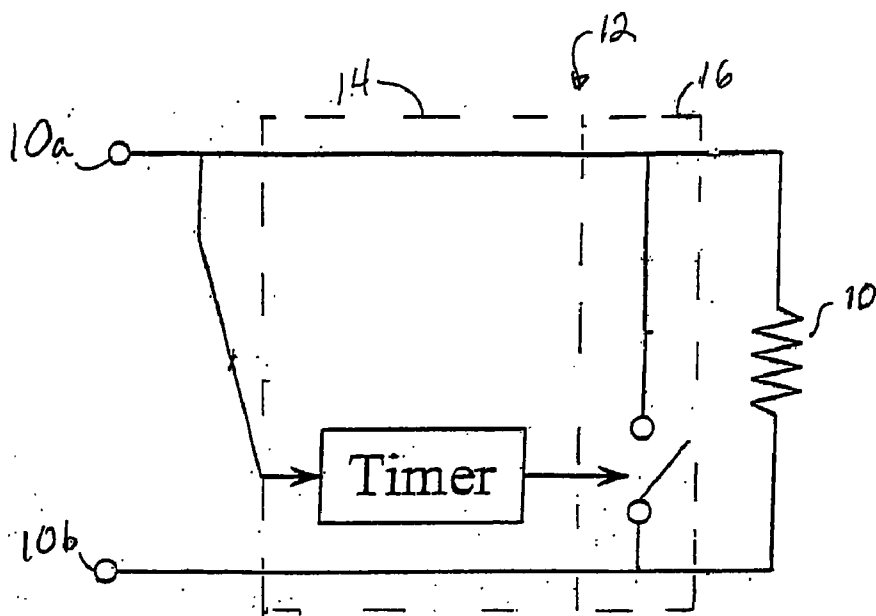

Figure 1.

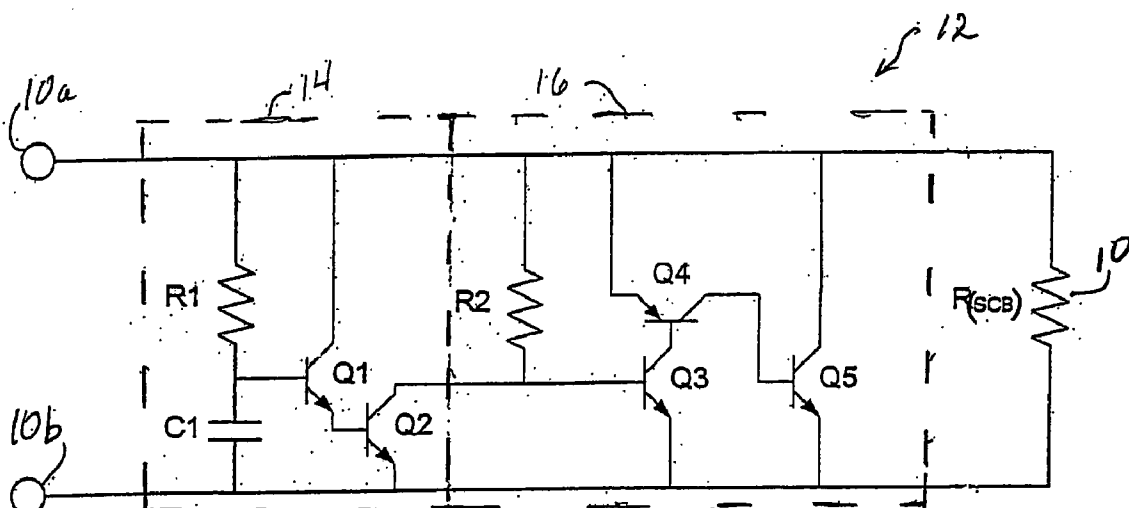

Figure 2.

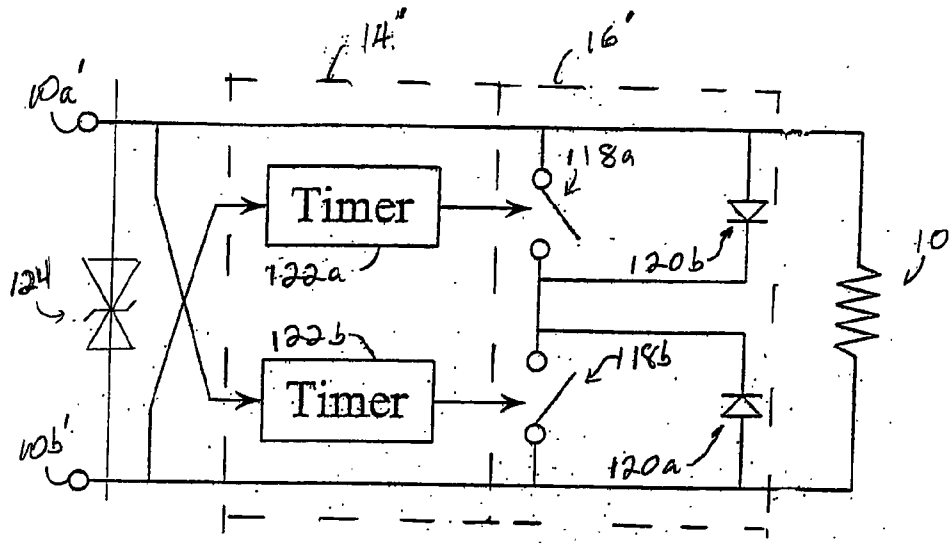

Figure 3

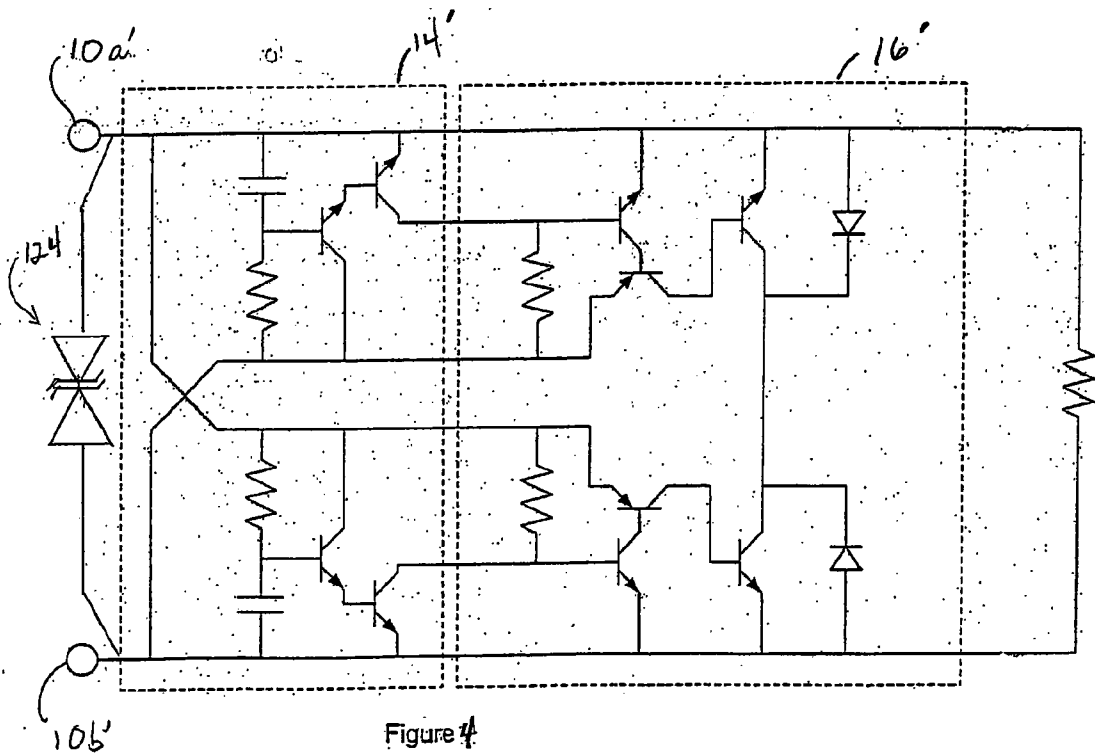

Figure 4

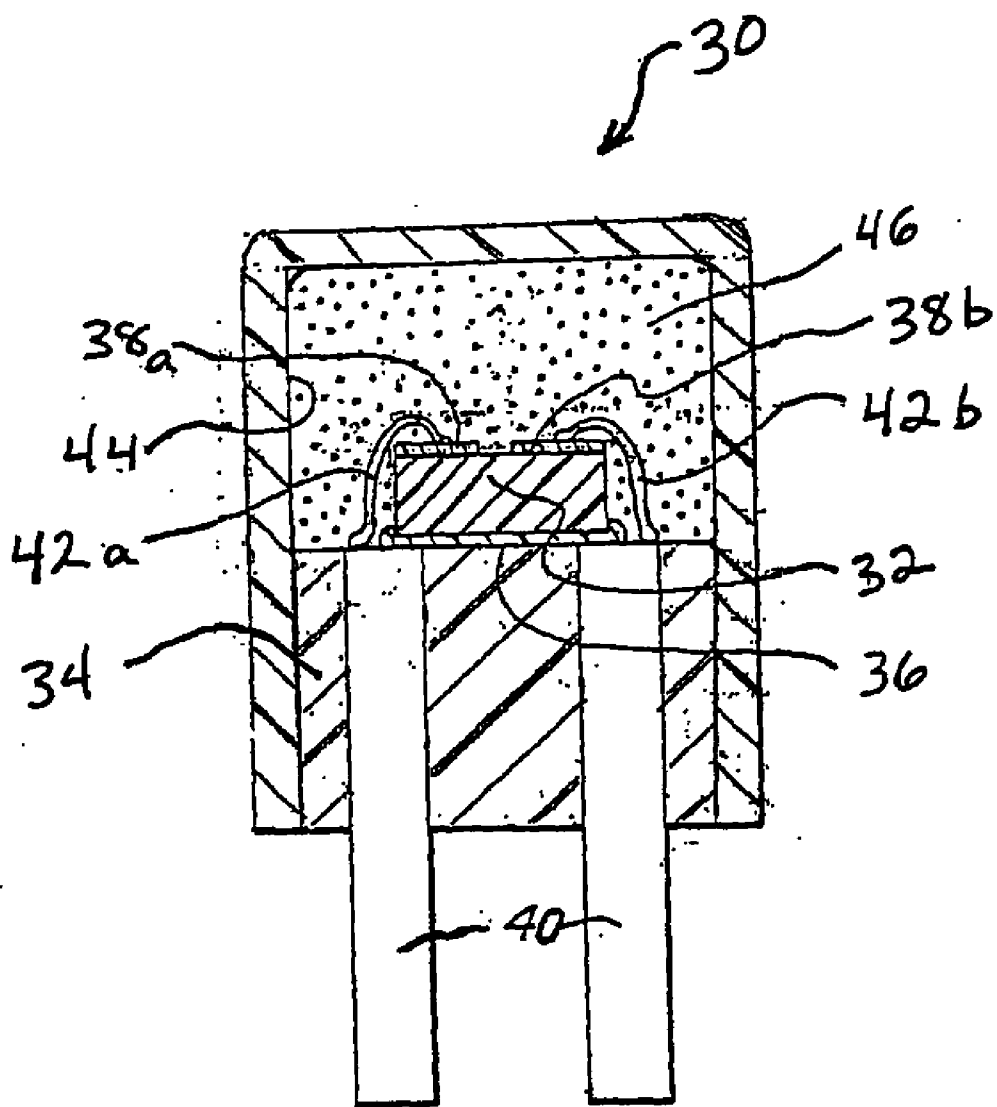

FIG. 4A

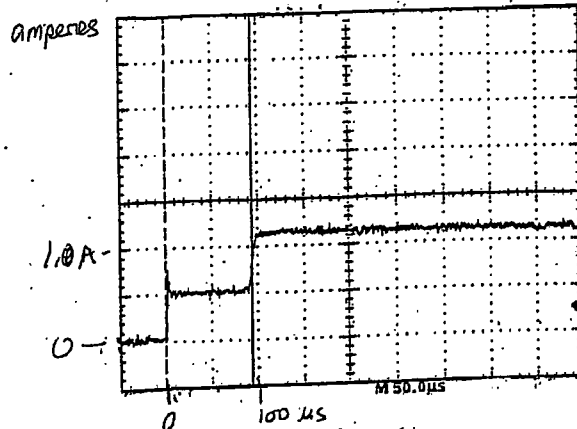

FIG. 5 1.2A Firing Input

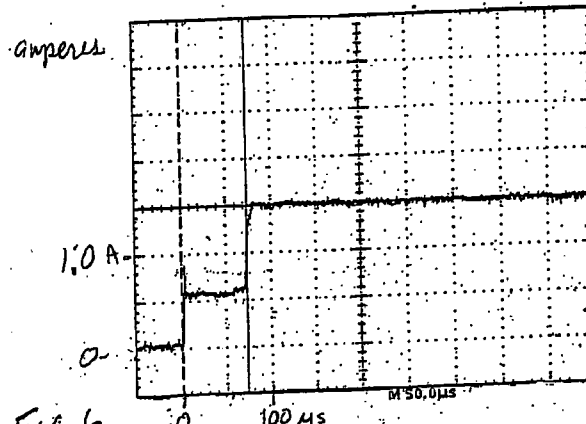

FIG. 6 1.5A Firing Input

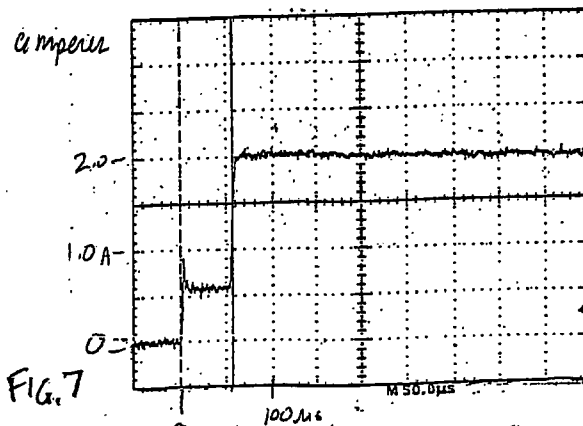

FIG. 7 2.0A Firing Input

**TIMER-CONTROLLED CLAMP FOR INITIATION ELEMENTS**

BACKGROUND OF THE INVENTION

Field of the Invention

[0001] This invention relates to protection circuitry for electrical components and, in particular, to the protection of electrical initiation elements for use with reactive material, e.g., in squibs, detonators, and the like.

SUMMARY OF THE INVENTION

[0002] This invention provides an initiator device comprising an electrical initiation element having signal input nodes thereto with protective circuitry connected across the signal input nodes. The protective circuitry comprises a clamping portion responsive to input signals at the input nodes to divert from the initiation element at least a portion of such input signals, the clamping portion being responsive to a release signal to permit the input signal to pass to the initiation element upon receipt of such release signal, and a timer portion connected to the clamping circuit and to the input nodes, and being responsive to such input signals, for issuing a release signal to the clamping portion after passage of a clamping interval after the receipt of the input signal.

[0003] According to one aspect of the invention, the clamping interval may be about 100 microseconds or less. For example, the clamping interval may be in the range of from about 1 microsecond to about 100 microseconds, or from about 10 microseconds to about 100 microseconds.

[0004] In various embodiments of the invention, the initiator device may comprise a unipolar clamping circuit and a unipolar timer circuit, or it may comprise a bipolar clamping circuit and a bipolar timer circuit.

[0005] Optionally, one or both of the electrical initiation element and the protective circuitry may be formed as integrated circuitry. For example, the initiation element and protective circuitry may be mounted on a header comprising two electrical leads connected to the protective circuitry, and the device may further comprise a shell mounted on the header and a charge of reactive material in the shell for initiation by the initiation element.

BRIEF DESCRIPTION OF THE DRAWINGS

[0006] **FIG. 1** is a schematic representation of unipolar active clamping circuitry with an electrical initiation element in accordance with this invention;

[0007] **FIG. 2** is a circuit diagram of a particular embodiment of the circuitry of **FIG. 1**;

[0008] **FIG. 3** is a schematic representation of bipolar clamping circuitry according to the present invention, with an electrical initiation element;

[0009] **FIG. 4** is a circuit diagram of a particular embodiment of active clamping circuitry as represented in **FIG. 3**;

[0010] **FIG. 4A** is a schematic cross-sectional view of an initiator comprising an electrical initiation element with protective circuitry according to the present invention; and

[0011] **FIGS. 5, 6 and 7** are plots of current flowing through a resistive element in place of an electrical initiation

element as described in the Example, from which the clamping intervals are evident.

DETAILED DESCRIPTION OF THE INVENTION AND PREFERRED EMBODIMENTS THEREOF

[0012] This invention relates to protective circuitry for electrical initiation elements of the kind commonly used to initiate reactive effectors, i.e., explosive or pyrotechnic devices such as initiators (squibs, detonators, etc.), exploding bolts, etc. The protective circuitry serves to prevent inadvertent functioning of the initiation element in response to a transient environmental electrical signal while allowing the initiation element to function in response to a proper initiation signal. The circuitry functions by diverting (“clamping”) from the electrical initiation element at least a portion of an input electrical signal for a time interval (the “clamping interval”) that corresponds to the duration of a typical transient signal. In this way, transient signals do not initiate the initiation element. The clamping interval is significantly smaller than the duration of a proper initiation signal, so that an adequate proportion of a proper initiation signal can pass to the initiation element to make it function. The protective circuitry of this invention therefore has clamping circuitry and timer circuitry to which the clamping circuitry is responsive and which determines the clamping interval.

[0013] The protective circuitry of this invention takes advantage of the fact that many transient pulses capable of causing the inadvertent functioning of an initiation element are much shorter in duration than a bona fide initiation signal. The protective circuitry therefore functions by diverting away from the initiation element, for a short time interval (“the clamping interval”), at least a portion of any input current above a minimum threshold supplied to the initiation element. After the clamping interval, the input current is permitted to flow to the initiation element. The clamping interval is selected to be long enough to block a typical transient signal, but not so long that the reliability of the response of the initiation element to a bona fide initiation signal is significantly affected. The response of the initiation element to the initiation signal is delayed by the clamping interval, so the initiation signal must exceed the function time of the initiation element by at least as much as the clamping interval.

[0014] In a typical embodiment, the protective circuitry for a semiconductor bridge (SCB) initiation element designed to have a function time of less than 500 μs in response to a 2 millisecond (ms), 1 ampere (A) initiation signal may limit the bridge current to not more than about 0.5 A during a clamping interval of up to about 100 microseconds (tes). Thus, the clamping interval may last for up to about 20% of the expected function time of the initiation element given the proper initiation signal and, in this example, up to about 5% of the duration of the initiation signal. Preferably, the protective circuitry is designed to clamp input signals that fall within its no-fire limitation for the device, which may require that the SCB not fire in response to a rectangular 2.5 A input signal lasting 50 μs at 25° C., or a 5.3 A, 4 μs rectangular pulse. Typically, the clamping interval will be at least about 1 μs, preferably at least 10 μs.

[0015] Protective circuitry according to this invention comprises a clamping portion and a timer portion. A general

representation of a unipolar embodiment of such protective circuitry is shown in **FIG. 1**, connected to an electric initiation element or "bridge" **10**, which may be, e.g., an SCB, a titanium bridge, an exploding bridgewire, etc. The protective circuitry **12** comprises a timer portion **14** comprising a timer circuit and a clamping portion **16** comprising a clamping circuit, both of which are powered by an input signal received at nodes **10a** and **10b**. Bridge **10** receives initiation signals and, possibly, various undesired signals such as circuit transients, electrostatic discharge, etc., via nodes **10a** and **10b**. The clamping portion **16** is connected across bridge **10** in parallel thereto relative to nodes **10a** and **10b**. In effect, clamping portion **16** comprises a switch which, when closed, creates a circuit in parallel with bridge **10** that diverts away from bridge **10** a significant portion of any current generated by a potential across nodes **10a** and **10b**. The clamping portion **16** is responsive to the initial application of a potential across nodes **10a** and **10b** which, in the illustrated circuit, defines a potential across bridge **10**. However, the operation of clamping portion **16** is controlled by timer portion **14**, which disables the clamping portion **16** after a predetermined time interval (the clamping interval) by generating a release signal that causes the clamping circuit to release (i.e., stop clamping) the input signal. If a potential remains across nodes **10a** and **10b** after the clamping interval, any current generated thereby will then flow through bridge **10** and may cause bridge **10** to function.

[0016] A circuit diagram of the particular embodiment of the protective circuitry **12** of **FIG. 1** is provided in **FIG. 2**. As shown in this Figure, the timer circuit of timer portion **14** comprises an RC circuit (resistance **R1** and capacitor **C1**) together with transistors **Q1** and **Q2**. The clamping circuit of clamping portion **16** comprises a shunt switch comprising a resistor **R2** and transistors **Q3**, **Q4** and **Q5**. The operation of such protective circuitry **12** is described in the Example below.

[0017] The protective circuitry shown in **FIG. 2** is unipolar in nature, i.e., it will function only in response to a potential across nodes **10a** and **10b** of a particular polarity. However, unwanted stray currents and discharges across nodes **10a** and **10b** might also have the opposite polarity to which the circuit of **FIG. 2** cannot respond, leaving the bridge **10** vulnerable to inadvertent firing. For this reason, it is preferred to provide bipolar active clamping circuitry to protect against the inadvertent function of an electrical initiation element.

[0018] A schematic representation of bipolar protective circuitry according to **FIG. 1** connected across a bridge and nodes **10a'**, **10b'** is shown in **FIG. 3**. As shown in this Figure, timer portion **14'** comprises two timer circuits, timer circuit **122a** and timer circuit **122b**, each designed to operate in response to an input signal of opposite polarity from the other. Clamping portion **16'** comprises two clamping circuits, each comprising a shunt switch that works in conjunction with a diode and which is designed to clamp signals of an opposite polarity from the other. Timer circuit **122a** controls a clamping circuit in clamping portion **16'** comprising a shunt switch **118a** that works in conjunction with diode **120a**. Timer circuit **122a**, shunt switch **118a** and diode **120a** cooperate to provide an active clamping function across bridge **10** for a predetermined clamping interval in response to input signals of a particular polarity. Conversely, timer circuit **122b** controls a clamping circuit comprising a shunt

switch **118b** and diode **120b** to provide the active clamping function in response to signals of an opposite polarity from those to which timer circuit **122a**, etc., respond.

[0019] A circuit diagram of a particular clamping circuit according to the schematic of **FIG. 3** is provided in **FIG. 4**. The circuitry of **FIGS. 3 and 4** include a zener diode portion **124** that protects the bridge, the timer portion and the clamping portion from high power transients such as electrostatic discharges whose magnitudes and/or speed exceed the clamping ability and/or response time of the clamping circuit. The zener diode portion **124** comprises two zener diodes in series but in reverse bias orientation relative to each other across nodes **10a'** and **10b'**.

[0020] Optionally, a zener diode portion may also be employed in the unipolar embodiment of **FIGS. 1 and 2** across nodes **10a** and **10b**, optionally with a suitably biased single diode.

[0021] The circuits represented in **FIGS. 2 and 4** can easily be reduced to practice substantially as shown using discrete circuit elements. However, the preferred embodiment of the clamping circuits and of the electrical initiation element with which they are used is in the form of a solid state integrated circuit die having a solid state initiation element (e.g., a semiconductor bridge (SCB), tungsten bridge, or the like) formed on a suitable substrate. For example, as is well-known in the art, an SCB die comprises a non-conductive substrate on which the SCB and optional associated circuit elements are formed. Such a die is formed with contact pads that provide input nodes to which lead wires can be connected to provide the electrical initiation signal. The protective circuitry of this invention can be formed as integrated circuitry on the die with the initiation element, or on a separate die, or from discrete circuit elements. In producing the integrated circuit embodiments, certain routine alterations to the illustrated circuit diagrams would be made as a matter of routine to accommodate the different characteristics and capabilities of circuit elements (resistors, capacitors, etc.) formed using integrated circuit technology relative to the characteristics of discrete circuit elements.

[0022] There is shown in **FIG. 4A** an initiator comprising an electrical initiation element and associated protective circuitry in accordance with this invention. Initiator **30** comprises an SCB die **32** comprising a non-conductive substrate (e.g., sapphire) on which is formed a semiconductor bridge initiation element and protective circuitry in accordance with this invention, using integrated circuit manufacturing technology. Die **32** is secured to a header **34** by a thin layer of epoxy **36**. Header **34** and epoxy **36** are formed from non-conductive material. Input nodes for the protective circuitry and the semiconductor bridge are provided by metallized lands **38a** and **38b** on the die. Electrical leads **40** are mounted in header **34** and are connected to metallized lands **38a** and **38b** by lead wires **42a** and **42b**. A shell **44** containing a reactive material **46** is secured to header **34** such that reactive material **46** is in contact with the initiation element on die **32**. The reactive material **46** may comprise an explosive charge, whereby upon the functioning of the semiconductor bridge, reactive material **46** will generate an explosive output from shell **44**. Alternatively, reactive material **46** may comprise a pyrotechnic material that generates a pyrotechnical output.

## EXAMPLE

[0023] A prototype clamping circuit according to the circuit diagram of FIG. 2 was assembled and tested on a breadboard using commercially available parts. Specifications for the circuit elements used in the circuit are as follows.

C1	100 pF Ceramic Capacitor, 10%, 100 V
Q1-3	2N2222A NPN Small Signal Transistor
Q4	2N2907A PNP Small Signal Transistor
Q5	MMJT9410T1 NPN Medium Power Transistor
R1	249 k $\Omega$ , 1%, 0.1 W, Metal Film
R2	10 k $\Omega$ , 1%, 0.1 W, Metal Film
R <sub>(SCB)</sub>	Two 1 $\Omega$ , 1 W, Wirewound in series (simulates a standard SCB)

[0024] Transistors Q1-Q5 were bipolar junction transistors with a beta of about 75, preferably at least about 50. Transistor Q5 must be capable of handling large currents (e.g., about 1 ampere (A)) with a low  $V_{CE}$ . Upon the application of a simulated input current transient, a voltage developed across R<sub>(SCB)</sub> (which is a nominal 2  $\Omega$  resistance) (For testing purposes, a resistor is used in place of an SCB or other electric initiation element.). Until capacitor C1 charges sufficiently to activate transistor Q1, both transistors Q1 and Q2 are held in the “off” state. This allows current to flow through resistor R2, providing base drive to transistor Q3. The transistor Q3 collector current provides base drive to transistor Q4, which in turn provides base drive to transistor Q5, which shunts at least a portion of the input current away from resistor R<sub>(SCB)</sub>.

[0025] The timer circuit operates by delaying the turn-on of transistor couple Q1/Q2 until capacitor C1 has charged sufficiently to activate transistor Q1. At that point, transistor Q1 turns on and provides base drive to transistor Q2. Transistor Q2, when on, effectively generates a release signal that clamps the base-emitter voltage of transistor Q3, which turns off transistors Q4 and Q5, allowing substantially all of the remaining input current to flow through resistor R<sub>(SCB)</sub>. Due to the large current gain, the collector-emitter saturation voltage  $V_{CE(SAT)}$  of transistor Q3 should always be less than  $V_{CE(SAT)}$  of transistor Q4, and, similarly, the base-emitter voltage  $V_{BE}$  of transistor Q4 should always be less than  $V_{BE}$  of transistor Q5.

[0026] The circuit contains hysteresis when the clamp turns off. Once the capacitor C1 voltage is large enough to turn on transistor couple Q1/Q2, the clamp begins to turn off. Assuming a constant input current, the current through resistor R<sub>(SCB)</sub> begins to rise as the clamping circuit turns off, resulting in a larger voltage across resistor R<sub>(SCB)</sub>. This positive feedback, together with the high circuit gain, produces a fast turnoff of the clamping circuit. This should be kept in mind in the event resistor R1 is replaced by a current source to reduce the delay variation caused by variation in the input current. A current source embodiment of that kind is not expected to have such a dramatic positive feedback.

[0027] Inherently, the particular circuit elements chosen for the timer circuit and the clamping circuit will make those circuits unresponsive to input signals of less than a threshold magnitude, thus providing an inherent threshold sensing function to the protective circuitry. For example, the clamp-

ing circuit will not function unless the input signal generates a current in R2 sufficient to activate transistor Q3. Similarly, the timer circuit transistor couple Q1/Q2 will not turn on until the input voltage exceeds their combined  $V_{BE}$  thresholds. In this example, this means that there will be a range of input currents between 0.5 A and 0.6 A where the clamp will most likely turn on, but may not turn off. The protective circuitry is easily designed by one of ordinary skill in the art so that the thresholds are below the magnitude of expected transient signals capable of causing the inadvertent functioning of the initiation element.

[0028] Test data for the breadboard circuit are shown in Table 1 for 50 microsecond current pulse. The input current is the current into the input nodes of the circuit and the bridge current is the current measured through resistor R<sub>(SCB)</sub>.

TABLE 1

Input Current (A)	Current Through R <sub>(SCB)</sub>
0.50	0.42
0.75	0.46
1.00	0.52
1.25	0.54
1.50	0.56
1.75	0.58
2.00	0.60
2.25	0.62
2.50	0.64

[0029] The data of Table I show that at the smallest test current of 0.5 amperes (A), the clamp has already begun to turn on and divert about 80 mA from the bridge. At an input current of 1.0 A the clamp is shunting about one-half of the input current. At the maximum tested transient level of 2.5 A, the clamp shunts about 1.86 A with the remaining 0.64 A flowing through the bridge.

[0030] Further testing was done at a normal firing input of 1.2 A and up to 2.0 A. The resulting waveforms of current through R<sub>(SCB)</sub> are shown in FIGS. 5, 6 and 7. In these Figures, the horizontal axis is graduated in 50  $\mu$ s intervals and the vertical scaling is 0.5 A/division. FIG. 5 shows that, in response to an input signal of 1.2 A, the current received at R<sub>(SCB)</sub> was merely 0.5 A for a clamping interval of about 100  $\mu$ s. Thereafter, the timer released the clamp and the voltage climbed to 1.2 A, i.e., the full input current was received through R<sub>(SCB)</sub>. FIG. 6 shows that, in response to an input signal of 1.5 A, the current received by R<sub>(SCB)</sub> was reduced by the clamping circuit so that a current of merely approximately 0.5 A was developed for a clamping interval of about 75  $\mu$ s. After the clamping interval, the current at R<sub>(SCB)</sub> attained the full 1.5 A. FIG. 7 shows that, in response to an input signal of 2 A, the attenuated current at R<sub>(SCB)</sub> during the clamping interval was merely about 0.5 A and that the clamping interval lasted about 50  $\mu$ s. Thereafter, the timer released the clamping circuit and the full input current was supplied to R<sub>(SCB)</sub>, producing a current of 2 A. The clamping interval becomes predictably shorter as the input current becomes greater, because the greater input current charges capacitor C1 more quickly. However, one skilled in the art, once given the foregoing disclosure, could design active clamping circuitry in accordance with this invention suitable for diverting current from the bridge for any designated clamping interval.



[0031] Although the invention has been illustrated and described with respect to two particular embodiments thereof, it will be understood by one of ordinary skill in the art upon a reading of the foregoing disclosure that numerous alterations and variations of those embodiments fall within the scope of the invention and the following claims.

What is claimed is:

1. An initiator device comprising:

an electrical initiation element having signal input nodes thereto;

protective circuitry connected across the signal input nodes, the protective circuitry comprising a clamping portion responsive to input signals at the input nodes to divert from the initiation element at least a portion of such input signals, the clamping portion being responsive to a release signal to permit the input signal to pass to the initiation element upon receipt of such release signal; and

a timer portion connected to the clamping portion and to the input nodes, and being responsive to such input signals, for issuing a release signal to the clamping portion after passage of a clamping interval after the receipt of the input signal.

2. The initiator device of claim 1 wherein the clamping interval is about 100 microseconds or less.

3. The initiator device of claim 2 wherein the clamping interval is in the range of from about 5 microseconds to 100 microseconds.

4. The initiator device of claim 2 wherein the clamping interval is in the range of from about 20 microseconds to 100 microseconds.

5. The initiator device of claim 1 comprising a unipolar clamping circuit and a unipolar timer circuit.

6. The initiator device of claim 1 comprising a bipolar clamping circuit and a bipolar timer circuit.

7. The initiator device of claim 1 wherein at least one of the electrical initiation element and the protective circuitry are formed as integrated circuitry.

8. The initiator device of claim 7 wherein the initiation element and protective circuitry are mounted on a header comprising two electrical leads connected to the protective circuitry, and further comprising a shell mounted on the header and a charge of reactive material in the shell for initiation by the initiation element.

\* \* \* \* \*