



(11) **EP 1 898 049 A1**

(12) **EUROPEAN PATENT APPLICATION**

(43) Date of publication:
12.03.2008 Bulletin 2008/11

(51) Int Cl.:
F01D 5/12 (2006.01) F01D 5/30 (2006.01)

(21) Application number: **06019003.0**

(22) Date of filing: **11.09.2006**

(84) Designated Contracting States:
AT BE BG CH CY CZ DE DK EE ES FI FR GB GR HU IE IS IT LI LT LU LV MC NL PL PT RO SE SI SK TR
Designated Extension States:
AL BA HR MK YU

(71) Applicant: **SIEMENS AKTIENGESELLSCHAFT 80333 München (DE)**

(72) Inventor: **Brathwaite, Adrian LN6 9UG South Heykeham Lincoln (GB)**

(54) **Turbine blade**

(57) A turbine blade is provided which comprises a platform section (1) having a first side (11), a second side (13) opposite the first side, and, extending from the first side (11) to the second side (13), a leading side (14), a trailing side (16) and peripheral sides (15) extending along a curved path from the leading side (14) to the trailing side (16). It further comprises an airfoil section (3) extending from the first side (11) of the platform section (1) and a root section (5) extending from the second side (13) of the platform section (1). The root section (5) extends along a path from the leading side (14) to the trailing side (16) of the platform section (1) that is straight or has a curvature which is different to the curvature of said curved path.

FIG 1

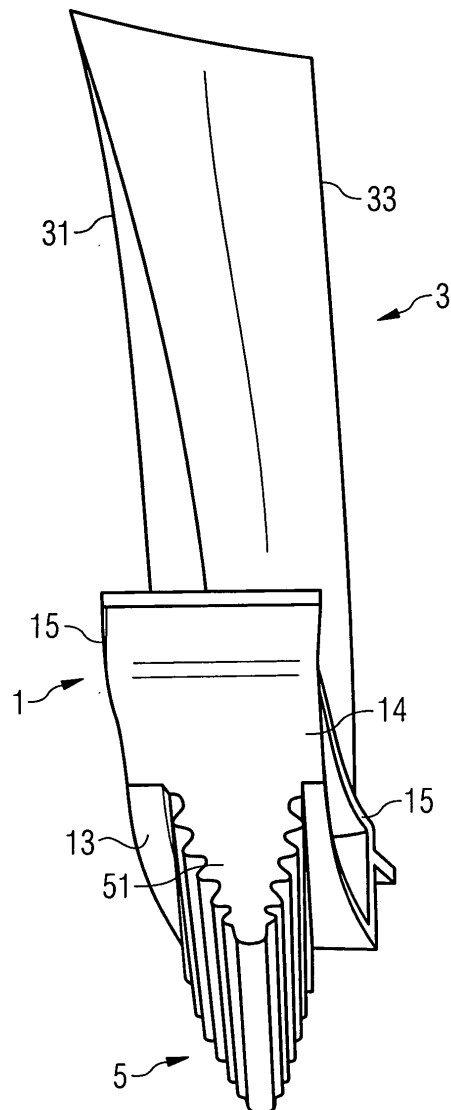

EP 1 898 049 A1

Description

[0001] The present invention relates to a turbine blade comprising a platform section, an airfoil section and a root section.

[0002] From US 5,242,270 and JP 07310502 turbine blades are known in which the platform section has a first side, a second side opposite the first side, and, extending from the first side to the second side, a leading side, a trailing side and peripheral sides extending from the leading side to the trailing side. An airfoil section extends from the platform section's first side, and a root section extends from the platform section's second side. The root section and the peripheral sides of the platform section follow a curved path.

[0003] With respect to the mentioned prior art, it is an objective of the present invention to provide an advantageous turbine blade.

[0004] This objective is solved by a turbine blade according to claim 1. The depending claims define further developments of the inventive turbine blade.

[0005] The inventive turbine blade comprises a platform section, an airfoil section and a root section. The platform section has a first side, a second side opposite to the first side, and, extending from the first side to the second side, a leading side, a trailing side and peripheral sides. The peripheral sides extend along a curved path from the leading side to the trailing side. Further, an airfoil section extends from the first side of the platform section and a root section extends from the second side of the platform section. The root section of the turbine blade extends along a path from the leading side to the trailing side that is straight or has a curvature which is different to the curvature of said curved path.

[0006] By combining the curved peripheral sides of the platform section with a root section extending straight, or with a different curvature, an interlocking of neighbouring turbine blades fixed to a rotor can be achieved.

[0007] Usually turbine blades are fixed by introducing their root sections into notches in a rotor or in a rotor disc of a turbine engine. Although the shape of the notches and the shape of the roots are adapted to each other, roots do not usually fit tightly into the notches. In other words, tolerances between the outer wall of the roots and the inner wall of the notches are present. Such tolerances reduce the risk of damage due to different thermal expansion during operation of the gas turbine engine. In addition, it simplifies introducing the roots into the notches. The shape of the roots and the notches is such that the roots will be held tight in the notches due to centrifugal forces when the gas turbine is in operation, i.e. when the rotor to which the turbine blades are fixed rotates with operation speed. However, if the rotational speed is less, e.g. when the turbine engine is started or barred, the centrifugal force is not strong enough to hold the roots tight in the notches. With turbine blades according to the state of the art this may lead to small movements between the roots and the notches which can cause wear. The

movement of a root in the notch can be in a longitudinal direction of the notch or in a direction perpendicular thereto.

[0008] With the inventive turbine blade the interlocking of neighbouring turbine blades can be achieved due to the fact that the root extends straight while the peripheral sides extend along a curved path. Hence, a longitudinal movement of the blade in a notch will be restricted by the difference in the curvatures of the peripheral sides of the platform section and the root section.

[0009] In contrast thereto, in the turbine blades according to the cited prior art, the peripheral sides of the platform section and the root section show the same curvature. Hence, movement of the turbine blade along the longitudinal direction of the notches is not restricted.

[0010] Moreover, in the inventive turbine blade, the difference in the curvature of the platform's peripheral sides and the root section provides a better strength of the blade and increases the stress/strain distribution during gas turbine operation.

[0011] The root portion may, in particular, extend along a path that is perpendicular to the leading side of the platform section. In addition, the leading side and the trailing side may be parallel to each other.

[0012] In order to enable the turbine blade to be held tight by centrifugal force, the root portion's cross section may have, e.g., a fir tree shape, a bulb shape or a hammer shape.

[0013] The inventive turbine blade may be, in particular, a gas turbine blade or a steam turbine blade.

[0014] Further features, properties and advantages of the present invention will become clear from the following description of an embodiment of the invention in conjunction with the accompanying drawings.

[0015] Figure 1 shows the inventive turbine blade from the leading edge.

[0016] Figure 2 shows the inventive turbine blade from the airfoil section.

[0017] Figure 3 shows the inventive turbine blade in a perspective view onto the root section and the peripheral side of the platform section.

[0018] Figure 4 shows an alternative embodiment of the inventive turbine blade in a perspective view onto the root section and the peripheral side of the platform section.

[0019] An embodiment of an inventive turbine blade will now be described with respect to Figures 1 to 3. The figures show the inventive turbine blade from different sides.

[0020] The turbine blade comprises a platform section 1, an airfoil section 3 and a root section 5 and is made from a nickel (Ni) based alloy or a cobalt (Co) based alloy. The surface of the airfoil section 3 and parts of the surface of the platform section 1 may be provided with a coating, such as a so-called MCrAlY where M stands for an element of the group consisting of iron (Fe), cobalt (Co) and nickel (Ni), Y stands for yttrium and/or silicon and/or at least one element of the rare earths or hafnium (Hf). Such

materials are known, e.g., from EP 0 486 489 B1, EP 0 786 917 B1, EP 0 412 397 B1 or EP 1 306 454 A1. The disclosure of chemical compositions for the MCrAlY provided in these documents is incorporated into the present specification. On the MCrAlY coating a further coating, a so-called thermal barrier coating (TBC), may be present. Such a thermal barrier coating may, e.g., comprise ZrO_2 or $Y_2O_3-ZrO_2$, i.e. Zirconium dioxide coating which is not stabilised, partly stabilised or fully stabilised by yttrium oxide and/or calcium oxide and/or magnesium oxide.

[0021] The turbine blade may be solid or hollow. If the turbine blade is to be cooled during operation of the gas turbine engine, it is hollow and comprises cooling film openings where applicable in order to allow for the production of a cooling air film over the surface of the turbine blade.

[0022] The platform section 1 of the turbine blade comprises a first side, a second side opposite the first side, a leading side 14, a trailing side 16 and two peripheral sides 15 which extend from the leading side 14 to the trailing side 16. The airfoil section 3, which comprises a leading edge 31 and a trailing edge 33, extends from the first side 11 of the platform section 1, and the root section 5 extends from the second side 13 of the platform section 1.

[0023] The platform section 1 shows a curvature in its peripheral sides 15 whereas the root section extends along a straight line from the leading side 14 of the platform to the trailing side 16 of the platform.

[0024] Although the root section 5 is shown to extend straight, it may as well be curved, as it is shown in Figure 4 for a bulb shaped root section 105. If the root section 105 extends along a curved path from the leading side 14 to the trailing side 16, the curvature of the root section 105 is, however, different to the curvature of the peripheral sides 15. The curvature may, e.g., have a different value for the radius or, like it is shown in Figure 4, may have the opposite orientation with respect to the curvature of the peripheral sides 15 of the platform section 1, i.e. one is curved to the right while the other is curved to the left.

[0025] The cross-sectional shape of the root section is, in the present embodiments, a fir tree shape 51 (Figures 1 and 3) and a bulb shape 151 (Figure 4), respectively. However, the root section may also have a different cross-sectional shape which is suitable for allowing the turbine blade to be held tight in a notch of a rotor during operation of a gas turbine engine.

[0026] Note that although the leading side 14 of the platform section 1 is parallel to the trailing side 16 in the shown embodiments this does not necessarily need to be so. Instead, the sides 14, 16 could include an angle relative to each other. Moreover, the centre line of a straight root section 5 as described with respect to Figures 1 to 3 does not need to be perpendicular to the leading and/or trailing side of the platform.

[0027] With the inventive design of a turbine blade the

interlocking of adjacent blades during assembly of a turbine blade with a rotor or a rotor disc is possible. Moreover, the stress/strain distribution through the plates can be improved which in turn leads to an increased strength of the blades. This offers the possibility of increasing the chord of the airfoil section without negative impact to the overall strength of the turbine blade.

10 Claims

1. A turbine blade comprising:

- a platform section (1) having a first side (11), a second side (13) opposite the first side (11) and, extending from the first side (11) to the second side (13), a leading side (14), a trailing side (16) and peripheral sides (15) extending along a curved path from the leading side (14) to the trailing side (16) ;
- an airfoil section (3) extending from the first side (11) of the platform section (1); and
- a root section (5) extending from the second side (13) of the platform section (1);

characterised in that the root section (5) extends along a path from the leading side (14) to the trailing side (16) of the platform section (1) that is straight or has a curvature which is different to the curvature of said curved path.

2. The turbine blade as claimed in claim 1 **characterised in that** the root section (1) extends along a path that is perpendicular to the leading side (14).

3. The turbine blade as claimed in claim 1 or claim 2 **characterised in that** the leading side (14) and the trailing side (16) are parallel to each other.

4. The turbine blade as claimed in any of the claims 1 to 3 **characterised in that** the root section (5) has a fir tree shape, a bulb shape or a hammer shape.

5. The turbine blade as claimed in any of the claims 1 to 4 **characterised in that** it is a gas turbine blade or a steam turbine blade.

FIG 1

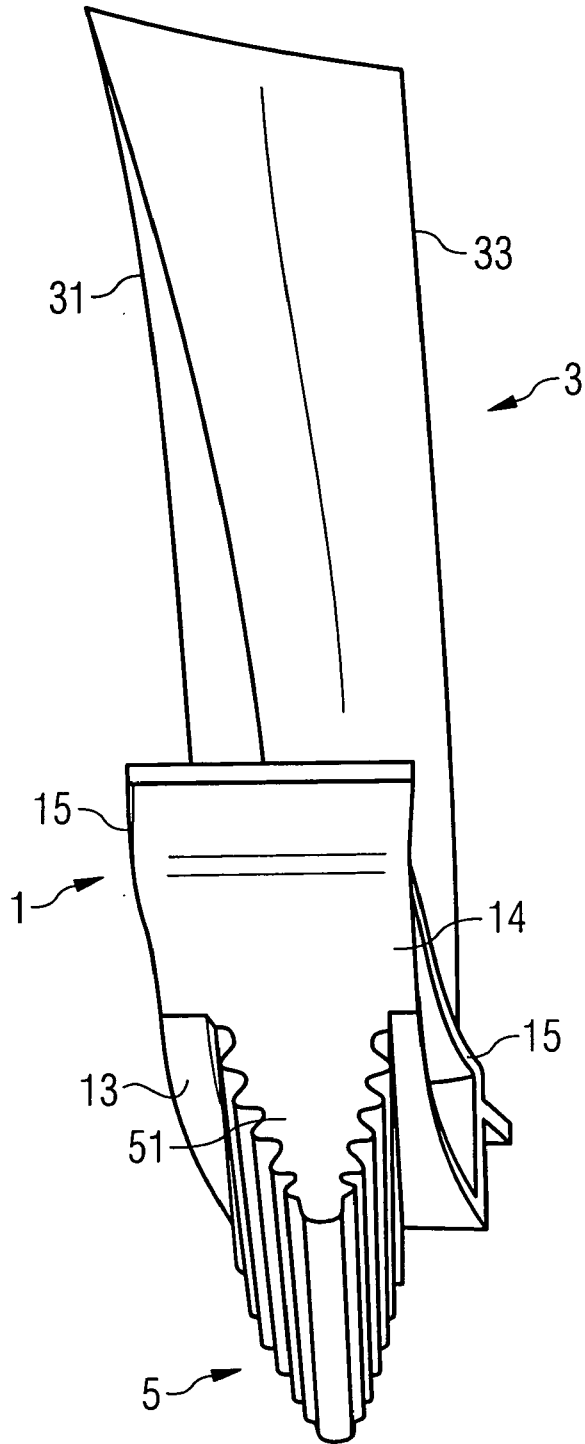

FIG 2

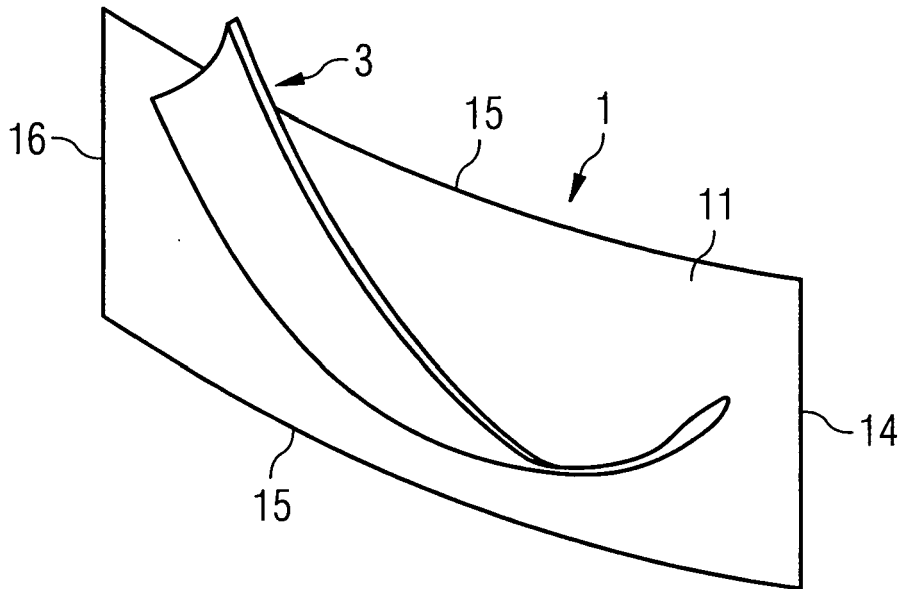

FIG 3

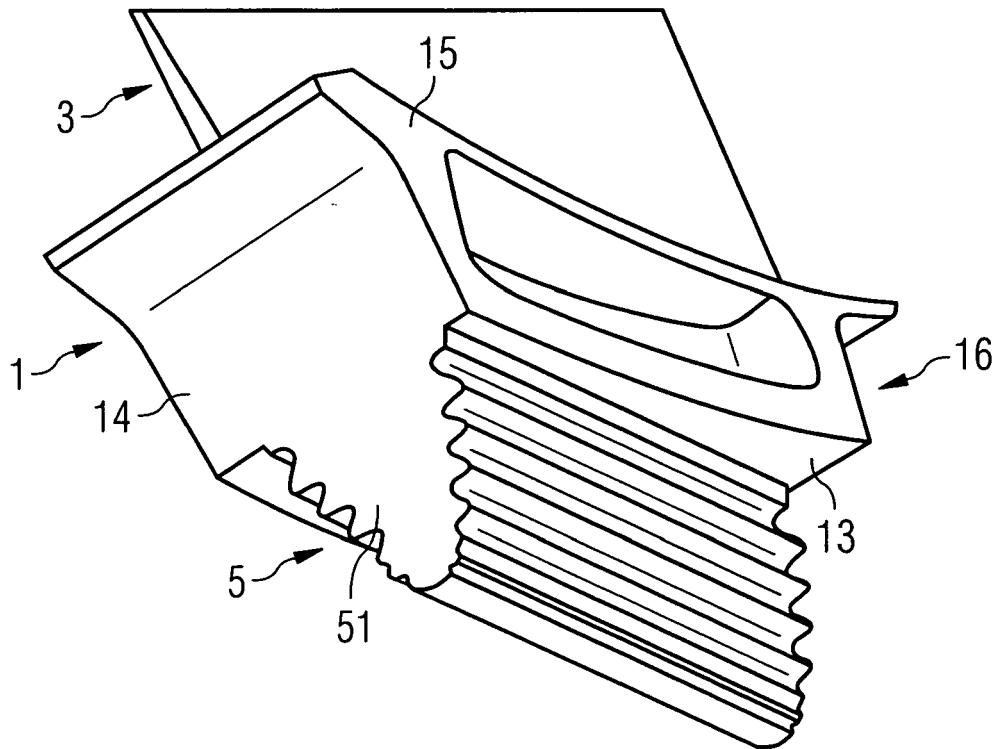
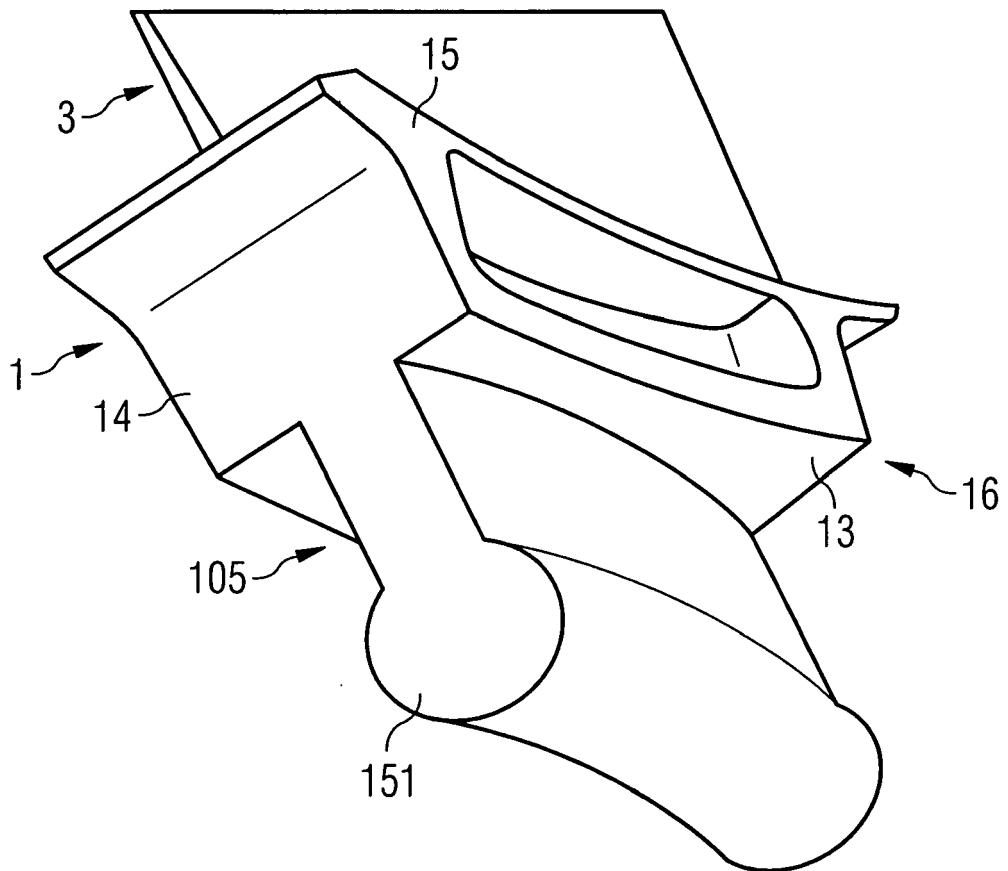

FIG 4





DOCUMENTS CONSIDERED TO BE RELEVANT			
Category	Citation of document with indication, where appropriate, of relevant passages	Relevant to claim	CLASSIFICATION OF THE APPLICATION (IPC)
X	EP 1 124 038 A (SIEMENS AG [DE]) 16 August 2001 (2001-08-16) * figures * * paragraph [0016] - paragraph [0020] * -----	1-5	INV. F01D5/12 F01D5/30
X	US 5 160 242 A (BROWN WILMOTT G [US]) 3 November 1992 (1992-11-03) * figures * * column 13, line 52 - line 57 * -----	1-5	
X	US 3 986 793 A (WARNER RONALD E ET AL) 19 October 1976 (1976-10-19) * figures * * column 4, line 57 - column 5, line 65 * -----	1-5	
A,D	US 5 242 270 A (PARTINGTON ALBERT J [US] ET AL) 7 September 1993 (1993-09-07) * the whole document * -----	1-5	
A,D	JP 07 310502 A (TOKYO SHIBAURA ELECTRIC CO) 28 November 1995 (1995-11-28) * abstract; figures * -----	1-5	TECHNICAL FIELDS SEARCHED (IPC)
A	US 1 719 415 A (GOLDIE BACK) 2 July 1929 (1929-07-02) * the whole document * -----	1-5	F01D
3 The present search report has been drawn up for all claims			
Place of search Munich		Date of completion of the search 23 October 2006	Examiner Teissier, Damien
CATEGORY OF CITED DOCUMENTS X : particularly relevant if taken alone Y : particularly relevant if combined with another document of the same category A : technological background O : non-written disclosure P : intermediate document		T : theory or principle underlying the invention E : earlier patent document, but published on, or after the filing date D : document cited in the application L : document cited for other reasons & : member of the same patent family, corresponding document	

ANNEX TO THE EUROPEAN SEARCH REPORT
ON EUROPEAN PATENT APPLICATION NO.

EP 06 01 9003

This annex lists the patent family members relating to the patent documents cited in the above-mentioned European search report. The members are as contained in the European Patent Office EDP file on
The European Patent Office is in no way liable for these particulars which are merely given for the purpose of information.

23-10-2006

Patent document cited in search report		Publication date	Patent family member(s)	Publication date
EP 1124038	A	16-08-2001	CN 1398322 A	19-02-2003
			WO 0159263 A2	16-08-2001
			JP 2003522872 T	29-07-2003
			US 2003012654 A1	16-01-2003

US 5160242	A	03-11-1992	CA 2070099 A1	01-12-1992
			JP 5149104 A	15-06-1993
			KR 227052 B1	15-10-1999

US 3986793	A	19-10-1976	BE 834920 A1	28-04-1976
			CA 1034871 A1	18-07-1978
			CH 601646 A5	14-07-1978
			DE 2544952 A1	06-05-1976
			ES 441838 A1	16-06-1977
			FR 2289727 A1	28-05-1976
			GB 1482308 A	10-08-1977
			IT 1043690 B	29-02-1980
			JP 978392 C	29-11-1979
			JP 52001202 A	07-01-1977
			JP 54010043 B	01-05-1979
			NL 7510469 A	04-05-1976
			SE 410487 B	15-10-1979
SE 7512117 A	30-04-1976			

US 5242270	A	07-09-1993	CA 2088472 A1	01-08-1993
			ES 2095790 A1	16-02-1997
			IT 1263641 B	27-08-1996
			JP 5256101 A	05-10-1993
			KR 269525 B1	01-11-2000

JP 7310502	A	28-11-1995	NONE	

US 1719415	A	02-07-1929	DE 532308 C	27-08-1931
			FR 660302 A	10-07-1929
			GB 297090 A	14-02-1929

EPO FORM P0459

For more details about this annex : see Official Journal of the European Patent Office, No. 12/82

REFERENCES CITED IN THE DESCRIPTION

This list of references cited by the applicant is for the reader's convenience only. It does not form part of the European patent document. Even though great care has been taken in compiling the references, errors or omissions cannot be excluded and the EPO disclaims all liability in this regard.

Patent documents cited in the description

- US 5242270 A **[0002]**
- JP 07310502 B **[0002]**
- EP 0486489 B1 **[0020]**
- EP 0786917 B1 **[0020]**
- EP 0412397 B1 **[0020]**
- EP 1306454 A1 **[0020]**