

R. Eickemeyer,

Lathe for Turning Ovals,

No. 101,447.

Patented Apr. 5, 1870.

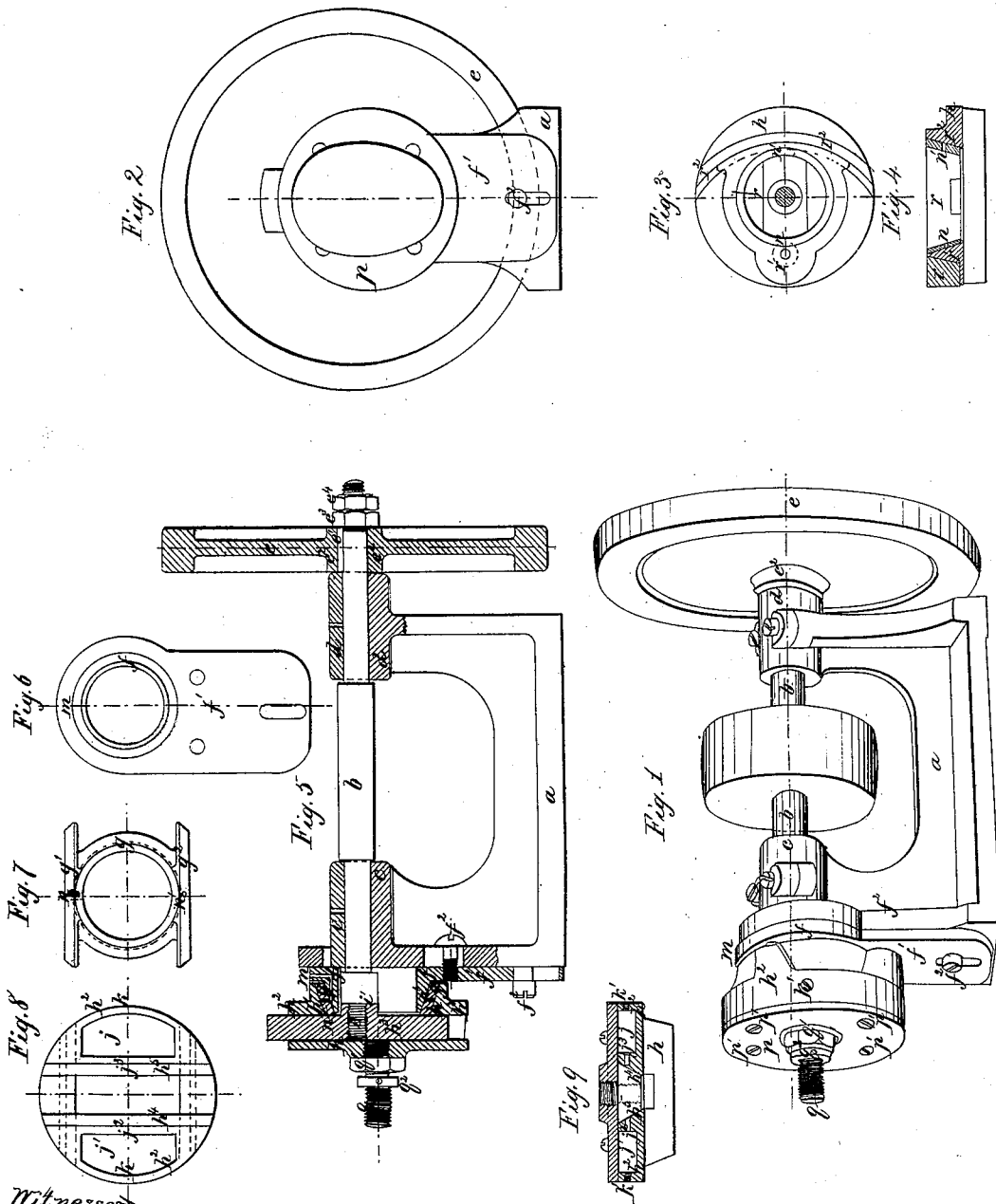

Witnessed
Hector Sitch
William Dutcher.

Inventor
R. Eickemeyer

United States Patent Office.

RUDOLF EICKEMEYER, OF YONKERS, NEW YORK.

Letters Patent No. 101,447, dated April 5, 1870.

IMPROVEMENT IN LATHE FOR TURNING OVALS.

The Schedule referred to in these Letters Patent and making part of the same.

To all whom it may concern:

Be it known that I, RUDOLF EICKEMEYER, of Yonkers, in the county of Westchester and State of New York, have invented certain new and useful Improvements in Lathes for Turning Ovals; and I do hereby declare that the following is a true and correct description of the same, reference being had to the accompanying drawings and the letters of reference thereon.

My improved lathe for turning ovals is more especially designed for turning hat-blocks of an oval form, and for rotating oval hat-blocks, with hats upon them, for the operation of pouncing.

In the manufacture of hats it is desirable to have the hat-blocks made of an irregular oval shape, similar to the section of an egg, commonly called an egg-oval, but turning lathes for turning ovals, which consist of a lathe-spindle combined with an eccentric and transverse slides in the chuck or head, will only turn regular ovals or ellipses of different diameters of a regular figure.

In order to avoid the use of patterns for turning hat-blocks of an egg-oval shape, I have invented an improvement in the ordinary oval-lathe whereby egg-ovals may be turned as readily as ellipses.

This improvement consists in so arranging one of the slides of the lathe-head, in combination with the eccentric and the other slide and lathe-spindle, that it shall move in a curved line transversely to the right line of motion of the other slide.

Another part of my invention is applicable to lathes for turning both forms of ovals, and consists in an arrangement of inclined bearing-surfaces of the eccentric and slides, in connection with play in the lathe-spindle, and a tightening screw upon the rear of the lathe-spindle, so that any looseness caused by wear of any or all of the bearing-surfaces of the slides, eccentric or back bearing of the lathe-spindle, may be corrected simply by an adjustment of the tightening nut upon the rear of the lathe-spindle.

My invention further consists in combining with the exterior slide an oil-chamber or chambers, in the plate in which it slides, substantially as hereinafter described.

Also in the arrangement of an oil-passage through the eccentric, communicating with oil-passages to the bearing-surfaces of the inner slide, substantially as hereinafter described.

In pouncing hats upon oval hat-blocks different-sized blocks, corresponding with different-sized hats, are used, and when they are screwed upon a mandrel, or screw-chuck, they are not certain to come to their exact proper position when screwed home upon the chucks upon which they were turned, owing to the wear of the wood. To remedy this difficulty I have combined with the oval head an adjustable chucking-

screw, provided with a binding-nut, so that different blocks may be readily adjusted to the proper point to correspond with the oval head by an adjustment of the chucking-screw.

But more particularly to describe my said invention I will refer to the accompanying drawings, of which—

Figure 1 represents a perspective view of a lathe-head for turning egg-ovals.

Figure 2, a side elevation of the same; showing also a front view of the egg-oval hat-block, which is left off in fig. 1 in order to show the adjustable chucking-screw.

Figure 3, a plan view of the curved slide.

Figure 4, a section of same through section-line x , fig. 3.

Figure 5 is a vertical longitudinal section through the lathe-heads, showing slides adapted to turning regular ovals.

Figure 6, a detached view of the eccentric and its fastening-plate.

Figure 7, a detached plan view of inner slide.

Figure 8, a detached plan view of plate and oil-chambers for the outer slide.

Figure 9, a section through section-line $y y$, fig. 8. Letter a represents the frame of the head of the lathe.

b , the lathe-spindle.

c , the front bearing of the lathe-spindle.

d , the back bearing of the lathe-spindle.

e , balance-wheel fitted to the lathe-spindle by a spline e' . The hub e'' of the balance-wheel serves as an adjustable collar to the spindle, and bears upon the end of the box or back bearing of the lathe-spindle, being screwed up to it by an adjusting-nut, e'' , which is held fast when adjusted by a binding-nut, e' .

It will be observed on inspection of the drawing, fig. 5, that the distance between the shoulders upon the lathe-spindle is less than the distance between the front bearing c and the back bearing d , thus leaving a play between the shoulder of the lathe-spindle and the back bearing, to permit of the spindle being drawn backward by the adjusting-nut e'' . This is the provision for tightening up the bearing-surfaces of the slides and eccentric.

Letter f is the eccentric ring, which has conical bearing-surfaces, and is secured by means of its fastening-plate, f^1 , to the front of the lathe-head, in such eccentric position with reference to the spindle as may be desired, by means of screws, f^2 .

The inner slide, g , is fitted by its conical ring to the conical bearing-surface of the eccentric, and the bearing-surfaces of its slides, g^1 , g^2 , are also inclined in the same direction as the conical surface of the eccentric, and fitted to corresponding inclined bearing-surfaces, h , h^1 , in the plate h^2 , which carries the outer slide, h^3 ,

which has also inclined bearing or sliding-surfaces, fitted to corresponding inclined bearing-surfaces, h^4 h^3 , in the plate h^2 , and is secured to the lathe-spindle by a screw, i , cut upon the end of the spindle. The arrangement of the inclined bearing-surfaces of the eccentric, the two slides, and the plate which carries the outer slide, is such that when the outer slide is screwed fast to the lathe-spindle by screwing it up to the shoulder v , all the bearings of the slides and eccentrics may be tightened or loosened by moving the lathe-spindle backward or forward in its bearings.

This may be done in any convenient manner that will admit of retaining the lathe-spindle in the position to which it is adjusted, but I prefer to use the adjusting-nut e^1 , and adjustable collar or wheel-hub e^2 , at the rear end of the spindle-shaft, as above described.

Letters $j j^1$ represent oil-chambers in the plate h^2 , which communicate by oil-holes, j^2 , j^3 , with the surfaces of the outer slide, h^2 . Oil is supplied to the chambers when required through exterior holes, k , in the periphery of the plate h^2 , which should be closed with screws, k , or plugged up in any suitable manner.

The oil-chambers should be crammed with lamp-wick, with strands introduced into the oil holes. To oil the inner slide I make an oil-hole, m , in the top of the eccentric which passes downward and then horizontally, coming out through the conical surface of eccentric ring, to oil the inner bearing surfaces of the ring of the inner slide and the eccentric, the oil for oiling the slides of the inner slide passing through oil-holes $n n'$ in said slides, opposite to each other and communicating during some part of the revolution of the inner slide around the eccentric ring with the oil-holes in the eccentric ring.

The plate p , which carries the chucking-screw, is secured to the plate h^2 by screws, p^1 , fig. 1. The chucking-screw q is screwed into the plate p , and secured in position by the binding-nut q^1 . There is a collar, q^2 , upon the chucking-screws, furnished with pin-holes, for a pin-wrench, by which the chucking-screw may be turned in its screw-hole in the plate p , when relieved from the pressure of the binding-nut q^1 , so that a hat-block, or other oval form, which has before been turned upon the lathe, may be again chucked and adjusted to its proper position for pouncing hats, or for being again operated upon by the turning-tool.

So far this description has referred more particularly to the slides for turning regular ovals or ellipses. I now proceed to describe the modification for turning egg-shaped ovals, shown in figs. 1, 3, and 4.

In this modification all the parts of the lathe are the same as the lathe for turning regular ovals above described, except that the inner slide oscillates in a curved line across the line of motion of the outer slide.

In fig. 3 r represents the oscillating inner slide which oscillates upon a conical pin, r^1 , projecting from the plate h^2 , and has conical bearing-surfaces fitted to the conical bearing-surfaces of the eccentric ring, and to the conical bearing-surfaces of the curved guide r^2 upon the plate h . Instead of the conical pin a curved guide with conical surfaces may be used, or any other suitable mechanical means for giving the slide a curvilinear motion, substantially as shown.

I have described this part of my invention as adapted to be used with my other improvements of means for adjusting all the bearing-surfaces of the slides and eccentric by the adjusting-nut at the back end of the spindle, but I do not wish to limit this part of my invention to the special arrangement of the bearings or working-surfaces of the curved slide herein shown, although I consider it the best mode of construction, as it is obvious that this improvement of

the curved slide may be adapted to the various other forms of eccentric lathes for turning ovals now in use.

Instead of placing the adjusting-nut and collar used for tightening up the working-surfaces of the slides and eccentric, at the back end of the spindle, it may be placed upon the spindle just behind the front bearing, c , and produce the same effect, there being sufficient play between the collar on the front end of the spindle and the front face of the front bearing of the spindle to allow the spindle to be drawn backward, but it is better to place the adjusting-nut and collar, or wheel-hub, at the back end of the spindle as above described.

In order to use my improvement of the oscillating inner slide for turning, it is necessary to bring the center of the eccentric f opposite to the cutting point of the turning-tool, so that a line drawn from the cutting point of the tool through the center of the lathe-spindle will strike the center of the eccentric. If the center of the eccentric is between the point of the tool and the lathe-spindle the figure produced will have a short straight axis and a long curved axis, and will resemble a bean in shape. When the center of the lathe-spindle is in line between the tool-point and the center of the eccentric, the figure produced has a long straight axis and a short curved axis, and will in this way form what is generally called an egg-oval by hatters.

The lathe as shown in the drawings is set for pouncing hats, and the point where the operator applies the pouncing or emery paper with his hand to pounce the hat is on the top of the block, directly over the lathe-center, and to use the lathe without any alteration for turning egg-oval hat-blocks, it will only be necessary to hold the tool in the same position, *i. e.*, pointing downward from a point directly over the axis of the lathe-spindle. The distance between the center of the lathe and the center of the eccentric regulates the distance between the two axes of the hat-block.

I claim as of my invention and improvement in eccentric lathes for turning ovals—

1. In combination with the lathe-spindle, eccentric, and a slide having motion in a right line, the oscillating slide, or slide moving in a curved line transversely to the motion of the other slide, substantially as described.

2. The combination of the eccentric, slides, and plates of the oval or eccentric chuck, having inclined bearing-surfaces, with each other and the lathe-spindle, substantially as described, whereby all the bearing-surfaces are tightened or loosened by moving the spindle backward or forward in its bearings, substantially as described.

3. In combination with the lathe-spindle, eccentric, slides, and plate, having conical or inclined bearing-surfaces arranged, substantially as described, the adjustable collar or wheel-hub, and adjusting-nut placed upon the spindle, whereby the parts of the eccentric, or oval chuck, are held together, and their bearing surfaces adjusted to compensate for wear, substantially as described.

4. The oil-chambers, or either of them, placed in the plate p , and the oil-holes leading from them, or either of them, in combination with the outer slide of an eccentric or oval chuck, substantially as described.

5. The oil passage m through the eccentric, in combination with the inner slide and oil-holes $n n'$ through the same, substantially as described.

6. The adjustable chucking-screw q , with its collar, q^2 , and binding-nut, q^1 , in combination with an eccentric chuck for turning ovals, substantially as described.

Witnesses:

THEODORE FITCH,
FILLMORE DUTCHER.

R. EICKEMEYER.