

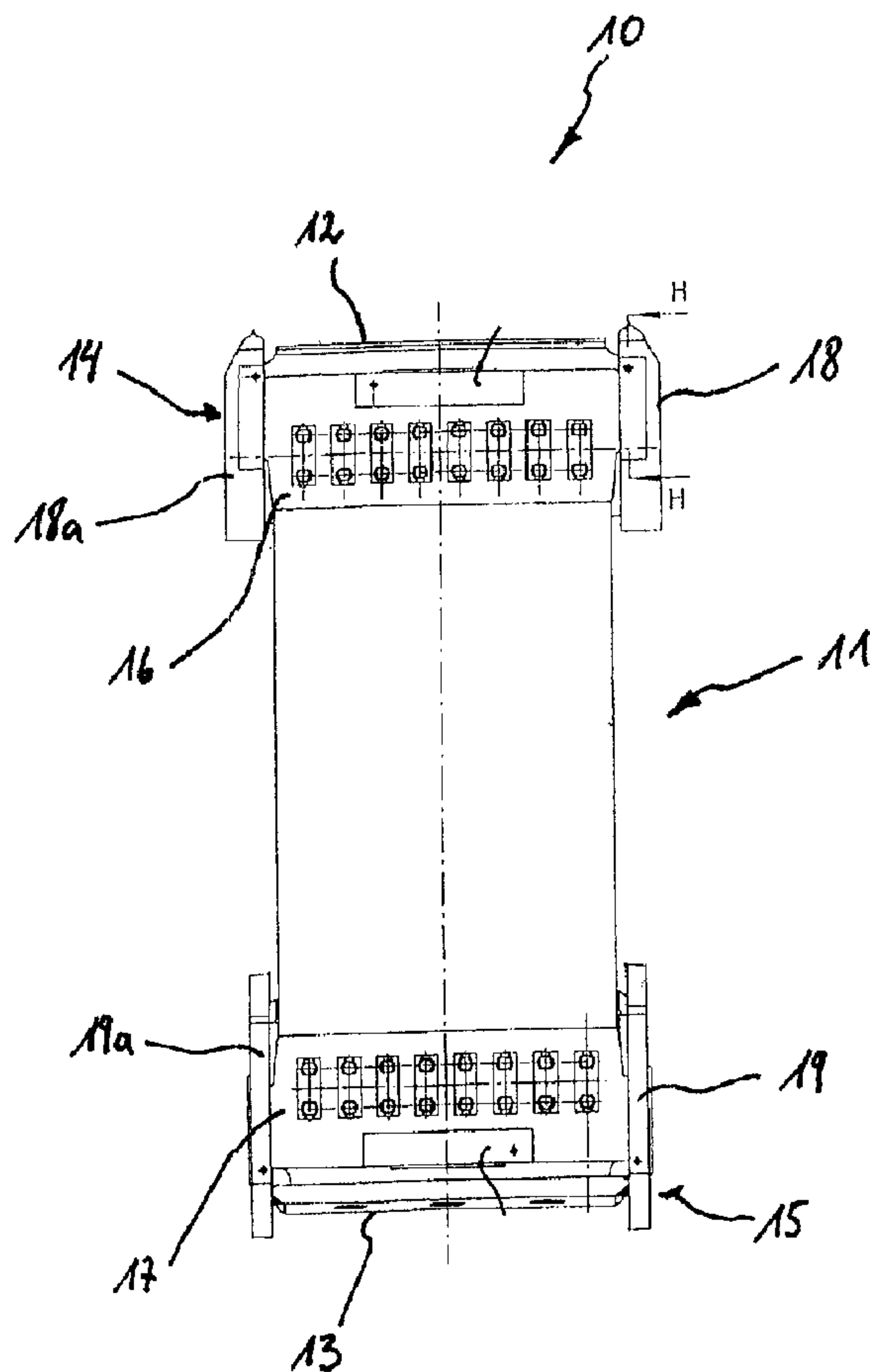

(86) Date de dépôt PCT/PCT Filing Date: 2010/11/24
 (87) Date publication PCT/PCT Publication Date: 2011/06/03
 (45) Date de délivrance/Issue Date: 2013/08/13
 (85) Entrée phase nationale/National Entry: 2012/04/10
 (86) N° demande PCT/PCT Application No.: EP 2010/068087
 (87) N° publication PCT/PCT Publication No.: 2011/064233
 (30) Priorité/Priority: 2009/11/28 (DE10 2009 056 219.2)

(51) Cl.Int./Int.Cl. *C21C 5/46* (2006.01),
F27B 3/06 (2006.01)
 (72) Inventeurs/Inventors:
BEST, ROLF, DE;
BERENS, MARTINA, DE
 (73) Propriétaire/Owner:
SMS SIEMAG AKTIENGESELLSCHAFT, DE
 (74) Agent: RICHES, MCKENZIE & HERBERT LLP

(54) Titre : SYSTEME DE FIXATION POUR RECIPIENTS METALLURGIQUES
 (54) Title: FASTENING SYSTEM FOR TILTABLE METALLURGICAL VESSELS



(57) Abrégé/Abstract:

The invention relates to a fastening system for tiltable metallurgical processing vessels, in particular converters, the processing vessel (1) being mounted in a carrier ring (2) connected to the jacket of the processing vessel by means of plate fin elements (11),



(57) **Abrégé(suite)/Abstract(continued):**

each plate fin element consisting of a plate fin connected to the carrier ring (2) by means of a sheet metal connector (16) and a first fastening bracket (14) and connected to the jacket of the processing vessel by means of a further sheet metal connector (17) and a second fastening bracket (15). According to the invention, the sheet metal connector (16, 17) is clamped by a wedge (20) between the flanges (18, 18a and 19, 19a, respectively) of the fastening bracket (14 and 15, respectively) with zero clearance, said bracket in turn abutting a tab (22) welded to the flanges of the fastening bracket and bridging same. The wedge (20) is actively connected to the tab (22) by means of a bolted connection (21).

(12) NACH DEM VERTRAG ÜBER DIE INTERNATIONALE ZUSAMMENARBEIT AUF DEM GEBIET DES PATENTWESENS (PCT) VERÖFFENTLICHTE INTERNATIONALE ANMELDUNG

(19) Weltorganisation für geistiges Eigentum
Internationales Büro(43) Internationales Veröffentlichungsdatum
3. Juni 2011 (03.06.2011)(10) Internationale Veröffentlichungsnummer
WO 2011/064233 A3

- (51) Internationale Patentklassifikation:
C21C 5/46 (2006.01) F27B 3/06 (2006.01)
- (74) Anwalt: KLÜPPEL, Walter; Hammerstr.2, 57072 Siegen (DE).
- (21) Internationales Aktenzeichen: PCT/EP2010/068087
- (81) Bestimmungsstaaten (soweit nicht anders angegeben, für jede verfügbare nationale Schutzrechtsart): AE, AG, AL, AM, AO, AT, AU, AZ, BA, BB, BG, BH, BR, BW, BY, BZ, CA, CH, CL, CN, CO, CR, CU, CZ, DK, DM, DO, DZ, EC, EE, EG, ES, FI, GB, GD, GE, GH, GM, GT, HN, HR, HU, ID, IL, IN, IS, JP, KE, KG, KM, KN, KP, KR, KZ, LA, LC, LK, LR, LS, LT, LU, LY, MA, MD, ME, MG, MK, MN, MW, MX, MY, MZ, NA, NG, NI, NO, NZ, OM, PE, PG, PH, PL, PT, RO, RS, RU, SC, SD, SE, SG, SK, SL, SM, ST, SV, SY, TH, TJ, TM, TN, TR, TT, TZ, UA, UG, US, UZ, VC, VN, ZA, ZM, ZW.
- (22) Internationales Anmeldedatum:
24. November 2010 (24.11.2010)
- (84) Bestimmungsstaaten (soweit nicht anders angegeben, für jede verfügbare regionale Schutzrechtsart): ARIPO (BW, GH, GM, KE, LR, LS, MW, MZ, NA, SD, SL, SZ, TZ, UG, ZM, ZW), eurasisches (AM, AZ, BY, KG, KZ, MD, RU, TJ, TM), europäisches (AL, AT, BE, BG, CH, CY, CZ, DE, DK, EE, ES, FI, FR, GB, GR, HR, HU, IE, IS, IT, LT, LU, LV, MC, MK, MT, NL, NO, PL, PT, RO,
- (25) Einreichungssprache: Deutsch
- (26) Veröffentlichungssprache: Deutsch
- (30) Angaben zur Priorität:
10 2009 056 219.2
28. November 2009 (28.11.2009) DE
- (71) Anmelder (für alle Bestimmungsstaaten mit Ausnahme von US): SMS SIEMAG AG [DE/DE]; Eduard-Schloemann-Straße 4, 40237 Düsseldorf (DE).
- (72) Erfinder; und
- (75) Erfinder/Anmelder (nur für US): BEST, Rolf [DE/DE]; Partnerschaftsweg 23, 45966 Gladbeck (DE). BERENS, Martina [DE/DE]; Wiesenstraße 14, 46499 Hamminkeln (DE).

[Fortsetzung auf der nächsten Seite]

(54) Title: FASTENING SYSTEM FOR TILTABLE METALLURGICAL VESSELS

(54) Bezeichnung : BEFESTIGUNGSSYSTEM FÜR KIPPBARE METALLURGISCHE GEFÄSSE

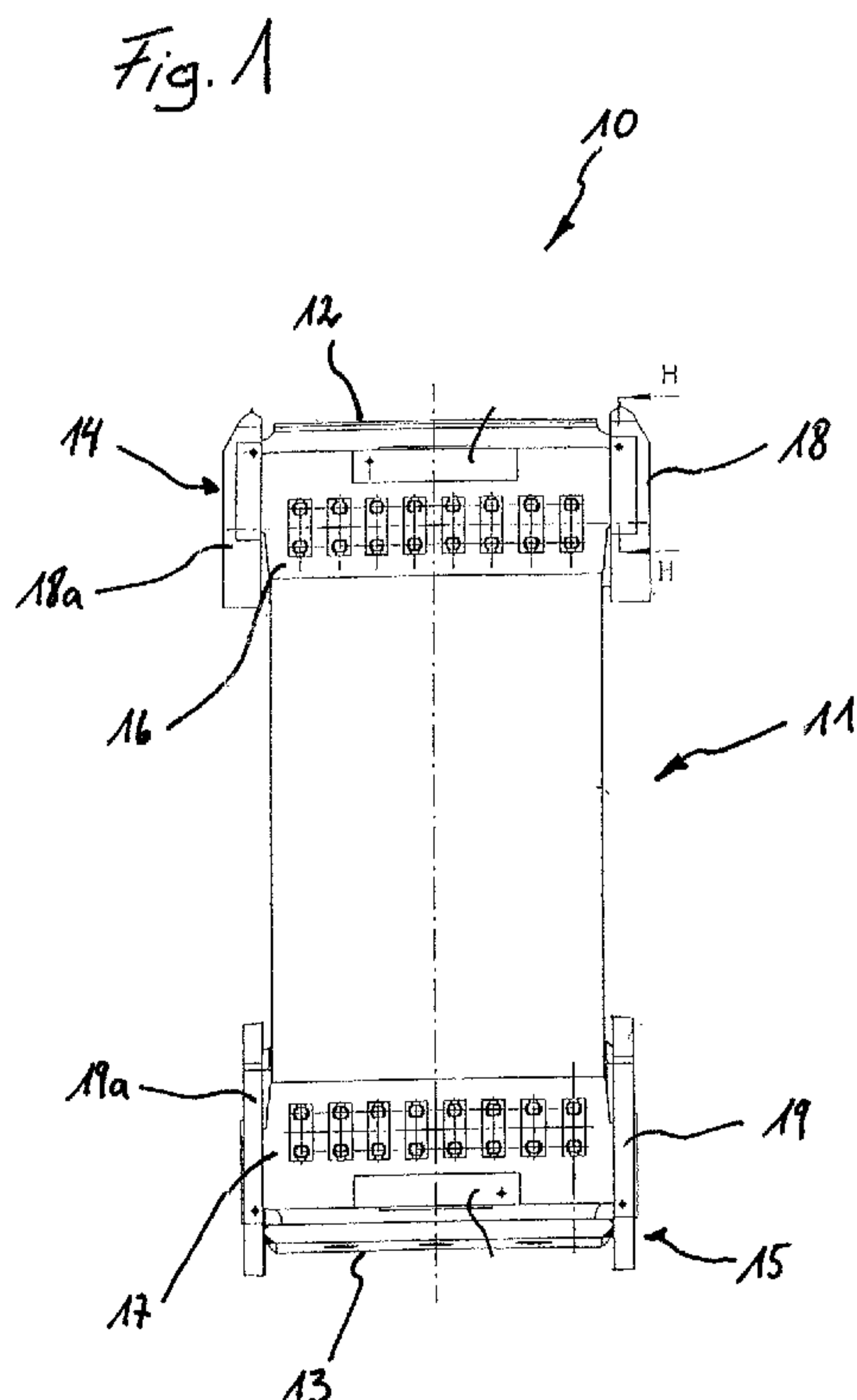

(57) Abstract: The invention relates to a fastening system for tiltable metallurgical processing vessels, in particular converters, the processing vessel (1) being mounted in a carrier ring (2) connected to the jacket of the processing vessel by means of plate fin elements (11), each plate fin element consisting of a plate fin connected to the carrier ring (2) by means of a sheet metal connector (16) and a first fastening bracket (14) and connected to the jacket of the processing vessel by means of a further sheet metal connector (17) and a second fastening bracket (15). According to the invention, the sheet metal connector (16, 17) is clamped by a wedge (20) between the flanges (18, 18a and 19, 19a, respectively) of the fastening bracket (14 and 15, respectively) with zero clearance, said bracket in turn abutting a tab (22) welded to the flanges of the fastening bracket and bridging same. The wedge (20) is actively connected to the tab (22) by means of a bolted connection (21).

(57) Zusammenfassung: Die Erfindung betrifft ein Befestigungssystem für kippbare metallurgische Behandlungsgefäße, insbesondere Konverter, wobei das Behandlungsgefäß (1) in einem Tragring (2) gelagert ist, der über Lamellenelemente (11) mit dem Behandlungsgefäßmantel verbunden ist, wobei jedes Lamellenelement aus einer Lamelle besteht, die über ein Anschlussblech (16) und eine erste Befestigungskonsole (14) mit dem Tragring (2) und über ein weiteres Anschlussblech

[Fortsetzung auf der nächsten Seite]

WO 2011/064233 A3



RS, SE, SI, SK, SM, TR), OAPI (BF, BJ, CF, CG, CI, CM, GA, GN, GQ, GW, ML, MR, NE, SN, TD, TG).

(88) Veröffentlichungsdatum des internationalen Recherchenberichts:

22. September 2011

Veröffentlicht:

— mit internationalem Recherchenbericht (Artikel 21 Absatz 3)

(17) und eine zweite Befestigungskonsole (15) mit dem Behandlungsgefäßmantel verbunden ist. Dabei ist vorgesehen, dass das Anschlussblech (16,17) durch einen Keil (20) zwischen den Wangen (18,18a bzw.19,19a) der Befestigungskonsole (14 bzw.15) spielfrei eingespannt ist, der seinerseits an einer Lasche (22) anliegt, die an die Wangen der Befestigungskonsole, diese überspannend, angeschweißt ist. Der Keil (20) ist durch eine Schraubverbindung (21) mit der Lasche (22) wirkverbunden.

Fastening System for Tilttable Metallurgical Vessels

The invention relates to a fastening system for tilttable metallurgical treatment vessels, particularly converters, wherein the treatment vessel is supported in a support ring which is connected through plate-like elements to the treatment vessel casing, wherein each element consists of a plate which is connected to the support ring through an end plate and a first fastening bracket, and which is connected to the treatment vessel casing through another end plate and a second fastening bracket.

Converters are rotatable metallurgical reaction vessels for refining the liquid pig iron. Because of the high temperatures, thermal expansion causes problems in the mounting of the treatment vessel.

In order to be able to compensate for the thermal expansion and to still be able to ensure a seat without play of the conveyer in its support ring, DE 19 03 685 proposes a fastening system with support strips between support ring and converter casing. In this connection, the support strips have

the purpose of facilitating relative movement of converter and support ring.

EP 1 061 138 B1 also discloses a vessel suspension for a converter, wherein the upper chord and the lower chord are connected to each other through releasable, frictionally engaging and positively engaging tension element connections.

When using such converters with this type of vessel fastening, there is the disadvantage that during cleaning operations, such as, for example, removing caked-on slag, the safety plates, which serve for fixing the plate-like element receiving plate in the area of the lateral bracket plates, are loosened or are even torn off. If the safety plates are damaged, it is necessary to repair or replace them. This leads to increases in the costs of the necessary repairs.

Therefore, it is the object of the present invention to improve the known vessel fastenings and, thus, to avoid the aforementioned disadvantage.

In accordance with the invention, this object is met by a fastening system for tiltable metallurgical treatment vessels, particularly converters, wherein the treatment vessel is supported in a support ring which is connected to the treatment vessel casing through plate-like elements, wherein each element is composed of a thin plate which is connected to the support ring through an end plate and a first fastening bracket and which is connected to the treatment vessel casing through another end plate and a second fastening bracket, wherein the end plate is clamped by means of a wedge without play between the cheeks of the fastening bracket, wherein the wedge, in turn, rests against a lug which is welded to the cheeks of the fastening bracket so as to span over the fastening bracket, and wherein the wedge is operatively connected to the lug through a screw connection.

The screw connection includes a threaded piece for fixing the wedge without play.

The threaded piece is preferably secured by a welded seam after the wedge has been adjusted.

Consequently, in the fastening system according to the invention, the threaded piece and the lug are secured so as to prevent loss thereof. As a result, the fastening system no longer has any loose or releasable components. When mounting the plate-like elements on the support ring or the converter vessel, the individual parts can be assembled without play and are connected to each other undetachably.

Accordingly, in one aspect, the present invention provides a fastening system for a tiltable metallurgical treatment vessel, wherein the treatment vessel (1) is supported in a support ring (2) which is connected through small plate-like elements (11) to a treatment vessel casing, wherein each element is composed of a small plate which is connected through an end plate (16) and an associated first fastening bracket (14) to the support ring (2), and through another end plate (17) and an associated second fastening bracket (15) to the treatment vessel casing, wherein each said end plate (16, 17) being clamped without play by an associated wedge (20) between cheeks (18, 18a) or (19, 19a) of the fastening brackets (14 or 15), with the wedge, in turn, resting against a lug (22) which is welded to the cheeks of the associated fastening bracket so as to span over the fastening

bracket, and that the wedge (20) is operatively connected to the lug (22) through a screw connection (21).

BRIEF DESCRIPTION OF THE DRAWINGS

In the following the invention will be explained in more detail with the aid of an embodiment with reference to the enclosed drawing. In the drawing:

Fig. 1 is a side view of the fastening system according to the invention,

Fig. 2 is a sectional view along line H-H in Fig. 1, and

Fig. 3 schematically shows the arrangement of such a fastening system on a converter.

Initially, reference will be made to Fig. 3 which shows a metallurgical treatment vessel, in the form of a conventional converter. This converter is denoted by reference numeral 1.

In order to facilitate tilting of the converter, the converter is arranged in a support ring 2 which is supported through pins 3 in the drive system 4.

The connection between the support ring 2 and the treatment vessel casing is achieved through the fastening system 10 consisting of plate-like elements 11.

The invention is directed to the configuration of this fastening system.

As illustrated in Fig. 1, the fastening system 10 is composed of plate-like elements, wherein one of these is illustrated as an example in Fig. 1.

The plate-like element 11 is in the mounted position with its upper free end 12 and its lower free end 13 connected to a fastening bracket 14 which is the upper bracket in the mounted position, and a fastening bracket 15 which is the

lower bracket in the mounted position. The upper free end 12 and the lower free end 13 are connected to end plates 16 and 17. The end plates 16 and 17 are fitted without play in the lateral cheeks 18, 18a and 19, 19a of the fastening brackets 14 and 15.

Fig. 2 is a sectional view through the upper fastening bracket 14 along the line H-H. The end plate 16 is held by clamping and fixed by means of a wedge 20 in the cheek 18. The wedge 20 is held in a fixed position by means of a threaded piece 21, or can be initially positioned by the threaded piece.

The threaded piece 21 is constructed in this embodiment as a stud bolt. To be able to secure the wedge 20 and the end plate 16, a lug 22 extending over the cheeks is provided, wherein the lug is welded to the cheeks.

A welded seam 23 is provided on the threaded piece and the lug 22 as an additional connection.

List of Reference Numerals

1	Converter
2	Support ring
3	Pin
4	Drive
10	Fastening system
11	Plate-like element
12	Upper end
13	Lower end
14	Upper fastening bracket
15	Lower fastening bracket
16	End plate
17	End plate
18, 18a	Cheeks
19, 19a	Cheeks

- 20 Wedge
- 21 Threaded piece
- 22 Lug
- 23, 23a Welded seam

WE CLAIM:

1. Fastening system for a tiltable metallurgical treatment vessel, wherein the treatment vessel (1) is supported in a support ring (2) which is connected through small plate-like elements (11) to a treatment vessel casing, wherein each element is composed of a small plate which is connected through an end plate (16) and an associated first fastening bracket (14) to the support ring (2), and through another end plate (17) and an associated second fastening bracket (15) to the treatment vessel casing, wherein

each said end plate (16, 17) being clamped without play by an associated wedge (20) between cheeks (18, 18a) or (19, 19a) of the fastening brackets (14 or 15), with the wedge, in turn, resting against a lug (22) which is welded to the cheeks of the associated fastening bracket so as to span over the fastening bracket,

and that the wedge (20) is operatively connected to the lug (22) through a screw connection (21).

2. Fastening system according to Claim 1, characterized in that

the screw connection (21) is fixable without play by the wedge.

3. Fastening system according to Claim 2, characterized in that

the screw connection includes a threaded piece, the threaded piece is secured by a welded seam (23) after the adjustment of the wedge.

4. Fastening system according to any one of claims 1 to 3, wherein said treatment vessel comprises a converter.

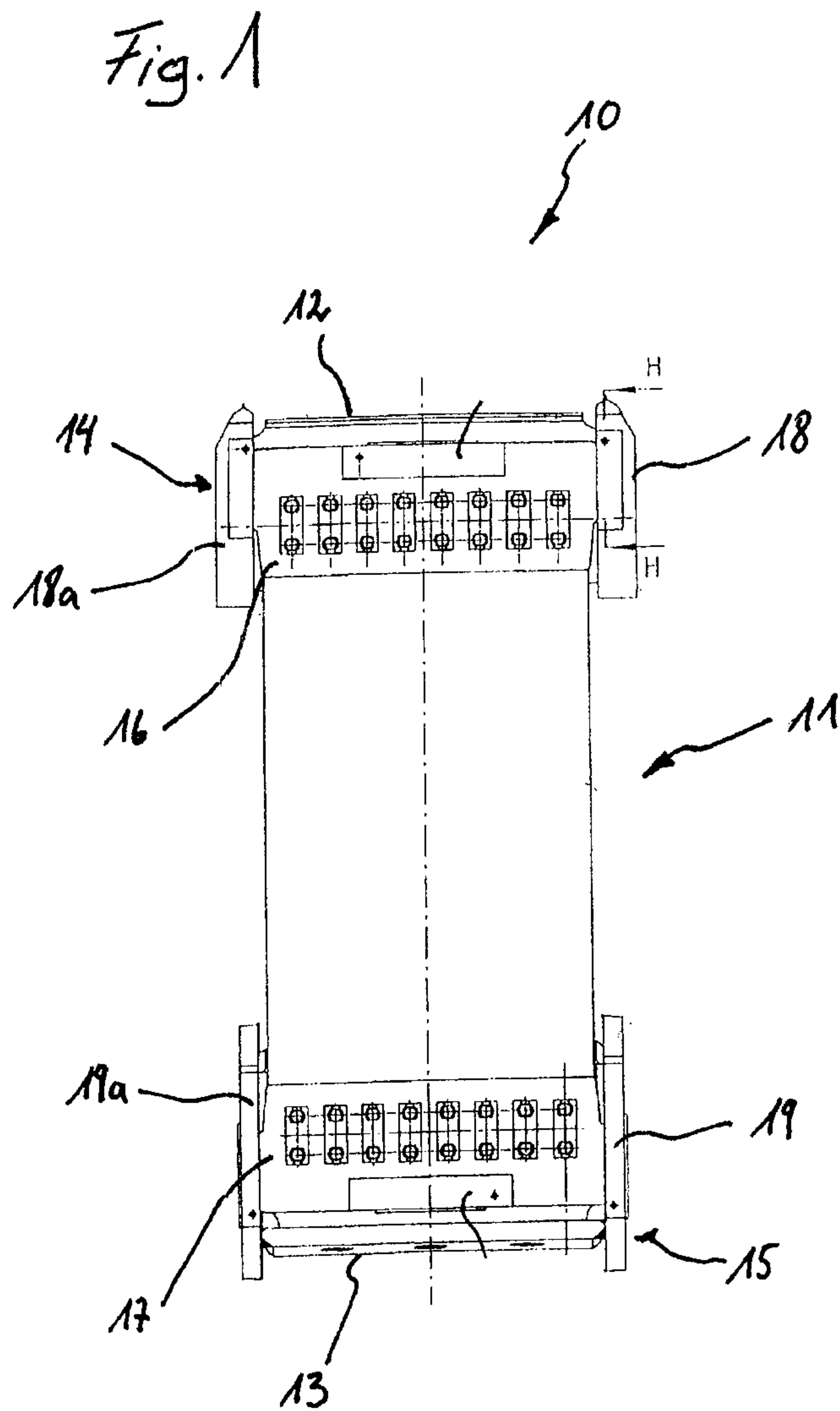
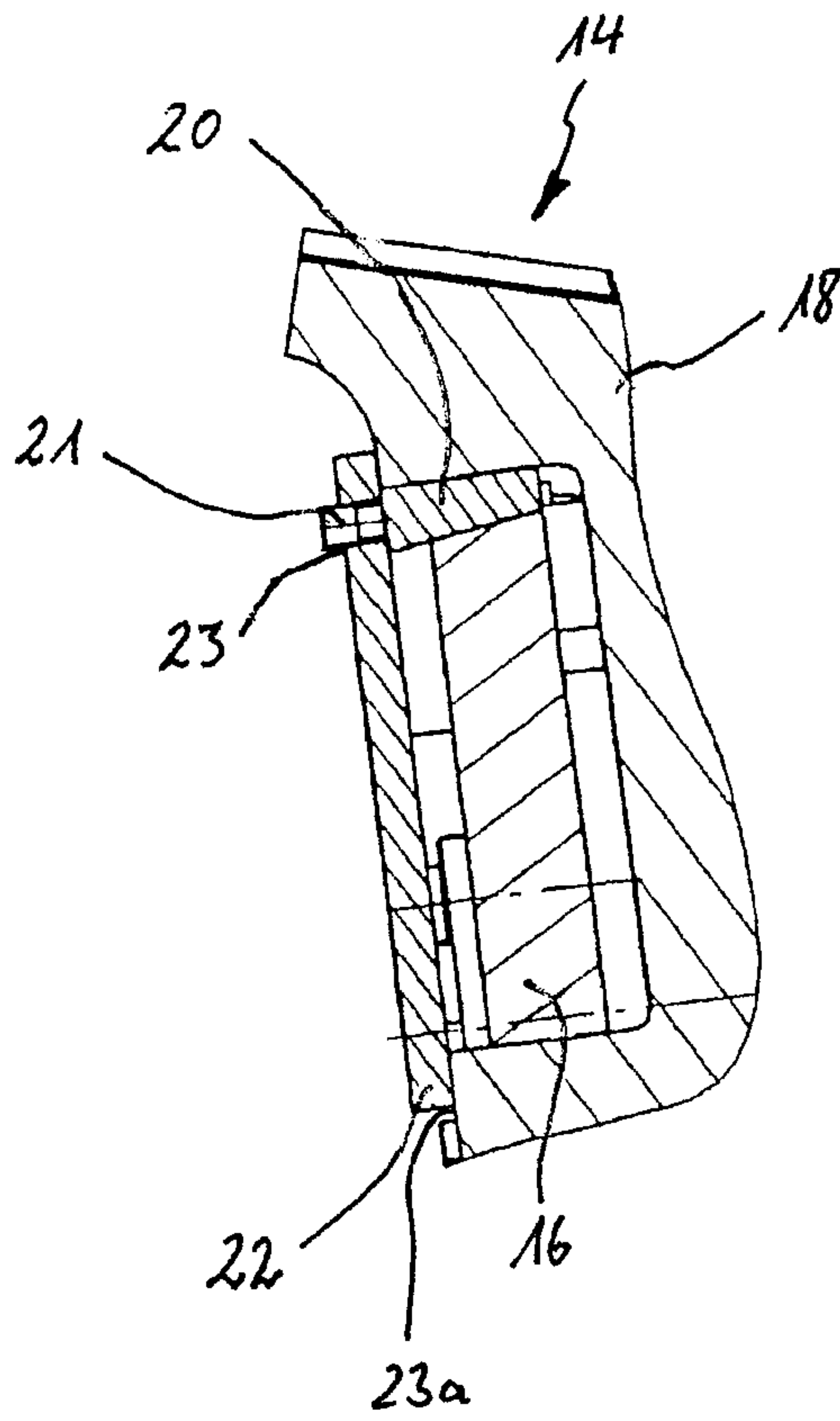

Fig. 2



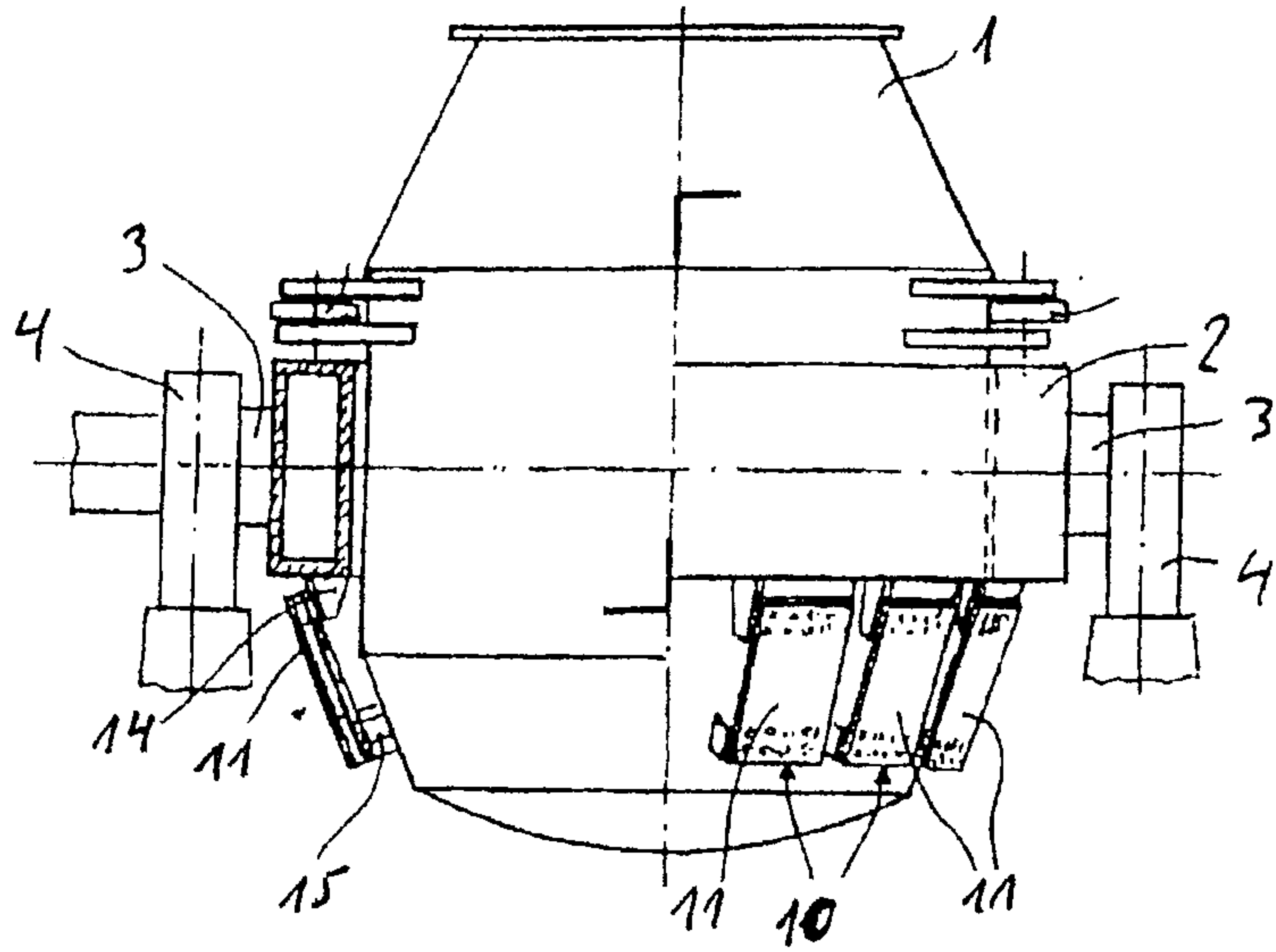
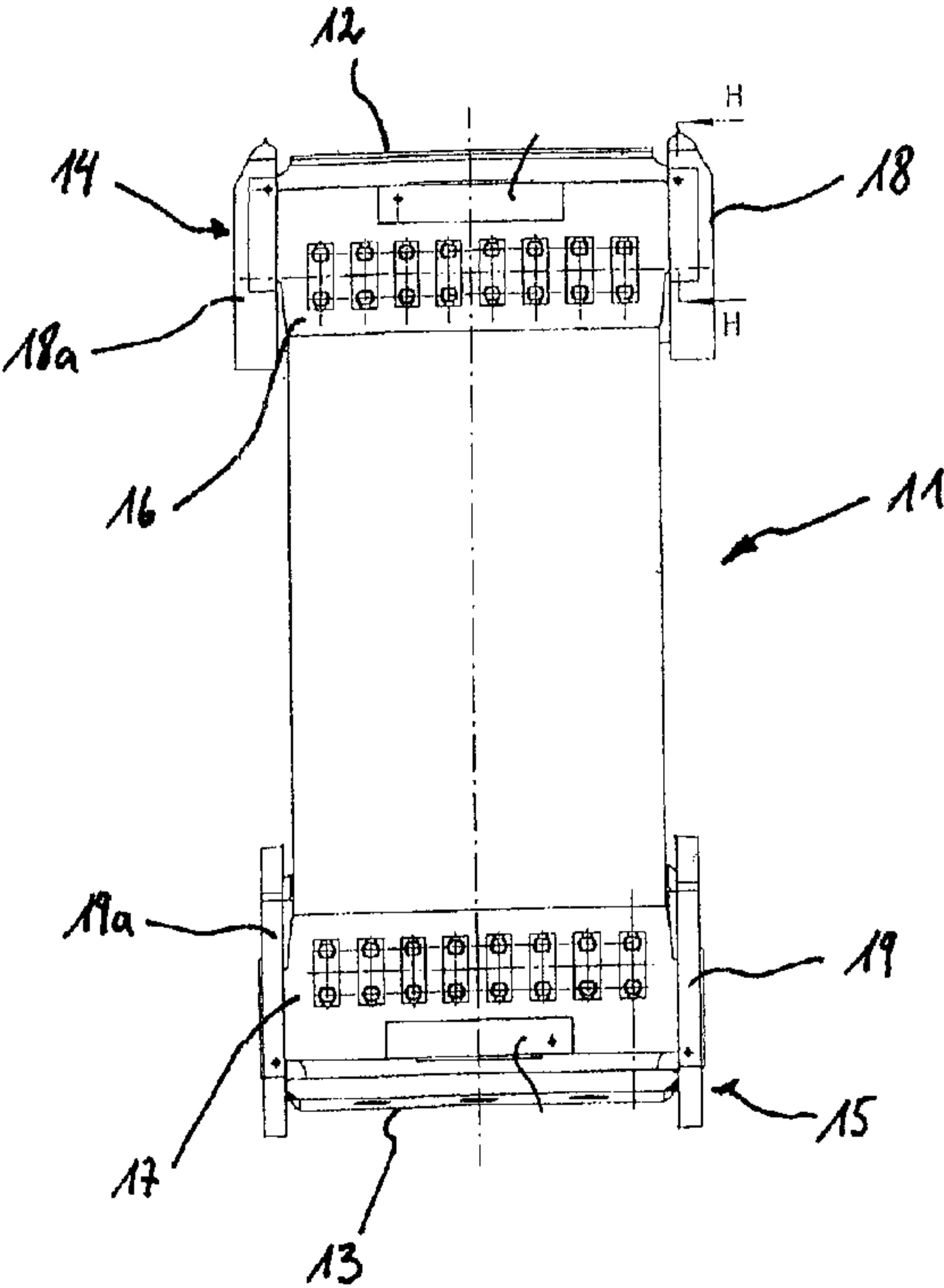

Fig. 3

10



12

H

14

18

18a

H

16

11

19a

19

17

15

13