

(19) World Intellectual Property
Organization
International Bureau



(43) International Publication Date
15 September 2005 (15.09.2005)

PCT

(10) International Publication Number
WO 2005/084335 A2

- (51) International Patent Classification: Not classified
- (74) Agents: SWARTZ, Douglas, W. et al.; Sheridan Ross P.C., 1560 Broadway, Suite 1200, Denver, CO 80202-5141 (US).
- (21) International Application Number: PCT/US2005/006740
- (81) Designated States (unless otherwise indicated, for every kind of national protection available): AE, AG, AL, AM, AT, AU, AZ, BA, BB, BG, BR, BW, BY, BZ, CA, CH, CN, CO, CR, CU, CZ, DE, DK, DM, DZ, EC, EE, EG, ES, FI, GB, GD, GE, GH, GM, HR, HU, ID, IL, IN, IS, JP, KE, KG, KP, KR, KZ, LC, LK, LR, LS, LT, LU, LV, MA, MD, MG, MK, MN, MW, MX, MZ, NA, NI, NO, NZ, OM, PG, PH, PL, PT, RO, RU, SC, SD, SE, SG, SK, SL, SM, SY, TJ, TM, TN, TR, TT, TZ, UA, UG, US, UZ, VC, VN, YU, ZA, ZM, ZW.
- (22) International Filing Date: 1 March 2005 (01.03.2005)
- (25) Filing Language: English
- (26) Publication Language: English
- (30) Priority Data:
60/549,327 1 March 2004 (01.03.2004) US
60/552,932 12 March 2004 (12.03.2004) US
- (71) Applicant (for all designated States except US): RAILPOWER TECHNOLOGIES CORP. [CA/CA]; Suite 202, 50 Fell Avenue, North Vancouver, British Columbia V7P 3S2 (CA).
- (72) Inventors; and
- (75) Inventors/Applicants (for US only): MAIER, James, E. [CA/CA]; 4380 Blue Grouse Road, Duncan, British Columbia V9L 6M3 (CA). DONNELLY, Frank, Wegner [CA/CA]; 509 East 6th Street, North Vancouver, British Columbia V7L 1R2 (CA). MACIULEWICZ, Anthony [US/US]; 2712 Rosecliff Terrace, Grapevine, TX 76051 (US). SWARTZ, Douglas, W. [US/US]; 2567 Taft Court, Lakewood, CO 80215 (US).
- (84) Designated States (unless otherwise indicated, for every kind of regional protection available): ARIPO (BW, GH, GM, KE, LS, MW, MZ, NA, SD, SL, SZ, TZ, UG, ZM, ZW), Eurasian (AM, AZ, BY, KG, KZ, MD, RU, TJ, TM), European (AT, BE, BG, CH, CY, CZ, DE, DK, EE, ES, FI, FR, GB, GR, HU, IE, IS, IT, LT, LU, MC, NL, PL, PT, RO, SE, SI, SK, TR), OAPI (BF, BJ, CF, CG, CI, CM, GA, GN, GQ, GW, ML, MR, NE, SN, TD, TG).
- Published:**
— without international search report and to be republished upon receipt of that report
- For two-letter codes and other abbreviations, refer to the "Guidance Notes on Codes and Abbreviations" appearing at the beginning of each regular issue of the PCT Gazette.

(54) Title: CABLESS HYBRID LOCOMOTIVE

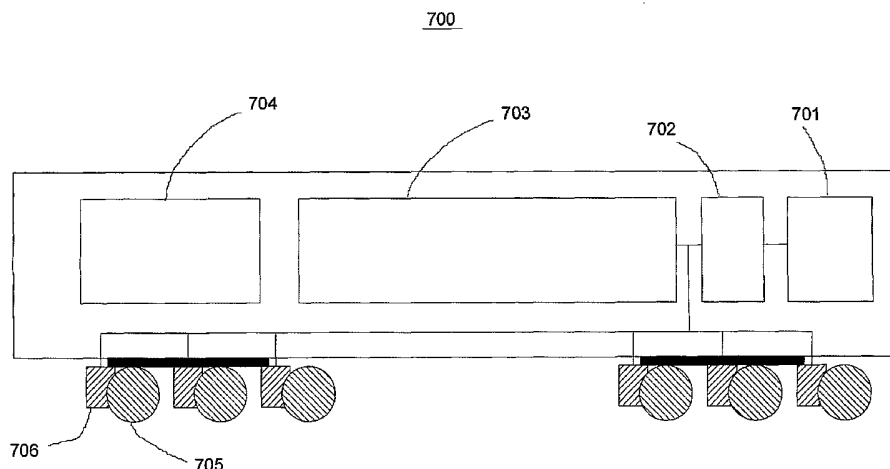

(57) Abstract: The present invention is directed to a hybrid locomotive that can operate in a multitude of operational modes, including a slug operating mode, an energy storage operating mode, an independent operating mode, and a power source operating mode, and/or can provide electrical energy to an external power distribution system, such as a power grid, catenary, and third rail.

WO 2005/084335 A2

CABLESS HYBRID LOCOMOTIVE

FIELD

The present invention relates generally to a cableless hybrid locomotive which is suitable for augmenting other locomotives as part of a locomotive consist or acting as an independent locomotive in a variety of other applications.

BACKGROUND

Conventional stand-alone locomotives have output power typically ranging from approximately 300 horsepower (for example, locomotives used in mining and tunneling) to 6,000 horsepower (for example, locomotives for long haul cross-country freight trains). In many applications, especially if there are significant grades along the route, a number of conventional locomotives may be used in a consist to haul a large train of a few to over a hundred cars.

Alternately, a consist may be composed of B-unit locomotives (a conventional locomotive without a functional cab) controlled by the crew of the lead or A-unit locomotive. Another multi-locomotive configuration might be comprised of conventional diesel locomotives and one or more slugs. A slug is a cableless locomotive that contains traction motors but has no integral prime power supply, receiving its power from another locomotive called the mother. Slugs are usually constructed from old conventional locomotives which have their cabs removed. The deactivated diesel engines may be left in place or replaced by inert ballast to maintain sufficient weight over the wheels for proper traction.

Conventional railroad locomotives are typically powered by diesel-electric systems or by diesel-hydraulic systems. It is known that a hybrid locomotive or a hybrid locomotive/tender car combination can be used to capture and store energy that is otherwise wasted by incorporating an energy storage system (battery pack, capacitor bank, flywheel assemblies or combinations of these systems). The energy storage system may be charged by an on-board engine, by another hybrid or conventional locomotive in the consist, by a regenerative braking system or by an external source. The stored energy may be used to power the traction motors of the energy storage car or the traction motors of other operative members of the consist.

US 6,408,766 discloses an auxiliary tender car for locomotives which stores significant quantities of fuel and delivers the fuel to the locomotives while underway. The

tender also includes traction motor drive axles but does not have its own power source. The traction motors of the tender car are powered by the locomotive and may also be capable of providing dynamic braking. The auxiliary tender operates much like a road slug except that it carries useful materials such as fuel instead of ballast.

5 One of the present inventors has disclosed the use of a battery-dominant hybrid locomotive in US 6,308,639 which is also incorporated herein by reference. The same inventor has also disclosed a method and apparatus for controlling power provided to DC traction motors by furnishing an individual chopper circuit for each traction motor in US 6,812,656 which is incorporated herein by reference.

10 There remains a need for a hybrid locomotive which is capable of remote operation either in concert with other locomotives or as an independently operable locomotive. Such a hybrid locomotive must be able to efficiently control available energy and effectively allocate power and tractive effort.

15 SUMMARY

These and other needs are addressed by the various embodiments and configurations of the present invention which is directed generally to a hybrid locomotive that can function in various operating modes and/or provide electrical energy to other external electrical devices.

20 In a first embodiment of the present invention, the hybrid locomotive can operate in a plurality of the following operating modes:

- a road or yard slug
- an energy storage unit for a locomotive consist
- a hybrid B-unit in a locomotive consist
- 25 an independent, remotely operated hybrid yard switching locomotive
- an independent, mobile power supply for a power grid

In one configuration, the hybrid locomotive is a cableless locomotive comprised of at least an energy storage unit, a prime power generator, an energy conversion device to convert the energy output by the primary energy source into a form suitable for storage or propulsion, 30 a supply of fuel for the prime energy source and appropriate controls, all mounted on a frame which includes two or more truck assemblies, each truck assembly being further comprised

of AC or DC traction motors each of which may be controlled by its own inverters and/or chopper circuits.

In another configuration, the cabless hybrid locomotive is additionally provided with a dynamic braking system. The dynamic braking system may also be extended to include a regeneration system for routing some or all of the energy recovered from braking to the energy storage system.

In a preferred configuration, a single cabless locomotive is configured to provide a variety of functions by manually switching between control algorithms. Under a first control algorithm, the cabless locomotive can then automatically function as a slug by drawing power from adjacent locomotives to power the traction motors on the cabless locomotive. Under a second control algorithm, the cabless locomotive can automatically function as an energy storage unit by receiving power from a regenerative braking system, its own charging power supply and/or from other members of the consist. Under a third control algorithm, the cabless locomotive can automatically function as a B-locomotive using a combination of prime movers and energy storage units to provide propulsion and braking through its traction motors. Under a fourth control algorithm, the cabless locomotive can automatically function as an independent locomotive using a combination of prime movers and energy storage units to provide propulsion through its traction motors and to receive power from a regenerative braking system. In this configuration, the locomotive may be remotely controlled or controlled from a temporary cab on the locomotive. Under a fifth control algorithm, the cabless locomotive can automatically function as a power supply or power regulator for a power grid, catenary or third rail using a combination of prime movers and energy storage units to provide or receive power through a power conditioning apparatus.

In another embodiment, a number of cabless hybrid locomotives can form a part of a locomotive consist where the operation of each cabless hybrid locomotive has one or more independently controllable features. These independently controllable features may include, for example, the total amount of tractive effort applied, the operation of the prime power sources, the amount of stored energy used, the amount of power applied by either or both of the prime power sources and energy storage systems, control of wheel slip, control of wheel skid, amount of regenerative braking energy stored and amount of energy transferred to other locomotives in the consist. Independent control of features such as described above can be

5 effected by predetermined or programmable logic in an on-board programmable logic controller, a microcomputer, an industrial computer or the like. Control may also be accomplished for each cabless hybrid locomotive in the consist from the A unit locomotive, or from the A unit locomotive to the adjacent B unit locomotive and then daisy-chained from each neighboring B unit locomotive to the next utilizing predetermined or programmable logic in on-board programmable logic controllers, microcomputers, industrial computers or the like. Control may be by any number of communication methods such as for example, by hard wire from locomotive to locomotive, radio telemetry, other forms of wireless communication, and/or audio and/or video linkage telemetry. If energy is transferred from locomotive to locomotive in the consist, the locomotives will require hard wire connections.

10 In another embodiment, the appropriate controls can be operated remotely by an operator who is located on the locomotive itself or on any of the cars that form the train; or, more typically, the operator can be located externally to the cabless hybrid locomotive and the cars that form the train propelled by one or more cabless locomotives. In this case, the cabless hybrid locomotive can be independently operable by an operator on foot, in a vehicle not connected to the train being pulled by the cabless hybrid locomotive, or in a building. In these instances, the operator could control the cabless hybrid locomotive of the present invention by any number of remote control techniques, such as for example, a belt controller, radio telemetry, other forms of wireless communication, and/or audio and/or video linkage.

15 In another embodiment, the cabless hybrid locomotive can be operated in fully automated mode using a computer program. Such operation is preferred in operations that are repetitive and/or in dangerous areas such as radioactive mining or waste storage.

20 In yet another embodiment, a method is provided for managing the energy states of members of a consist. The consist members can be any energy consuming and/or providing vehicles, such as a hybrid locomotive, a conventional diesel locomotive, a slug, a tender car, a B-locomotive, an A-locomotive, and the like. In one configuration, one of the members is a hybrid locomotive including an energy storage unit for storing electrical energy, and a generator for providing electrical energy to the energy storage unit or its traction motors.

25 In another configuration, one of the members is a hybrid locomotive including an energy storage unit for storing electrical energy, a generator for providing electrical energy to the energy storage unit or its traction motors and a regenerative braking system for some

30

or all of its electrical energy to the energy storage unit. The consist members are interconnected by a direct current power bus for exchanging electrical energy.

The method for controlling the hybrid locomotive includes the steps:

5 (a) for the locomotive, monitoring the voltages and currents associated with the energy storage unit, generator(s), and one or more of the traction motors, as well as monitoring the revolutions-per-minute of the generator(s) and one or more of the traction motors; and

(b) for the locomotive, using the results of the monitoring step to select from among at least the following discrete operational modes or energy states:

10 (i) in a first operational mode, powering the plurality of traction motors of the locomotive using predominantly electrical energy from one or more other members of the consist. In this first operational mode, the locomotive stores more energy in the energy storage unit than is being removed from the energy storage unit. In this mode, electrical energy is not being provided by the locomotive to another consist member;

15 (ii) in a second operational mode, powering the plurality of traction motors of the locomotive using predominantly electrical energy from the locomotive's own energy storage unit and/or generator. In this second operational mode, the amount of electrical energy stored in the locomotive's electrical storage unit is less than the amount of electrical energy removed from the locomotive's energy storage unit. In this mode, the electrical energy is not being provided by the locomotive to another consist member;

20 (iii) in a third operational mode, storing electrical energy in the locomotive's energy storage unit. In this third operational mode, most of the electrical energy being stored in the energy storage unit is received from one or more other consist members and the amount of electrical energy stored in the energy storage unit is greater than the amount of electrical energy removed from the energy storage unit. In this mode, electrical energy is not being provided by the locomotive to another consist member;

25 (iv) in a fourth operational mode, storing electrical energy in the locomotive's energy storage unit. In this fourth operational mode, most of the electrical energy being stored in the energy storage unit is received from the locomotive's generator and/or regenerative braking of the locomotive's plurality of traction motors. The amount of electrical energy stored in the locomotive's electrical storage unit is greater than the amount

30

of electrical energy removed from the locomotive's energy storage unit, and electrical energy is not being provided by the locomotive to another consist member;

(v) in a fifth operational mode, the locomotive dissipates electrical energy through its dynamic braking grid. In this fifth operational mode, neither the generator nor energy storage unit powers the traction motors and the energy storage unit does not receive and store additional electrical energy. In this mode, electrical energy is not being provided by the locomotive to another consist member; and

(vi) in a sixth operational mode, providing energy from the locomotive's electrical storage unit and/or generator and/or regenerative braking system to one or more other consist members. In this sixth operational mode, the selected locomotive is removing more energy from the selected locomotive's energy storage unit than is being stored in the selected locomotive's energy storage unit. As will be appreciated, where the consist includes a number of hybrid locomotives, the different locomotives can be simultaneously in a number of different operational modes.

The first operational mode is preferably selected when the amount of electrical energy internally available from a selected hybrid locomotive does not meet or exceed the amount of electrical energy currently being and/or prospectively to be consumed by the locomotive but excess energy (e.g., from a storage unit, a generator, a motor, and/or a regenerative braking system) is available from another consist member. In other words, the mode may be invoked when a state of charge in the electrical storage unit of the locomotive is less than a first selected threshold (e.g., meaning that the unit has insufficient stored energy for current and/or future operations), a charge in the electrical storage unit of one or more other consist members is greater than a second selected threshold (e.g., meaning that the other member(s) has/have energy available to share because it has adequate energy available for current and/or future operations), and an amount of electrical energy being provided to the locomotive's traction motors exceeds an amount of electrical energy output by the selected locomotive's generator.

The second operational mode is preferably selected when the amount of electrical energy internally available from the selected hybrid locomotive (e.g., from a storage unit, a generator, a motor, and/or a regenerative braking system) meets or exceeds the amount of electrical energy currently being and/or prospectively to be consumed by the locomotive. In

other words, the mode may be selected when a state-of-charge in the electrical storage unit of the locomotive is greater than a first selected threshold (e.g., meaning that the unit has sufficient stored energy for current and/or future operations) and the electrical energy required by the locomotive's traction motors is less than a selected electrical energy threshold (e.g., meaning that the locomotive has adequate available energy from internal source(s) to meet its current energy needs). The first selected threshold is related to an available amount of electrical energy from the locomotive's energy storage unit and generator.

The third operational mode is preferably selected when the selected hybrid locomotive's energy storage unit has insufficient state-of-charge based on current and/or anticipated future energy demands but excess energy is available from another consist member. In other words, the mode may be selected when a state-of-charge in the electrical storage unit of the locomotive is less than a first selected threshold (e.g., meaning that the energy storage unit has less than a minimum level of stored charge deemed necessary for normal operations of the hybrid locomotive) and a state-of-charge in the electrical storage unit of one or more other consist members is greater than a second selected threshold (e.g., meaning that the other consist member has adequate energy available for its own current and/or future operations and can provide energy to the hybrid locomotive).

The fourth operational mode is preferably selected when the selected hybrid locomotive's energy storage unit has insufficient state-of-charge based on current and/or anticipated energy demands but sufficient energy is available from one or more sources internal to the hybrid locomotive. Insufficient state-of-charge is typically found to exist when a state-of-charge in the electrical storage unit of the locomotive is less than a selected threshold (e.g., meaning that the storage unit has less than a minimum level of stored charge deemed necessary for normal operations).

The fifth operational mode is preferably selected when the selected hybrid locomotive's energy storage unit is fully charged and no other consist member requires the energy for its current and/or future operational needs. A fully charged state is typically found to exist when a state-of-charge in the electrical storage unit of the locomotive is greater than a selected threshold (e.g., meaning that the storage unit is fully charged).

The sixth operational mode is preferably selected when the selected hybrid locomotive has adequate available electrical energy for its current and/or prospective

operations but another consist member requires energy to meet its current and/or prospective demands. In other words, the mode may be selected when a state-of-charge in the electrical storage unit of another consist member is less than a first selected threshold (e.g., meaning that the unit in the other members needs energy from an external source), a state-of-charge in the electrical storage unit of the selected hybrid locomotive is greater than a second selected threshold (e.g., meaning that the unit is sufficiently charged for current and/or prospective operations of the hybrid locomotive), and an amount of electrical energy being provided to the other consist member's traction motors exceeds an amount of electrical energy output by the internal sources of the consist member.

10 The above-described embodiments and configurations are neither complete nor exhaustive. As will be appreciated, other embodiments of the invention are possible utilizing, alone or in combination, one or more of the features set forth above or described in detail below.

As used herein, "at least one . . . and", "at least one . . . or", "one or more of . . . and", "one or more of . . . or", and "and/or" are open-ended expressions that are both conjunctive and disjunctive in operation. For example, each of the expressions "at least one of A, B and C", "at least one of A, B, or C", "one or more of A, B, and C", "one or more of A, B, or C" and "A, B, and/or C" means A alone, B alone, C alone, A and B together, A and C together, B and C together, and A, B and C together.

20

BRIEF DESCRIPTION OF THE DRAWINGS

Figure 1 is a schematic side view of a basic cabless hybrid locomotive according to an embodiment of the present invention.

25 Figure 2 is a schematic side view of an alternate cabless hybrid locomotive configuration according to an embodiment of the present invention.

Figure 3 is a schematic side view of two cabless hybrid locomotives as part of a locomotive consist according to an embodiment of the present invention.

Figure 4 is a schematic side view of a cabless hybrid locomotive operating as an independent locomotive according to an embodiment of the present invention.

30 Figure 5 is a schematic side view of a cabless hybrid locomotive connected to an external power grid according to an embodiment of the present invention.

Figure 6 is a schematic side view of several cableless hybrid locomotives connected to an external power grid according to an embodiment of the present invention.

Figure 7 illustrates a preferred embodiment of the cableless hybrid locomotive power supply in more detail according to an embodiment of the present invention.

5 Figure 8 shows a logic flow diagram of the various locomotive configurations according to an embodiment of the present invention.

Figure 9 shows a logic flow diagram of a slug configuration according to an embodiment of the present invention.

10 Figure 10 shows a logic flow diagram of an energy storage configuration according to an embodiment of the present invention.

Figure 11 shows a logic flow diagram of a B-locomotive configuration according to an embodiment of the present invention.

Figure 12 shows a logic flow diagram of an independently operable locomotive configuration according to an embodiment of the present invention.

15 Figure 13 shows a logic flow diagram of a remotely controllable locomotive configuration according to an embodiment of the present invention.

Figure 14 shows a logic flow diagram of a power grid connection configuration according to an embodiment of the present invention.

20 Figure 15 is a logic flow diagram for determining energy allocation in a consist.

DETAILED DESCRIPTION

Figure 1 is a schematic side view of the basic cableless hybrid locomotive of the present invention. The locomotive 700 does not have a control cab and is referred to as a cableless hybrid locomotive. Prime power is provided by a generator 701 such as for example one or
25 more diesel engines, micro turbines, Stirling engines or fuel cells. The generator 701 is used to charge an energy storage unit 703 through a power conversion unit 702. The power conversion unit 702 may be an alternator/rectifier for example. The energy storage unit 703 may be, for example, a battery pack, a bank of capacitors, a compressed air storage system, a flywheel, or a combination of these. The wheels 705 of the locomotive 700 are driven by
30 traction motors 706 which are powered by the electrical output of the energy storage unit 703 or the generator 701 or both. The power conversion apparatus 702 that converts mechanical

energy from the prime energy source to direct current (DC) electrical energy is preferably an alternator/rectifier combination which outputs rectified DC power suitable for charging an energy storage unit and/or driving DC traction motors through one or more chopper circuits. Alternately, the power conversion apparatus 702 is an alternator/rectifier combination which outputs rectified DC power suitable for charging an energy storage unit and/or driving AC traction motors through one or more inverters. The generator 701 is large enough to provide a significant portion of the output power of the locomotive 700 and therefore requires a relatively large fuel tank 704. The fuel tank 704 can be located inside the locomotive or carried underneath as a belly tank or can be both. The power rating of the generator 701 is preferably in the range of 100 to 2,500 kW. The storage capacity of the energy storage unit 703 is preferably in the range of 500 to 2,500 kW-hrs. The capacity of the fuel tank 704 is preferably in the range of 500 to 6,000 gallons. This is the one configuration of the present invention. This locomotive configuration 700 may be controlled from a separate lead locomotive when used as part of a larger locomotive consist. It may also be used as a remotely controlled, independent locomotive as discussed later.

One of the energy storage unit options mentioned above is a compressed air storage system. In this system, electrical energy is used to compress air which is stored in cylinders at pressures typically up to a few thousand psi. When needed, this energy can be reconverted to electrical energy using one or more air motors and associated power conversion apparatus. The compressed air can also be used for other applications on the locomotive or train for example as a supply of compressed air for the brake system or for use in blowers used to provide cooling for traction motors.

Figure 2 is a schematic side view of an alternate cableless hybrid locomotive configuration of the present invention. As with the cableless hybrid configuration shown in Figure 1, prime power is provided by a generator 801. The generator 801 is used to charge an energy storage unit 803 through a power conversion unit 802. The wheels 807 of the locomotive 800 are driven by traction motors 806 which are powered by the electrical output of the energy storage unit 803 or the generator 801 or both by means of a common bus (not shown) connected to one or more chopper circuits or inverter circuits (also not shown). Fuel for the generator 801 is obtained from a large fuel tank 804. This embodiment includes a dynamic and regenerative braking system. During braking, the traction motors 806 of the

locomotive 800 can be switched to function as electrical generators to convert kinetic energy of braking to electric energy which is then stored, using a regeneration system, in the energy storage unit 803. Any excess energy that cannot be stored is dissipated by resistance grids 805. In this embodiment, energy is delivered to the energy storage unit 803 either from the generator 801 or from the regenerative braking system. Power is delivered to the traction motors 806 from the energy storage unit 803 or the generator 801 or both. The power rating of the generator 801 is preferably in the range of 100 to 2,500 kW. The storage capacity of the energy storage unit 803 is preferably in the range of 500 to 2,500 kW-hrs. The capacity of the fuel tank 804 is preferably in the range of 500 to 6,000 gallons. Energy can be delivered to the energy storage unit 803 from other sources. These include for example external sources such as a power grid or a stationary power generator. These stationary external sources require the cabless hybrid locomotive 800 to be stopped such as at a station or in a yard. Other external sources of energy include a third rail or an overhead catenary or from other locomotives when the locomotive 800 is used in a locomotive consist. As with the basic configuration shown in Figure 1, the locomotive configuration 800 may be controlled from a separate lead locomotive when used as part of a larger locomotive consist. It may also be used as a remotely controlled, independent locomotive as discussed later.

Figure 3 is a schematic side view of two cabless hybrid locomotives 902 and 903 as part of a locomotive consist 900. A locomotive consist 900 may be comprised of two or more locomotive types, including at least one locomotive 901 which is fully independent, one or more B-units, one or more slugs, one or more support tenders and/or one or more cabless hybrids. As an example, the consist 900 shown in Figure 3 is comprised of a conventional diesel locomotive 901 and two cabless hybrid locomotives 902 and 903 such as described in Figures 1 or 2. The cabless hybrids 902 and 903 are electrically coupled to the locomotive 901 for control signals. The cabless hybrids 902 and 903 may or may not be electrically coupled to the locomotive 901 for power exchange. If coupled to the locomotive 901 for power exchange, the energy from a dynamic braking system on locomotive 901 can be transferred to the energy storage units in one or both of the cabless hybrid locomotives 902 and 903. In the event of excess energy from the dynamic braking systems, the energy can be diverted to the resistive dissipation grids on any of the locomotives 901, 902 and/or 903. The cabless hybrids 902 and 903 can also be configured so that fuel stored on the cabless hybrids

902 and 903 can be delivered to the conventional locomotive 901. In general, a cabless hybrid can simultaneously serve as a fully functional B-unit and as supply tender for the other locomotives in the consist.

5 The cabless hybrid locomotive is a substantial improvement over the art as represented for example by the energy storage tender car disclosed in US 6,615,118 because the cabless hybrid can operate as a fully independent locomotive under various remote control scenarios. This innovation is shown schematically in Figure 4 which shows a schematic side view of a cabless hybrid locomotive 1000 operating as an independent locomotive pushing or pulling two other railcars 1002 and 1003. Railcars 1002 and 1003
10 may be freight cars or tankers or other railcars that cannot be moved on their own. The cabless hybrid locomotive 1000 can be operated remotely by an operator who is located on the locomotive 1000 or on any of the cars 1002 or 1003 that form the train. The operator can also be located externally, separated from the cabless hybrid locomotive 1000 and any of the cars 1002 and 1003 that form the train. In this latter case, the cabless hybrid locomotive 1000
15 can be independently operable by an operator: on foot; in a vehicle not connected to the train being pulled by the cabless hybrid locomotive; or in a building or in any other remote location in communication with the locomotive 1000. In this case the operator would control the cabless hybrid locomotive of the present invention by any number of remote control techniques, such as for example, a belt controller unit worn by the operator, a radio telemetry
20 unit, a wireless unit such as a computer or cellular phone, an optical link or any other commonly known means of communication. The operator may also have a video linkage to the locomotive 1000 such as for example by cameras located on the locomotive 1000 or any of the cars 1002 and/or 1003. The cameras which are located on the train 1000 would be in communication with the remote location where the operator is situated.

25 In another embodiment, the cabless hybrid locomotive can be operated in fully automated mode under the partial or full direction of a computer program. Such operation is preferred in operations that are repetitive and/or in dangerous areas such as radioactive mining or waste storage. One advantage of a cabless hybrid locomotive for such operations is that it may be necessary from time to time to operate on battery power only or from a third
30 rail or from an overhead catenary. In any of these modes, the prime power source would be turned off to eliminate any emissions.

The cabless hybrid locomotive is also a substantial improvement over the current art because the cabless hybrid can operate as a fully independent power supply under various remote control or automated scenarios to any facility that is accessible by rail. Figure 5 is a schematic side view of a cabless hybrid locomotive 1200 connected to an external power grid 1204 showing the principal components of the system and the location of the principal power switching gear that converts the locomotive 1200 from an independent rail locomotive mode to a power supply mode. In this example, the external power grid 1204 is not charging an energy storage unit 1202 but is rather being supplied by the locomotive power system which is comprised of both the energy storage source 1202 and a generator 1221. A power conditioning transformer 1107 is shown on top of the cabless locomotive 1100. This transformer 1203 matches the electrical output of the locomotive power system to the power grid 1204. The generator 1221, which supplies power to the power conversion apparatus 1201 for distribution is being operated from fuel supply stored in a fuel tank 1222. In this example, the cabless hybrid locomotive 1200 is stationary and traction motors 1223 and braking system, including the dissipating resistance grid 1224, are not being used. When acting as an independent power supply to a power grid, the traction motors 1223 are disconnected from the energy storage unit 1202 and from the generator 1221 by the switch 1206. The dynamic braking resistance grid system 1224 is disconnected from the energy storage unit 1202 by switch 1205. The locomotive power system is then connected to the power conditioning transformer 1203 and hence to the power grid 1204 by opening a switch 1208. It should be understood and appreciated that a hybrid locomotive with an operator's cab such as described in US 6,308,639 can be modified to function as an independent power supply to a power grid in the same manner as described above. It can also be appreciated that the cabless hybrid locomotive can function as an independent power supply to a third rail or an overhead catenary, for example in an emergency when grid power is interrupted to the third rail or catenary.

An aspect of the cabless hybrid locomotive operated as an independent power supply is that, with the presence of an energy storage unit such as for example a battery pack or bank of capacitors, power transients originating in the power grid can be absorbed more readily than by a generator such as a diesel engine acting alone. Also with the presence of an energy

storage unit such as for example a battery pack or bank of capacitors, the power flow to the power grid can be better regulated to provide a stable output voltage.

Figure 6 is a schematic side view showing how several cableless hybrid locomotives 1301 and 1302 might be connected to an external power grid 1304. Although only two locomotives are shown, others may be connected to the consist at location 1303. Each locomotive may be electrically coupled to the other locomotives for control signals. The power output from each locomotive may be connected separately to the power grid 1304 as shown in Figure 6. Alternately, the power output from each locomotive can be routed to a single locomotive feeding the grid (not shown).

Figure 7 illustrates a preferred embodiment of the cableless hybrid locomotive power supply in more detail. The equipment which typically comprises the locomotive is contained within the outline 1401. Prime power is provided by a generator 1404 such as for example a diesel engine, a microturbine, or a fuel cell. The generator 1404 is used to charge and maintain the charge in an energy storage unit 1406 through a power conversion unit 1405. The power conversion unit 1405 may be an alternator/rectifier for example. The energy storage unit 1406 may be, for example, a battery pack, a bank of capacitors, a compressed air storage system, or a flywheel, or a combination of these. The energy storage unit 1406 and power conversion unit 1405 are connected at a common bus represented by the junction 1409. The bus 1409 feeds DC power to one or more chopper circuits 1407 which drive DC traction motors 1408. As shown in Figure 7, there is a chopper circuit 1407 associated with each DC traction motor 1408. An alternate less preferred configuration is a single chopper circuit driving all the DC traction motors. In another embodiment, the bus 1409 feeds AC power to one or more inverters 1407 which drive AC traction motors 1408. As shown in Figure 7, there is an inverter 1407 associated with each AC traction motor 1408. An alternate less preferred configuration is a single inverter driving all the AC traction motors. If the locomotive power system is used to supply power to an external power grid 1402, then the bus junction 1409 feeds a power conditioning unit 1403 that matches the electrical output of the locomotive power system to the power grid 1402. The power conditioning unit 1403 may be a part of the cableless hybrid locomotive or it may be added when the cableless hybrid locomotive is parked at or near the external power grid 1402.

In the configuration where one or more inverters are used in conjunction with AC traction motors, it is also possible to utilize the inverter or inverters as the power conditioning apparatus to interface directly with the external power grid. In this configuration, a separate power conditioning transformer may not be required.

5

Selectable Hybrid Locomotive Configurations

Figure 8 shows a logic flow diagram of the various configurations of the locomotive of the present invention. In one configuration, the traction motors are not used (Power Source for External Grid) and in four configurations, the traction motors are used (Slug, Energy Storage, B-Locomotive, Independent Locomotive). In the Energy Storage configuration, the traction motors may be used for motoring and braking, or only for braking. The locomotive described in Figure 8 is comprised of one or more prime movers (engines such as diesels or gas turbines for example); an energy conversion system to convert engine power to electrical energy (alternator/rectifier for example); an energy storage system (battery pack, capacitor bank, or both, for example); a dynamic braking system wherein the energy can be dissipated in a resistance grid or recaptured by the energy storage system through a regenerative braking system; a power conditioning system (such as an inverter and transformer combination for conversion to AC or buck/boost system for conversion to DC) for power flow to and from an external power source (for example, an electrical power distribution grid, a catenary or a third rail); one or more traction motors (AC or DC induction motors for example); various sensors that monitor current, voltage and rotational speeds (RPMs) on various components; and a controller (PLC, industrial computer or the like). The locomotive operator selects the desired configuration 2001 and the controller then automatically applies the proper control algorithms to implement locomotive operation for that configuration. Other than selecting locomotive configuration, the process of control is essentially automated. The configurations or operating modes are:

- operation as a slug 2002 where the traction motor power is supplied by a mother locomotive and most of the ballast of the slug is provided by the weight of the engines and energy storage apparatuses of the locomotive of the present invention. This mode is useful when a consist requires additional

30

tractive surface such as provided by the traction motors on the slug, for example operations on a level wet track.

5 □ operation as an energy storage unit 2003 where the energy storage unit receives energy from: a regenerative braking system on the locomotive of the present invention or other members of the consist; or from the engine or engines on the locomotive of the present invention; or excess generated energy (such during idling or descending grades for example) by the prime movers of other members of the consist. The stored energy may then be distributed back to other members of the consist to provide additional power when needed (for example ascending grades or accelerating) or to rearrange stored and recaptured energy within the members of the consist. This mode is useful for operations where there is a number of stops and starts such as for example use in a commuter or road switcher consist and /or where a number of grades must be ascended and descended.

10 □ operation as a B-locomotive 2004 in a consist where the locomotive of the present invention is controlled by an A-locomotive which synchronizes the acceleration and braking of all other B-locomotives including the locomotive of the present invention. In this configuration, the locomotive of the present invention provides its own propulsive power (a combination of engines and energy storage), it own braking (air brakes and dynamic braking with regenerative braking when possible). In this configuration, the internal power management of the locomotive of the present invention is self-contained. Typically, the locomotive of the present invention receives commands from an A-locomotive either by wireless or other remote communication means, or physically connected communication lines between cars of the train. This mode is useful when a B-locomotive is required where the B-locomotive is emissions friendly and fuel efficient but the A-locomotive has no provisions for managing a hybrid locomotive.

15 □ operation as an independent locomotive 2005 which may be controlled from a cab on the locomotive 2007 of the present invention or remotely 2006 by any number of means such as radio control. In this configuration, the

20

25

30

locomotive provides its own propulsive power (a combination of engines and energy storage), its own braking (air brakes and dynamic braking with regenerative braking when possible) but is controlled by an operator. In this configuration, the internal power management of the locomotive is self-contained. If operated as an independent locomotive, the cab may be a temporary cab or a permanent cab that is locked while in other cabled configurations. This mode is useful when a single industrial, yard switcher, road switcher or commuter hybrid locomotive is required. The industrial and yard hybrid locomotives may preferably be remote controlled.

5

10

- operation as a power source for an external power grid, catenary or third rail. In this configuration, the traction motors and braking systems are turned off and the locomotive remains stationary while supplying, receiving or regulating power. In this configuration, the locomotive utilizes its prime power and energy storage apparatuses to supply, regulate or receive power from an external source. The power on the DC bus of the locomotive is converted to AC or DC as needed by power conditioning apparatuses. The control algorithm is responsive to the requirements of the external grid, supplying power if needed, regulating power quality (such as ripple) or receiving power if the grid has an excess. This configuration is useful for a rescue locomotive to provide emergency power to a third rail or catenary so that other trains can be moved to operable sections of the line; or as a temporary or long term power source for a power grid that requires additional power and/or power regulation.

15

20

The unifying theme is the locomotive's controller and DC bus which, under the direction of the controller, allocates power within the locomotive and to adjacent locomotives or external power grids.

25

Slug Configuration

Figure 9 shows a logic flow diagram of a slug configuration for the locomotive of the present invention. This configuration is desirable when a locomotive consists of more than enough propulsive power but not enough tractive surface to avoid wheel slip or skid

30

such as might be the case, for example, for accelerating or ascending a grade in wet or icy conditions; or braking or descending a grade in similarly adverse conditions. In this configuration, the controller on locomotive of the present invention turns off its engines 2106 and energy storage system 2107 (whilst continuing to ensure that the energy storage system current and/or voltage is monitored to maintain a desired state-of-charge of the energy storage system) and disables the external power grid connections 2109. The controller of the locomotive of the present invention allows the flow of DC power from a mother or mother locomotives to its traction motors 2108 which can be used to provide propulsive power to the traction motors or divert braking energy from the traction motors in braking mode to its dynamic braking dissipating grid 2103. Otherwise the controller turns off the regenerative braking system 2105 and if not needed the dynamic braking system 2104.

The controller monitors power, braking, idling, stop and start requests from the mother locomotive. In this configuration, the controller measures DC bus voltage and current to determine power flow into the locomotive of the present invention. The controller also monitors individual traction motor currents to ensure that the motor current limit is not exceeded and to ensure that the total energy throughput in the motor windings is within motor limits. Traction motor current is also used, along with motor RPMs, to determine tractive effort. Traction motor RPMs may also be monitored to determine if wheel slip or skid occur. The controller also monitors current and total energy throughput for the resistive braking grids to ensure that their dissipating capacity is not exceeded. Measurement of DC bus voltage allows current measurements to be used to compute total energy throughput. A consistency check may be performed using the known motor resistance and braking grid resistances.

Energy Storage Configuration

Figure 10 shows a logic flow diagram of an energy storage configuration 2201 for the locomotive of the present invention. This configuration is desirable when the consist can take advantage of excess energy generated either by any of the members of the consist or from regenerative braking within the consist, where the energy storage configuration of the present invention is member of the consist. In this configuration, the controller on locomotive of the present invention determines whether excess energy is routed via its DC bus to its energy

storage system 2211 or to other members of the consist via a DC bus 2202 connecting the other operating members of the consist or to its dynamic braking dissipating grid 2203. This latter option would be invoked when the energy storage capacity is full and can accept no further "free" energy. The controller may also turn on the engines 2207 to charge the energy storage system 2209 when needed or to provide additional power for propulsion 2210. The controller may turn off the engines 2208 and dynamic braking system 2204 when not needed. In this energy storage configuration, it is possible that from time to time, the controller on locomotive of the present invention would use energy stored in its energy storage system to provide propulsive power via its own traction motors 2215 or to redirect power to the other locomotives in the consist for an extra power boost when conditions dictate. For example, if the energy storage system is near or at storage capacity, the stored energy may be used for ascending grades in anticipation of descending the grade wherein additional "free" energy may be recouped. In this configuration, the controller of locomotive of the present invention disables the external power grid connections 2217. When the energy storage system is on 2211, it may be directed by the controller to provide energy for propulsion 2212 (its own propulsion 22121 or for propulsion to other members of the consist 22122); to absorb energy from regenerative braking 2213 (its own regenerative braking 22131 or from the regenerative braking of other members of the consist 22132); and to absorb excess energy from the engines 2214 (its own engine(s) 22141 or from the engines of other members of the consist 22142).

The controller monitors power, braking, idling, stop and start requests from the mother locomotive. In addition to the measurements described for the slug configuration, the engine alternator/rectifier output current is measured to determine engine output power. The engine output is controlled by its applied excitation current which is itself determined by the controller depending on power and braking requests as well as the state-of-charge of the energy storage system. Engine RPMs may also be monitored. With the energy storage unit on, current (in the case of a battery pack or capacitor bank) to the energy storage unit is monitored to maintain an accounting of the state-of-charge of the energy storage system (by integrating the current as a function of time). The voltage across the energy storage system may also be measured. The controller ensures that charging and discharging currents are maintained below predetermined levels; that charging voltage is maintained below a

predetermined level; and that discharge voltage is maintained above another predetermined level. Since regenerative braking may be used, the current and RPMs of the traction motors are monitored to again ensure current limits and energy throughput capacities are not exceeded in both motoring and dynamic braking conditions. The above measurements are sufficient to account for power inflow and outflow to the engines, motors, energy storage, dynamic braking grids and to and from other members of the consist. In this configuration, power, braking, idling, stop and start requests originate from other members of the consist. The main power, braking, idling, stop and start requests typically come from the lead or A-locomotive. Energy storage transfer commands may come from other members of the consist depending on their own energy storage and power requirements.

B-Locomotive Configuration

Figure 11 shows a logic flow diagram of a B-locomotive configuration 2301 for the locomotive of the present invention. This configuration is desirable when the consist requires propulsive power and tractive effort 2316 from the locomotive(s) of the present invention and other B-locomotives in the consist via a communication line 2302 connecting the other operating members of the consist. The communication line may be a physical connection or a wireless connection. In this configuration, the controller on locomotive of the present invention responds to the power and braking commands from the A-locomotive of the consist. Otherwise the controller manages the internal allocation of power between its engines 2307 through 2310 and energy storage system 2311 through 2315 as well as operating its internal dynamic and/or regenerative braking system 2303 through 2306. In this configuration, the controller also disables the external power grid connections 2317.

The controller monitors the power, braking, idling, stop and start requests and utilizes measurements described in the slug and energy storage configurations to control the engines, energy storage, motor and braking systems to comply with the power, idling or braking requests from the A-locomotive.

Independently Operable Locomotive Configuration

Figure 12 shows a logic flow diagram of an independently operable configuration 2401 for the locomotive of the present invention. This configuration is desirable when a

locomotive is required for yard or road switching operations as well as industrial applications. In this mode, the controller is responsive to the controls in the cab 2402 for all power, braking, idling, stop and start commands requested by the locomotive's engineer. The controller automatically manages the internal allocation of power between its engines 2407 through 2410 and energy storage system 2411 through 2415 as well as operating its internal dynamic and/or regenerative braking system 2403 through 2406. In this configuration, the controller again disables the external power grid connections 2418 except when necessary to connect into an external grid 2419 such as a catenary 2420, a third rail 2421 or external power grid 2422 for recharging or emergency power supply. In this configuration, the locomotive may be operated as a normal locomotive by utilizing a temporary operating cab or, if a cab is present and locked (rendering it a cabless locomotive), the cab may be unlocked. One or more locomotives may be operated in a consist for switching purposes with one of the locomotives of the present invention functioning as an A-locomotives and the others as slugs, energy storage units or B-locomotives.

In this configuration, all the measurements and thresholds described for the slug, energy storage and B-locomotive configurations continue to be monitored. Power, braking, idling, stop and start requests now come from an on-board engineer. The measurements are sufficient to account for power inflow and outflow to the engines, motors, energy storage and dynamic braking grids. In this configuration there is typically no power transfer to and from other members of the consist.

Remotely Controllable Locomotive Configuration

Figure 13 shows a logic flow diagram of a remotely controllable configuration 2501 for the locomotive of the present invention. The locomotive may be operated in remote mode as discussed for example in Figure 4 using a temporary cab on the locomotive or a wireless connection 2502 operated from another location. This configuration is desirable when a hybrid locomotive is required for yard or industrial operations. In this mode, the controller is responsive to the remote operator 2502 for all power to the traction motors 2516 and braking commands much as discussed in the previous figure. The controller automatically manages the internal allocation of power between its engines 2507 through 2510 and energy storage system 2511 through 2515 as well as operating its internal dynamic and/or

regenerative braking system 2503 through 2506. In this configuration, the controller disables the external power grid connections 2517.

In this configuration, all the measurements and thresholds described for the independently operable locomotive configuration are made. Power, braking, idling, stop and start requests now come from an engineer/operator working at a remote control console.

Independent Power Source Configuration

Figure 14 shows a logic flow diagram of a power grid connection configuration 2601 for the locomotive of the present invention. In this mode, the controller automatically disables the traction motors 2613 and braking systems 2603 and 2604 and operates the engine/energy storage system as an independent power source. The engine(s) 2605 may be operative to provide power to a grid 2608 or to charge the energy storage system 2607. The energy storage system 2609 may be operated as determined by the controller to provide surge capacity 2610 for the external grid, power 2612 for the external grid or may absorb excess power 2611 from the grid. The controller also enables the appropriate power conditioning equipment 2614 to connect with the external power grid. As noted previously, the hybrid locomotive configured as a power supply can be used to supply an external grid; or can be used to provide power to a catenary or third rail if they lose power and thereby enable other trains to proceed safely to a powered portion of the electrified system. The power source can be used to supply power to a main electrical power grid to:

- provide all the required power 2616
- supplement generation capacity for the utility to meet demands during periods of high electrical usage 2616
- supplement and improve the quality of power received from the local utility 2617
- correct on-going power quality issues, in addition to providing a reserve of energy for uninterrupted power supply, peak shaving and load leveling 2617

In this mode, the engine or engines of the locomotive provide the primary power to maintain the energy level of the energy storage system. The controller maintains the required power on the locomotive's DC bus. In the case of providing service to a DC grid, the power conditioning apparatus might consist of buck or boost circuits to adjust the locomotive's DC

bus voltage to the required DC grid voltage. In the case of providing service to a AC grid , the power conditioning apparatus might consist of an inverter and transformer combination to adjust the locomotive's DC bus voltage to the required AC grid voltage. In both cases, power can flow to or from the locomotive depending on grid demand conditions. Also, both
 5 AC and DC power conditioning systems can provide voltage regulation when the external grid is experiencing quality problems. As can be appreciated, several locomotives of the present invention can be connected together to provide the required level of power. Each controller can manage its own power from its engines(s) and energy storage units. The locomotives can be connected to the external grid individually or via a common DC bus to
 10 a single power conditioning apparatus. In the latter case, the power conditioning apparatus could be located in a separate rail car.

The measurements and thresholds applicable to this configuration include all those described in the energy storage configuration (except those appropriate to the traction motors and braking resistance grids, which are turned off) . In addition, the voltage and current to
 15 the external source is measured. The controller on the locomotive of the present invention must also ensure that the current and voltage limits of the power conditioning apparatuses (inverter/transformer for AC, buck/boost for DC) are not exceeded. The controller must also respond to power quality requirements when providing power or quality control to the external circuit. The fuel supply for the engines in the locomotive or locomotives providing
 20 power must be monitored and replenished from time to time. In this configuration, monitoring the various measurements and component statuses can be made on-site or from a remote location.

The following table illustrates representative maximum power, current and voltages for selected systems on a typical hybrid locomotive configuration.

25

| Typical Parameters for a 2,500 HP Hybrid Locomotive | | | | | | |
|---|--------|----------------|--------------------|---------------------|--------------------------|------------------|
| Component | Number | Max Power (kW) | Max Current (amps) | Max Voltage (volts) | Storage Capacity (A-hrs) | Max Speed (rpms) |
| Diesel Engines with Alternator/Rectifier | 1 | 750 | 700 | 1,200 | | 1,800 |
| 30 Traction Motors (Motoring or Braking) | 6 | 350 | 1,800 | 1,200 | | 1,200 |
| Batteries in Series Battery Pack | 350 | 1,100 | 1,800 | 800 | 525,000 | |
| 35 Dynamic Brake Resistance Grid | 1 | 2,000 | 1,800 | 1,200 | | |
| DC Bus | 1 | 2,500 | 2,500 | 1,200 | | |

Figure 15 is a logic flow diagram for determining energy allocation amongst members of a consist. A member of a locomotive consist can be a conventional locomotive, a hybrid locomotive, a slug or an energy storage tender car. For any hybrid locomotive that is a member of a consist, there are at least six operational modes that involve the state of energy of and the allocation of energy by the hybrid consist member. In a first operational mode, the hybrid locomotive is motoring and is receiving most of its power from another member or members of the consist. In a second operational mode, the hybrid locomotive is motoring and is receiving most of its power from itself. In a third operational mode, the hybrid locomotive is storing more energy than it is using and is receiving most its storable energy from another member or members of the consist. In a fourth operational mode, the hybrid locomotive is storing more energy than it is using and is receiving most of its energy from itself. In a fifth operational mode, the hybrid locomotive is braking and is dissipating energy to its own resistive braking grids and not storing any energy. In this fifth mode, the energy from regenerative braking may be provided to other members of the consist if they have available storage capacity or immediate unmet energy requirements. In a sixth operational mode, the hybrid locomotive is providing energy to another member or members of the consist and is reducing its own amount of stored energy.

The operational mode of the hybrid locomotive is normally determined, at least in part, by the state-of-charge of its energy storage system. If the state-of-charge is below a first predetermined threshold, the energy storage unit typically requires charging energy from itself or another member or members of the consist, and typically cannot provide energy to other members of the consist. If the state-of-charge is above a second predetermined threshold, the energy storage unit typically cannot accept energy from other members of the consist and is available to provide energy to its own traction motors, or to other members of the consist.

Typical maximum and minimum preferred states of charge for the examples of lead-acid and nickle-zinc battery packs as well as energy storage capacitors suitable for hybrid locomotives are shown in the following table. The table also shows typical maximum preferred rates of charging and typical maximum preferred rates of discharging for these battery types as well as for energy storage capacitors.

| | Lead Acid Battery | Ni-Zinc Battery | Capacitor | Lead Acid Battery | Ni-Zinc Battery | Capacitor |
|----------------|-------------------------|-----------------|-----------|---------------------------|-----------------|-----------|
| | Maximum State-of-Charge | | | Maximum Rate-of-Charge | | |
| Most Preferred | 100% | 100% | 100% | 1,500 | 1,800 | 2,000 |
| More Preferred | 90% | 95% | | 750 | 1,500 | 1,750 |
| Preferred | 80% | 90% | | 300 | 1,200 | 1,500 |
| Preferred | 50% | 15% | | 1,800 | 1,600 | 1,600 |
| More Preferred | 20% | 10% | | 1,500 | 1,800 | 1,800 |
| Most Preferred | 10% | 0% | 0% | 1,200 | 2,000 | 2,000 |
| | Minimum State-of-Charge | | | Maximum Rate-of-Discharge | | |

Figure 15 illustrates an example of a menu that might be executed by an algorithm stored in a master controller for a consist containing hybrid members. The algorithm selects a consist member 3001 and then determines the current energy state of the selected consist member 3002. In the case of a battery pack or capacitor bank, the energy state may be characterized by the storage unit's current state-of-charge, current power consumption/production by the traction motors, and/or the rated capacity of the generator or engine. The algorithm may also evaluate the anticipated energy state of the selected consist member 3003. This could include, for example, the projected power and braking requirements for grades, curves, stops and starts that are associated with the track ahead as determined by a stored database and GPS system for example. The algorithm then decides if the selected consist member requires a change of its state of energy 3004 which could involve providing, receiving, using, storing or dissipating energy. Typically, where the current state requires a first state and the anticipated energy state a second state, the more energy conservative (or lower energy consumptive) state is invoked. For example, if the battery is current at or near zero charge but the hybrid locomotive is nearing the top of a hill after which regenerative braking and energy storage can occur, the energy state required to address immediately the low state of charge is preferred. If the answer is no, then the algorithm returns to the top of the menu 3001. If the answer is yes, then the algorithm decides if the selected consist member requires additional energy from another consist member or members 3005. If the answer is no, then the algorithm requests the selected hybrid locomotive to go to another energy state 3010 and then the algorithm returns to the top of the

menu 3001. If the answer is yes, then the algorithm reviews the energy states of the other consist members for available energy 3006. Then the algorithm determines if there is any available energy from any of the other consist members 3007. If the answer is no, then there is no energy available and the algorithm notifies the engineer of the energy problem and may additionally make a recommendation to the engineer 3009. That recommendation could be, for example, to reduce the power notch setting to some or all the members of the consist. If the answer to the availability of energy from any of the other consist members 3007 is yes, then the algorithm selects an available member or members of the consist and requests the selected member and the other selected consist members to enter into a new state of energy 3008. The algorithm then returns to the top of the menu 3001. When the engineer is notified 3009 of the situation and possibly with a recommendation, the engineer may manually change the power request and allow the algorithm to select an available member or members of the consist and requests the selected member and the other selected consist members to enter into a new state of energy 3008. The algorithm then returns to the top of the menu 3001.

15 A number of variations and modifications of the invention can be used. As will be appreciated, it would be possible to provide for some features of the invention without providing others.

For example in one alternative embodiment, the various inventive features are applied to vehicles other than locomotives, such as cars, railroad cars, and trucks. The control logic set forth above may be implemented as a logic circuit, software, or as a combination of the two.

20 The present invention, in various embodiments, includes components, methods, processes, systems and/or apparatus substantially as depicted and described herein, including various embodiments, subcombinations, and subsets thereof. Those of skill in the art will understand how to make and use the present invention after understanding the present disclosure. The present invention, in various embodiments, includes providing devices and processes in the absence of items not depicted and/or described herein or in various embodiments hereof, including in the absence of such items as may have been used in previous devices or processes, e.g., for improving performance, achieving ease and/or
30 reducing cost of implementation.

The foregoing discussion of the invention has been presented for purposes of illustration and description. The foregoing is not intended to limit the invention to the form or forms disclosed herein. In the foregoing Detailed Description for example, various features of the invention are grouped together in one or more embodiments for the purpose of streamlining the disclosure. This method of disclosure is not to be interpreted as reflecting an intention that the claimed invention requires more features than are expressly recited in each claim. Rather, as the following claims reflect, inventive aspects lie in less than all features of a single foregoing disclosed embodiment. Thus, the following claims are hereby incorporated into this Detailed Description, with each claim standing on its own as a separate preferred embodiment of the invention.

Moreover, though the description of the invention has included description of one or more embodiments and certain variations and modifications, other variations and modifications are within the scope of the invention, e.g., as may be within the skill and knowledge of those in the art, after understanding the present disclosure. It is intended to obtain rights which include alternative embodiments to the extent permitted, including alternate, interchangeable and/or equivalent structures, functions, ranges or steps to those claimed, whether or not such alternate, interchangeable and/or equivalent structures, functions, ranges or steps are disclosed herein, and without intending to publicly dedicate any patentable subject matter.

What is claimed is:

1. A method, comprising:

(a) providing a locomotive, the locomotive comprising a plurality of axles, each connected to a plurality of wheels, an energy storage unit for storing electrical energy, and
5 a generator for providing electrical energy to the energy storage unit;

(b) electrically connecting the locomotive to an external power distribution system, the external power distribution system providing electrical energy to at least one electrical device external to the locomotive; and

(c) at least one of the energy storage unit and generator providing electrical energy
10 to the external power distribution system.

2. The method of claim 1, wherein the locomotive further includes a plurality of traction motors connected to and driving the plurality of axles and a power conditioning unit for matching the electrical energy output by the at least one of the energy storage unit and generator to the power distribution system.

3. The method of claim 1, wherein the external power distribution system
15 comprises at least one of a catenary and a third rail for powering other locomotives.

4. The method of claim 1, wherein the energy storage unit provides electrical energy to the external power distribution system and wherein the external power distribution system is a power grid.

5. The method of claim 2, wherein, during the providing step (c), the at least one
20 of the energy storage unit and generator is in an switched state, wherein, in the switched state, the at least one of the energy storage unit and generator is disconnected from the plurality of traction motors and, in the unswitched state, the at least one of the energy storage unit and generator is connected to the plurality of traction motors.

6. The method of claim 5, wherein the locomotive further includes a dynamic
25 braking resistance grid system and wherein, in the switched state, the dynamic braking resistance grid system is disconnected from the energy storage unit and, in the unswitched state, the dynamic braking resistance grid system is connected to the energy storage unit.

7. The method of claim 1, wherein the energy storage unit is at least one of a
30 battery pack, a capacitor bank, a compressed air storage system, and a flywheel, wherein a

power rating of the generator ranges from about 100 to about 2,500 kW, and wherein the energy storage unit has a storage capacity ranging from about 500 to about 2,500 kW-hrs.

8. The method of claim 2, wherein the locomotive further includes a power conversion unit electrically connected to both the generator and energy storage unit, wherein
5 the power conversion unit is electrically connected to the energy storage unit by a bus, and wherein electrical energy is provided by the energy storage unit to the traction motors by the bus, and wherein at least one of a chopper circuit and inverter drives the traction motors.

9. The method of claim 2, wherein the power conditioning unit is an inverter and a transformer.

10 10. The method of claim 2, wherein the power conditioning unit is a buck/boost circuit.

11. A locomotive, comprising:

a plurality of axles, each connected to a plurality of wheels;

an energy storage unit for storing electrical energy;

15 a plurality of traction motors driving the plurality of axles; and

a generator for providing electrical energy to the energy storage unit, wherein, in a switched state, at least one of the energy storage unit and generator is disconnected from the plurality of traction motors and connected to an external power distribution system and, in an unswitched state, the at least one of the energy storage unit and generator is connected to
20 the plurality of traction motors and disconnected from the external power distribution system, whereby, when in the switched state the at least one of the energy storage unit and generator provides electrical energy to the external power distribution system.

12. The locomotive of claim 11, wherein the locomotive further includes a power conditioning unit for matching the electrical energy output by the at least one of the energy
25 storage unit and generator to the power distribution system.

13. The locomotive of claim 11, wherein the external power distribution system comprises at least one of a catenary and third rail for powering other locomotives.

14. The locomotive of claim 11, wherein the energy storage unit provides electrical energy to an external power grid.

30 15. The locomotive of claim 11, wherein the locomotive further includes a dynamic braking resistance grid system and wherein, in the switched state, the dynamic

braking resistance grid system is disconnected from the energy storage unit and, in the unswitched state, the dynamic braking resistance grid system is connected to the energy storage unit.

16. The locomotive of claim 11, wherein the energy storage unit is at least one of
5 a battery pack, a capacitor bank, a compressed air storage system, and a flywheel, wherein a power rating of the generator ranges from about 100 to about 2,500 kW, and wherein the energy storage unit has a storage capacity ranging from about 500 to about 2,500 kW-hrs.

17. The locomotive of claim 11, wherein the locomotive further includes a power
10 conversion unit electrically connected to both the generator and energy storage unit, wherein the power conversion unit is electrically connected to the energy storage unit by a bus, and wherein electrical energy is provided by the energy storage unit to the traction motors by the bus, and wherein at least one of a chopper circuit and inverter drives the traction motors.

18. The locomotive of claim 12, wherein, if the electrical energy provided to the
15 power distribution system is alternating current, the power conditioning unit is an inverter and transformer and, if the electrical energy provided to the power distribution system is direct current, the power conditioning unit is a buck/boost circuit.

19. In a consist comprising a plurality of members interconnected by a direct
20 current power bus for exchanging electrical energy, at least one of the members being a locomotive, the locomotive comprising a plurality of axles, each axle connected to a plurality of wheels, an energy storage unit for storing electrical energy, a generator for providing electrical energy to the energy storage unit, and a plurality of traction motors for receiving electrical energy from at least one of the energy storage unit and generator and driving the plurality of axles, a method comprising:

25 monitoring, for the locomotive, at least the voltage of and/or current to and/or from the energy storage unit, the output volts and/or current of the generator, and the current to and/or from and/or revolutions-per-minute of one or more of the traction motors; and

for the locomotive, using the results of the monitoring step to select from among at least one of the following discrete operational modes:

30 in a first operational mode, powering the plurality of traction motors of the locomotive using predominantly electrical energy from one or more other members of the consist, wherein, in the first operational mode, the locomotive stores more energy in the

energy storage unit than is being removed from the energy storage unit and electrical energy is not being provided by the locomotive to another consist member;

in a second operational mode, powering the plurality of traction motors of the locomotive using predominantly electrical energy from the locomotive's energy storage unit and/or generator, wherein, in the second operational mode, the amount of electrical energy stored in the locomotive's electrical storage unit is less than the amount of electrical energy removed from the locomotive's energy storage unit and electrical energy is not being provided by the locomotive to another consist member;

in a third operational mode, storing electrical energy in the locomotive's energy storage unit, wherein, in the third operational mode, at least most of the electrical energy being stored in the energy storage unit is received from one or more other consist members and the amount of electrical energy stored in the energy storage unit is greater than the amount of electrical energy removed from the energy storage unit and electrical energy is not being provided by the locomotive to another consist member;

in a fourth operational mode, storing electrical energy in the locomotive's energy storage unit, wherein, in the fourth operational mode, at least most of the electrical energy being stored in the energy storage unit is received from the locomotive's generator and/or regenerative braking of at least one of the locomotive's plurality of traction motors and the amount of electrical energy stored in the locomotive's electrical storage unit is greater than the amount of electrical energy removed from the locomotive's energy storage unit and electrical energy is not being provided by the locomotive to another consist member;

in a fifth operational mode, the locomotive dissipating electrical energy through dynamic braking, wherein, in the fifth operational mode, neither the generator nor energy storage unit powers the traction motors and wherein the energy storage unit does not receive and store additional electrical energy and electrical energy is not being provided by the locomotive to another consist member; and

in a sixth operational mode, providing energy from at least one of the locomotive's electrical storage unit, generator and traction motor in braking mode to one or more other consist members, wherein, in the sixth operational mode, the selected locomotive is removing more energy from the selected locomotive's energy storage unit than is being stored in the selected locomotive's energy storage unit.

20. The method of claim 19, wherein the consist comprises a plurality of locomotives and, during a selected time interval, a first locomotive in the consist is in the first operational mode and a second locomotive in the consist is in the sixth operational mode.

5 21. The method of claim 19, wherein the consist comprises a plurality of different locomotives and a plurality of the locomotives are, at a selected time, in a plurality of different ones of the operational modes.

10 22. The method of claim 21, wherein at least some of the locomotives are separated by haulage cars and wherein the common power bus is supported by the haulage cars.

15 23. The method of claim 19, wherein the first operational mode is selected when a charge in the electrical storage unit of the locomotive is less than a first selected threshold, a charge in the electrical storage unit of one or more other consist members is greater than a second selected threshold, and an amount of electrical energy being provided to the locomotive's plurality of traction motors exceeds an amount of electrical energy output by the generator.

20 24. The method of claim 19, wherein the second operational mode is selected when a charge in the electrical storage unit of the locomotive is greater than a selected threshold and the electrical energy required by the locomotive's plurality of traction motors is less than a selected electrical energy threshold, the selected energy threshold being related to an available amount of electrical energy from the locomotive's energy storage unit and generator.

25 25. The method of claim 19, wherein the third operational mode is selected when a charge in the electrical storage unit of the locomotive is less than a first selected threshold and a charge in the electrical storage unit of one or more other consist members is greater than a second selected threshold.

26. The method of claim 19, wherein the fourth operational mode is selected when a charge in the electrical storage unit of the locomotive is less than a selected threshold.

30 27. The method of claim 19, wherein the fifth operational mode is selected when a charge in the electrical storage unit of the locomotive is greater than a selected threshold.

28. The method of claim 19, wherein the sixth operational mode is selected when a charge in the electrical storage unit of the one or more other consist members is less than a first selected threshold, a charge in the electrical storage unit of locomotive is greater than a second selected threshold, and an amount of electrical energy being provided to the one or more other consist member's traction motors exceeds an amount of electrical energy output by the generator of the one or more other consist members.

29. The method of claim 19, wherein each of the plurality of consist members convert electrical energy from alternating current for powering traction motors to direct current for storage and transportation over the power bus and vice versa.

30. A method for operating a locomotive, comprising:

(a) providing at least a first locomotive, the first locomotive comprising a plurality of axles, each connected to a plurality of wheels, an energy storage unit for storing electrical energy, a generator for providing electrical energy to the energy storage unit, and a plurality of traction motors for receiving electrical energy from at least one of the energy storage unit and generator and driving the plurality of axles; and

(b) an operator selecting from among at least three of the following discrete operational modes:

(i) in a slug operating mode, the first locomotive is a member of a consist and the plurality of traction motors of the first locomotive are powered using predominantly electrical energy from another consist member, wherein, in the slug operating mode, more electrical energy is provided to the first locomotive's traction motors than is stored in the first locomotive's energy storage unit;

(ii) in an energy storage operating mode, the first locomotive is a member of the consist and electrical energy is stored in the energy storage unit, wherein, in the energy storage operating mode, at least a portion of the stored electrical energy is received by at least one of regenerative braking of the first locomotive and consist member, and more electrical energy is stored in the first locomotive's energy storage unit than is provided to the first locomotive's traction motors;

(iii) in a B-locomotive operating mode, the first locomotive is a member of the consist and electrical energy provided by the first locomotive's energy storage unit and/or generator is at least one of stored and consumed, wherein, in the B-locomotive operating

mode, the first locomotive is a member of the consist and the amount of electrical energy provided by the first locomotive's energy storage unit and/or generator is greater than an amount of electrical energy received from another locomotive;

5 (iv) in an independent operating mode, electrical energy provided by the first locomotive's energy storage unit and/or generator is at least one of stored and consumed, wherein, in the independent operating mode, the first locomotive is a not member of a consist; and

10 (v) in a power source operating mode, electrical energy is provided to an external power distribution system that supplies electrical energy to one or more electrical devices, wherein, in the power source operating mode, at least most of the electrical energy provided by the first locomotive's storage unit and/or generator is provided to the external power distribution system.

31. The method of claim 30, wherein the operator selects from among all of the operating modes (i)-(v).

15 32. The method of claim 30, wherein the operator selects the slug operating mode (i).

33. The method of claim 32, wherein the locomotive consist, in the absence of the operator selecting the slug operating mode (i), has insufficient tractive surface to avoid wheel slip and/or skid.

20 34. The method of claim 30, wherein the operator selects the energy storage mode (ii).

35. The method of claim 30, wherein the operator selects the B-locomotive operating mode (iii).

25 36. The method of claim 35, wherein, in the B-locomotive operating mode (iii), the first locomotive is under the control of an A-locomotive.

37. The method of claim 30, wherein the operator selects the independent operating mode (iv).

38. The method of claim 37, wherein the first locomotive is remote controlled by the operator.

30 39. The method of claim 30, wherein the operator selects the power source operating mode (v).

40. The method of claim 39, wherein the external power distribution system is at least one of a catenary and a third rail and the one or more electrical devices is another locomotive.

41. The method of claim 39, wherein the external power distribution system is a
5 power grid.

700

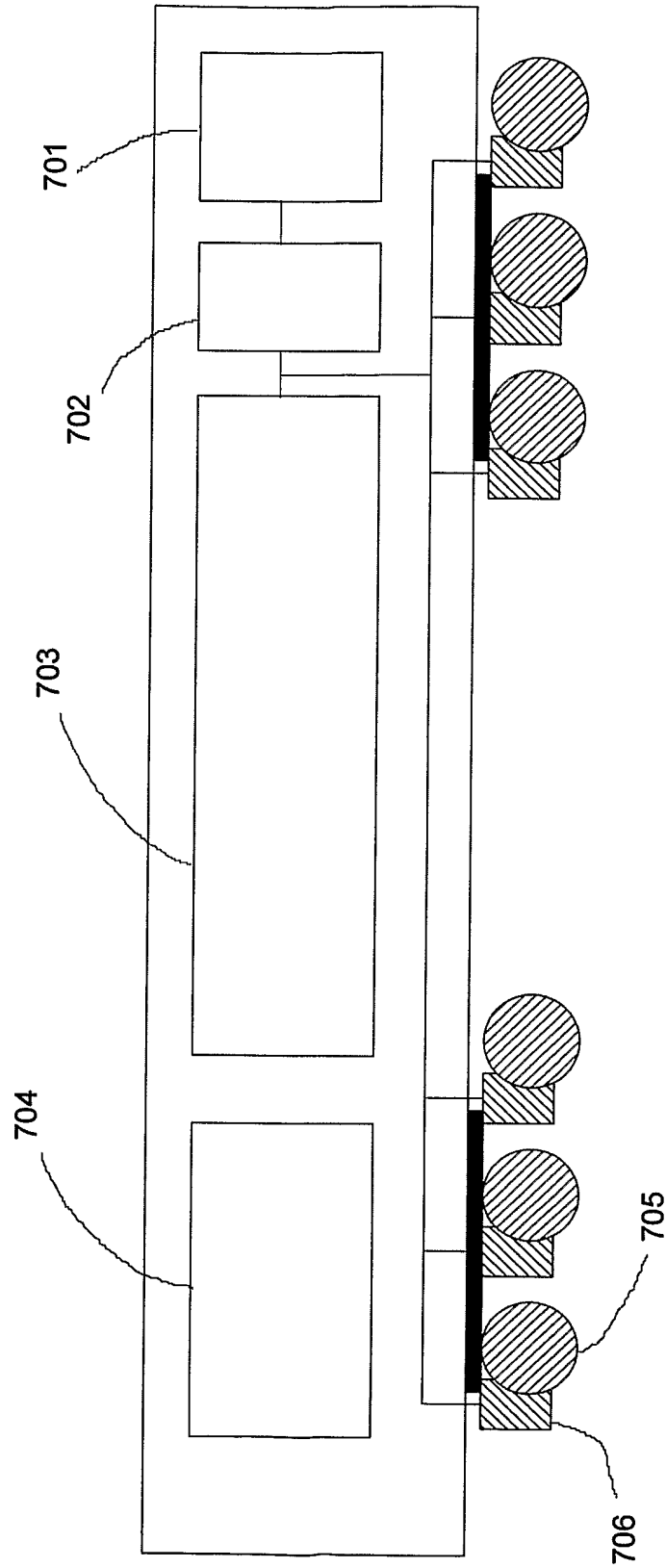

Figure 1

800

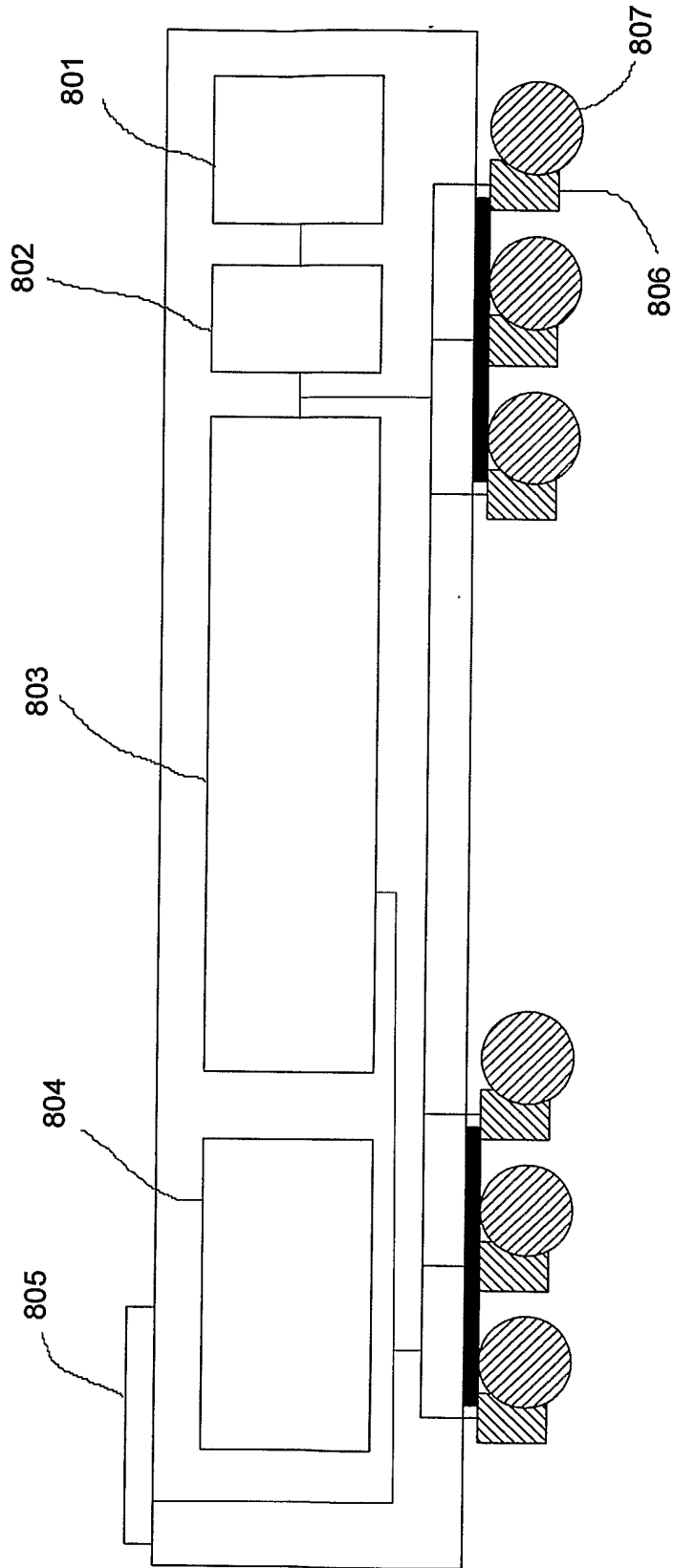

Figure 2

900

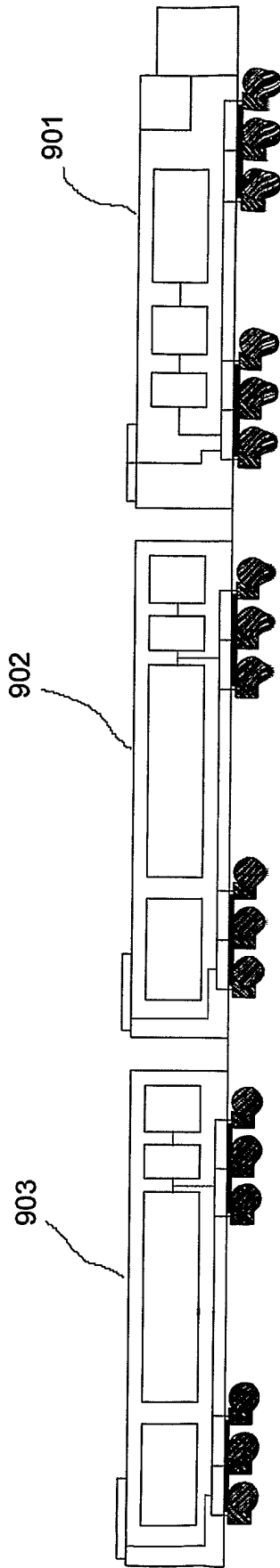

Figure 3

1000

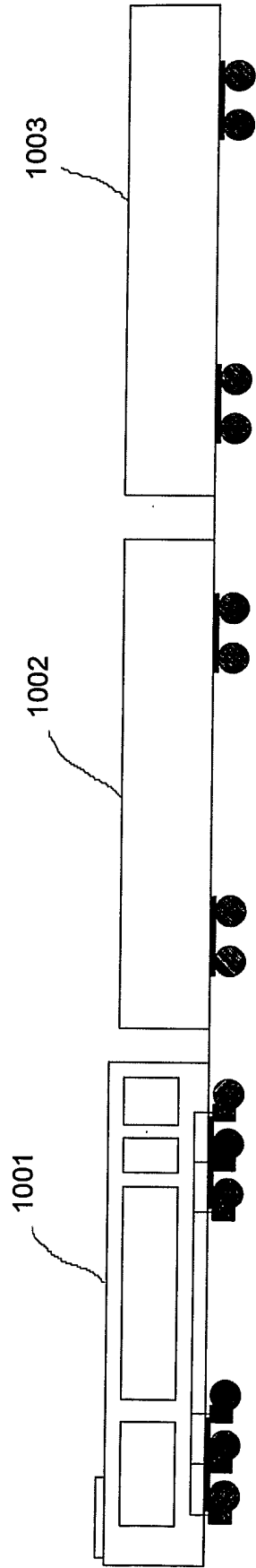

Figure 4

1200

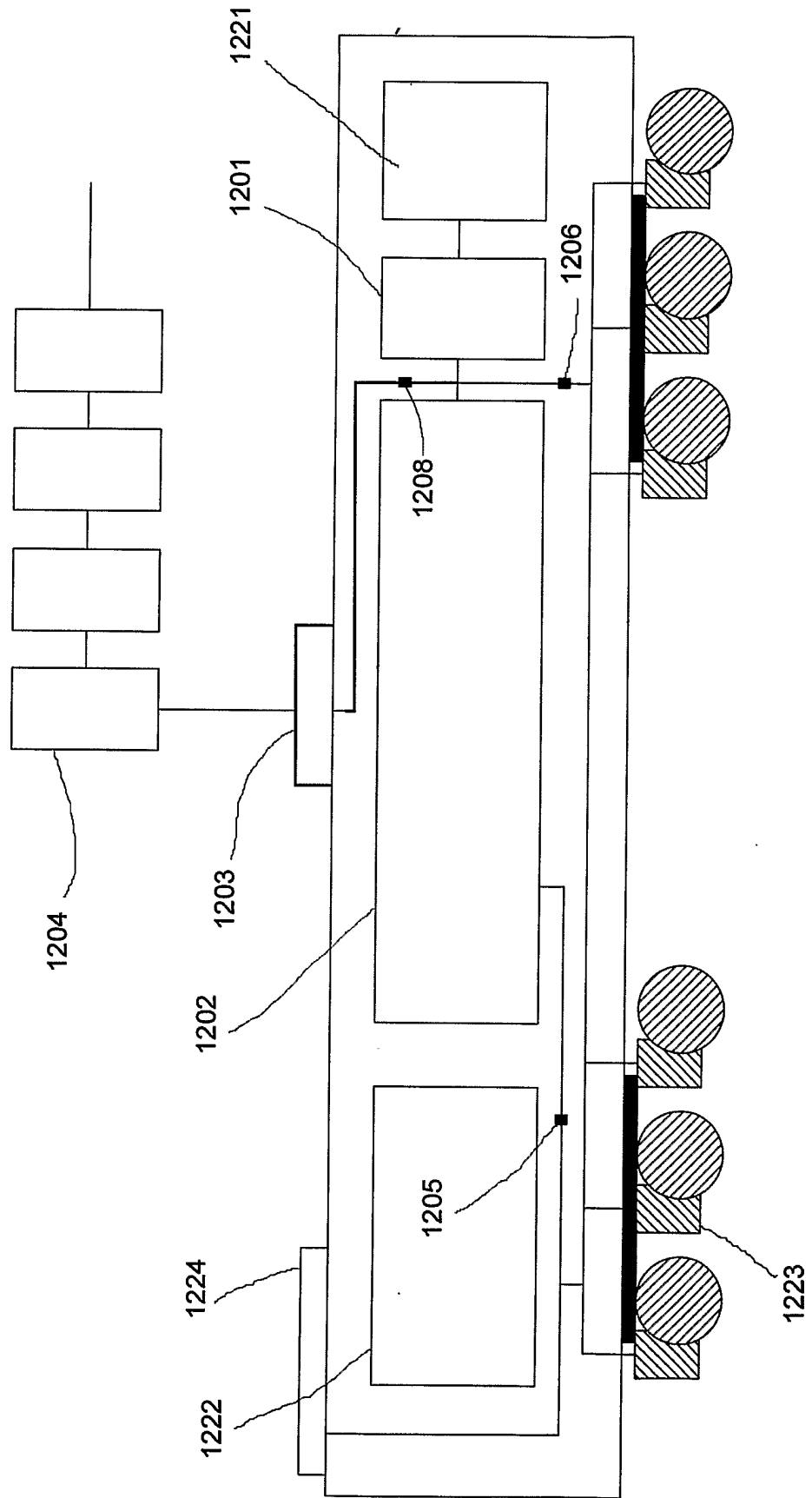

Figure 5

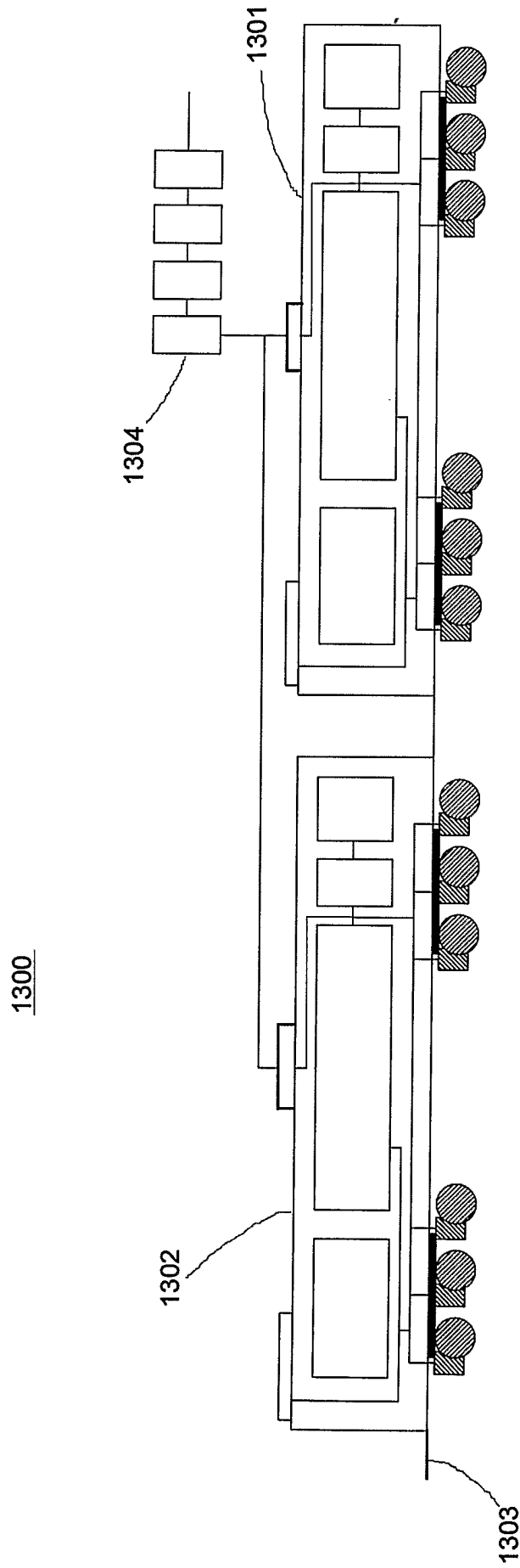

Figure 6

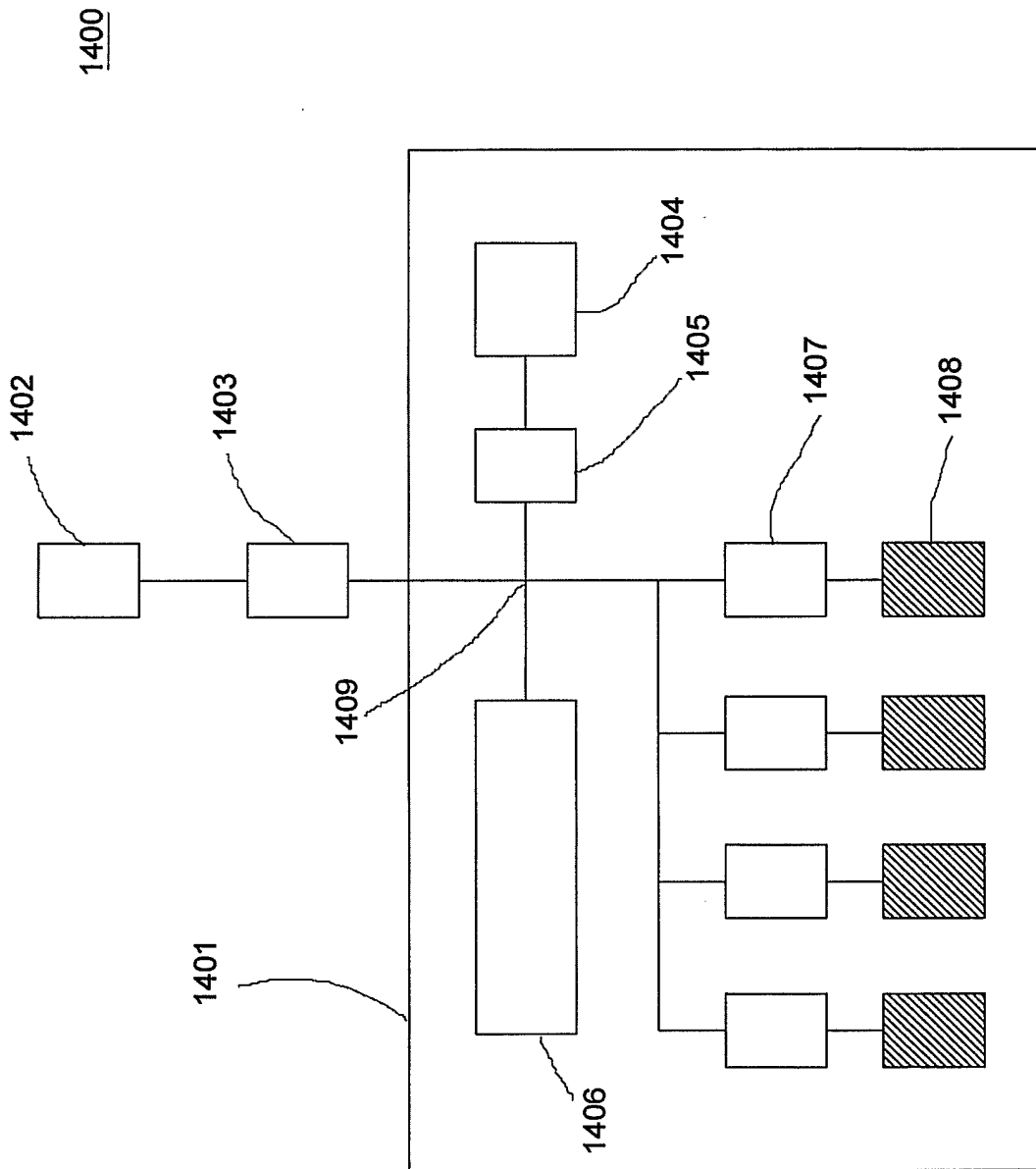

Figure 7

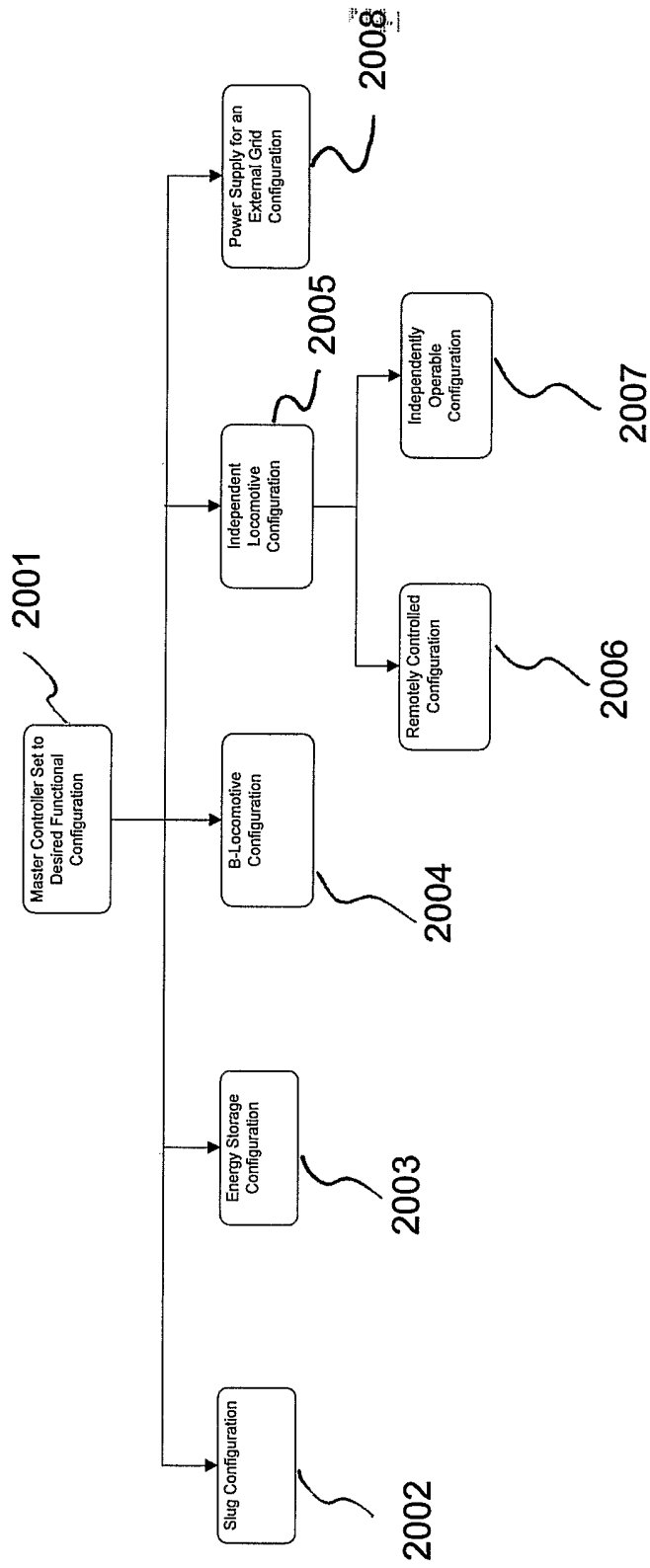

Figure 8

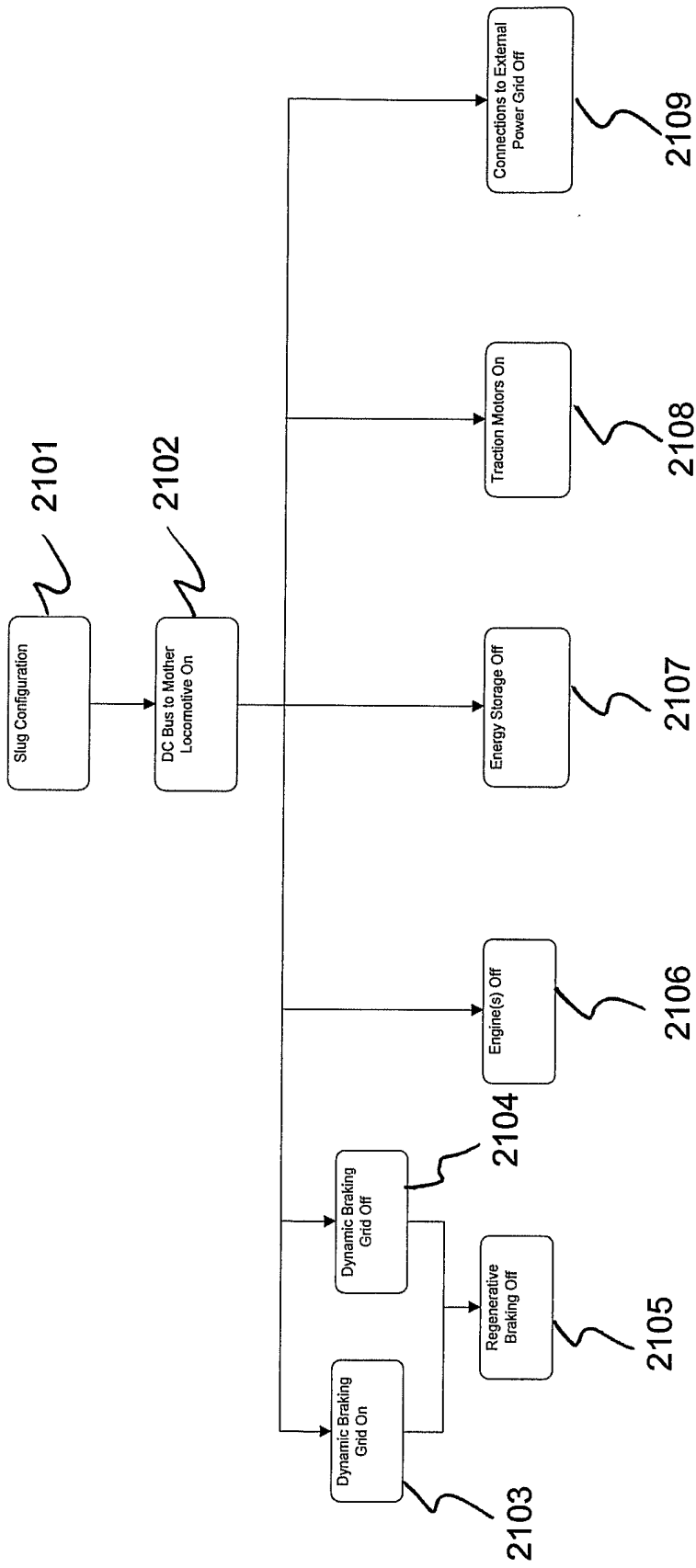

Figure 9

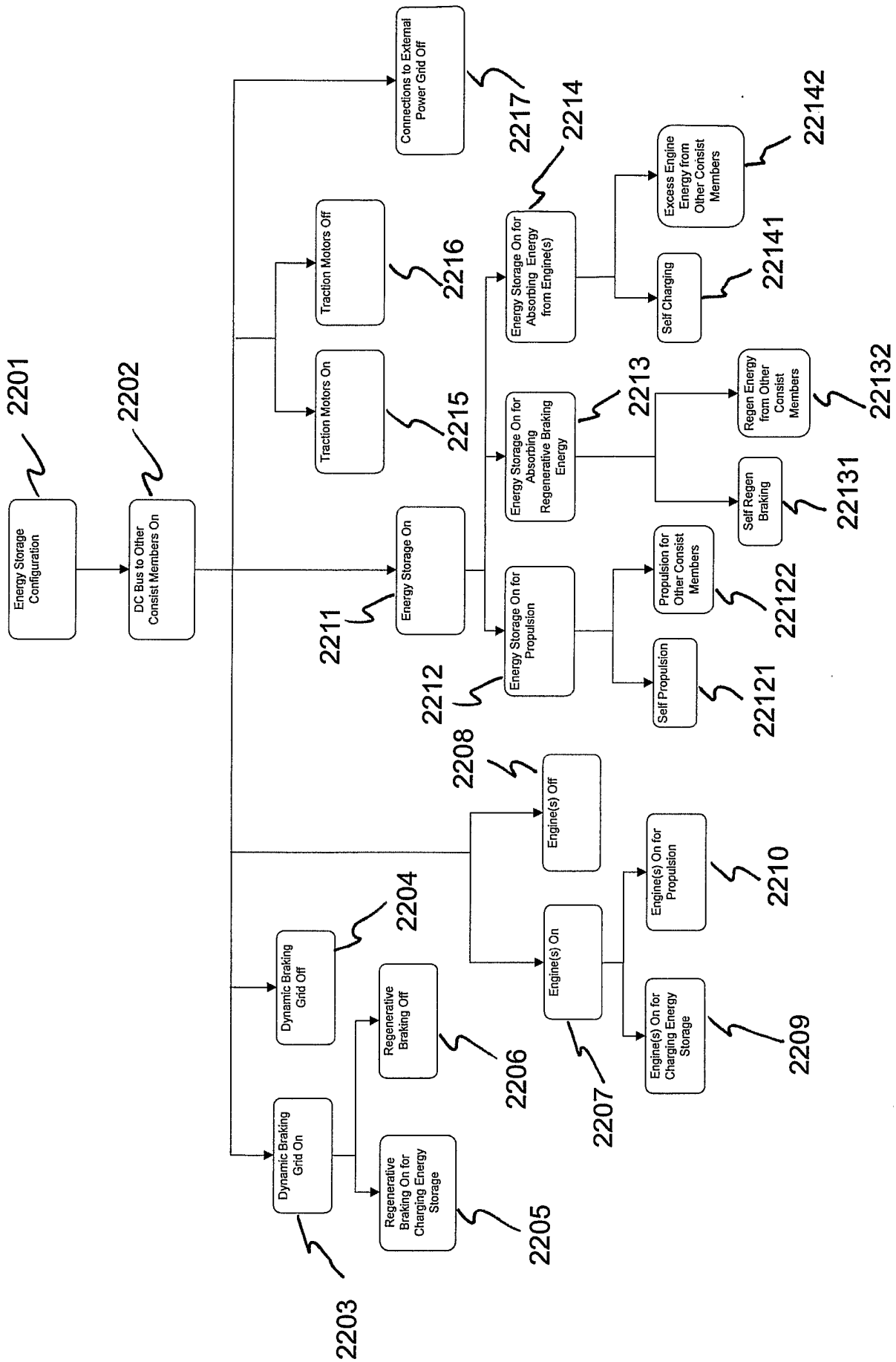

Figure 10

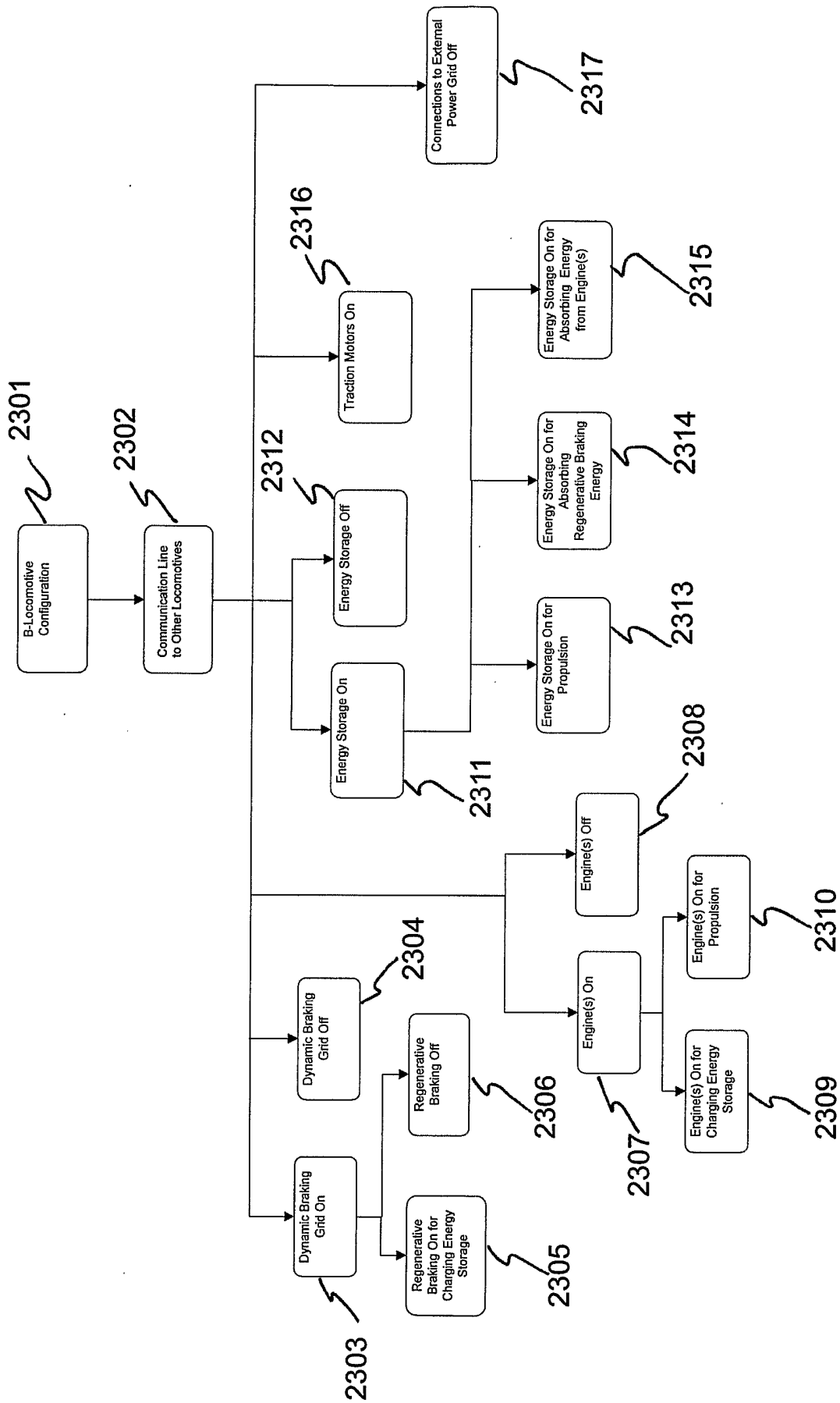

Figure 11

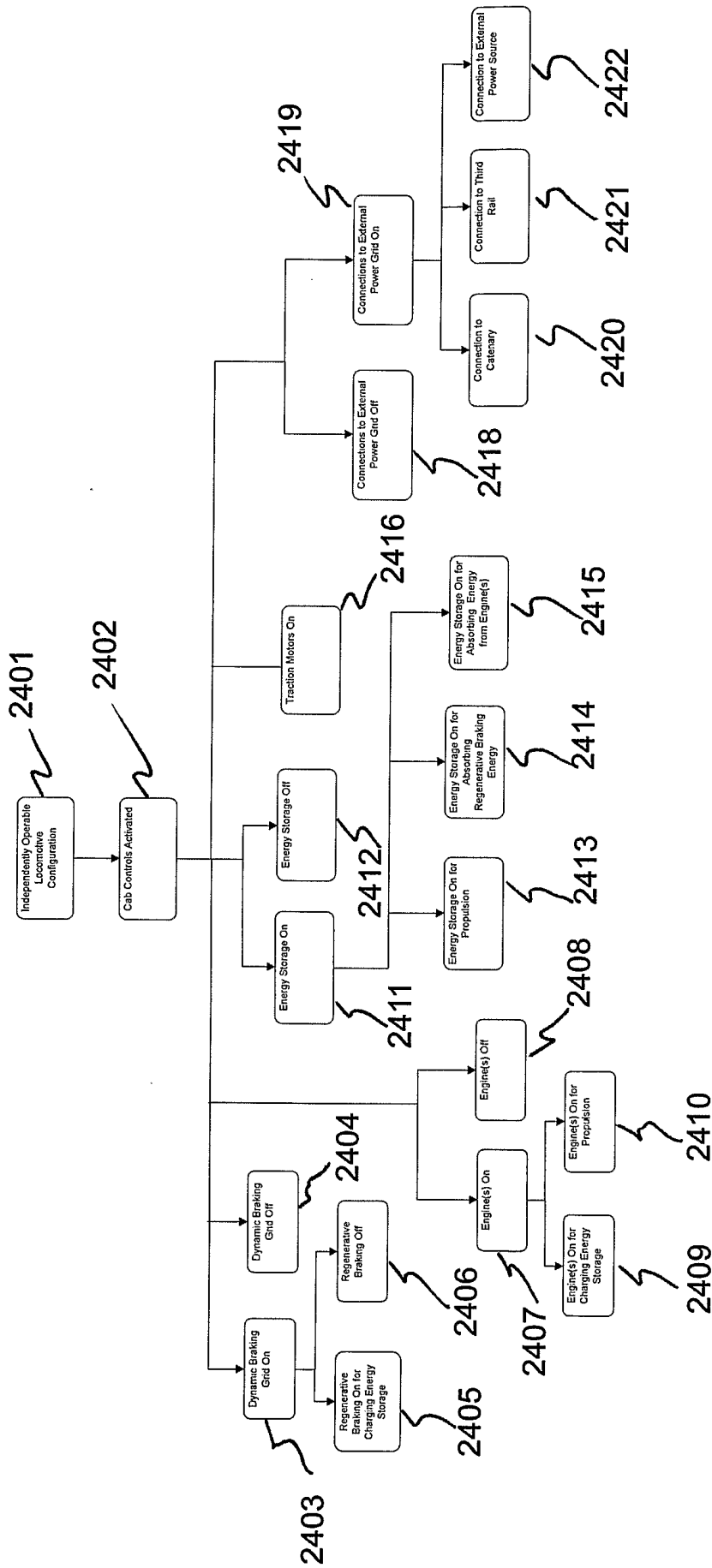

Figure 12

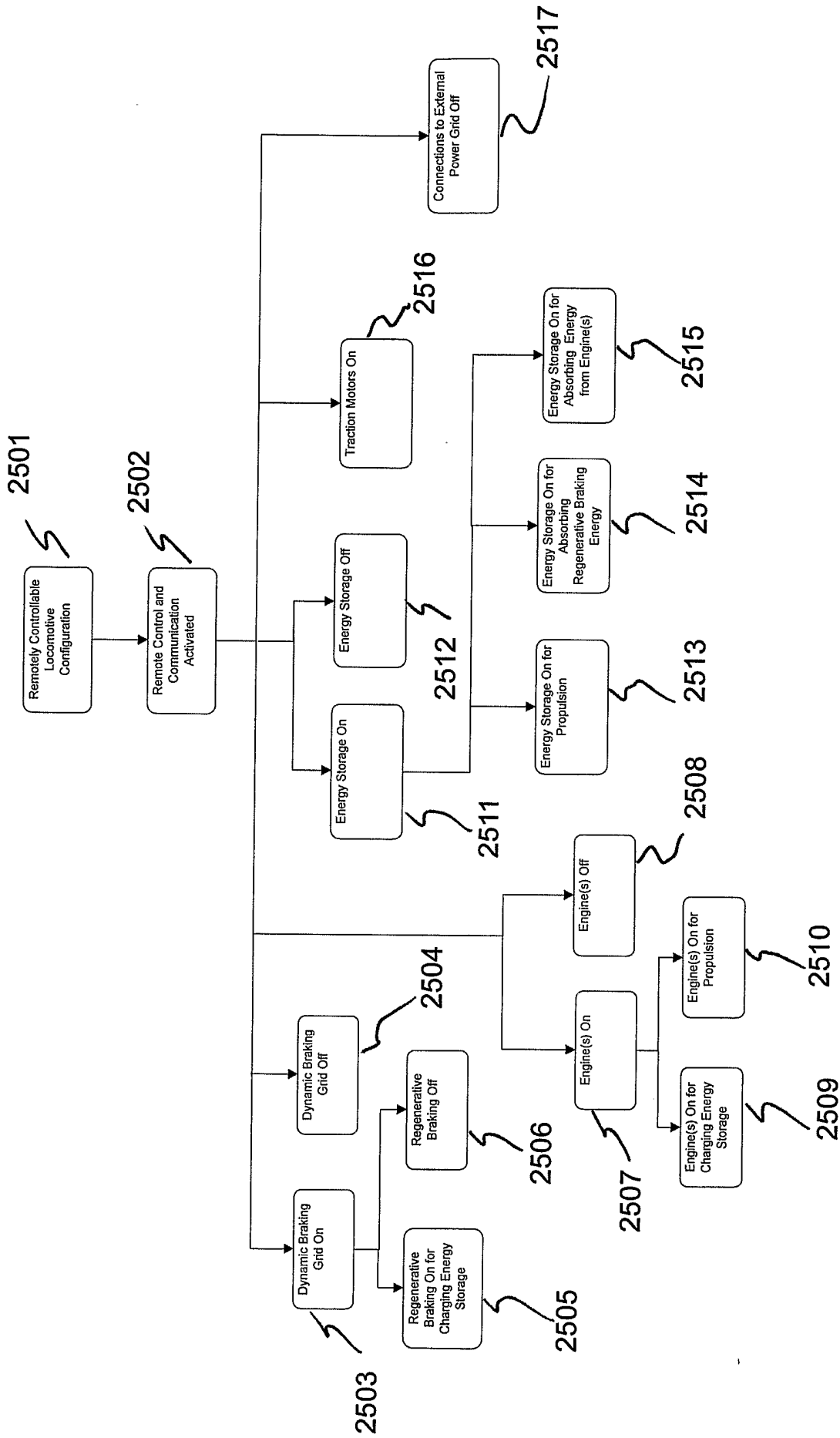

Figure 13

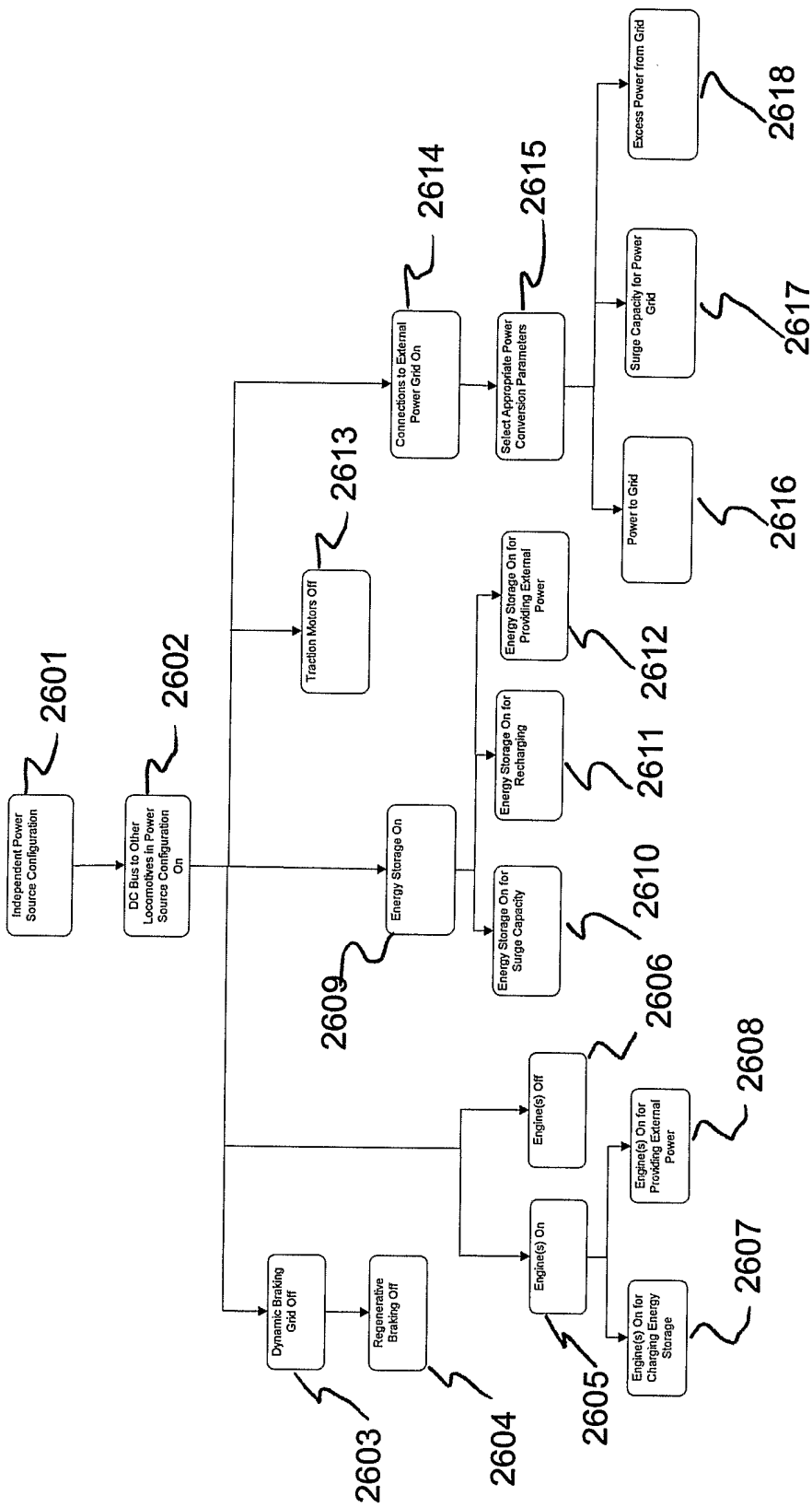

Figure 14

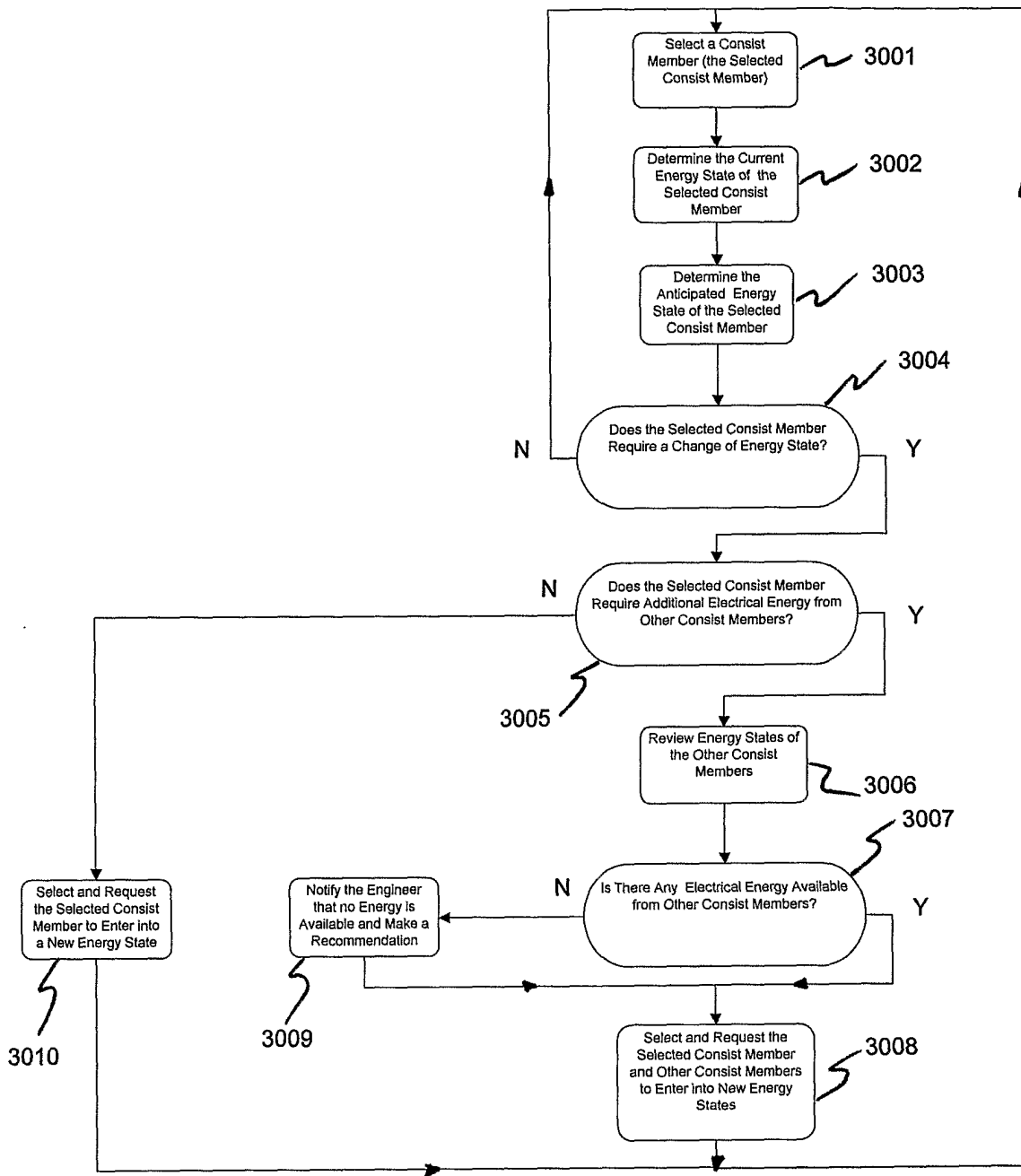

Figure 15