

(19) World Intellectual Property
Organization
International Bureau



(43) International Publication Date
16 June 2005 (16.06.2005)

PCT

(10) International Publication Number
WO 2005/055363 A1

- (51) International Patent Classification⁷: **H01Q 1/36**, B21F 45/00, H01R 11/09
- (21) International Application Number: PCT/AU2004/001726
- (22) International Filing Date: 8 December 2004 (08.12.2004)
- (25) Filing Language: English
- (26) Publication Language: English
- (30) Priority Data:
2003906787 8 December 2003 (08.12.2003) AU
2004905355 16 September 2004 (16.09.2004) AU
- (71) Applicant (for all designated States except US): **COCHLEAR LIMITED** [AU/AU]; 14 Mars Road, Lane Cove, NSW 2066 (AU).
- (72) Inventors; and
- (75) Inventors/Applicants (for US only): **HO, Andy** [AU/AU]; 14 Mars Road, Lane Cove, 2066 (AU). **EDER, Niki** [AU/AU]; 14 Mars Road, Lane Cove, 2066 (AU). **WALKER, David** [AU/AU]; 14 Mars Road, Lane Cove, 2066 (AU). **MEAGHER, Kate** [AU/AU]; 14 Mars Road, Lane Cove, 2066 (AU). **SCHULLER, Peter** [AU/AU]; 14 Mars Road, Lane Cove, 2066 (AU).
- (74) Agent: **F B RICE & CO**; 605 Darling Street, Balmain NSW 2041 (AU).
- (81) Designated States (unless otherwise indicated, for every kind of national protection available): AE, AG, AL, AM, AT, AU, AZ, BA, BB, BG, BR, BW, BY, BZ, CA, CH, CN, CO, CR, CU, CZ, DE, DK, DM, DZ, EC, EE, EG, ES, FI, GB, GD, GE, GH, GM, HR, HU, ID, IL, IN, IS, JP, KE, KG, KP, KR, KZ, LC, LK, LR, LS, LT, LU, LV, MA, MD, MG, MK, MN, MW, MX, MZ, NA, NI, NO, NZ, OM, PG, PH, PL, PT, RO, RU, SC, SD, SE, SG, SK, SL, SY, TJ, TM, TN, TR, TT, TZ, UA, UG, US, UZ, VC, VN, YU, ZA, ZM, ZW.
- (84) Designated States (unless otherwise indicated, for every kind of regional protection available): ARIPO (BW, GH, GM, KE, LS, MW, MZ, NA, SD, SL, SZ, TZ, UG, ZM, ZW), Eurasian (AM, AZ, BY, KG, KZ, MD, RU, TJ, TM), European (AT, BE, BG, CH, CY, CZ, DE, DK, EE, ES, FI, FR, GB, GR, HU, IE, IS, IT, LT, LU, MC, NL, PL, PT, RO, SE, SI, SK, TR), OAPI (BF, BJ, CF, CG, CI, CM, GA, GN, GQ, GW, ML, MR, NE, SN, TD, TG).
- Published:**
— with international search report
- For two-letter codes and other abbreviations, refer to the "Guidance Notes on Codes and Abbreviations" appearing at the beginning of each regular issue of the PCT Gazette.

(54) Title: COCHLEAR IMPLANT ASSEMBLY

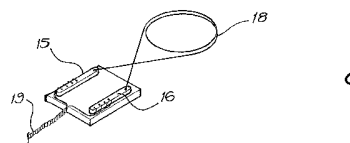
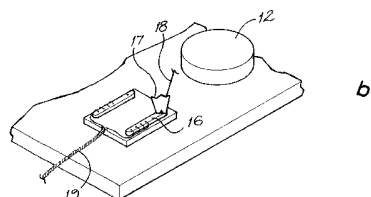
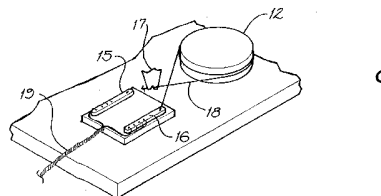
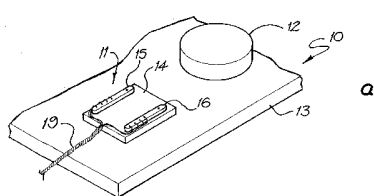

(57) Abstract: A method of forming and connecting an antenna to a feedthrough member of a housing. The method comprising a step of: positioning the feedthrough member and an antenna template relative to each other. A step of connecting the first portion of at least one electrically conducting wire to the feedthrough member. An additional step of winding the wire at least once around the antenna template, and a further step of connecting a second portion of each wire to said feedthrough member.

WO 2005/055363 A1

"Cochlear implant assembly"Cross-Reference to Related Applications

5 The present application claims priority from Provisional Patent Application Nos 2003906787 and 2004905355 filed on 8 December 2003 and 16 September 2004, respectively, the contents of which are incorporated herein by reference.

Field of the Invention

10

The present invention relates generally to the field of forming miniature wiring and connector systems for electrical products. More specifically, the present invention relates to a method of forming electrical contacts with wiring and connector systems, antenna coils and electrode arrays, such as arrays for sensors, including biosensors, and
15 implantable devices, such as an implantable recording or stimulating electrodes or pads for use in the body.

Background of the Invention

20 In many electrical devices, particularly those that are manufactured on a very small scale, the manufacture of the wiring and connector components is often a labour intensive and specialised craft. Ensuring that the wiring and connection of the various components of the systems occurs correctly is often the most expensive and labour intensive aspect of the manufacturing process, resulting in large costs associated with
25 the time taken to manufacture the device which is often passed on to the ultimate consumer. This is also the case when such devices need to be specifically hand-made to a specification as often the availability of the device is dependent upon the time taken to manufacture the device, with the time taken being difficult or impossible to expedite.

30

This is particularly the case in the field of medical implants and electrical devices that are implanted in the body to perform a specific task. Such devices may include: stimulating devices such as pacemakers, cochlear implants, FES stimulators,
35 recording devices such as neural activity sensors and the like, implantable cables which may be used to connect implantable devices to other implantable devices or

stimulating/sensing devices, diagnostic devices capable of carrying out in-vivo analysis of body parameters, and other types of implantable devices not yet contemplated. In such devices, the size needs to be minimised to ensure that they are minimally invasive upon implantation. As a result, in such instances, the electronic wiring and connections
5 need also to be relatively very small. As such, manufacturing such devices to ensure that they are reliable and sturdy is a specialised art, and requires much time and expense.

Current techniques for the manufacture of electrode arrays for cochlear implant
10 systems, in particular, are relatively highly labour intensive. This is in the main due to the intricate nature of the array and the very small dimensions of the array necessary to allow it to be inserted in the scala tympani of the human cochlea. Being an implantable device, the method of manufacture also needs to result in a biocompatible product that is not susceptible to damage from long-term placement in the body.

15

With implanted devices and miniaturisation becoming more common, there is an increasing need to provide electronic wiring and electronic connections in such systems that are both relatively simple and reliable.

20 Any discussion of documents, acts, materials, devices, articles or the like which has been included in the present specification is solely for the purpose of providing a context for the present invention. It is not to be taken as an admission that any or all of these matters form part of the prior art base or were common general knowledge in the field relevant to the present invention as it existed before the priority date of each claim
25 of this application.

Summary of the Invention

Throughout this specification the word "comprise", or variations such as
30 "comprises" or "comprising", will be understood to imply the inclusion of a stated element, integer or step, or group of elements, integers or steps, but not the exclusion of any other element, integer or step, or group of elements, integers or steps.

In a first aspect, the present invention is a method of forming and connecting an
35 antenna to a feedthrough member of a housing, the method comprising:

3.

(a) positioning the feedthrough member and an antenna template relative to each other;

(b) connecting a first portion of at least one electrically conducting wire to said feedthrough;

5 (c) winding said wire at least once around the antenna template; and

(d) connecting a second portion of each wire to said feedthrough member.

In this aspect, the steps can be performed in the order set out above. It will be appreciated that at least some of the steps could be performed in other orders or
10 simultaneously. For example, step (c) could be performed prior to or at the same time as step (b) or step (a). Still further, step (d) could be performed prior to the other steps.

In this aspect, step (a) can include removably mounting the feedthrough member to a workspace member. In one embodiment, the antenna template can also be
15 removably or non-removably mounted to this workspace member. In another embodiment, the antenna template can be an integral component of the workspace member.

In yet another embodiment, the feedthrough member can comprise a first
20 portion and a second portion, the first and second portions being mountable or mounted in the chassis of the housing. Respective conductive posts can extend through these portions and are all preferably electrically insulated from each other. The feedthrough member is adapted to provide electrical connection through the chassis or wall of the housing whilst also ensuring hermetic sealing of the housing.

25

In one embodiment, step (b) can comprise connecting the wire to the first portion of the feedthrough member and step (d) can comprise connecting the wire to the second portion of the feedthrough member. In an alternative embodiment, step (b)
30 can comprise connecting the wire to the second portion of the feedthrough member and step (d) can comprise connecting the wire to the first portion of the feedthrough member.

The wire can be connected to the feedthrough member using a wire bonder. Alternative techniques may be utilised including welding and crimping.

35

In a further embodiment, the first portion of the wire can comprise an end of the wire. It will be appreciated that the connection could be made at a location away from the end of the wire. In this case, however, it is envisaged that the wire would then be trimmed.

5

In yet another embodiment, the step of connecting the second portion of the wire to the feedthrough member (i.e. step (d)) can be made at a location along the wire that is distal from the first portion. In this case, however, it is envisaged that the wire would then be trimmed at the location of the connection to the feedthrough member. Despite
10 the connection of the second portion of the wire being at a distal location along the wire, it will be appreciated that the second portion and first portion of the feedthrough member can be relatively close to each other.

In one embodiment, more than one wire can be connected to the feedthrough
15 member and wound around the antenna template including, for example, a multistrand wire. In this or another embodiment, the wire can be wound around the antenna template more than one time. For example, the wire can be wound around the template twice.

20 The wire can be formed from a biocompatible electrically conductive material. In a preferred embodiment, the wire is formed from a suitable metal or metal alloy. In one embodiment, the wire can be formed from platinum or platinum/iridium alloy. In one embodiment, the wire is circular in cross-section. Other shapes of wire are envisaged, including wires that are oval in cross-section, or are foil-like having a width
25 greater than its thickness.

In one embodiment, the wire can be coated with an electrically insulating material, such as a polymer material. In one embodiment, the electrical connection formed between the wire and the feedthrough member can be performed through the
30 insulating layer.

In another embodiment, the wire can be uncoated when electrically connected to the feedthrough member. In this case, it is envisaged that the antenna formed by the method according to the first aspect would undergo a coating step where at least the
35 wire is encapsulated in an electrically insulating material.

For example, the antenna could be passed through a parylene coater so as to coat at least parts of the antenna with a suitable layer of parylene. In this case, it is envisaged that, if necessary, certain parts of the feedthrough would be masked to prevent their coating with parylene.

5

At the completion of step (d), the formed antenna and the feedthrough can be removed from the workspace member.

10 In one embodiment, the method can further include the step of encapsulating the housing, feedthrough and antenna in an electrically insulating material. This material is further also preferably biocompatible and resiliently flexible. One example of a possible encapsulating material is silicone. If desired, the formed device can undergo further processing, including washing and drying, to render it suitable for implantation.

15 The antenna template can comprise a cylinder. As such, the wound wire can define a circular locus. It will be appreciated that other shapes might be suitable and could be utilised to form the antenna.

20 The formed antenna can comprise a receiver antenna. The method has potential advantages in providing a relatively efficient and inexpensive process of antenna manufacture, particularly assembly of receiver antennae for implantable tissue-stimulating devices, such as cochlear implants. The present invention further provides a method of forming an antenna that can allow the manufacturing process to become automated or semi-automated so providing a desirable alternative to current
25 manufacturing processes which require extensive labour input and increased manufacturing throughput.

According to a second aspect, the present invention is an antenna and feedthrough member assembly when formed by the method as defined herein.

30

In one embodiment of this aspect, the antenna can be a receiver antenna. The antenna and feedthrough assembly can be suitable for use in tissue-stimulating and sensor applications or otherwise as described herein.

According to a third aspect, the present invention is a method of forming a non-linear path of at least a portion of at least one electrically conducting wire extending between a first location and a second location, the method comprising:

- (a) forming a wire path template defining a non-linear path; and
- 5 (b) winding said wire through said template such that said wire adopts said non-linear path; and
- (c) removing the wire from said template.

As used below, it will be appreciated that the term "wire" can encompass a
10 plurality of wires including, for example, a multistrand wire.

In one embodiment, the wire path template can be removably or non-removably mounted to a workspace member. In another embodiment, the wire path template can be an integral component of the workspace member.

15

In another embodiment of the third aspect, a feedthrough member of a housing can be removably mounted to the workspace member. In this embodiment, the feedthrough member can comprise the first location. Where the feedthrough is present, the method can comprise a step of connecting the wire to the feedthrough member. In
20 one embodiment, an end of the wire can be connected to the feedthrough member. It will be appreciated that the connection could be made at a location away from the end of the wire. In this case, however, it is envisaged that the wire would then be trimmed.

In one embodiment, the wire path template is adapted to form an undulating
25 wire path over said portion of the wire. For example, the formed wire path can be sinusoidal or substantially so. In this embodiment, the wire path template can comprise a series of spaced posts that define the path and about which the wire is to be wound.

In one embodiment, the wire can be adapted to provide electrical connection to
30 one or more electrodes. In one embodiment, the wire can provide electrical connection to one or more extracochlear electrodes. In another embodiment, the wire can provide electrical connection to one or more intracochlear electrodes.

The non-linear path of said portion of the wire provides a degree of flexibility to
35 the wire following implantation. For example, the non-linear path can be adapted to

compensate for any movement between the housing and the one or more electrodes, such as movement which may occur naturally due to body growth.

The wire can be connected to the feedthrough member using a wire bonder. The wire bonder can also be utilised to wind the wire through the path of the wire path template. Alternative connection techniques can be envisaged including welding and crimping.

In this aspect, the wire can be formed from a biocompatible electrically conductive material. In a preferred embodiment, the wire is formed from a suitable metal or metal alloy. In one embodiment, the wire can be formed from platinum or platinum/iridium alloy. In one embodiment, the wire is circular in cross-section. Other shapes of wire are envisaged, including wires that are oval in cross-section, or are foil-like having a width greater than its thickness.

15

In one embodiment, the wire can be coated with an electrically insulating material, such as a polymer material. In one embodiment, the electrical connection formed between the wire and the feedthrough member can be performed through the insulating layer.

20

In another embodiment, the wire can be uncoated when electrically connected to the feedthrough member. In this case, it is envisaged that the wire formed by the method according to the first aspect would undergo a coating step where the wire is encapsulated in an electrically insulating material.

25

For example, the wire could be passed through a parylene coater so as to coat at least parts of the antenna with a suitable layer of parylene. In this case, it is envisaged that, if necessary, certain parts of the feedthrough would be masked to prevent their coating with parylene.

30

In one embodiment of this aspect, the method can further include the step of encapsulating the housing, feedthrough and at least some of the wire in an electrically insulating material. This material is further also preferably biocompatible and resiliently flexible. One example of a possible encapsulating material is silicone. If desired, the formed device can undergo further processing, including washing and drying, to render it suitable for implantation.

35

According to a fourth aspect, the present invention is a wire having a portion thereof defining a non-linear path when formed by the method as defined herein according to the third aspect of the invention.

5

In a preferred embodiment, the antenna and/or wire as defined herein are for use as an implantable tissue-stimulating device. More preferably, the tissue-stimulating device is a cochlear electrode assembly, including an intracochlear electrode assembly. In another embodiment, the electrode array could be used in a biosensor not necessarily
10 related to an implanted device.

In this case, the feedthrough member provides electrical connection through the wall of an implantable component, such as a receiver/stimulator unit.

15 In a fifth aspect, the present invention is a method of forming a device comprised of a predetermined pattern of at least two relatively electrically conductive regions, the method comprising:

(a) working a sheet of electrically conductive material to remove predetermined portions therefrom to form said two or more discrete relatively
20 conducting regions;

(b) connecting at least one electrically conducting wire to at least one of said at least two or more relatively conducting regions; and

(c) connecting a portion of each wire located distal said conducting regions to a common sacrificial member.

25

In this fifth aspect, the steps can be performed in the order set out above. It will be appreciated that at least some of the steps could be performed in other orders or simultaneously. For example, step (c) could be performed prior to or at the same time as step (b) or step (a).

30

In this fifth aspect, the step of working the sheet (i.e. step (a)) can include a step of punching portions out of the sheet of electrically conductive material. In this embodiment, portions of the sheet are removed and separated from the sheet.

35 Yet further, the step of working the sheet can include a step of slicing or cutting the sheet of electrically conductive material.

In yet another embodiment of this aspect, the step of working the sheet can comprise a process of using electrical discharge machining (EDM), which is also known as spark erosion, to remove unwanted portions of the sheet as is described in the present applicant's International Publication No WO 02/089907, the contents of which are incorporated herein by reference.

In a further embodiment of this aspect, the step of connecting the wires (i.e. step (b)) can comprise a step of welding each wire to a respective relatively conducting region. In one embodiment, a distal end of the wire is welded to the conducting region. It will be appreciated that the connection could be made at a location away from the end of the wire. In this case, however, it is envisaged that the wire would then be trimmed.

In yet another embodiment of this aspect, the step of connecting a proximal portion of the wire to a sacrificial member (i.e. step (c)) can comprise a step of welding each wire to the sacrificial member. In one embodiment, a proximal end of the wire is welded to the sacrificial member. It will be appreciated that the connection could be made at a location away from the proximal end of the wire. In this case, however, it is envisaged that the wire would then be trimmed at the location of the weld.

In one embodiment of this aspect, each of the wires can be individually welded to their respective conductive region and the sacrificial member. In another embodiment, two or more wires can be welded simultaneously, at one or both locations. In another embodiment, all of the wires can be welded simultaneously, at one or both locations. In a further embodiment, the welding can be performed manually. In a preferred embodiment, an automatic welding machine can be used to weld the wires to the conductive regions and the sacrificial member.

It is preferred that the wires are welded to the sacrificial member in a manner that allows ready identification as to which conductive region the wire is extending from. For example, the proximal ends of the wires can be aligned transversely along the sacrificial member. For example, where there are a plurality of conductive regions disposed in a longitudinal array and the same number of wires extending therefrom, the wire extending from the region that is most distal the sacrificial member can be at one end of the member, the wire from the next most distal region beside it, and so on until

each of the wires are electrically connected, such as by welding, to the sacrificial member.

This ordering of the connection of the wires to the sacrificial member results in
5 there being no need to retest which wire is connected to which conductive region at a later date in a manufacturing process that uses the device according to the fifth aspect. Instead, it is possible by noting the location of the weld of the wire to the sacrificial member to determine which conductive region that wire is extending from.

10 The wire can be formed from a biocompatible electrically conductive material. In a preferred embodiment, the wire is formed from a suitable metal or metal alloy. In one embodiment, the wire can be formed from platinum or platinum/iridium alloy. In one embodiment, the wire is circular in cross-section. Other shapes of wire are envisaged, including wires that are oval in cross-section, or are foil-like having a width
15 greater than its thickness.

In one embodiment, the wire can be coated with an electrically insulating material, such as a polymer material. In one embodiment, the electrical connection formed between the wire and the conductive region and/or sacrificial member, such as
20 the formation of a weld, can be performed through the insulating layer.

In another embodiment of the fifth aspect, the wire can be uncoated when electrically connected to the conductive region and/or sacrificial member. In this case, it is envisaged that the device formed by the method according to the fifth aspect would
25 undergo a coating step where at least the wires are encapsulated in an electrically insulating material.

For example, the device could be passed through a parylene coater so as to coat at least parts of the device with a suitable layer of parylene. In this case, it is envisaged
30 that the electrically conductive regions would be masked to prevent their coating with parylene.

In one embodiment, the method can further include the step of encapsulating the device in an electrically insulating material. This material is further also preferably
35 biocompatible and resiliently flexible. One example of a possible encapsulating material is silicone. The result is preferably a plurality of separate electrically

independent conductive portions having a layer of silicone encapsulated on one side thereof. If desired, the formed device can undergo further processing, including washing and drying, to render it suitable for implantation.

5 In one embodiment, the sacrificial member is in the form of a plate. The sacrificial member as its name implies is adapted to be sacrificed when the device made by the method according to the fifth aspect is ready to be utilised for the purpose for which it was manufactured. In one embodiment, the plate is preferably formed from a suitable metal to allow welding of the distal ends of the wires to the plate.

10

In a preferred embodiment, the device formed by the method according to the fifth aspect is preferably an electrode array for an electrode assembly. The method has potential advantages in providing a relatively efficient and inexpensive process of electrode assembly manufacture, particularly assembly of intracochlear electrode assemblies. The present invention further provides a method of forming an electrode array for an electrode assembly that preferably allows the manufacturing process to become automated or semi-automated so providing a desirable alternative to current manufacturing processes which require extensive labour input and increased manufacturing throughput.

15

In a preferred embodiment, the electrode array is for use as an implantable tissue-stimulating device. More preferably, the tissue-stimulating device is a cochlear electrode assembly, more preferably an intracochlear electrode assembly. In another embodiment, the electrode array could be used in a biosensor not necessarily related to an implanted device.

20

In this embodiment, the electrically conductive regions formed in step (a) comprise the plurality of stimulating pads or electrodes of the array. The wires are welded to these electrodes and extend therefrom to a sacrificial plate. The wires remain welded to the plate until such time as the array is required for the manufacturing process in which the wires are connected to a feedthrough device that provides electrical connection through the wall of an implantable component, such as a receiver/stimulator unit. In this regard, the wires can be cut away from the plate when connection needs to be made to the feedthrough. The plate can then be disposed of or re-used.

25

30

35

In one embodiment of the fifth aspect, the sheet of electrically conductive material worked in step (a) is a biocompatible material. In a preferred embodiment, the sheet is a metallic material. Still further, the metallic material is a sheet of platinum. In a further embodiment, the sheet can be annealed. In a further embodiment, each of the electrodes is formed from a single sheet of electrically conductive material, such as platinum. In a further embodiment, more than one array can be formed from a single sheet of platinum. In yet a further embodiment, the sheet could be a laminate of two or more layers (eg Pt & Ir), or could be an alloy.

10 The sheet preferably has a thickness between about 10 and 200 microns, more preferably between about 20 and 100 microns. The method preferably uses a sheet of platinum having a thickness of around 50 microns. Other suitable thicknesses can be envisaged. Each sheet can have dimensions of about 50mm x 250mm. The size of the sheet will though depend on the requirements of the tooling used to work the sheet. As
15 such, sheets of different dimensions can be envisaged.

The wires are preferably linearly aligned for at least a majority, and preferably all, of their length extending away from the electrode array. In one embodiment, the wires can be disposed for at least a portion of their lengths in a parallel arrangement.

20

The sheet of conductive material can, before the working step, be a planar sheet. Sheets that already have folds or embossments formed therein prior to the working step of the present invention can, however, also be envisaged.

25 In one embodiment, the step of working the sheet can further comprise deforming at least a portion of the planar sheet in a third dimension. For example, once a plurality of planar conductive electrodes are at least partially formed, they can be placed in a concave moulding die in which they are deformed to adopt a curved configuration. In one embodiment, this step can occur prior to step (b). Where the
30 electrodes have a curved configuration, the wires can be joined, such as by automatic welding, to the concave surfaces of the respective electrodes.

In one embodiment, the respective electrodes formed from a planar sheet can be substantially rectangular or rectangular. Other suitable shapes for the formed
35 electrodes can, however, be envisaged. In one embodiment, the portions of the sheet removed from the sheet can be bone-shaped.

In producing an electrode array, it is firstly desirable to determine the configuration of the stimulating pads desired for the electrode array. Once the configuration is determined, the step of working the sheet can comprise working the sheet, such as by using a punch that is fabricated for use in the method or other technique as defined herein, so as to produce the desired electrode array configuration.

Various techniques for punching, cutting, and otherwise working the sheet are also described in International Patent Publication No. WO 02/089907 already referenced herein.

In one embodiment, two or more arrays formed using the method can be laminated together to form a single tissue stimulating electrode assembly. In one embodiment, the assembly can be formed from a first lamination having 7 electrodes, a second lamination having 8 electrodes and a third lamination having 8 electrodes, to form an electrode assembly having 23 electrodes. In the case of a cochlear electrode array, the formed array will preferably have 22 intracochlear electrodes and one extracochlear electrode. Such a lamination process preferably results in a linear array of the 22 electrodes. It will be appreciated that other combinations of layers and other numbers of electrodes in each layer could be utilised to form arrays of different lengths, up to around 100 electrodes.

It will be appreciated that it is generally important that the lead which is comprised of the wires extending from the array to the feedthrough is capable of a degree of flexibility to compensate for any movement between the stimulator and the electrodes, such as movement which may naturally occur due to body growth. In one embodiment, the method can comprise a still further step of winding the lead in a helical manner. In one embodiment, the winding can result in the lead having a helical portion. The winding can be such that the wires extend over the same longitudinal extent in the helical portion. Techniques for forming the winding are described in the present applicant's International Application No. PCT/AU03/01369; the contents of which are incorporated herein by reference.

According to a sixth aspect, the present invention is a device when formed by the method as defined herein comprising:

a predetermined pattern of at least two electrically conductive regions; and

at least one wire extending from each of the conductive regions to a common sacrificial member.

In one embodiment of this sixth aspect, the device is preferably an electrode array. The electrode array can be suitable for use in tissue-stimulating and sensor applications or otherwise as defined herein with reference to the fifth aspect of the invention.

According to a seventh aspect, the present invention is a method of making an implantable electrode array, the method comprising:

- (a) supporting a sheet of electrically conductive biocompatible material;
- (b) working the sheet to remove one or more first portions therefrom;
- (c) connecting at least one electrically conducting wire to said punched sheet using a bonding machine; and
- (d) working the sheet to remove one or more second portions therefrom to form two or more discrete relatively conducting regions.

In one embodiment of this aspect, the bonding machine is an automatic bonding machine. In this regard, the automatic bonding machine may be an automatic welding machine capable of performing ultrasonic or resistance welding.

Preferably, the sheet is no greater than around 200 microns thick.

Preferably, the working of the sheet in step (b) comprising punching the sheet.

Preferably, a portion of each wire is located distal said conducting regions to a common sacrificial member.

Brief Description of the Drawings

30

By way of example only, preferred embodiments of the invention are now described with reference to the accompanying drawings, in which;

Fig. 1 depicts the steps of one embodiment of a method of forming an antenna connected to a feedthrough of a housing according to the present invention;

35

Fig. 2 depicts a wire path template for forming a non-linear wire path according to the present invention;

Fig. 3 depicts a wire having a portion having a non-linear path formed using the
5 template of Fig. 2;

Fig. 4 is a flow chart depicting at least some of the steps of one embodiment of the method of forming an electrode array according to the present invention;

10 Figs. 5a and 5b are a plan and perspective view of an electrode array formed in a platinum sheet;

Fig. 6 depicts the electrode array of Fig. 5b following the welding of wires thereto;

15

Fig. 7 depicts the electrode array of Fig. 6 following a further working step; and

Fig. 8 depicts another embodiment of set of electrodes with wires that are welded thereto extending away therefrom.

20

Preferred Mode of Carrying out the Invention

Fig. 1 depicts some of the steps of a method according to the present invention, depicted generally as 10, for forming an antenna and feedthrough assembly that is
25 suitable for use in a tissue-stimulating device, such as a cochlear implant.

As depicted in Fig. 1a, a feedthrough member 11 and an antenna template 12 are mounted to a workspace member 13. The relative position of the member 11 and template 12 are based on the desired dimensions of the antenna to be formed.

30

In the depicted embodiment, the feedthrough member 11 is mountable in a wall or chassis of a housing 14 and comprises a first portion 15 and a second portion 16. Both of the portions 15,16 have a plurality of conductive posts extending through an electrically insulating block that hermetically seals the housing 14. In the depicted
35 embodiment, the feedthrough member 11 is usable for both the wires feeding back

from the electrodes (not depicted) of an intracochlear array and the wire or wires that will comprise the antenna coil.

In Fig. 1b, a wire bonder 17 is used to connect an end of the antenna wire 18 to a
5 conductive post of the second portion 16 of the feedthrough member 11. The use of wire bonding enables both a mechanical and electrical connection to be achieved in a single operation.

The wire bonder 17 is then used to wind the wire 18 around the template 12 to
10 form the antenna. As depicted in Fig. 1c, the wire 18 is wound around the template 12 to form the antenna coil before then bonding the other end of the wire 18 to the first portion 15 of the feedthrough member 11 (as depicted in Fig. 1d). In the depicted embodiment, the antenna template 12 is cylindrical. It will be appreciated that other shapes might be suitable and could be utilised to form the windings of the antenna.

15

The wire 18 can be coated with an electrically insulating material, such as a polymer material such as parylene. A small area of the insulating material is removed at the end of the wire prior to the respective bondings to the feedthrough member 11. In the depicted embodiment, the wire 18 is formed from platinum or a platinum/iridium
20 alloy and is circular in cross-section. Other shapes of wire are envisaged, including wires that are oval in cross-section or flat, ribbon-like.

Fig. 2 depicts a method of forming a non-linear path of at least a portion of an electrically conducting wire, such as a wire extending from the feedthrough member 11
25 to one or more implantable electrodes (not shown).

In this example, the wire path template comprises a series of appropriately spaced posts 21 about which a wire 22 can be wound by a wire bonder 17. It is envisaged that the posts 21 would be mounted to a workspace member. In the depicted
30 embodiment, an end of the wire is firstly bonded at a first location 23. Location 23 can be envisaged in one embodiment to be a feedthrough member, such as feedthrough member 11 depicted in Figs. 1a-1d, with the formed non-linear wire being one of the wires 19 depicted in Fig. 1 that extends to one or more electrodes.

35 Once the wire 22 has been wound between the posts, the wire can be removed from the workspace or remain in the workspace for further processing as required.

Such further processing might include bonding of one or more electrodes to the wire and/or encapsulation of the wire in an appropriate encapsulant, such as a silicone.

As depicted by Fig. 3, more than one wire 22 can be wound through the wire path template to form a multistrand electrically conducting lead.

As is the case for wire 18 depicted in Figs. 1a-1d, the wire 22 is formed from platinum or a platinum/iridium alloy and is circular in cross-section. Other shapes of wire are envisaged, including wires that are oval in cross-section.

The formed non-linear path of at least a portion of the lead serves to assist in ensuring that the lead does not fail, following implantation, due to movement that may occur between the ends of the lead, such as movement that may occur due to body growth of the implantee. The formed non-linear path is also useful in providing strain relief at the feedthrough connections to protect against damage during the manufacturing process.

Further processes according to embodiments of the present invention for the manufacture of an electrode array are depicted in Figs 4-8 of the drawings.

Fig. 4 is a flow chart of an example of some of the steps of a method according to the present invention, depicted generally as 40, for forming an electrode array that is suitable for use as a tissue-stimulating device within the human cochlea.

As depicted, the method 40 comprises a series of steps 41 to 44 which form the electrode array. In the depicted method 40, and with further reference to Fig 5a, a platinum sheet 53 is used as it is a biocompatible material and is a proven material for use in cochlear implants manufactured using traditional techniques. The sheet 53 is in the form of a foil and typically has a thickness of around 50 microns, although this can vary between about 10 and 200 microns.

In step 41 of the depicted method, the platinum sheet 53 is firstly supported in a holder. The method 40 further comprises a step 42 in which an electrode array pattern is formed in the supported platinum sheet 53. In this example, the following step 42 comprises removing portions of the platinum sheet 53 therefrom such that at least the

desired pattern of the electrode array remains. In the example, step 42 comprises a process of using a punch to punch out unwanted portions of the sheet 53.

As depicted in Fig. 5a, the punch can firstly remove rectangular portions 58 of the sheet 53 leaving a plurality of portions that will become the electrodes 55 of the array after later removing the outer portions 53a of the sheet 53 along the dotted lines shown in Fig 5b. In the depicted embodiment, the electrodes 55 formed in the sheet 53 have a size of about $0.4\text{mm}^2 - 0.5\text{mm}^2$. While the electrodes 55 are depicted as rectangular in shape, it will be appreciated that the electrodes could be formed in different shapes by using a punch to remove non-rectangular portions from the sheet. For example, the punch can be adapted to remove bone-shaped portions.

As depicted in Fig. 5b, the step 42 can further comprise a step of deforming the sheet 53 in a third dimension. In Fig. 5b, the electrodes 55 of the sheet have been deformed so as to adopt a curved configuration by being placed in a concave moulding die.

It will be appreciated that in step 42, those portions of the sheet 53 to be removed can be removed by other techniques, such as laser ablation, micro-knifing, milling, or electrode discharge machining to remove the unwanted portions 58 of the sheet 53.

The method 40 further comprises a step 43 of welding electrically conducting wires 56 to the concave faces of the electrodes 55 (see Fig. 6). The wire 56 can be coated with an electrically insulating material, such as a polymer material such as parylene. A small area of the insulating material is removed at the end of the wire prior to the welding step. This welding is performed by an automatic welding machine. Alternatively, this process can be performed using a wire bonding machine. In the depicted embodiment, the wires 56 are formed from platinum or a platinum/iridium alloy and are circular in cross-section. Other shapes of wire are envisaged, including wires that are oval in cross-section, or are foil-like having a width greater than its thickness.

The outer portions 53a of the sheet 53 serve to hold the sheet in the pattern formed during step 42 during subsequent processing steps.

During step 44, the sheet 53 is preferably trimmed to remove the remaining portions 53a of the sheet that are not comprising the desired electrode array 54 (see Fig. 7). In the depicted example, the sheet 53 is trimmed with a knife. In another embodiment, a punch and die can be used to cut the electrode array from the remaining portions of the original sheet 53.

Each of the electrodes 55, and the corresponding welded wires 56, are formed in a manner such that their position with respect to each other is predetermined and kept constant throughout the process and in the final product.

To maintain this, step 43 can include a step where the proximal ends 57 of each of the wires are welded to a sacrificial plate 61 (see Figs. 6 and 7). It will be appreciated that the connection to the plate 61 could be made at a location away from the proximal end 57 of the wire 56. In this case, however, it is envisaged that the wire 57 would then be trimmed at the location of the weld.

It will be appreciated that each of the wires 56 can be individually welded to their respective electrodes 55 and the sacrificial plate 61. It is, however, preferred that the wires 56 be welded at least substantially simultaneously, at one or both locations, by the automatic welding machine.

As depicted in Figs. 6 and 7, the proximal ends 57 of the wires 56 can be aligned transversely along the sacrificial plate 61. As such, when there are a plurality of electrodes 55 disposed in a longitudinal array and the same number of wires 56 extending therefrom, the wire 56 extending from the electrode 55 that is most distal the sacrificial plate 61 can be at, near or closer to one end of the plate 61, the wire 56 from the next most distal electrode 55 beside it, and so on until each of the wires 56 are electrically connected to the sacrificial plate 61.

This ordering of the connection of the wires 56 to the sacrificial plate 61 results in there being no need to retest which wire 56 is connected to which conductive electrode 55 at a later date in the manufacturing process. Instead, it is possible by noting the location of the weld of the wire 56 to the sacrificial plate 61 to determine which electrode 55 that wire 56 is extending from.

The sacrificial plate 61 as its name implies is adapted to be sacrificed when the electrode array is ready to be electrically connected to a feedthrough device that provides electrical connection through the wall of an implantable component, such as a receiver/stimulator unit of a cochlear implant. For example, the wires 56 can simply be
5 cut from the plate 61 when the wires 56 are to be welded to the feedthrough.

It will be appreciated that a number of electrode sets with corresponding sacrificial plates as depicted in Figs. 6 and 7 could be formed and stacked or laminated together and appropriately encapsulated to form a single tissue stimulating electrode
10 assembly. One example of such an assembly is depicted by Fig. 8. In this embodiment, the electrodes 55 are, however, still planar despite the wires 56 having been welded thereto.

In the case where the electrodes are still planar and as is described in
15 International Publication No WO 02/089907, once the stack is formed, the hitherto at least substantially planar electrodes 55 can then be deformed so as to at least partially extend in a third dimension. In one embodiment, each of the electrodes is curved out of the plane of the wires 56 for each set of electrodes. The curvature can be substantially semi-circular. A mandrel can be used to form the curvature in the electrodes.

20

Once the electrodes 55 have been deformed to have a substantially semi-circular curvature, each of the electrodes 55 can be further folded about a longitudinal axis of the array. This folding of the electrodes 55 serves to bend the electrodes around the wires 56 of the array. The electrodes are preferably folded together and define a lumen
25 that extends through the array.

The lumen can act as a substance delivery means for delivering a bio-active substance to the implant site following implantation. Alternatively or additionally, the lumen can receive a stylet to assist in insertion and placement of the array in the
30 cochlea.

Embodiments of the present invention can be advantageously applied to make an entire assembly of components for an implantable medical device, such as a cochlear implant. For example, a novel "skeleton" of various conductive components
35 can be created within a single work procedure. A subsequent work procedure can then encapsulate the entire skeleton, or at least two components of the entire device.

This rearrangement of the work process steps, where the encapsulation is made in a single step, using a single curing system, helps to improve the integrity of the seal to prevent fluid ingress. This is especially important in implantable medical devices to reduce the risk of malfunction and infection. Traditionally, each one of the various components had been individually encapsulated, before being connected together.

The encapsulation step involves placing the components in a mould, which is then filled with a biocompatible silicone material. Silastic MDX 4-4210 is an example of one suitable silicone. In the case of the electrode array, the silicon forms an electrode carrier member, although the electrodes are preferably positioned in the mould so as to not be coated with the silicone.

It will be appreciated by persons skilled in the art that numerous variations and/or modifications may be made to the invention as shown in the specific embodiments without departing from the spirit or scope of the invention as broadly described. The present embodiments are, therefore, to be considered in all respects as illustrative and not restrictive.

CLAIMS:

1. A method of forming and connecting an antenna to a feedthrough member of a housing, the method comprising the steps of:
 - 5 positioning the feedthrough member and an antenna template relative to each other;
 - connecting a first portion of at least one electrically conducting wire to said feedthrough member;
 - winding said wire at least once around the antenna template; and
 - 10 connecting a second portion of each wire to said feedthrough member.
2. A method according to claim 1, wherein each of the steps are performed in consecutive order.
- 15 3. A method according to any one of the preceding claims, wherein the step of positioning the feedthrough member and the antenna template relative to each other includes removably mounting the feedthrough member to a workspace member.
4. A method according to claim 3, wherein the antenna template is removably
20 mounted to the workspace member.
5. A method according to any one of claims 1 to 4, wherein the antenna template comprises a cylinder and the wound wire defines a circular locus.
- 25 6. A method according to any one of the preceding claims, wherein the feedthrough member comprises a first portion and a second portion, the first and second portions being mountable or mounted in a chassis or wall of the housing.
7. A method according to claim 6, wherein each of the first or second portions
30 have at least one conductive post extending therethrough.
8. A method according to claim 6 or 7, wherein the step of connecting the first portion of each wire to the feedthrough member comprises connecting the wire to the first portion of the feedthrough member, and the step of connecting a second portion of
35 each wire to the feedthrough member comprises connecting the wire to the second portion of the feedthrough member.

9. A method according to claim 8, wherein the wire is connected to the feedthrough member using a wire bonder.
- 5 10. A method according to any one of the preceding claims, wherein the first portion of the wire comprises an end of the wire.
11. A method according to any one of the preceding claims, wherein the second portion of the wire comprises a location along the wire that is distal from the first
10 portion.
12. A method according to any one of the preceding claims, wherein more than one wire is connected to the feedthrough member and wound around the antenna template.
- 15 13. A method according to any one of the preceding claims, wherein each wire is wound around the antenna template twice.
14. A method according to any one of the preceding claims, wherein the wire is formed from a biocompatible electrically conductive material.
- 20 15. A method according to any one of the preceding claims, wherein the wire is coated with an electrically insulating material.
16. A method according to any one of the preceding claims, wherein following
25 completion of winding each wire and connecting the first and second portion of each wire to the feedthrough member, the formed antenna and the feedthrough member are removed from the workspace member.
17. A method according to claim 16, further comprising the step of encapsulating
30 the housing, feedthrough member and antenna in an electrically insulating material.
18. An antenna and feedthrough member assembly as formed by the method of any one of the preceding claims.
- 35 19. An antenna and feedthrough member assembly according to claim 18, wherein the antenna is a receiver antenna.

20. An antenna and feedthrough member assembly according to claim 18 or 19, wherein the assembly is suitable for use in tissue-stimulating or sensor applications.
- 5 21. A method of forming a non-linear path of at least a portion of at least one electrically conducting wire extending between a first location and a second location, the method comprising the steps of:
- forming a wire path template defining a non-linear path;
winding said wire through said template such that said wire adopts said non-
- 10 linear path; and
removing the wire from said template.
22. A method according to claim 47, wherein the wire path template is removably mounted to a workspace member.
- 15 23. A method according to claim 21 or 22, wherein the wire path template is adapted to form an undulating wire path over said portion of the wire.
24. A method according to claim 23, wherein the wire path template comprises a
- 20 series of spaced posts mounted to the workspace member that define the path about which the wire is to be wound.
25. A method according to claim 24, wherein the formed wire path is substantially sinusoidal.
- 25 26. A method according to any one of claims 23 to 25, comprising the additional step of removably mounting a feedthrough member of a housing to the workspace member.
- 30 27. A method according to claim 26, wherein the feedthrough member comprises the first location.
28. A method according to claim 27, comprising the additional step of connecting the wire to the feedthrough member.

29. A method according to claim 28, wherein an end of the wire is connected to the feedthrough member.
30. A method according to claim 29, wherein the wire is connected to the
5 feedthrough member using a wire bonder.
31. A method according to claim 30, wherein the wire bonder also winds the wire through the path of the wire path template.
- 10 32. A method according to any one of claims 21 to 31, wherein the wire is formed from a biocompatible electrically conductive material.
33. A method according to any one of claims 21 to 32, comprising the additional step of coating the wire with an electrically insulating material.
- 15 34. A method according to claim 33, wherein the electrical connection formed between the wire and the feedthrough member is performed through the insulating layer.
- 20 35. A method according to claim 28, wherein following electrical connection to the feedthrough member, the wire undergoes a coating step wherein the wire is encapsulated in an electrically insulating material.
- 25 36. A method according to claim 35, wherein the coating step comprises passing the wire through a parylene coater so as to coat at least parts of the wire with a suitable layer of parylene.
37. A method according to claim 36, wherein at least some parts of the feedthrough member are masked to prevent their coating with parylene.
- 30 38. A method according to any one of claims 21 to 37, wherein the method further includes the step of encapsulating the feedthrough member and at least some of the wire in an electrically insulating material.
- 35 39. A method according to claim 38, comprising the additional steps of washing and drying the feedthrough member and the wire to render it suitable for implantation.

40. A wire having a portion thereof defining a non-linear path when formed by the method as defined in any one of claims 21 to 39.
- 5 41. A wire according to claim 40 for use in an implantable tissue-stimulating device.
42. A wire according to claim 41, wherein the implantable tissue-stimulating device is a cochlear electrode assembly.
- 10 43. A method of forming a device comprised of a predetermined pattern of at least two relatively electrically conductive regions, the method comprising the steps of:
working a sheet of electrically conductive material to remove predetermined portions therefrom to form said two or more discrete relatively conducting regions;
connecting at least one electrically conducting wire to at least one of said at least
15 two or more relatively conducting regions; and
connecting a portion of each wire located distal said conducting regions to a common sacrificial member.
44. A method according to claim 43, wherein the step of working the sheet includes
20 a step of punching the predetermined portions out of the sheet of electrically conductive material.
45. A method according to claim 44, wherein the predetermined portions punched
out of the sheet are removed and separated from the sheet.
25
46. A method according to claim 43, wherein the step of working the sheet includes a step of slicing or cutting the predetermined portions out of the sheet of electrically conductive material.
- 30 47. A method according to claim 43, wherein the step of working the sheet comprises a process of using electrical discharge machining (EDM) or spark erosion to remove said predetermined portions out of the sheet.
48. A method according to claim 43, wherein the step of connecting each wire to the
35 corresponding relatively conducting regions comprises a step of welding each wire to a respective relatively conducting region.

49. A method according to claim 48, wherein a distal end of each wire is welded to the conducting region.
- 5 50. A method according to claim 43, wherein the step of connecting each wire to the sacrificial member comprises a step of welding each wire to the sacrificial member.
51. A method according to claim 50, wherein a proximal end of each wire is welded to the sacrificial member.
- 10 52. A method according to claim 50, wherein the sacrificial member is in the form of a plate.
53. A method according to claim 52, wherein the plate is formed from a suitable
15 metal to allow welding of the distal ends of the wires to the plate.
54. A method according to any one of claims 43 to 53, wherein each of the wires are individually welded to their respective conductive region and the sacrificial member.
- 20 55. A method according to claim 54, wherein an automatic welding machine is used to weld each wire to the conductive regions and the sacrificial member.
56. A method according to claim 55, wherein each wire is welded to the sacrificial
25 member in a manner that allows ready identification as to which conductive region the wire is extending from.
57. A method according to claim 56, wherein the proximal ends of the wires are aligned transversely along the sacrificial member.
- 30 58. A method according to any one of claims 43 to 57, wherein each wire is formed from a biocompatible electrically conductive material.
59. A method according to claim 58, wherein each wire is coated with an electrically insulating material.

60. A method according to claim 59, wherein the electrical connection formed between the wire and the conductive region and/or the sacrificial member, is performed through the insulating layer.
- 5 61. A method according to claim 48 or 50, wherein following the formation of the electrical connection between the wire and the conductive region and/or the sacrificial member, the device undergoes a coating step wherein at least the wires are encapsulated in an electrically insulative material.
- 10 62. A method according to claim 61, wherein the coating step comprises passing the device through a parylene coater so as to coat at least parts of the device with a suitable layer of parylene.
63. A method according to claim 62, wherein the electrically conductive regions are
15 masked to prevent their coating with parylene.
64. A method according to claim 63, further including a step of encapsulating the device in an electrically insulating material.
- 20 65. A method according to claim 64, wherein the encapsulated device undergoes a further washing and drying step to render it suitable for implantation.
66. A method according to any one of claims 43 to 66, wherein the device is an electrode array for an electrode assembly.
25
67. A method according to claim 66, wherein the electrode assembly is for use as an implantable tissue-stimulating device.

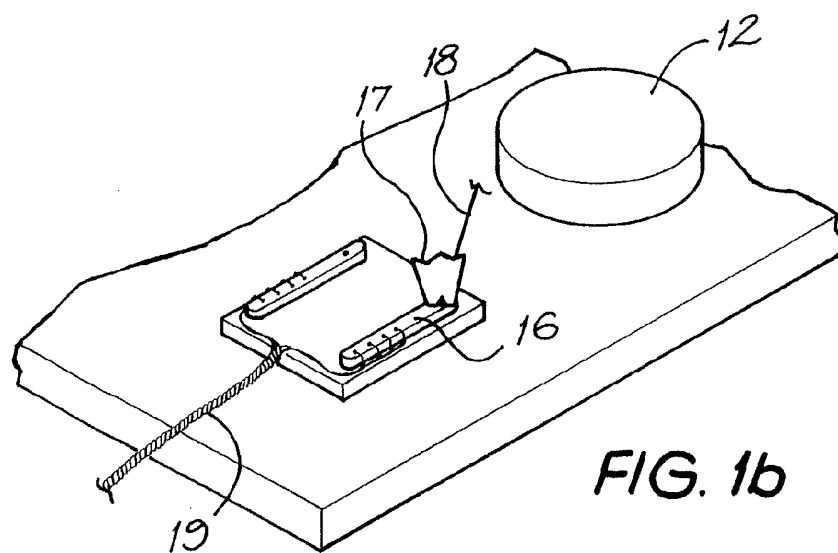
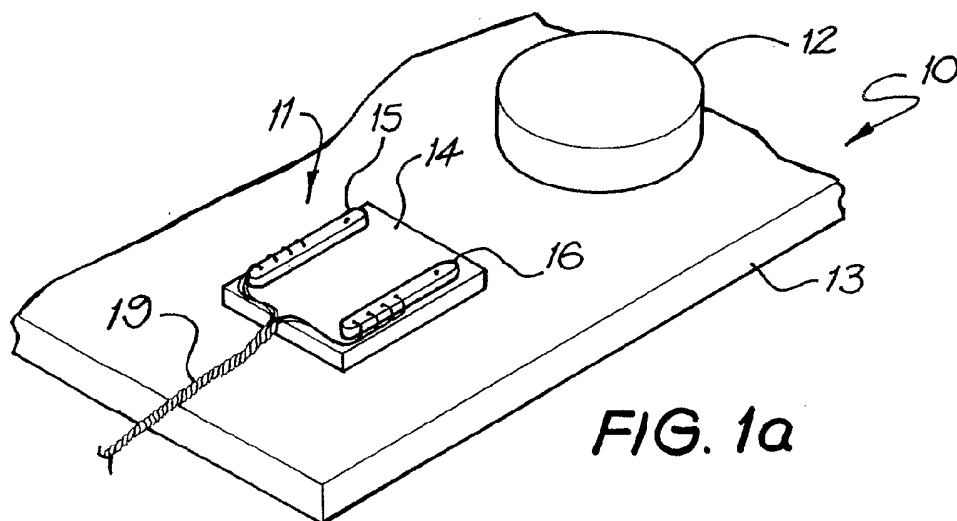

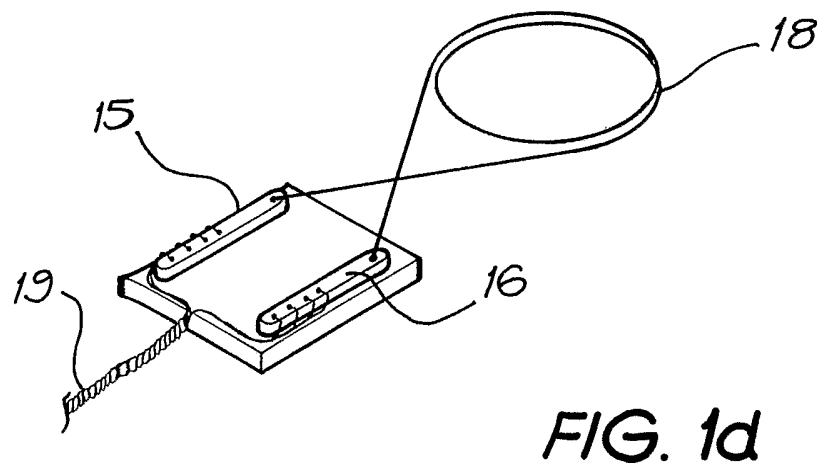
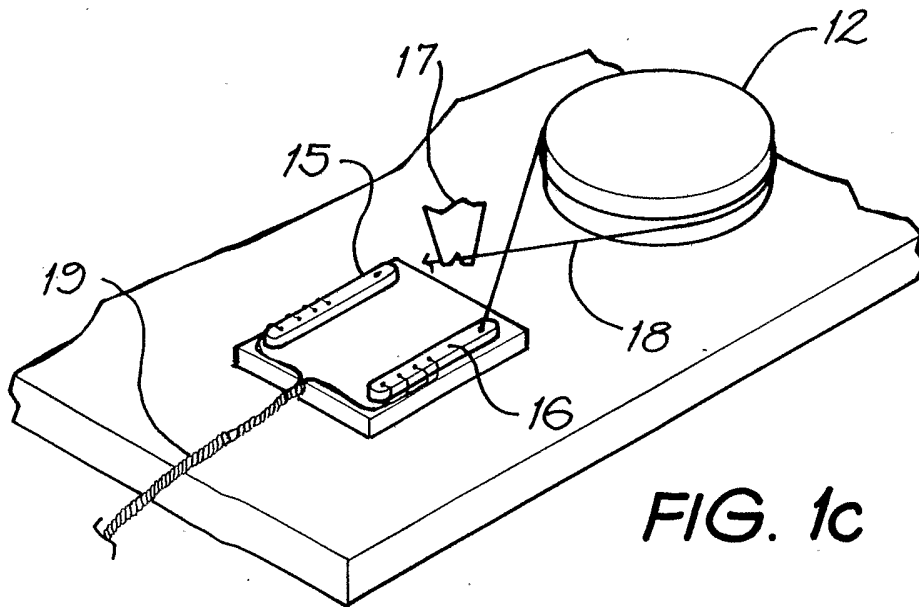

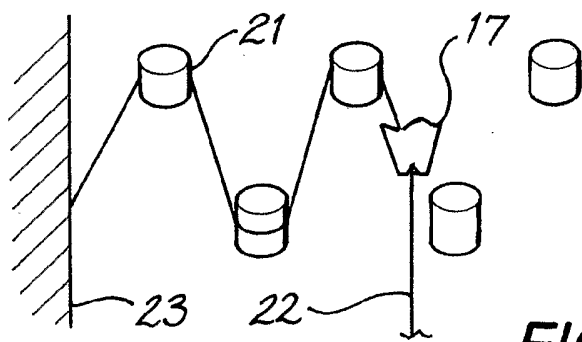

FIG. 2

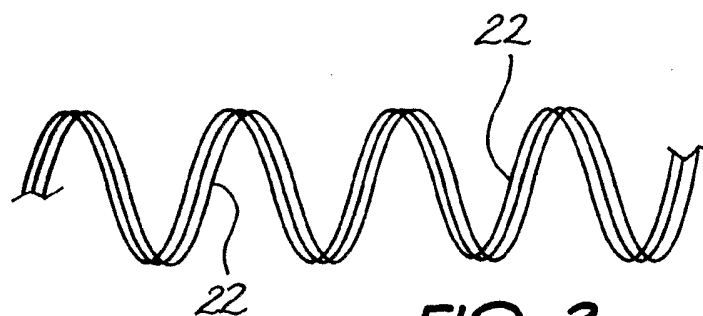

FIG. 3

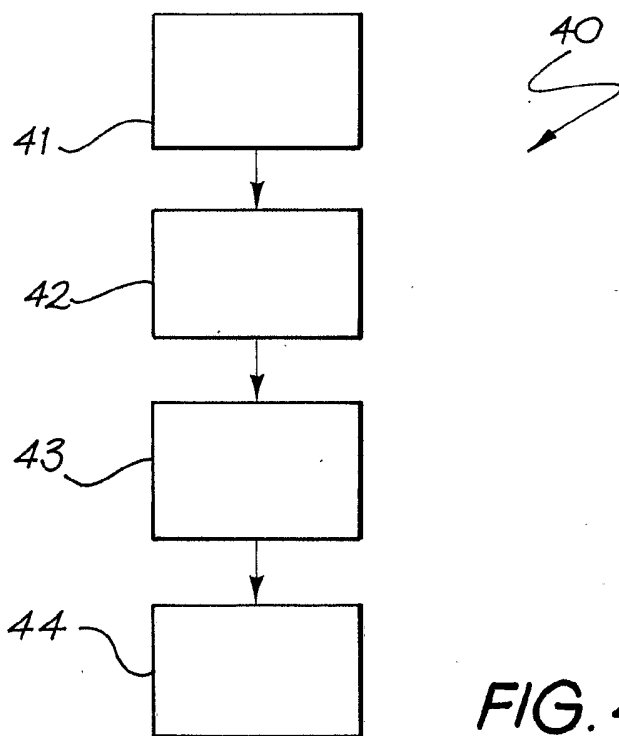

FIG. 4

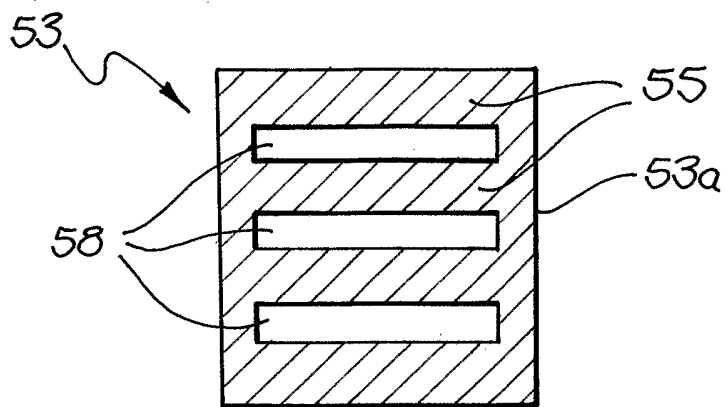

FIG. 5a

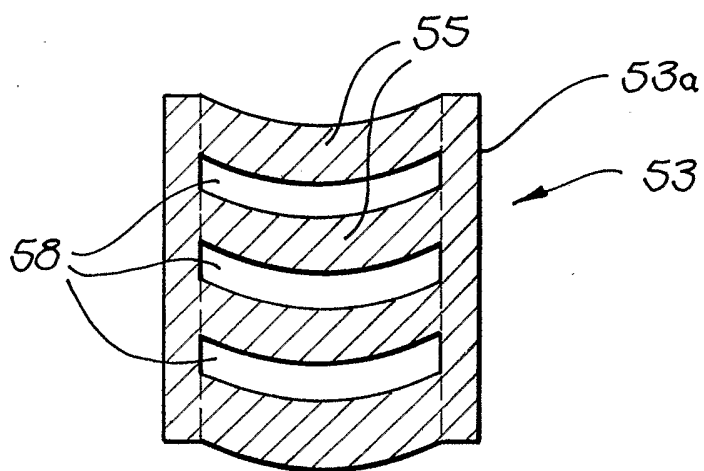

FIG. 5b

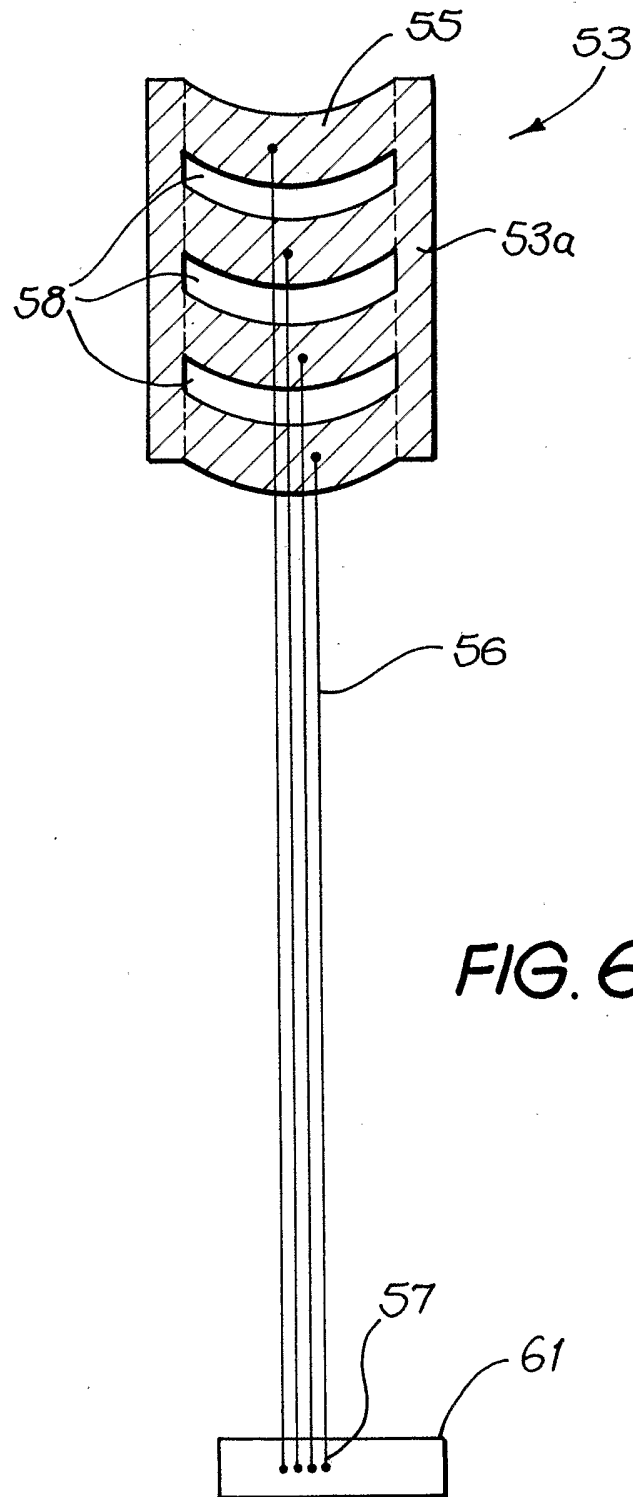

FIG. 6

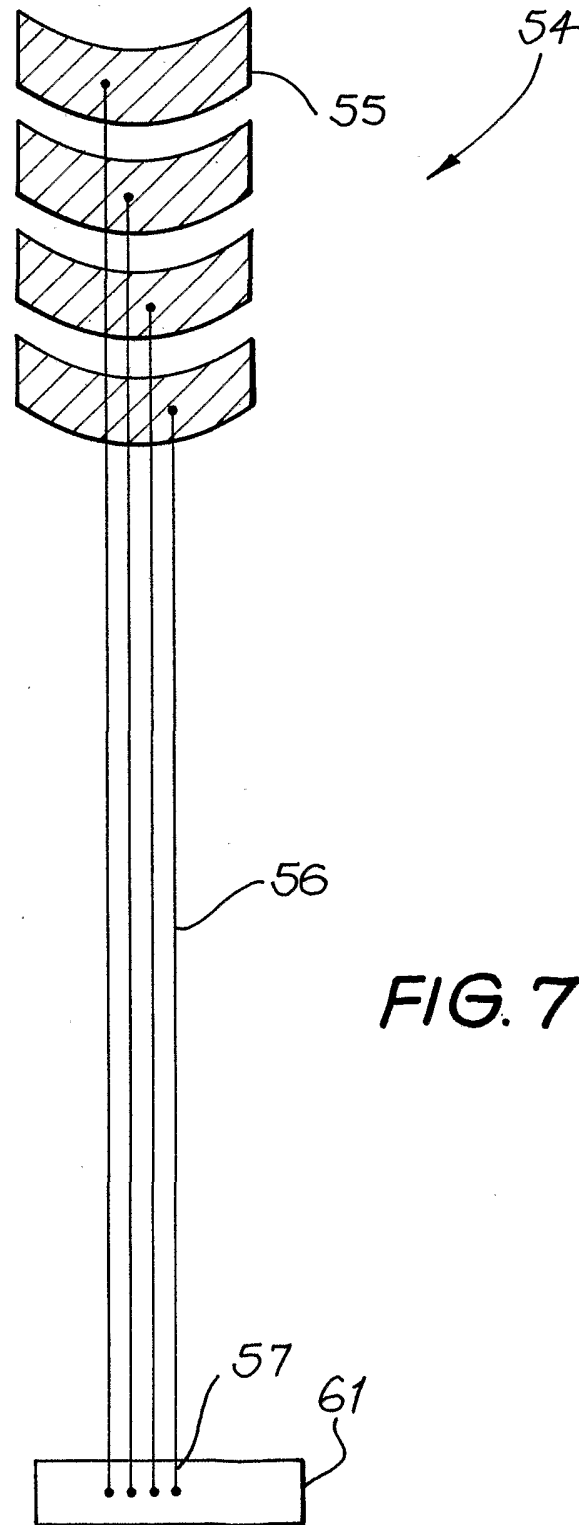

FIG. 7

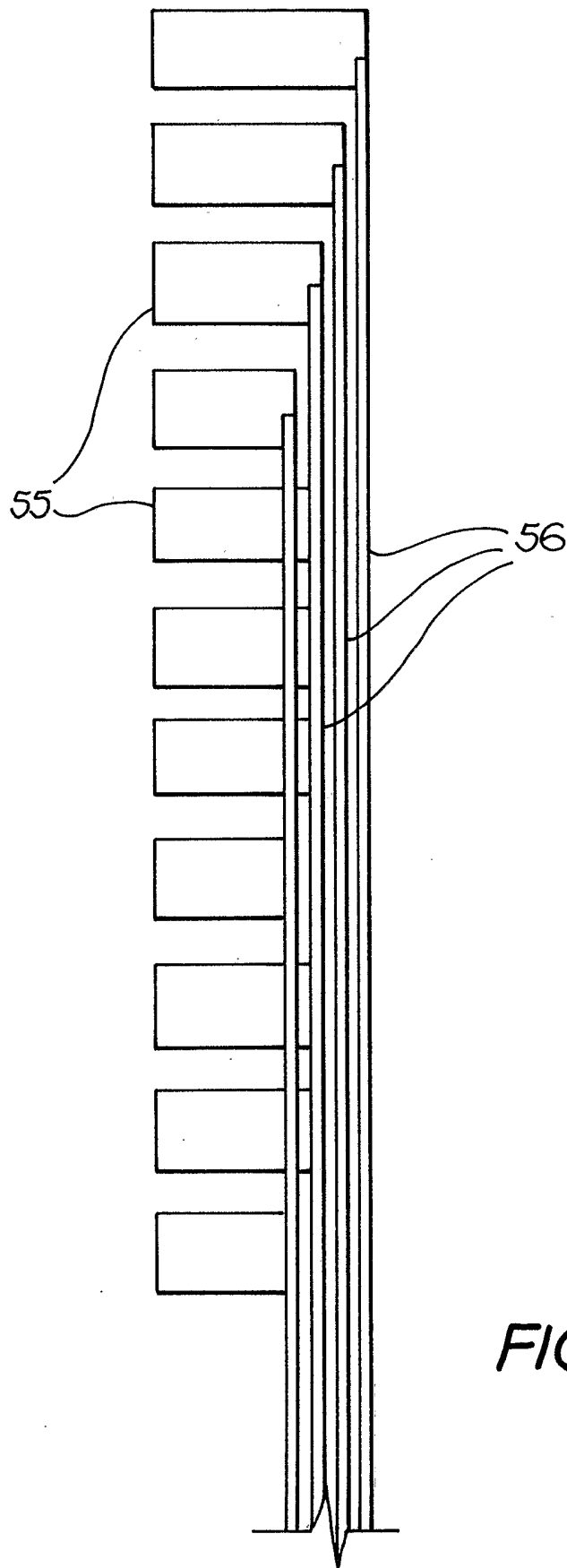

FIG. 8

INTERNATIONAL SEARCH REPORT

International application No.
PCT/AU2004/001726

<p>A. CLASSIFICATION OF SUBJECT MATTER</p> <p>Int. Cl. ⁷: H01Q 1/36, B21F 45/00, H01R 11/09</p> <p>According to International Patent Classification (IPC) or to both national classification and IPC</p>																	
<p>B. FIELDS SEARCHED</p> <p>Minimum documentation searched (classification system followed by classification symbols)</p> <p>Documentation searched other than minimum documentation to the extent that such documents are included in the fields searched</p> <p>Electronic data base consulted during the international search (name of data base and, where practicable, search terms used) dwp1 (method, conductive, connect, wire, winding, antenna, non linear, curve, sheet, region, portion, removal)</p>																	
<p>C. DOCUMENTS CONSIDERED TO BE RELEVANT</p> <table border="1" style="width:100%; border-collapse: collapse;"> <thead> <tr> <th style="width:10%;">Category*</th> <th style="width:70%;">Citation of document, with indication, where appropriate, of the relevant passages</th> <th style="width:20%;">Relevant to claim No.</th> </tr> </thead> <tbody> <tr> <td align="center">X</td> <td>GB 2288028 A (HALLIBURTON COMPANY) 4 October 1995 Page 4, lines 17-29</td> <td align="center">1-20</td> </tr> <tr> <td align="center">X</td> <td>US 6181296 B1 (KULISAN et al.) 30 January 2001 Column 1, line 59 – column 2, line 35, column 4, lines 59-67</td> <td align="center">1-20</td> </tr> <tr> <td align="center">X</td> <td>GB 2356935 A (SCHLUMBERGER HOLDINGS LIMITED) 6 June 2001 The abstract, page 3, lines 19-25</td> <td align="center">1-20</td> </tr> <tr> <td align="center">P,X</td> <td>US 2004/0164923 A1 (AISENBREY) 26 August 2004 The whole document</td> <td align="center">1-20</td> </tr> </tbody> </table>			Category*	Citation of document, with indication, where appropriate, of the relevant passages	Relevant to claim No.	X	GB 2288028 A (HALLIBURTON COMPANY) 4 October 1995 Page 4, lines 17-29	1-20	X	US 6181296 B1 (KULISAN et al.) 30 January 2001 Column 1, line 59 – column 2, line 35, column 4, lines 59-67	1-20	X	GB 2356935 A (SCHLUMBERGER HOLDINGS LIMITED) 6 June 2001 The abstract, page 3, lines 19-25	1-20	P,X	US 2004/0164923 A1 (AISENBREY) 26 August 2004 The whole document	1-20
Category*	Citation of document, with indication, where appropriate, of the relevant passages	Relevant to claim No.															
X	GB 2288028 A (HALLIBURTON COMPANY) 4 October 1995 Page 4, lines 17-29	1-20															
X	US 6181296 B1 (KULISAN et al.) 30 January 2001 Column 1, line 59 – column 2, line 35, column 4, lines 59-67	1-20															
X	GB 2356935 A (SCHLUMBERGER HOLDINGS LIMITED) 6 June 2001 The abstract, page 3, lines 19-25	1-20															
P,X	US 2004/0164923 A1 (AISENBREY) 26 August 2004 The whole document	1-20															
<input checked="" type="checkbox"/> Further documents are listed in the continuation of Box C <input checked="" type="checkbox"/> See patent family annex																	
<p>* Special categories of cited documents:</p> <p>"A" document defining the general state of the art which is not considered to be of particular relevance</p> <p>"E" earlier application or patent but published on or after the international filing date</p> <p>"L" document which may throw doubts on priority claim(s) or which is cited to establish the publication date of another citation or other special reason (as specified)</p> <p>"O" document referring to an oral disclosure, use, exhibition or other means</p> <p>"P" document published prior to the international filing date but later than the priority date claimed</p>	<p>"T" later document published after the international filing date or priority date and not in conflict with the application but cited to understand the principle or theory underlying the invention</p> <p>"X" document of particular relevance; the claimed invention cannot be considered novel or cannot be considered to involve an inventive step when the document is taken alone</p> <p>"Y" document of particular relevance; the claimed invention cannot be considered to involve an inventive step when the document is combined with one or more other such documents, such combination being obvious to a person skilled in the art</p> <p>"&" document member of the same patent family</p>																
<p>Date of the actual completion of the international search 4 March 2005</p>	<p>Date of mailing of the international search report 18 MAR 2005</p>																
<p>Name and mailing address of the ISA/AU AUSTRALIAN PATENT OFFICE PO BOX 200, WODEN ACT 2606, AUSTRALIA E-mail address: pct@ipaaustralia.gov.au Facsimile No. (02) 6285 3929</p>	<p>Authorized officer J. LAW Telephone No : (02) 6283 2179</p>																

INTERNATIONAL SEARCH REPORT

International application No.

PCT/AU2004/001726

C (Continuation). DOCUMENTS CONSIDERED TO BE RELEVANT		
Category*	Citation of document, with indication, where appropriate, of the relevant passages	Relevant to claim No.
A	GB 2166005 A (SANYO ELECTRIC CO LTD et al.) 23 April 1986 The whole document	
X	US 1948875 A (BEITLING) 27 February 1934 The whole document	21-42
X	US 3166104 A (FOLEY, JR. et al.) 19 January 1965 Column 2, lines 7-38	21-42
X	US 4200971 A (SHIMIZU et al.) 6 May 1980 The abstract	21-42
X	US 6446678 B1 (BECHERUCCI et al.) 10 September 2002 The abstract	21-42
X	US 6308744 B1 (BECHERUCCI et al.) 30 October 2001 The abstract	21-42
X	Derwent Abstract Accession No. 87-121639/17, Class V06, SU 1256-122 A (FRUNZE TY AZHELEKTRO) 7 September 1986 The abstract	21-42
X	Derwent Abstract Accession No. 93-376433/47, Class V06, SU 1775803 A1 (KHARK AVIATION INST) 15 November 1992 The abstract	21-42
A	US 6133072 A (FJELSTAD) 17 October 2000 The whole document	

INTERNATIONAL SEARCH REPORT

International application No.
PCT/AU2004/001726

Supplemental Box

(To be used when the space in any of Boxes I to VIII is not sufficient)

Continuation of Box No:

Box III continued

The three inventions are:

1. Claims 1-20 are directed to a method of forming and connecting an antenna to a feedthrough member.
2. Claims 21-42 are directed to a method of forming a non-linear path of a conducting wire extending between a first location and a second location.
3. Claims 43-67 are directed to a method of forming a device comprised of a predetermined pattern of at least two relatively electrically conductive regions.

INTERNATIONAL SEARCH REPORT

Information on patent family members

International application No. PCT/AU2004/001726

This Annex lists the known "A" publication level patent family members relating to the patent documents cited in the above-mentioned international search report. The Australian Patent Office is in no way liable for these particulars which are merely given for the purpose of information.

Patent Document Cited in Search Report	Patent Family Member				
GB 2288028	NO	951225	US	5661402	
US 6181296					
GB 2356935	AU	66529/00	AU	91350/01	BR 0004844
	BR	0105757	CA	2321242	CA 2363534
	GB	2374936	ID	28576	NL 1016727
	NO	20006070	NO	20016222	US 6351127
	US	6380744	US	6557794	US 6566881
	US	6630830	US	2001004212	US 2002008520
	US	2002008521	US	2003155923	
US 20040164923					
GB 2166005	CN	85108084	DE	3536908	FR 2572214
	JP	61097807	JP	61097808	JP 61097809
	JP	61105809	JP	61105810	JP 61105811
	JP	61105812	JP	61124118	JP 61124119
	NL	8502843	US	4860433	
US 1948875					
US 3166104					
US 4200971	DE	2821485	JP	53141402	
US 6446678	CA	2311558	EP	1061634	US 6308744
	US	2002023687			
US 6133072	US	6541867			
Due to data integration issues this family listing may not include 10 digit Australian applications filed since May 2001.					
END OF ANNEX					

INTERNATIONAL SEARCH REPORT

International application No.
PCT/AU2004/001726

Box No. II Observations where certain claims were found unsearchable (Continuation of item 2 of first sheet)

This international search report has not been established in respect of certain claims under Article 17(2)(a) for the following reasons:

1. Claims Nos.:
because they relate to subject matter not required to be searched by this Authority, namely:

2. Claims Nos.:
because they relate to parts of the international application that do not comply with the prescribed requirements to such an extent that no meaningful international search can be carried out, specifically:

3. Claims Nos.:
because they are dependent claims and are not drafted in accordance with the second and third sentences of Rule 6.4(a)

Box No. III Observations where unity of invention is lacking (Continuation of item 3 of first sheet)

This International Searching Authority found multiple inventions in this international application, as follows:

See extra sheet

1. As all required additional search fees were timely paid by the applicant, this international search report covers all searchable claims.
2. As all searchable claims could be searched without effort justifying an additional fee, this Authority did not invite payment of any additional fee.
3. As only some of the required additional search fees were timely paid by the applicant, this international search report covers only those claims for which fees were paid, specifically claims Nos.:

4. No required additional search fees were timely paid by the applicant. Consequently, this international search report is restricted to the invention first mentioned in the claims; it is covered by claims Nos.:

Remark on Protest

- The additional search fees were accompanied by the applicant's protest.
 No protest accompanied the payment of additional search fees.