

(19) World Intellectual Property Organization  
International Bureau



(43) International Publication Date  
10 July 2008 (10.07.2008)

PCT

(10) International Publication Number  
**WO 2008/082931 A1**

(51) International Patent Classification:  
*H02K 7/06* (2006.01) *H02K 7/10* (2006.01)

(74) Agents: **CHAPA, Lawrence J.** et al.; 600 North US Highway 45, Libertyville, Illinois 60048 (US).

(21) International Application Number:  
PCT/US2007/087728

(81) Designated States (unless otherwise indicated, for every kind of national protection available): AE, AG, AL, AM, AT, AU, AZ, BA, BB, BG, BH, BR, BW, BY, BZ, CA, CH, CN, CO, CR, CU, CZ, DE, DK, DM, DO, DZ, EC, EE, EG, ES, FI, GB, GD, GE, GH, GM, GT, HN, HR, HU, ID, IL, IN, IS, JP, KE, KG, KM, KN, KP, KR, KZ, LA, LC, LK, LR, LS, LT, LU, LY, MA, MD, ME, MG, MK, MN, MW, MX, MY, MZ, NA, NG, NI, NO, NZ, OM, PG, PH, PL, PT, RO, RS, RU, SC, SD, SE, SG, SK, SL, SM, SV, SY, TJ, TM, TN, TR, TT, TZ, UA, UG, US, UZ, VC, VN, ZA, ZM, ZW.

(22) International Filing Date:  
17 December 2007 (17.12.2007)

(25) Filing Language: English

(26) Publication Language: English

(30) Priority Data:  
60/882,042 27 December 2006 (27.12.2006) US  
11/956,526 14 December 2007 (14.12.2007) US

(84) Designated States (unless otherwise indicated, for every kind of regional protection available): ARIPO (BW, GH, GM, KE, LS, MW, MZ, NA, SD, SL, SZ, TZ, UG, ZM, ZW), Eurasian (AM, AZ, BY, KG, KZ, MD, RU, TJ, TM), European (AT, BE, BG, CH, CY, CZ, DE, DK, EE, ES, FI, FR, GB, GR, HU, IE, IS, IT, LT, LU, LV, MC, MT, NL, PL, PT, RO, SE, SI, SK, TR), OAPI (BF, BJ, CF, CG, CI, CM, GA, GN, GQ, GW, ML, MR, NE, SN, TD, TG).

(71) Applicant (for all designated States except US): **MOTOROLA, INC.** [US/US]; 1303 East Algonquin Road, Schaumburg, Illinois 60196 (US).

(72) Inventors; and

(75) Inventors/Applicants (for US only): **PAIS, Martin R.** [US/US]; 180 Clover Hill Lane, North Barrington, IL 60010 (US). **CHENG, Shumin** [CA/US]; 158 Royal Oak, Vernon Hills, IL 60061 (US). **SCHMIDT, Detlef** [DE/US]; 1417 Harvard Lane, Schaumburg, IL 60193 (US).

**Published:**  
— with international search report  
— before the expiration of the time limit for amending the claims and to be republished in the event of receipt of amendments

(54) Title: ELECTRIC MOTOR WITH A RETRACTABLE SHAFT

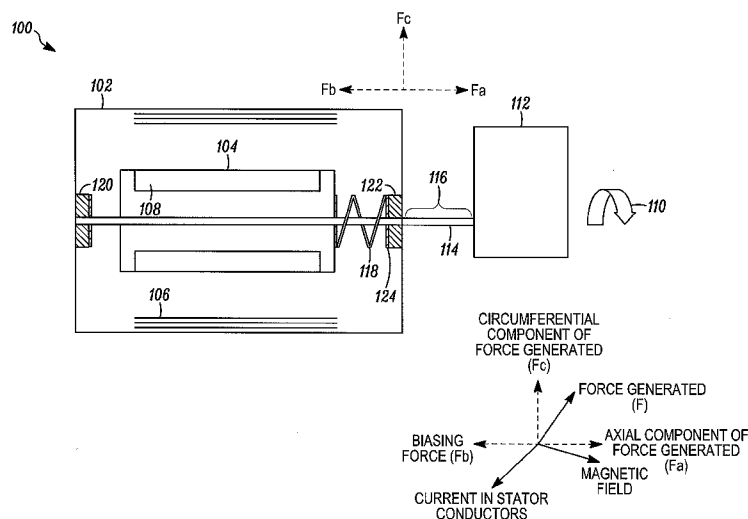

(57) Abstract: An electric motor (100) for controlling the lateral displacement of a shaft (114) connected to a rotor (104) of the electric motor (100) is provided. The electric motor (100) includes one or more stator conductors (106) for carrying a current and one or more permanent magnets (108) to produce a magnetic field (504). The one or more stator conductors (106) interact with the magnetic field (504) when the power is applied, to purposely generate a force with an axial (Fa) and a circumferential component (Fc). The electric motor (100) includes the shaft (114) that travels along a rotor axis (106) in an axial direction when the power is applied, under an action of the axial component of the force. However, when the power is removed, the shaft (114) retracts under the action of a biasing force from a tension device (118).

WO 2008/082931 A1

## ELECTRIC MOTOR WITH A RETRACTABLE SHAFT

### FIELD OF THE INVENTION

The present invention generally relates to an electric motor, and more  
5 specifically, to an electric motor with a retractable shaft.

### BACKGROUND OF THE INVENTION

A typical electric motor includes a stator and a rotor. The stator is the  
stationary section of the electric motor, whereas the rotor is its rotating section. The  
10 rotor typically provides a rotational motion to a load connected to it.

In at least one known application of the electric motor, it is used as part of a  
vibrator assembly. In a vibrator assembly, the rotor of the electric motor has an  
unbalanced cantilevered mass connected to the rotor of the electric motor through a  
shaft. The vibrator assembly is often used in devices, to provide haptic feedback to  
15 the user with a vibratory force. Currently, many electronic devices, for example,  
many mobile phones and pagers, utilize the vibrator assembly to produce vibration for  
at least some forms of a call alert. The electric motor gets energized and the  
unbalanced mass attached to it starts rotating as soon as the motor detects a signal  
associated with an incoming call, which provides a vibratory motion to the electronic  
20 device. When being rotated, the mass is often extended away from the body of the  
motor along the length of the shaft in a cantilevered configuration in order to  
minimize any friction and/or interference between the motor and the mass.

However, in certain situations, when the electronic device is dropped  
accidentally, there is a risk of the shaft being bent due to the weight and the extended  
25 position of the cantilevered mass attached to it. In a still worse scenario, the shaft can  
be completely disconnected from the electric motor or the weight may get knocked  
off from the shaft, thereby damaging the electronic device and/or affecting the  
device's ability to produce future vibrational forces.

In an attempt to avoid the above noted bending or deformation, some designs  
30 have attempted to use a high-grade material with a higher tensile strength from which  
the shaft is manufactured. However, various tests conducted on shafts composed of

different materials have shown that the shafts composed of lower tensile strength materials generally have a higher fracture resilience than the shafts composed of higher tensile strength materials under at least some conditions of impact. In other words, while some harder materials had a greater resistance to bending, they often  
5 showed a greater propensity to crack or break under the same circumstances. Furthermore, it has also been demonstrated that under at least some expected usage conditions that even many of the higher-grade materials including at least some higher tensile strength steels still may not be able to withstand the maximum anticipated stresses likely to be encountered when the device is dropped. Moreover, a higher-  
10 grade material can also increase the cost of the shaft and consequently the cost of the electric motor.

In light of the above-mentioned facts, there exists a need for a method and system for preventing and or reducing the possibility of the shaft of an electric motor from getting damaged or bent in the event an electronic device comprising the electric  
15 motor is dropped.

### SUMMARY OF THE INVENTION

In at least one embodiment of the present invention, an electric motor for use  
20 in a device is provided. The electric motor includes a stator, a rotor, and a shaft connected to the rotor. The stator includes one or more stator conductors to carry the current when power is applied. The rotor includes one or more magnets to produce a magnetic field. When power is applied, the one or more stator conductors interact with the magnetic field to purposely generate a force with an axial and a  
25 circumferential component. Due to the action of the axial component of the force, the shaft travels along a rotor axis in an axial direction from a rest position. When the power is removed, the axial component of the force is no longer present. Therefore, the shaft retracts under the action of the biasing force provided by a tension device.

In another embodiment of the present invention, a vibrator assembly is  
30 provided. The vibrator assembly includes a motor. The motor includes a stator, a rotor, a shaft connected to the rotor, and an unbalanced mass coupled to the shaft.

The stator includes one or more stator conductors to carry current when power is applied. The rotor includes one or more magnets to produce a magnetic field. When power is applied, the one or more stator conductors interact with the magnetic field to produce a force with an axial and a circumferential component. Due to the axial  
5 component of the force, the shaft travels along a rotor axis in an axial direction. Further, the shaft rotates under the action of the circumferential component of the force. Moreover, when power is removed, and the axial component of the force is no longer present, the shaft retracts under the action of a biasing force from a tension device. The unbalanced mass rotates under the action of the circumferential  
10 component of the force on the rotor when power is applied.

In a another embodiment of the present invention, a method for controlling lateral positioning of a shaft within an electric motor during the operation of the electric motor is provided. The electric motor includes a stator, a rotor and a shaft connected to the rotor. The rotor is biased in an axial direction towards a parked  
15 position by means of a tension device. When power is applied to the electric motor, the magnetic field produced by one or more magnets of the stator interact with one or more current-carrying stator conductors, thereby purposely generating a force with an axial and a circumferential component. The axial component of the purposely-generated force extends the shaft in an axial direction against the biasing force  
20 provided by the tension device.

These and other features, as well as the advantages of this invention, are evident from the following description of one or more embodiments of this invention, with reference to the accompanying figures.

### BRIEF DESCRIPTION OF THE FIGURES

The present invention is illustrated by way of example, and not limitation, in the accompanying figures, in which like references indicate similar elements, and in which:

5           **FIG. 1** illustrates an exemplary electric motor when power is applied to the electric motor, in accordance with at least one embodiment of the present invention;

**FIG. 2** illustrates an exemplary electric motor when power is removed therefrom, in accordance with at least one embodiment of the present invention;

10           **FIG. 3** illustrates an exemplary electric motor when power is applied thereto, in accordance with another embodiment of the present invention;

**FIG. 4** illustrates an exemplary electric motor when power is removed therefrom, in accordance with another embodiment of the present invention;

15           **FIG. 5** illustrates an exemplary electric motor showing the relative arrangement and interaction of one or more stator conductors with a magnetic field in the electric motor, in accordance with at least one embodiment of the present invention;

**FIG. 6** illustrates an exemplary electric motor showing the relative arrangement and interaction of one or more stator conductors with a magnetic field in the electric motor, in accordance with another embodiment of the present invention;

20           **FIG. 7** illustrates an exemplary electric motor showing the relative arrangement and interaction of one or more stator conductors with a magnetic field in the electric motor, in accordance with yet another embodiment of the present invention;

25           **FIG. 8** illustrates an exemplary electric motor showing the relative arrangement and interaction of one or more stator conductors with a magnetic field in the electric motor, in accordance with yet a still further embodiment of the present invention;

30           **FIGS. 9A and 9B** illustrate an exemplary relative arrangement and interaction between and corresponding alignment of the one or more stator conductors and the magnetic field produced by one or more magnets in the electric motor, in accordance

with the exemplary electric motor illustrated in FIG. 8, when current is either present or not present in the one or more stator conductors;

**FIG. 10** is a flow diagram illustrating a method for controlling lateral positioning of a shaft within an electric motor during the operation of the electric motor, in accordance with various embodiments of the present invention; and

**FIG. 11** illustrates a device where various embodiments of the present invention can be applied.

Skilled artisans will appreciate that elements in the figures are illustrated for simplicity and clarity and have not necessarily been drawn to scale. For example, the dimensions of some of the elements in the figures may be exaggerated, relative to other elements, to help in improving an understanding of embodiments of the present invention.

#### DETAILED DESCRIPTION

Before describing in detail the particular electric motor, in accordance with various embodiments of the present invention, it should be observed that the present invention resides primarily in combinations of the apparatus components of the electric motor, related to lateral displacement of the shaft within the electric motor. Accordingly, the apparatus components and method steps have been represented, where appropriate, by conventional symbols in the drawings, showing only those specific details that are pertinent for an understanding of the present invention, so as not to obscure the disclosure with details that will be readily apparent to those with ordinary skill in the art, having the benefit of the description herein.

In this document, relational terms such as 'first' and 'second', and the like, may be used solely to distinguish one entity from another entity, without necessarily requiring or implying any actual such relationship or order between such entities. The terms "comprises," "comprising," or any other variation thereof, are intended to cover a non-exclusive inclusion, such that a process, method, article or apparatus that comprises a list of elements does not include only those elements but may include other elements not expressly listed or inherent to such a process, method, article or apparatus. An element preceded by "comprises ... a" does not, without more

constraints, preclude the existence of additional identical elements in the process, method, article or apparatus that comprises the element. The term ‘another’, as used herein, is defined as at least a second or more. The term ‘including’ as used herein, is defined as comprising.

5           **FIG. 1** illustrates an exemplary electric motor **100** when power is applied to the electric motor **100**, in accordance with at least one embodiment of the present invention. The electric motor **100** is housed in a motor-housing **102**. Examples of the electric motor **100** can include, but are not limited to, a Permanent Magnet Direct Current (PMDC) motor and a Switched Reluctance Motor (SRM). The electric motor  
10   **100** includes a stator and a rotor **104**. The stator is an external section of the electric motor **100** and is stationary. The stator can include one or more stator conductors for carrying current, for example, a current-carrying stator conductor **106**. The rotor **104** is the rotating section of the electric motor **100** and includes one or more permanent magnets **108** for producing a magnetic field.

15           When power is applied to the electric motor **100**, current flows in the one or more stator conductors **106**. The current-carrying stator conductors **106** interact with the magnetic field produced by the one or more permanent magnets **108** to purposely generate a force known as the Lorentz Force. According to the Lorentz Force law, when a magnetic field is applied, perpendicular to a current-carrying conductor, a  
20   force is generated that is perpendicular to the current-carrying conductor and the magnetic field. The generated force is typically purely circumferential.

          However, when a vector direction of the magnetic field is aligned at an angle other than 90 degrees, relative to the axial direction of the current-carrying stator conductor **106**, the force generated is not purely circumferential. Instead, the  
25   purposely-generated force has an axial as well as a circumferential component. In at least one embodiment of the present invention, the one or more current-carrying stator conductors **106** are not aligned at an angle of 90 degrees to the vector direction of the magnetic field, but are skewed, relative to the rotor axis. An exemplary embodiment incorporating such an arrangement is illustrated and explained in conjunction with

30   **FIG. 5.**

In another embodiment of the present invention, the vector direction of the magnetic field is not perpendicular to the stator conductors **106**, but is skewed, relative to the radial and axial direction of the rotor **104**. It will be apparent to one ordinarily skilled in the art that the radial direction of the rotor **104** can be represented  
5 by a vector that is perpendicular to the axis of the rotor. An exemplary embodiment in accordance with this further embodiment is illustrated and explained in conjunction with **FIG. 6**. In a still further embodiment of the present invention, the one or more current-carrying stator conductors **106** are skewed, relative to the axis of the rotor **104**, and the vector direction of the magnetic field is skewed, relative to the radial  
10 direction of the rotor **104**. An example of the still further embodiment is illustrated and explained in conjunction with **FIG. 7**.

When the magnetic field is aligned at an angle other than 90 degrees to the one or more current-carrying stator conductors **106**, the generated force has a purposeful axial component ( $F_a$ ) in addition to the circumferential component ( $F_c$ ). The  
15 circumferential component of the force rotates the rotor **104** in a direction **110**. The axial component of the force moves the rotor **104** in an axial direction. The axial component of the force so generated can be utilized to move a load **112** attached to the rotor **104** in an axial direction.

The load **112** can be attached to the electric motor **100** through a shaft **114**,  
20 which is coupled to the rotor **104**. In at least one embodiment of the present invention, the rotor **104** and the shaft **114** can be cast in a single piece. Initially, the shaft **114** is at a rest position when power is not applied to the electric motor **100**. When power is applied to the electric motor **100**, the shaft **114** travels along a rotor axis in an axial direction under the influence of the axial component of force ( $F_a$ ).  
25 The load **112** travels with the shaft **114** in the axial direction.

In at least one embodiment of the present invention, the load **112** can be an unbalanced mass. This unbalanced mass travels with the shaft **114** due to the axial component of the force, when power is applied to the electric motor **100**. Further, the unbalanced mass rotates with the rotor and the shaft due to the circumferential  
30 component of the force. The rotation of the unbalanced mass can produce vibration in the device.



When power is removed from the electric motor **100**, the shaft **114** retracts due to a biasing force ( $F_b$ ). The biasing force can be provided by a tension device. In the illustrated embodiment, the tension device can be a spring **118**. Examples of the spring **118** can be a helical spring and a leaf spring. It will be apparent to a person  
5 ordinarily skilled in the art that any device that is capable of providing a biasing force can be used as a tension device.

In the illustrated embodiment, the spring **118** is located co-axially with the shaft **114** between the rotor **104** and the motor-housing **102**. In another embodiment of the present invention, the spring can be located co-axially with the shaft **114** on the  
10 exterior and opposite end of the electric motor **100**, relative to the load **112** between the end of the shaft **114** and the motor-housing **102**. In the illustrated embodiment, the spring is in a more compressed state when power is applied, as shown in **FIG. 3**. Further, when the power is removed, the spring biases the shaft and the attached mass toward a less compressed state, as illustrated in **FIG. 4**.

The electric motor **100** can also include a bearing arrangement, which can be  
15 adapted to support the travel of the shaft **114** in the axial direction, as well as the circumferential direction. The bearing arrangement can include one or more bearings, for example, a bearing **120** and a bearing **122**. Examples of the one or more bearings include, but are not limited to, a ball bearing, a roller-thrust bearing, a ball-thrust  
20 bearing, and a tapered roller-thrust bearing. In the illustrated embodiment, the bearing **122** is located proximate the spring **118** through one or more spacers, such as spacer **124**. The spacer **124** in many instances represents an intermediate element, which can be used to reduce friction between elements. In at least some instances the spacer can include one or more fiber washers having a lubricant applied thereto. In  
25 some instances, the width of the spacer can also be used to adjust the relative spacing of elements and account for certain tolerances during manufacture, as well as ensure proper positioning of the stator relative to the rotor during instances in which power is alternatively applied and/or is removed. The spring **118**, the bearing **122** and the spacer **124** can be coaxially located in the electric motor **100**.

**FIG. 2** illustrates an exemplary electric motor **100** when power is removed  
30 from the electric motor **100**, in accordance with at least one embodiment of the

present invention. When power is removed from the electric motor **100**, the current in the one or more stator conductors **106** is no longer present. Therefore, the purposely-generated force resulting from the interaction of a current through the conductor and the magnetic field including the circumferential and the axial component of the force  
5 dissipates. In turn, the shaft **114** retracts to a parked position due to the biasing force of the tension device. In at least one embodiment of the present invention, the tension device is a spring **118**. The spring **118** is in a more compressed state as a result of the portion of the force corresponding to the axial component, when power is applied, as illustrated in **FIG. 1**. However, when the power is removed, the spring **118** is allowed  
10 to return to a less compressed state. Therefore, the spring **118** will generally bias the load **112** towards the motor-housing **102**, and a parked position relative to the motor-housing **102**, in absence of an application of any countervailing forces.

In at least one embodiment of the present invention, the spring **118** can be located co-axially with the shaft **114** between the rotor **104** and the motor-housing  
15 **102**, as shown in **FIG. 1** and **FIG. 2**. In another embodiment of the present invention, the spring can be located co-axially with the shaft **114**, on the exterior and opposite ends of the electric motor **100**, relative to the load **112** between the end of the shaft **114** and the motor-housing **102**, as shown in **FIG. 3** and **FIG. 4**.

**FIG. 3** illustrates an exemplary electric motor **100** when power is applied to  
20 the electric motor **100**, in accordance with another embodiment of the present invention. The electric motor **100** includes the load **112** that is coupled to the rotor **104** of the electric motor **100** through the shaft **114**. When the power is not applied, the load **112** is biased towards the motor-housing **102** due to a tension device, for example, a spring **302**. In the illustrated embodiment, the spring **302** can be located  
25 co-axially with the shaft **114** on the exterior and opposite end of the electric motor **100**, relative to the load **112** between the end of the shaft **114** and the motor-housing **102**. Moreover, the spring **302** can also be located proximate to one or more bearings, for example, a bearing **304**, through one or more spacers, for example, a spacer **306**. The spacer **306** can help ensure proper positioning of the various elements such as the  
30 rotor **104** and the motor housing **102**. The spring **302**, the bearing **304**, and the spacer **306** can be coaxially located in the electric motor **100**.

When power is applied, a force is generated due to the interaction of the current-carrying stator conductor **106** with a magnetic field produced by one or more permanent magnets **108**. The generated force has an axial and a circumferential component. The axial component of the generated force can push the shaft **114** in an axial direction against the biasing force of the spring **302**, and correspondingly the mass **112** attached proximate the end of the shaft toward a position that is a safe distance away from the motor housing **102** in order to allow for a more unobstructed rotation of the mass **112**.

**FIG. 4** illustrates an exemplary electric motor **100** when power is removed from the electric motor **100**, in accordance with another embodiment of the present invention. When the power is removed, the current in the stator conductors **106** is reduced to zero. As a result, the force which is generated due to the interaction of the current-carrying stator conductor **106** and the magnetic field is similarly dissipated. In the absence of the generated force, the load **112** attached to the electric motor **100** is allowed to retract due to a biasing force of the spring **302** toward a parked position. The parked position helps to reduce the amount of bending moment produced by the mass on the shaft, in the event that the motor with the attached mass were to be dropped. The retraction of the shaft serves to move the mass closer to the bearing supports, which in turn reduces the amount of torque produced by the mass, when an externally applied jarring force, such as the kind of force felt from impacting a relatively unyielding and/or static surface after a fall.

**FIG. 5** illustrates an exemplary electric motor **100**, showing the interaction of one or more stator conductors **502** with a magnetic field **504** in the electric motor **100**, in accordance with at least one embodiment of the present invention. The electric motor **100** includes the one or more stator conductors **502** and one or more permanent magnets **108** for producing the magnetic field **504**. In at least one embodiment of the present invention, the one or more stator conductors **502** are skewed, relative to a rotor axis **506**. The vector direction of the magnetic field **504** produced by the one or more permanent magnets **108** can be parallel, relative to the radial direction of the rotor **104**. Since the current-carrying stator conductors **502** are skewed, relative to the rotor axis **506**, the interaction of the magnetic field **504** with the current-carrying

stator conductors **502** generates a force having a more than trivial and/or incidental axial component in addition to the more traditional circumferential component. The axial component of the generated force pushes the shaft **114** along the rotor axis **506** away from the parked position.

5           **FIG. 6** illustrates an exemplary electric motor **100**, showing the interaction of the one or more stator conductors **602** with a magnetic field **604** in the electric motor **100**, in accordance with another embodiment of the present invention. In the illustrated embodiment, the one or more stator conductors **106** are parallel to the rotor axis **506**. Alternatively, the vector direction of the magnetic field **604** produced by  
10 the one or more permanent magnets **108** is skewed, relative to the radial and axial direction of the rotor **104**. Since the vector direction of the current in the stator conductors **602** is aligned at an angle other than 90 degrees to the vector direction of the magnetic field **604** produced by the permanent magnets **108**, a force is similarly generated having a more than incidental axial component in addition to the  
15 circumferential component. The axial component of the purposely-generated force similarly produces a movement of the rotor **104** in an axial direction.

**FIG. 7** illustrates a still further exemplary electric motor **100**, showing a still further potential interaction of one or more stator conductors **702** with a magnetic field **704** in the electric motor **100**, in accordance with yet another embodiment of the  
20 present invention. In the present embodiment, the one or more stator conductors **702** are skewed, relative to the rotor axis **506**. Further, the vector direction of the magnetic field **704** produced by one or more permanent magnets **108** is also skewed, relative to the radial and axial direction of the rotor **104**. The interaction of the skewed one or more current-carrying stator conductors **702** with the skewed magnetic  
25 field **704** is similarly arranged such that it generates a force with an axial and a circumferential component. The axial component of the generated force biases the rotor and corresponding permanent magnets **108**, and the shaft **114** and corresponding mass **112** along the rotor axis **506** away from a parked position.

**FIG. 8** illustrates yet a still further exemplary electric motor **100**, showing a  
30 still further potential interaction of one or more stator conductors **802** with a magnetic field induced by one or more magnets **804** in the electric motor **100**. In the present

embodiment, the one or more stator conductors **802** are axially offset, relative to one or more magnets **804** and the corresponding magnetic field. There is a tendency for a current carrying conductor to position itself within a magnetic field at the lowest potential point, which in the illustrated embodiment corresponds to the one or more  
5 current carrying stator conductors **802** being biased toward the center of the magnetic field **806**. Such an alignment requires a relative axial shift between the one or more stator conductors **802** and the one or more magnets **804**, when current is applied and sent through the stator conductors **802**. The centering force is in addition to the circumferential force, which is similarly induced as a result of the interaction between  
10 the one or more current carrying conductors **802** and the magnetic field **804**.

In at least a first instance when current is not applied and sent through the one or more stator conductors **802**, as illustrated in **FIG. 9A**, the axial position of the one or more stator conductors **802** relative to the one or more magnets **804** is generally unbiased. In such an instance the relative axial position will be largely alternatively  
15 influence by other forces being applied to either of the one or more stator conductors **802** or the one or more magnets **804**. At least one such potential source includes a spring **118** or **302** of the type illustrated in **FIGS. 1-4**, which can be arranged and positioned to bias the rotor relative to the stator in a parked and/or retracted position, when the rotor is not being rotated, and the centering force associated with a current  
20 carrying stator conductor **802** in a magnetic field **804** is not present.

In at least a further instance when current is applied and sent through the one or more stator conductors **802**, as illustrated in **FIG. 9B**, the axial position of the one or more stator conductors **802** relative to the one or more magnets **804** is biased toward a more centered position, against the influence of any alternative sources, such  
25 as the above noted spring **118** or **302**. Generally, the strength of the spring force associated with the spring **118** or **302** will be selected such that it is sufficient to bias the rotor toward a parked position in the absence of a countervailing force, but it is readily overcome by the centering force of the current carrying conductor **802** in the presence of the magnetic field **804**. The resulting centering force generally biases the  
30 rotor and corresponding permanent magnets **108**, along with the associated shaft **114** and corresponding mass **112** along the rotor axis **506** away from a parked position.

In this way the mass **112** can be positioned appropriately during the rotation of the same, a distance away from the motor housing **102** to limit the amount of any frictional interaction during times when the motor is actuated to produce a vibrational effect, and the mass can be parked more proximate the motor housing thereby limiting the overall distance **116** that the cantilevered mass **112** is positioned away from the point of support in the motor housing **102**, during times when the motor is not producing a vibrational effect and may be the subject of a jarring force.

**FIG. 10** is a flow diagram illustrating a method **1002** for controlling lateral positioning of a shaft **114** within the electric motor **100** during the operation of the electric motor **100**, in accordance with various embodiments of the present invention. Initially, the rotor **104** is biased **1004** within the electric motor **100** in an axial direction towards a parked position, when the power is not applied to the electric motor **100**. In at least some instances, the rotor **104** is biased towards a parked position through a force applied through the use of a tension device. In at least some instances, the tension device can be the spring **118**. Power is applied **1006** to the electric motor **100**, producing a current in the one or more stator conductors **106**. The current that is produced in the one or more stator conductors **106** interacts with the magnetic field **504** produced by the permanent magnets **108**.

When power is applied to the electric motor **100**, the current starts flowing in the one or more stator conductors **106**. The one or more current-carrying stator conductors **106** interact with the magnetic field produced by the one or more permanent magnets **108**, which is misaligned with one or more stator conductors **106**. In at least some instances, the one or more stator conductors **106** can be skewed, relative to the rotor axis **506**. In other instances, the current-carrying stator conductors **106** are parallel to the rotor axis **506**, and the vector direction of the magnetic field generated by the permanent magnets **108** is skewed, relative to the radial and axial direction of the rotor **104**. In yet another embodiment, the current-carrying stator conductors **106** are skewed, with respect to the rotor axis **506**, and the vector direction of the magnetic field **504** generated by the permanent magnets **108** is skewed, relative to the radial and axial direction of the rotor **104**.

A force is generated, based on the interaction of the current-carrying one or more stator conductors **106** with the magnetic field. The purposely-generated force has an axial component, apart from the circumferential component, since the one or more stator conductors **106** are not perpendicular to the magnetic field and/or are not centered relative to the magnetic field. Due to the axial component of force, the shaft **114** connected to the rotor **104** extends **1008** in an axial direction. Further, the shaft **114** rotates due to the circumferential component of the force. In at least one embodiment, the load **112** can be connected to the shaft **114**. In at least some instances, the load is an unbalanced mass that can be connected to the shaft **114**, so that the rotation of the unbalanced mass produces a vibration, and correspondingly produces a vibration relative to any structure to which the motor is attached, like a device. When the power is removed from the electric motor **100**, the axial component of the force dissipates with the dissipation of the current through the one or more stator conductors. The shaft **114** then retracts towards the parked position in the axial direction due to the biasing force of the tension device, which is no longer being opposed by an opposing force having a purposeful axial component.

**FIG. 11** illustrates a device **1102** where various embodiments of the present invention can be applicable. In at least one embodiment, the device **1102** can be a portable electronic device. Examples of the portable electronic device can include, but are not limited to, a laptop, a personal digital assistant (PDA) and a pager. In another embodiment, the device **1102** can be a radio frequency telephone. Examples of the radio frequency telephone can include, but are not limited to, a mobile phone and/or a cellular telephone. The device **1102** includes the electric motor **100**, which includes an input switch **1104** for receiving power from a power supply **1106**. The switch **1104** is coupled to an accelerometer **1108**, which detects the free fall of the device **1102** by measuring acceleration of the device **1102**. Examples of an accelerometer **1108** include, but are not limited to, a piezoelectric accelerometer and an electromechanical accelerometer. In at least some instances a piezoelectric accelerometer can be used to produce a measurable change in a voltage across a dielectric in response to varying amounts of mechanical stress, which can result from the acceleration of an associated mass being acted upon by the force of gravity.

The output of the accelerometer **1108** is coupled to the switch **1104**. When the accelerometer **1108** detects the free fall of the device **1102**, the power supply **1106** is decoupled from the electric motor **100** by the switch **1104**. Upon the removal of power from the motor, the load connected to the electric motor **100** retracts. As a  
5 result, even if the device **1102** is dropped when the motor is active and the shaft is extended (i.e. power is currently being applied), the fall can be detected and power removed, such that the shaft **114** can retract, thereby increasing the chances that the shaft will be saved from getting bent or damaged.

Various embodiments of the present invention, as described above, provide the  
10 following advantages. In at least one embodiment, the method enables the lateral displacement of the shaft within the electric motor, when the motor is not in use or an acceleration of the device is detected, which might occur prior to an impact with a potential to break or deform. Consequently, when the device that includes the electric motor is dropped, the shaft connected to the electric motor will be or can be moved  
15 toward a retracted position, thereby reducing the chances that it might be bent under the impact associated with the weight at the end of the shaft.

While the present invention has been largely described in connection with an unbalanced mass, one ordinarily skilled in the art would appreciate that the present invention can also be used in instances when the motor is being used to rotate a  
20 balanced mass, e.g., a fan, used for cooling purposes, inside a laptop without departing from the teachings of the present invention. In such an instance, the fan can be operated by connecting the fan to an electric motor through a shaft. With similar effect to the unbalanced mass coupled to the motor via a shaft associated with producing a vibrational effect, the shaft associated with the fan and the motor can  
25 similarly be retracted when not in use and/or when the same has been detected as falling, thereby reducing the likelihood that the shaft may be damaged through the result of a jarring impact, and the weight at the end of the shaft.

In the foregoing specification, the invention and its benefits and advantages have been described with reference to specific embodiments. However, one with  
30 ordinary skill in the art would appreciate that various modifications and changes can be made without departing from the scope of the present invention, as set forth in the



claims below. Accordingly, the specification and figures are to be regarded in an illustrative rather than a restrictive sense, and all such modifications are intended to be included within the scope of the present invention. The benefits, advantages, solutions to problems, and any element(s) that may cause any benefit, advantage or  
5 solution to occur or become more pronounced are not to be construed as critical, required or essential features or elements of any or all the claims. The invention is defined solely by the appended claims, including any amendments made during the pendency of this application, and all equivalents of those claims as issued.

## WHAT IS CLAIMED IS:

1. An electric motor used in a device comprising:  
a stator comprising one or more stator conductors for carrying a current when power is applied;
- 5 a rotor comprising one or more permanent magnets for producing a magnetic field, wherein the one or more stator conductors interact with the magnetic field when the power is applied to purposely generate a force having an axial component and a circumferential component; and  
a shaft connected to the rotor wherein the shaft travels along a rotor axis in an  
10 axial direction from a rest position when the power is applied, under an action of the axial component of the force and retracts when the power is removed under an action of a biasing force from a tension device when the axial component of the force is no longer present.
- 15 2. An electric motor of claim 1 wherein the one or more stator conductors are skewed relative to the rotor axis.
3. An electric motor of claim 1 wherein a vector direction of the magnetic field is skewed relative to a radial and an axial direction of the rotor.
- 20 4. An electric motor of claim 1 wherein the one or more stator conductors are skewed relative to the rotor axis and a vector direction of the magnetic field is skewed relative to a radial and an axial direction of the rotor.
- 25 5. An electric motor of claim 1 further comprising an unbalanced mass coupled to the shaft for producing vibration in the device during rotation.
6. An electric motor of claim 1 wherein the tension device is a spring.

7. An electric motor of claim 6 wherein the spring is located co-axial with the shaft between a rotor-body and a motor-housing, further wherein the spring is in a more compressed state when the power is applied, and the spring is in a less compressed state when the power is removed.
- 5
8. An electric motor of claim 6 wherein the spring is located co-axial with the shaft, on exterior and opposite end of the electric motor relative to an unbalanced mass between the end of the shaft and a motor-housing, further wherein the spring is in a more compressed state when the power is applied, and the spring is in a less compressed state when the power is removed.
- 10
9. An electric motor of claim 1 further comprising a bearing arrangement for supporting the sliding of the shaft in the axial direction.
- 15
10. An electric motor in of claim 1 wherein the device is a portable electronic device.
11. An electric motor of claim 1 wherein the device is a radio frequency telephone.
- 20
12. An electric motor of claim 1 further comprising:  
an input switch for providing an input power supply to the electric motor, wherein on detecting a free-fall of the device by an accelerometer coupled to the input switch, the input switch decouples the input power supply from the electric motor.
- 25
13. An electric motor in accordance with claim 1 wherein the electric motor is selected from the group comprising a Permanent Magnet Direct Current (PMDC) motor and a Switched Reluctance Motor (SRM).

14. A vibrator assembly in a device comprising:  
an electric motor comprising:  
a stator comprising one or more stator conductors for carrying a current when power is applied;
- 5 a rotor comprising one or more permanent magnets for producing a magnetic field such that when the power is applied, the one or more stator conductors interact with the magnetic field to purposely generate a force having an axial component and a circumferential component;
- a shaft attached to the rotor, wherein the shaft travels along a rotor axis in an axial direction under an action of the axial component of the force, further wherein  
10 the shaft rotates under the action of the circumferential component of the force when the power is applied, further wherein the shaft retracts under the action of a biasing force from a tension device when the axial component of the force is no longer present when the power is removed; and
- 15 an unbalanced mass coupled to the shaft wherein the unbalanced mass rotates under the action of the circumferential component of the force on the rotor when power is applied.
15. A vibrator assembly of claim 14 wherein the one or more stator conductors are  
20 skewed relative to the rotor axis.
16. A vibrator assembly of claim 14 wherein a vector direction of the magnetic field is skewed relative to a radial and an axial direction of the rotor.
- 25 17. A vibrator assembly of claim 14 wherein the one or more stator conductors are skewed relative to the rotor axis and the vector direction of the magnetic field is skewed relative to a radial and an axial direction of the rotor.

18. A method for controlling lateral positioning of a shaft within an electric motor during operation of the same, the method comprising:

5 biasing a rotor within the electric motor in an axial direction towards a parked position due to a biasing force produced by a tension device where a magnetic field produced by one or more permanent magnets becomes misaligned with one or more stator conductors when power is applied to the electric motor;

10 applying power to the electric motor thereby producing a current in the stator conductors, which interacts with the magnetic field of the one or more permanent magnets to generate a force having an axial component and a circumferential component; and

extending a rotor shaft in an axial direction against the biasing force of the tension device due to the axial component of the purposely generated force.

19. A method of claim 18 further comprising:

15 producing a vibratory force through the rotation of an unbalanced mass attached to the rotor, which rotates, as a result of the circumferential component of the purposely generated force.

20. A method of claim 18 further comprising:

20 removing power from the electric motor, wherein the axial component of the purposely generated force is allowed to dissipate, wherein the biasing force of the tension device causes the rotor to retract in the axial direction towards the parked position.

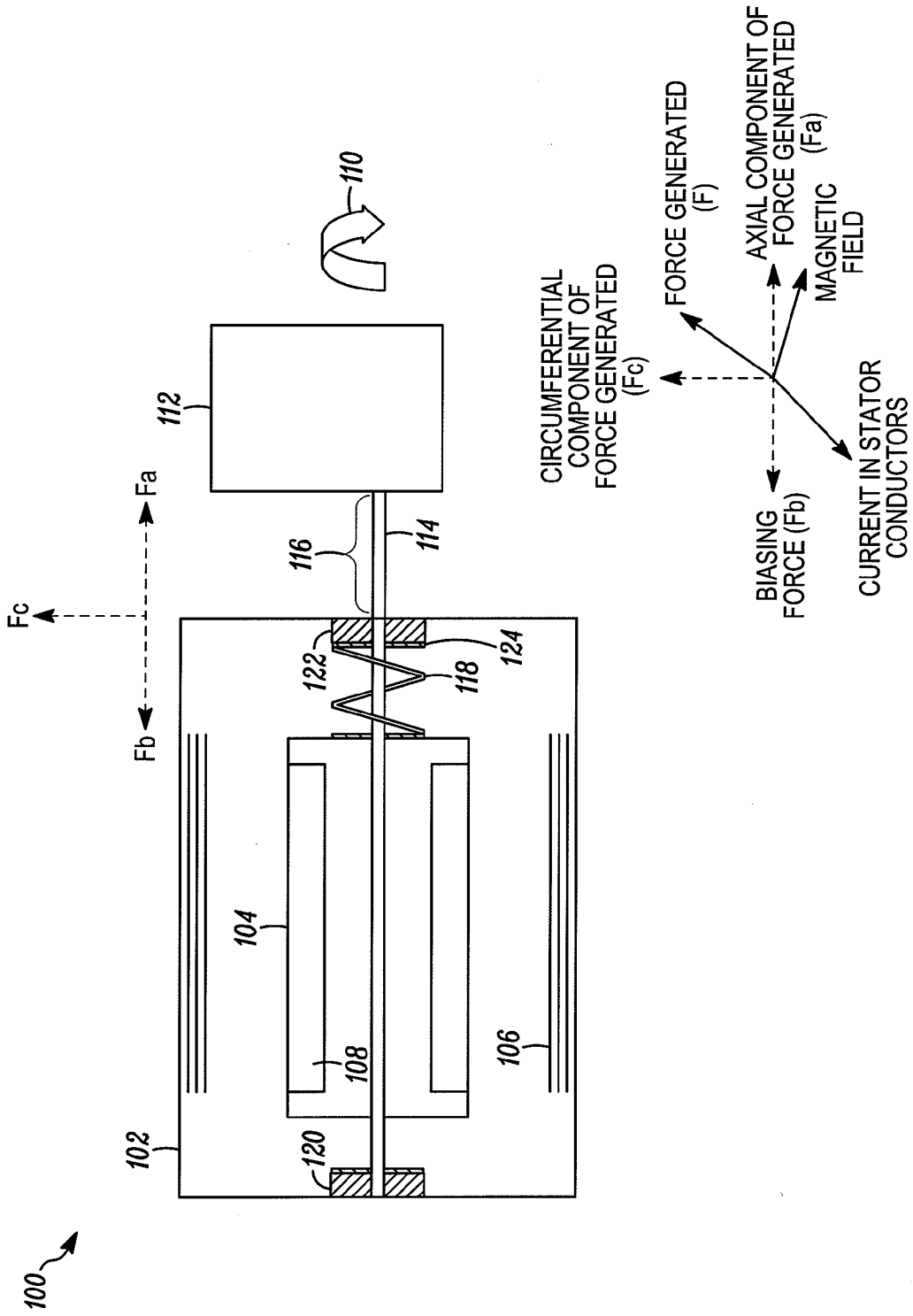

FIG. 1

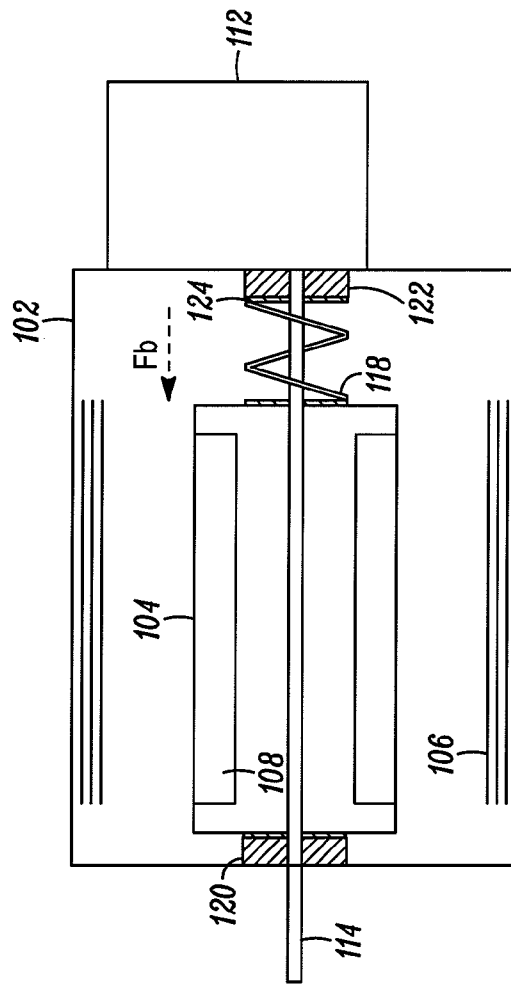

FIG. 2

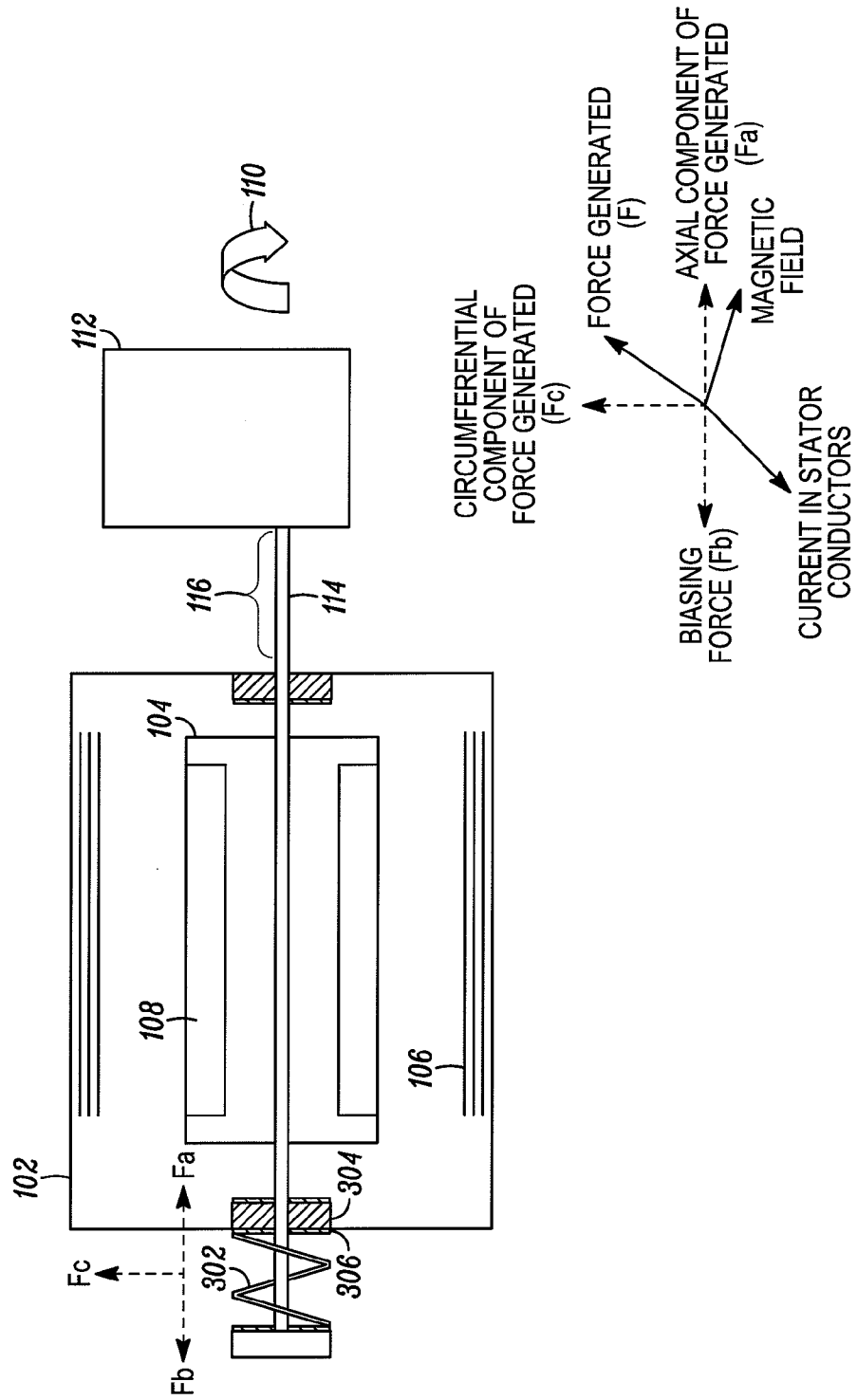

FIG. 3



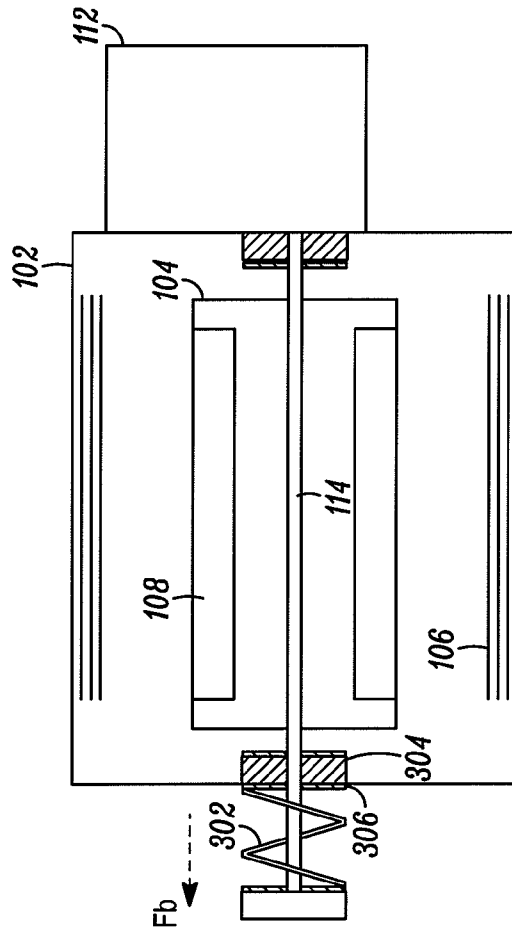

FIG. 4

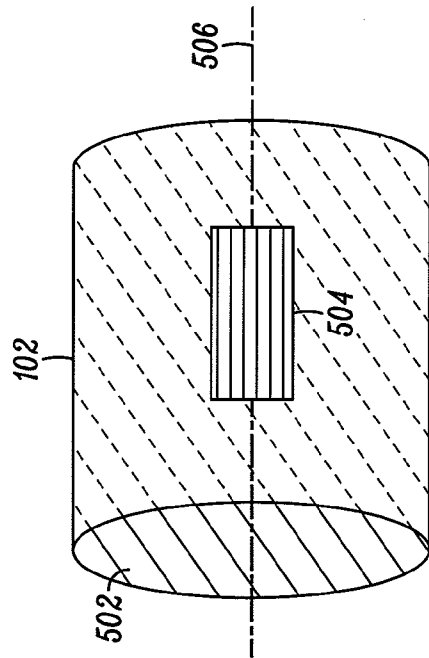

FIG. 5

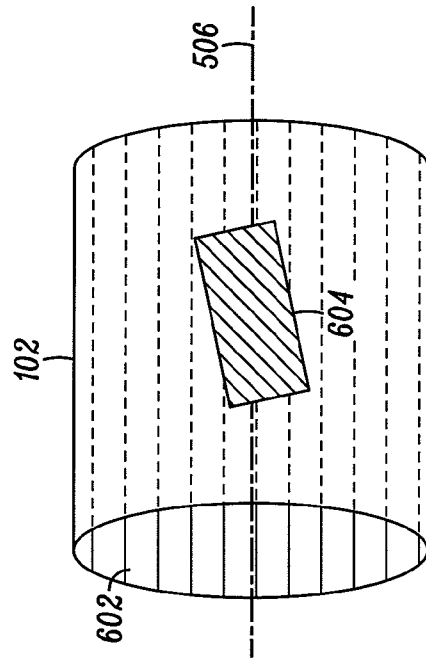

FIG. 6

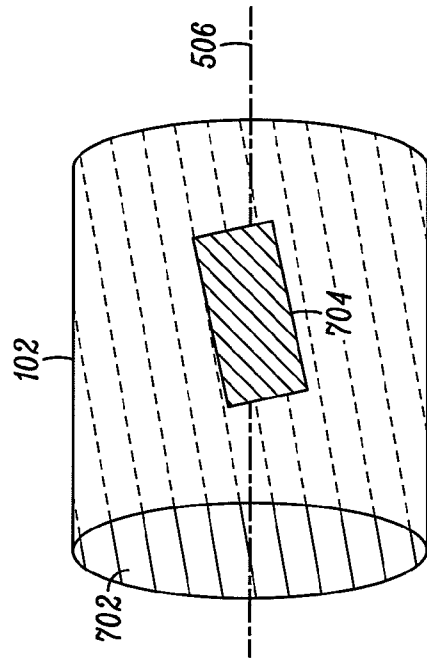

FIG. 7

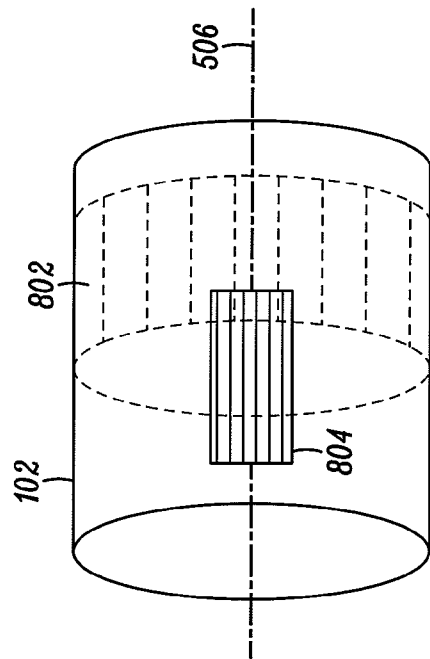

FIG. 8

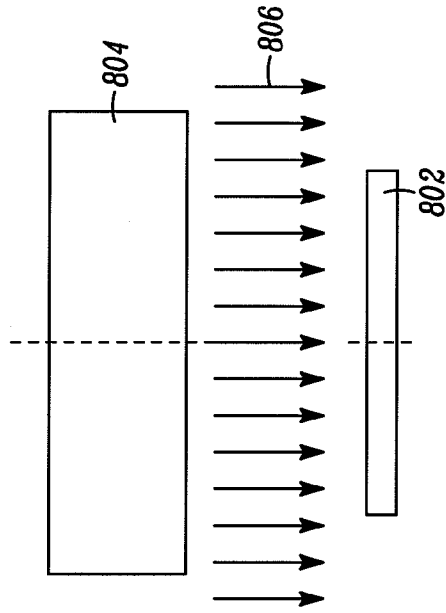

FIG. 9A

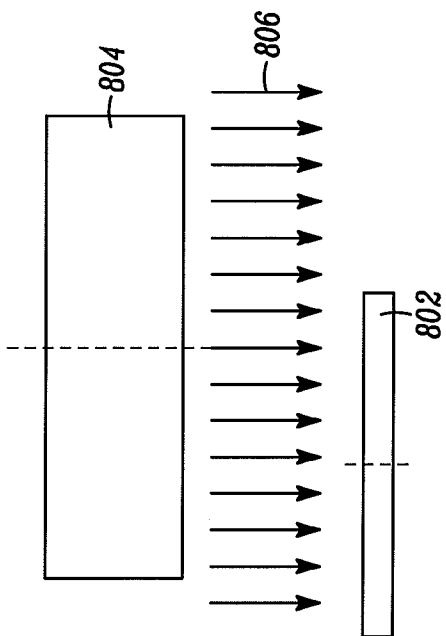
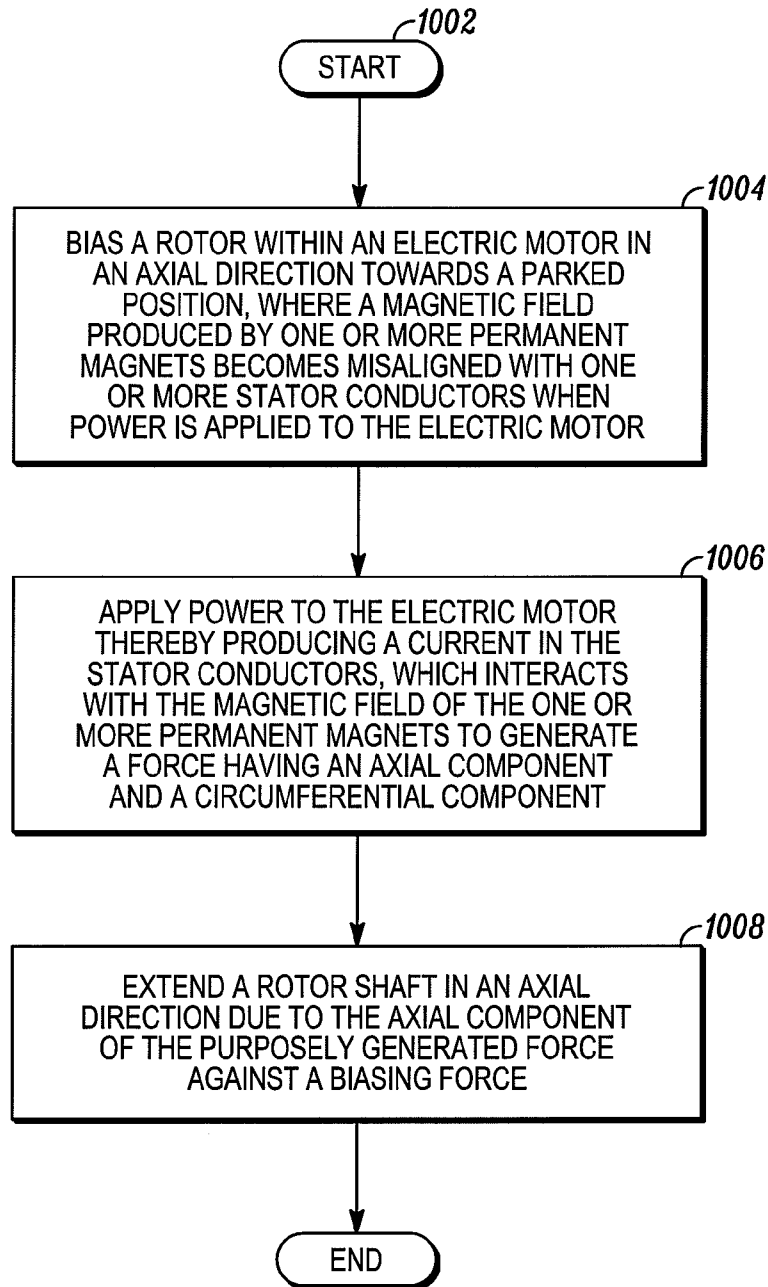

FIG. 9B

*10/11**FIG. 10*

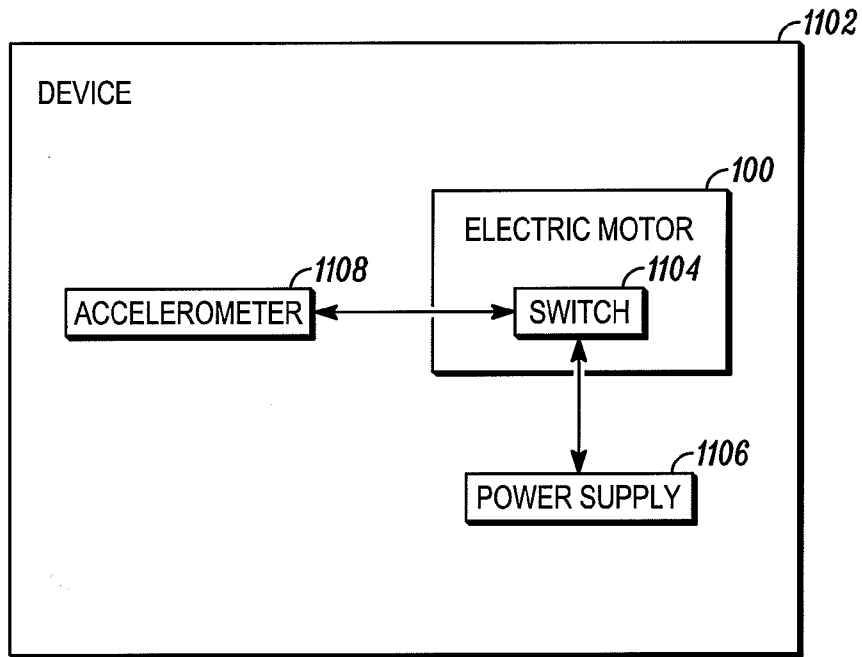

FIG. 11



INTERNATIONAL SEARCH REPORT

International application No.  
PCT/US 07/87728

**A. CLASSIFICATION OF SUBJECT MATTER**  
 IPC(8) - H02K 7/06, 7/10 (2008.04)  
 USPC - 310/80  
 According to International Patent Classification (IPC) or to both national classification and IPC

**B. FIELDS SEARCHED**  
 Minimum documentation searched (classification system followed by classification symbols)  
 IPC(8) - H02K 7/06, 7/10 (2008.04)  
 USPC - 310/80

Documentation searched other than minimum documentation to the extent that such documents are included in the fields searched  
 USPC - 310/79, 80 (text search - see terms below)

Electronic data base consulted during the international search (name of data base and, where practicable, search terms used)  
 PubWEST(PGPB,USPT,USOC,EPAB,JPAB); Google Scholar  
 Search Terms Used: motor, stator, rotor, shaft, retract, magnets, magnetic field, vibration, accelerometer, phone

**C. DOCUMENTS CONSIDERED TO BE RELEVANT**

Category*	Citation of document, with indication, where appropriate, of the relevant passages	Relevant to claim No.
X	US 4,453,515 A (Saji et al.) 12 June 1984 (12.06.1984), entire document, especially FIG. 2 & 6	1-4, 6, 7, 9, 13, 18, 20
Y		5, 8, 10-12, 14-17, 19
Y	US 2003/0228881 A1 (Yamamoto et al.) 11 December 2003 (11.12.2003), para. [0040]-[0041]	5, 8, 10, 11, 14-17, 19
Y	US 2006/0105817 A1 (Naick et al.) 18 May 2006 (18.05.2006), para. [0026], [0028], [0032]	12
A	US 4,381,747 A (Kobayashi et al.) 3 May 1983 (03.05.1983)	1-20

Further documents are listed in the continuation of Box C.

* Special categories of cited documents:	"T" later document published after the international filing date or priority date and not in conflict with the application but cited to understand the principle or theory underlying the invention
"A" document defining the general state of the art which is not considered to be of particular relevance	"X" document of particular relevance; the claimed invention cannot be considered novel or cannot be considered to involve an inventive step when the document is taken alone
"E" earlier application or patent but published on or after the international filing date	"Y" document of particular relevance; the claimed invention cannot be considered to involve an inventive step when the document is combined with one or more other such documents, such combination being obvious to a person skilled in the art
"L" document which may throw doubts on priority claim(s) or which is cited to establish the publication date of another citation or other special reason (as specified)	"&" document member of the same patent family
"O" document referring to an oral disclosure, use, exhibition or other means	
"P" document published prior to the international filing date but later than the priority date claimed	

Date of the actual completion of the international search 5 May 2008 (05.05.2008)	Date of mailing of the international search report <b>22 MAY 2008</b>
--	--

Name and mailing address of the ISA/US Mail Stop PCT, Attn: ISA/US, Commissioner for Patents P.O. Box 1450, Alexandria, Virginia 22313-1450 Facsimile No. 571-273-3201	Authorized officer: Lee W. Young PCT Helpdesk: 571-272-4300 PCT OSP: 571-272-7774
---	--