

Dec. 13, 1932.

M. N. SUCIU

1,891,069

PORTABLE RUBBISH CONSUMER

Filed Feb. 17, 1931

4 Sheets-Sheet 1

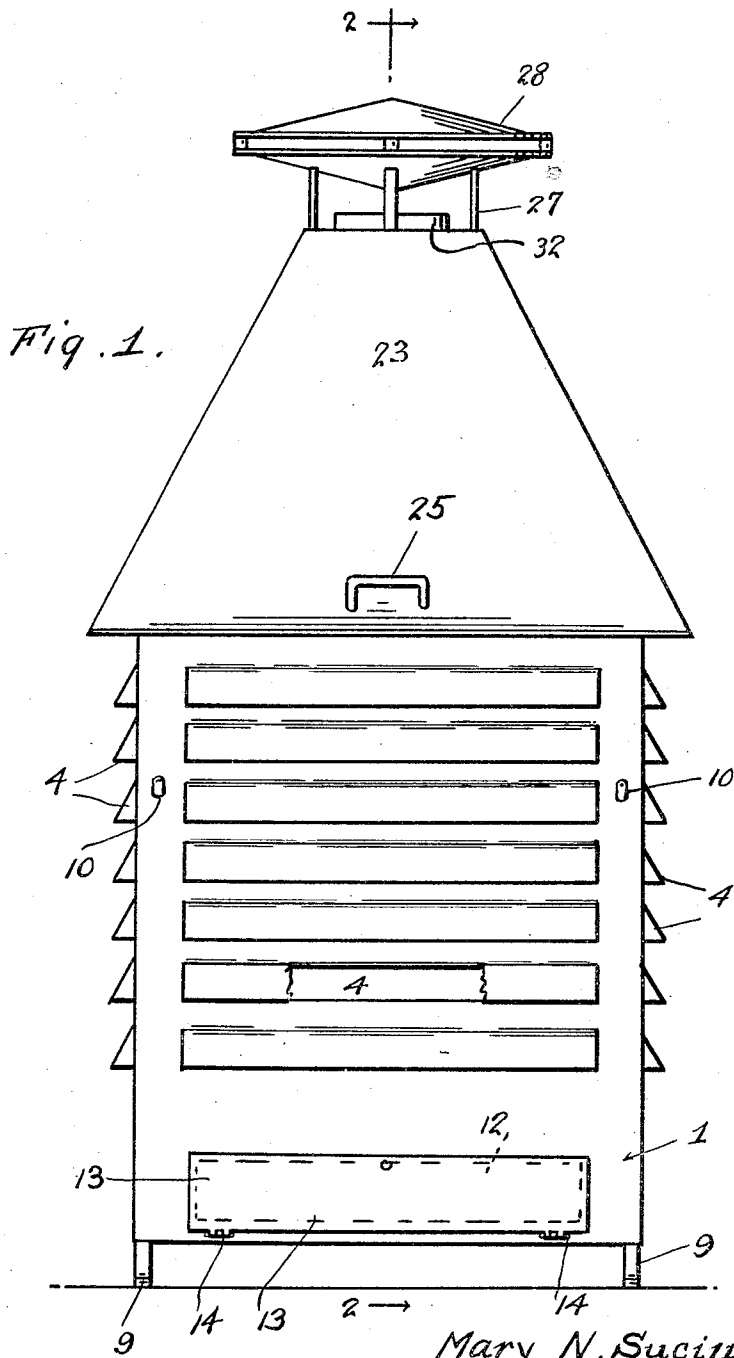

Inventor

Mary N. Suciú

By *Clarence A. O'Brien*
Attorney

Dec. 13, 1932.

M. N. SUCIU

1,891,069

PORTABLE RUBBISH CONSUMER

Filed Feb. 17, 1931

4 Sheets-Sheet 2

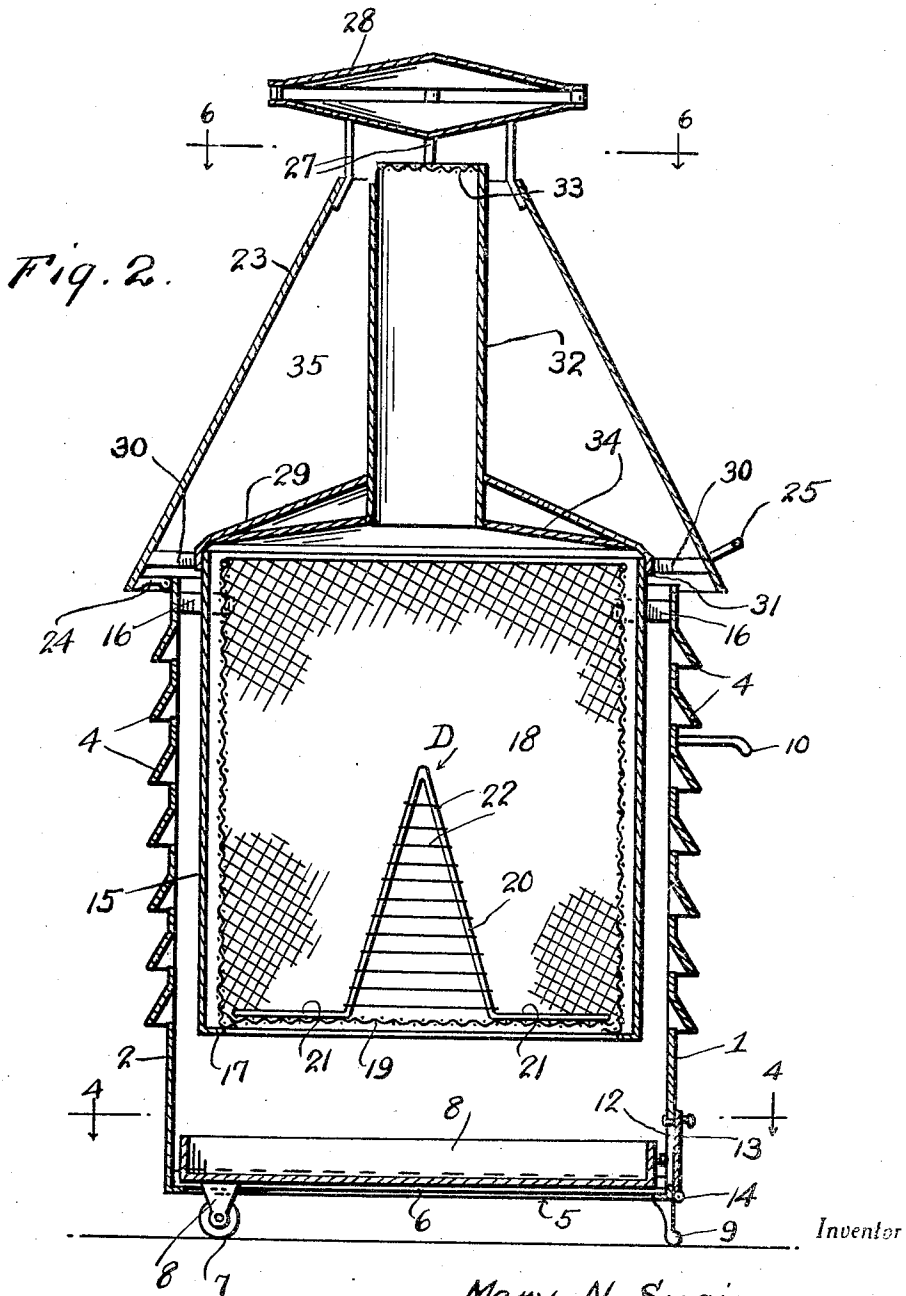

Inventor

Mary N. Suciú

By *Clarence A. O'Brien*
Attorney

Dec. 13, 1932.

M. N. SUCIU

1,891,069

PORTABLE RUBBISH CONSUMER

Filed Feb. 17, 1931

4 Sheets-Sheet 3

Fig. 3.

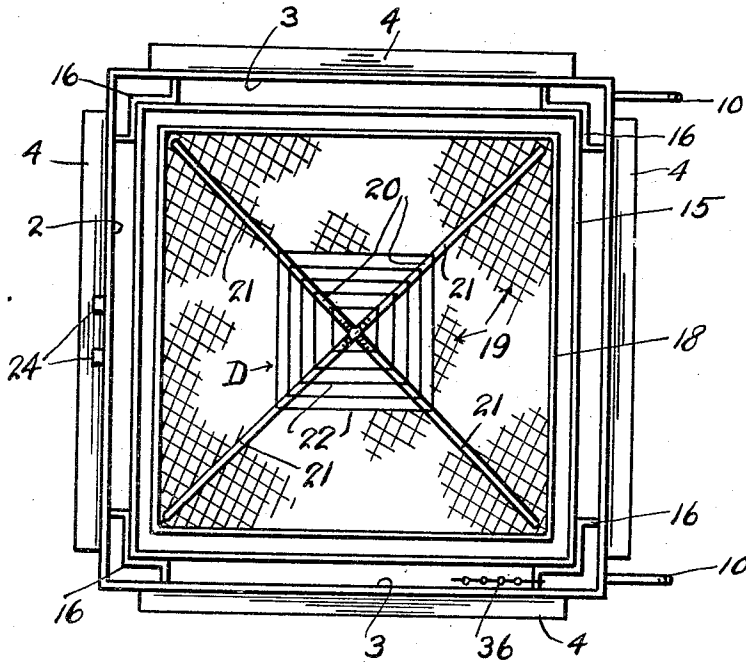
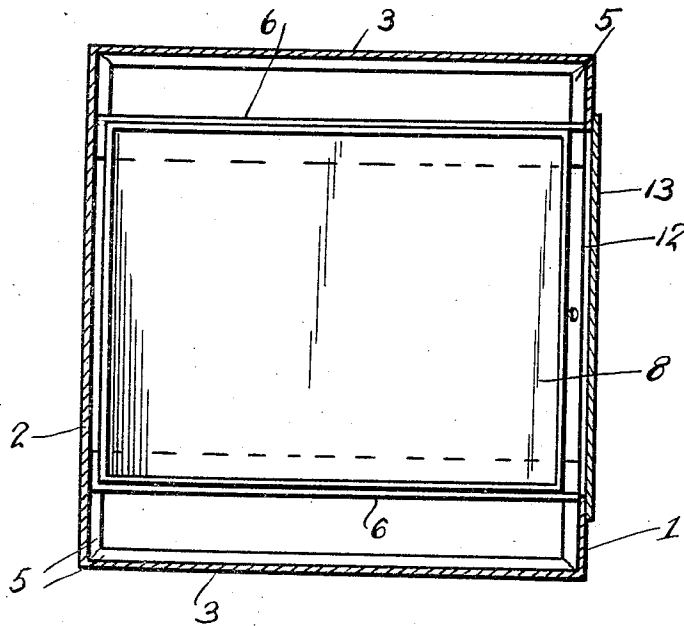

Fig. 4.



Inventor

Mary N. Suciú

By Clarence A. O'Brien
Attorney

Dec. 13, 1932.

M. N. SUCIU

1,891,069

PORTABLE RUBBISH CONSUMER

Filed Feb. 17, 1931

4 Sheets-Sheet 4

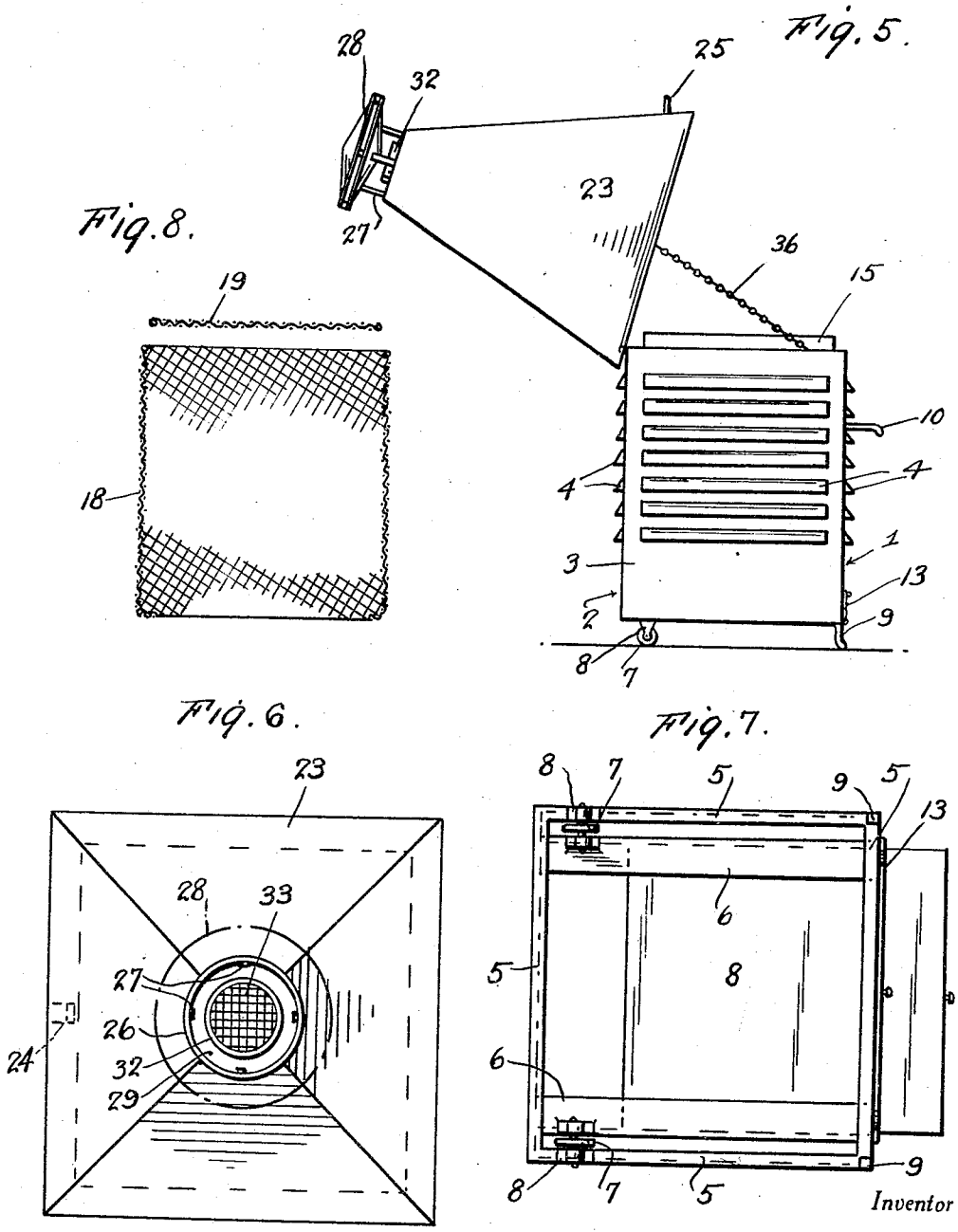

Mary N. Suciú

By Clarence A. O'Brien
Attorney

UNITED STATES PATENT OFFICE

MARY N. SUCIU, OF FLINT, MICHIGAN

PORTABLE RUBBISH CONSUMER

Application filed February 17, 1931. Serial No. 516,429.

This invention relates to certain new and useful improvements in a consumer for rubbish, the primary object of the invention being to provide in a device of this character, a portable casing within which rubbish or the like to be burned, may be arranged, and to otherwise provide a device of this character, which will insure a complete burning of the rubbish placed therein, and which at the same time can be used for the purpose designed, whether placed on a lawn, pavement or other like surface without injury to the surface, will be safe against injury to children, and which will provide for improved sanitation in that, the structure is such as to render possible a complete burning and reduction to ashes of all trash, ordinary wet garbage, without unpleasant and unsanitary odors which generally arise from such refuse, and the rubbish thus being completely reduced to ashes, will be devoid of any substance that would attract vermin.

A still further object of the invention is to provide an improved rubbish consumer including certain new and useful improvements over that type of consumer forming the subject matter of my copending application Serial No. 377,281 filed July 10, 1929.

The above and numerous other objects will become more apparent during a study of the following description, taken in connection with the accompanying drawings, wherein:

Figure 1 is a front elevational view of the consumer,

Figure 2 is a vertical longitudinal sectional view therethrough taken substantially on the line 2—2 of Figure 1 and looking in the direction of the arrows.

Figure 3 is a top plan view of the device with the cover removed.

Figure 4 is a horizontal sectional view taken substantially on the line 4—4 of Figure 2.

Figure 5 is a side elevational view of the device, on a reduced scale, and showing the cover in an opened position.

Figure 6 is a horizontal sectional view taken substantially on the line 6—6 of Figure 2.

Figure 7 is a bottom plan view.

Figure 8 is a detail view of the wire basket forming part of the invention, the bottom of the basket being shown separate therefrom.

With reference more in detail to the drawings, it will be seen that my improved portable rubbish consumer comprises an outer casing which may be formed, and is preferably formed of metal, and is open at the top and bottom thereof. The casing includes a front wall 1, rear wall 2, and side walls 3, each of the walls being provided with suitable ventilating means, the latter being in the nature of a plurality of vertically spaced horizontally disposed louvres 4 as shown.

Each of the walls at the bottom of the casing is provided with an inwardly directed flange 5, and supported between the flanges 5 of the front and rear wall are a pair of ash tray supporting bars or straps 6.

Supporting rollers 7 are journaled between pairs of suitable brackets 8 carried by the straps or bars 6 and the flanges 5 of the side walls 3 adjacent the rear wall 2 of the casing. The casing at the front thereof adjacent the corners of the casing is provided with relatively fixed supporting legs 9. Hand grips or handles 10 project forwardly of the casing, and it will be evident that one gripping the handles 10, and suitably tilting the casing as to raise the legs 9 out of engagement with the ground, may readily move the casing over the ground from one place to another.

The bars 6 slidably support thereon an ash receiving tray or receptacle 11 slidable through a suitable opening 12 provided therefor in the lower portion of the front wall 1. The opening 12 is normally closed by an ash door 13 hinged at its lower edge as at 14. The bars or straps 6 are in the nature of angle irons and provide a suitable guide for the ash tray 11 during sliding movement of the same.

Arranged within the casing, is a flame shield 15 that is preferably formed of metal, open at its top and bottom, the shield being preferably of a shape in cross section corresponding to the cross sectional shape of the casing. The walls of the shield 15 are ar-

ranged in spaced relation to the corresponding walls of the casing, and said shield is suspended from the walls of the casing in spaced relation to said walls through the medium of
 5 combined spacing and suspension brackets 16 arranged one at each corner of the casing, and of suitable construction to engage the walls of the flame shield 15 at the corners of the flame shield. It will be noted that at
 10 its upper end the flame shield 15 projects slightly upwardly beyond the corresponding end of the casing, and the lower end of the flame shield terminates above the ash tray 8.

15 The walls of the flame shield 15 at the bottom of the flame shield are provided with inwardly directed flanges 17 upon which rests the lower end of a rubbish container designated generally by the reference character 18.
 20 The rubbish container 18 is preferably in the nature of a wire mesh basket of suitable depth, and preferably of a shape in cross section corresponding to the cross sectional shape of the flame shield 15. When arranged
 25 within the flame shield 15, the walls of the basket are preferably arranged in slight spaced relation to the corresponding walls of the flame shield, as to insure proper circulation of air through the basket.

30 As suggested in Figure 8, the basket is opened at its top and bottom, and the walls of the basket at the bottom thereof turned inwardly to provide a ledge for accommodating a removable wire mesh bottom 19.

35 In actual practice, it has been found that when material or rubbish of a character that is not highly inflammable, is placed within the basket, and during burning of the rubbish, such material has a tendency to "ball up" or cake in the center, and to overcome this
 40 fault, there is provided, what may be termed, for the sake of convenience, a "spreader or distributor", the same comprising a substantially pyramidal wire frame structure designated generally by the reference character
 45 D and which may be formed either integrally with the bottom of the basket or separate and independently therefrom as is apparent.

50 For the sake of example I have shown a distributor D formed independently of the bottom of the basket, and including a plurality of rods 20 converging toward one another at their upper ends and suitably welded or otherwise secured together at the apex of
 55 the pyramid. At the base of the pyramid, the rods 20 are spaced outwardly or laterally as at 21 to provide a support for the pyramid for retaining the same in proper position within the bottom of the basket. Forming
 60 the body of the pyramid, are a plurality of vertically spaced rectangular frames 22 connecting the rods 20, and increasing in size from the apex to the base of the pyramidal distributor. A substantially frusto-pyramidal cover or lid 23 is provided for the casing
 65

and at its lower edge is hinged as at 24 to the upper edge of the rear wall 2 of the casing. The cover 23 at the front thereof is provided with a suitable handle 25 to facilitate raising and lowering of the cover to open
 70 and closed position.

Supported by brackets 27 rising from the upper end of the lid 23 is a suitable spark arrester 28. Arranged within the lid or cover
 75 23 is a frusto-conical flame shield 29 that is supported within the lid, and spaced from the walls of the lid through the medium of suitable supporting and spacing brackets 30. At its lower edge, the flame shield 29 is provided with a flange 31 that telescopically engages the upper edge of the flame shield 15. Thus the flame shield 29 provides as it were
 80 a cover for the flame shield 15.

The flame shield 29 has extending through the apex thereof, the lower end of a smoke
 85 stack 32 that extends upwardly through the lid 23. In the upper end of the smoke stack 32 is arranged a wire mesh spark arresting disk 33.

Integral with the lower end of the smoke
 90 stack 32 is a baffle plate 34 arranged within the confines of the flame shield 29 and the baffle plate 34 at its peripheral edge is suitably welded or otherwise secured to the flame shield 29.
 95

The baffle plate 34 will be especially useful when the consumer is relatively large in size and the heat from the burning rubbish is very intense. The baffle plate serves the purpose of meeting the most direct and severe attack
 100 of the flame while the flame shield 29 in turn will further reduce the intensity of the heat to such a degree that it is successfully dealt with by means of the ventilated casing. In this connection, it may be also noted, that the
 105 relative position of the lid or cover 23, and flame shield 29, is such as to provide therebetween a ventilating or air space 35 that opens not only into the space between the walls of the flame shield 15 and the walls of
 110 the outer casing, but also opens to the atmosphere at the upper end of the casing as is apparent from a study of Figure 2.

From the foregoing, it will be apparent that in providing a rubbish consumer of this character proper and sufficient ventilation is provided, which not only insures a complete combustion of the rubbish, resulting in a complete reduction of the rubbish to ashes, but also will permit of the outer casing as
 120 well as the lid or cover 23 therefor to remain at all times cool, so that children or others coming into contact with the casing may do so without risking injury from burns.

Further, the casing as well as the lid therefor is painted, thus enhancing the attractiveness of the device and insures protection from the elements thus preventing rust and consequent early deterioration.
 125

From the foregoing then it will be seen 130

that I have devised a rubbish consumer, that is portable, can be readily transported from place to place, can be used with reasonable safety wherever desired, may be attractive and pleasing in appearance, without sacrificing its effectiveness for the purpose for which it was designed, insures a complete combustion of rubbish, provides for a sanitary disposal of rubbish, and which may be manufactured at a nominal cost.

As shown, and if desired, the swinging of the cover or lid 23 to an open position may be limited through the medium of a flexible element or chain 36 connected at one end with the closure or lid, and at its opposite end to any fixed part of the device, preferably one of the flame shield supporting brackets 16.

Even though I have herein shown and described the preferred embodiment of the invention, it is to be understood that the same is susceptible of changes, variations, modifications and improvements coming within the scope of the appended claims.

Having thus described my invention, what I claim as new is:

1. A rubbish consumer comprising in combination a casing, the walls of which are provided with louvres, a flame shield arranged within said casing and spaced relative to the walls of said casing, said casing being open at its top and bottom, said flame shield being open at its top and bottom, and the walls of said flame shield at the bottom thereof directed inwardly to provide a supporting flange extending along all sides of the flame shield, a wire mesh rubbish receptacle arranged in said flame shield for rest on said flange, and a distributor arranged within said wire mesh receptacle, said distributor comprising a pyramidal body portion extending axially of said wire mesh receptacle, a hinged closure for the upper end of said casing adapted to be opened for insertion of rubbish, a second flame shield arranged in said closure in spaced relation to the walls of said closure, and adapted to close the first mentioned flame shield when said closure is in a closed position.

2. A rubbish consumer comprising a casing, wheels supporting said casing adjacent the rear thereof, supporting legs for the casing adjacent the front thereof, handle members extending laterally from the casing at the front thereof, a flame shield having an inwardly extending flange on the lower portion thereof arranged in said casing in spaced relation to the walls of said casing a wire mesh rubbish receptacle arranged in said flame shield for rest on said flange, said flame shield being open at its top and bottom, a hinged closure for the open top of said casing adapted to be opened for insertion of rubbish, a second flame shield arranged in said closure in spaced relation to the walls of said closure and adapted to engage the upper

edge of said first mentioned flame shield for closing the latter, a smoke stack extending through the closure, and through the flame shield arranged in said closure, and a baffle plate integral with the lower end of the smoke stack, and arranged within the confines of the flame shield arranged in said closure.

3. A rubbish consumer comprising a casing, wheels supporting said casing adjacent the rear thereof, supporting legs for the casing adjacent the front thereof, handle members extending laterally from the casing at the front thereof, a flame shield having an inwardly extending flange on the lower portion thereof arranged in said casing in spaced relation to the walls of said casing, a wire mesh rubbish receptacle arranged in said flame shield for rest on said flange, said flame shield being open at its top and bottom, a hinged closure for the open top of said casing, adapted to be opened for insertion of rubbish, a second flame shield arranged in said closure in spaced relation to the walls of said closure and adapted to engage the upper edge of said first mentioned flame shield for closing the latter, a smoke stack extending through the flame shield arranged in said closure, a baffle plate integral with the lower end of the smoke stack, and arranged within the confines of the flame shield arranged in said closure, a spark arrester on the upper end of said closure and a screen disk arranged in the upper end of the smoke stack.

4. A rubbish consumer comprising a casing, wheels supporting said casing adjacent the rear thereof, supporting legs for the casing adjacent the front thereof, handle members extending laterally from the casing at the front thereof, a flame shield arranged in said casing, a closure for the open top of said casing adapted to be opened for insertion of rubbish, a second flame shield arranged in said closure and adapted to engage the upper edge of said first mentioned flame shield for closing the latter, a smoke stack through the flame shield arranged in said closure, and a baffle plate integral with the lower end of the said mentioned smoke stack, and arranged within the confines of the flame shield arranged in said closure, a tray arranged in the bottom of said casing for receiving ash, said casing having one wall thereof provided with an opening for accommodating the tray, a hinged door normally closing said opening, a perforate receptacle arranged within the confines of the first mentioned flame shield, and a distributor arranged within the receptacle.

In testimony whereof I affix my signature.
MARY N. SUCIU.