

H. T. LEE.

Improvement in Packing for Steam and Water Joints.

No. 128,737.

Patented July 9, 1872.

Fig. 1.

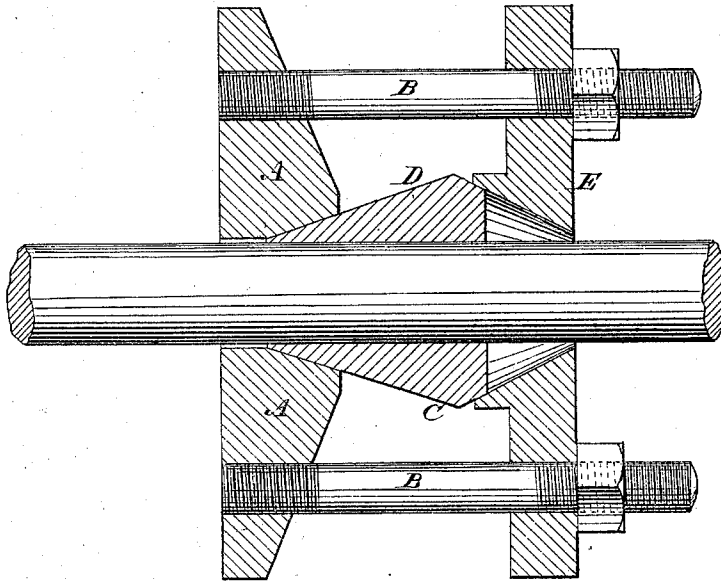

Fig. 3.

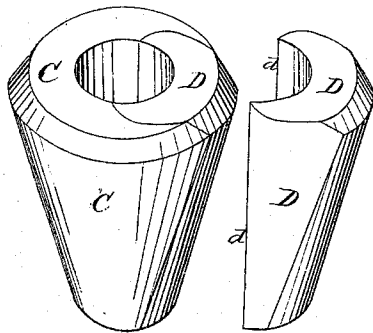

Fig. 2.

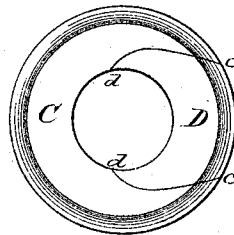
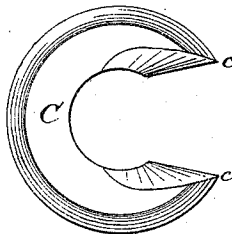

Fig. 4.



Witnesses:

S. J. Norris.
R. Greenway

Inventor:

Harvey T. Lee, by.
Dw. Beards & Co.
attys.

UNITED STATES PATENT OFFICE.

HARVEY THOMAS LEE, OF CHICAGO, ILLINOIS.

IMPROVEMENT IN PACKINGS FOR STEAM AND WATER JOINTS.

Specification forming part of Letters Patent No. 128,737, dated July 9, 1872.

To all whom it may concern:

Be it known that I, HARVEY T. LEE, of Chicago, in the county of Cook and State of Illinois, have invented a new and Improved Packing for Steam and Water Joints; and I do hereby declare that the following is a full and exact description of the same, reference being had to the accompanying drawing and to the letters of reference marked thereon.

This invention has for its object the production of an improved packing for the joint between a moving piston and stationary head; and consists mainly in the peculiar construction of the cylinder-head, and the combination with it of a packing-ring and follower, by means of which the stuffing-box ordinarily used is dispensed with, as will be fully described hereinafter.

In the drawing, Figure 1 represents a sectional elevation of the piston cylinder-head, packing-ring, and follower with its securing-bolts; and Figs. 2, 3, and 4 represent various views of the packing-ring.

To enable others skilled in the art to make and use my invention, I will now proceed to describe fully its construction and manner of operation.

A represents the cylinder-head, which may be constructed in any proper manner, but is specially provided with a centrally-located conical opening, as shown. To it are attached the bolts B B at any proper points and in any suitable manner. The packing-ring consists of two or more parts, C and D, constructed as represented in Figs. 2, 3, and 4, which parts when united form the frustum of a cone, which has a longitudinal central opening through it from end to end of equal diameter throughout. The edge of its larger end, also, is inwardly inclined, as clearly shown in Fig. 1. The part D is so formed that its inner vertical edges *d d* are made thin, and so, also, are the outer vertical edges *c c* of the part C, by means of which construction they are adapted to adjust themselves readily under pressure to the parts

against which they bear. F represents the gland or follower, which is provided with a centrally-located conical opening, as shown, and with side holes for the reception of the ends of the bolts B B. When all the parts are in position they appear in section, as represented in Fig. 1. The piston-rod is inserted in the proper opening in the cylinder-head, and the packing-ring C D is placed about it with its small end resting in the conical recess formed between the inclined opening of the cylinder-head and the piston. The follower F is also placed in position with its inclined surface bearing upon the inclined edge of the larger end of the packing-ring, in which position it is secured by means of the bolts B B and suitable nuts. The inclines of the packing-ring correspond, of course, with the inclines of the cylinder-head and follower with which they are in contact.

From the foregoing description it will be readily understood that the packing-ring as it wears away may be forced further into the conical opening of the cylinder-head to compensate for the wear by advancing the follower by means of the bolt and nuts.

By means of the described construction a perfectly tight joint is formed and the stuffing-box ordinarily employed is dispensed with. The packing-ring may be made of any suitable composition which will enable it to be properly compressed, as may be necessary.

Having thus fully described my invention, what I claim as new, and desire to secure by Letters Patent, is—

The cylinder-head A, packing-ring C D, and follower E, combined, substantially as described, for the purpose set forth.

In witness that the above invention is claimed by me I have hereunto set my hand and seal.

HARVEY T. LEE. [L. S.]

Witnesses:

CYRUS J. CORSE,
PLEASANT AMICK.