

(No Model.)

T. KITSON.
BLOWER.

No. 526,236.

Patented Sept. 18, 1894.

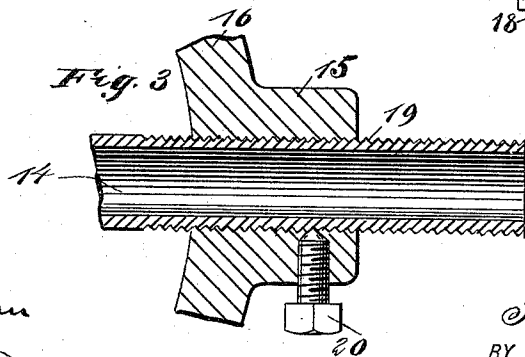
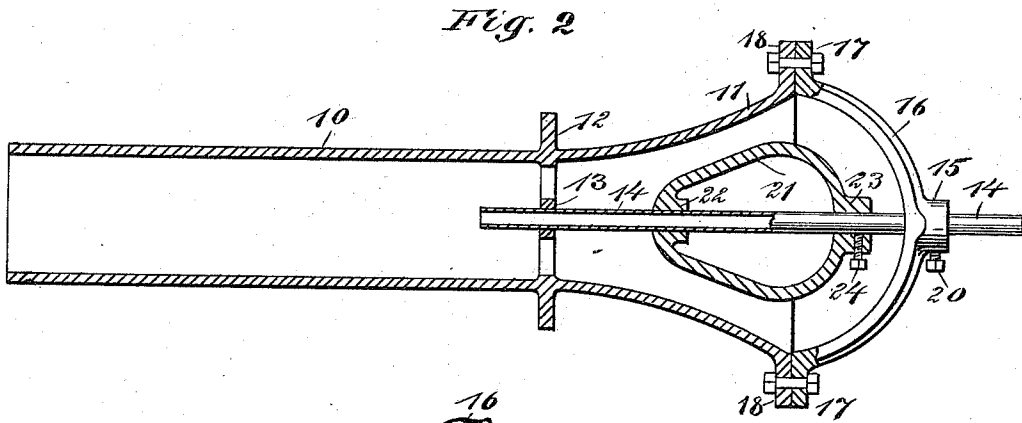
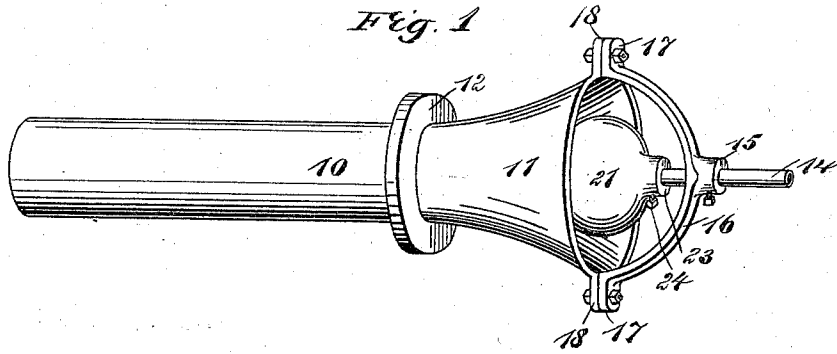

WITNESSES:
J. A. Bergstrom
C. Sedgwick

INVENTOR
T. Kitson
BY *Munn & Co.*
ATTORNEYS.

UNITED STATES PATENT OFFICE.

THOMAS KITSON, OF STROUDSBURG, PENNSYLVANIA.

BLOWER.

SPECIFICATION forming part of Letters Patent No. 526,236, dated September 18, 1894.

Application filed September 3, 1892. Serial No. 444,972. (No model.)

To all whom it may concern:

Be it known that I, THOMAS KITSON, of Stroudsburg, in the county of Monroe and State of Pennsylvania, have invented a new and Improved Blower, of which the following is a full, clear, and exact description.

My invention relates to improvements in steam blowers such as are used for creating a forced draft in boiler and other furnaces; and the object of my invention is to produce an extremely simple and durable blower which is adapted to create a very strong draft, which may be applied to any ordinary furnace without changing or renewing the grates, and the use of which will enable a high and even steam pressure to be kept up and cheap fuel to be used.

To these ends my invention consists in a blower, the construction of which will be hereinafter described and claimed.

Reference is to be had to the accompanying drawings, forming a part of this specification, in which similar figures of reference indicate corresponding parts in all the views.

Figure 1 is a perspective view of the blower embodying my invention. Fig. 2 is a central longitudinal section of the same; and Fig. 3 is an enlarged detail sectional view showing the means of adjusting the steam nozzle.

The body of the blower consists of a pipe 10, which has a bell-shaped end 11, and near the junction of the bell-shaped portion with the body is a flange 12, which strengthens the blower and facilitates its adjustment in a support; and on the inside of the blower, opposite the flange, is a transverse support 13, having passages for the air through it, this support being for the purpose of securing the inner end of the steam nozzle 14, which nozzle extends centrally and longitudinally into the pipe or body 10, the outer end portion of the nozzle being held in a central boss 15, on the yoke 16, the latter being made to span centrally the mouth of the bell-shaped portion 11 and having at its ends lugs 17, which are bolted to similar lugs 18, on the bell-shaped portion 11.

The nozzle 14 is screw threaded on the part adjacent to the boss 15, as shown at 19 in Fig. 3, and this threaded portion fits a correspondingly threaded portion of the boss, as shown clearly in Fig. 3, and by this construction,

the nozzle may be adjusted in or out so as to bring it into the most efficient position. The nozzle is also held in place by a set screw 20, which projects through the boss 15 and impinges on the nozzle.

On the nozzle 14 and inside of the yoke 16 is a hollow conical valve 21, which is held to slide on the nozzle, and the smaller end of which is placed inward. This valve may be of any desired shape, but to give it the greatest efficiency its sides should approximate to the shape of the bell-shaped portion 11 of the body 10.

The smaller end of the valve is thickened, as shown at 22, where it slides on the nozzle, and the larger end of the valve terminates in a hub 23, which fits the nozzle and which is provided with a set screw 24, adapted to impinge upon the nozzle, and by this means the valve may be held in the desired position.

The operation of the blower is as follows:—The body portion 10 is secured in some suitable support so as to point and deliver into the desired locality, and a steam pipe is coupled to the outer end of the nozzle 14. The steam rushes inward through the nozzle and into the body 10, and the volume of steam creates a great suction which draws in the air around the valve 21 and the air and steam are delivered into or beneath the furnace.

It will be seen that the valve 21 may be adjusted in and out so that the requisite quantity of air will pass through the bell-shaped portion 11 and into the body 10.

Having thus described my invention, I claim as new and desire to secure by Letters Patent—

1. A steam blower, comprising a pipe having a bell shaped mouth, a nozzle extending through the mouth and held to deliver into the pipe, and a valve approximately conical in shape secured to the nozzle and held within the mouth, the smaller end of the valve being placed inward, and the said valve being adjustable in and out upon the nozzle, substantially as described.

2. A steam blower, comprising a pipe having a bell shaped mouth, and a straight body portion, a yoke extending across the mouth, a transverse support located within the pipe at or near the junction of the mouth with the body portion, a steam nozzle extending into

the pipe and having its inner end secured to the transverse support and its outer end to the yoke, a conical valve held within the mouth and adjustable longitudinally on the nozzle, and means for holding the said valve in position, substantially as described.

3. A blower, comprising a pipe having a flaring mouth, a yoke extending across the mouth, a fixed support held within the pipe, a nozzle held in said yoke and fixed support, and adjustable in and out in the pipe, and a conical valve secured to the nozzle and held within the said mouth and adjustable longitudinally on the nozzle, substantially as described.

4. A blower, comprising a pipe having a bell shaped mouth and a straight body portion, a yoke extending across the mouth and provided with a central boss having a screw threaded opening, a transverse support within

the pipe, a nozzle arranged centrally in the pipe, and having its inner end held in the transverse support and having its outer end screw threaded to fit the threaded portion of the boss, whereby the said nozzle may be adjusted in or out, a set screw projecting through the boss and adapted to impinge on the nozzle, and a conical valve held to slide longitudinally on the nozzle within the said mouth, the said valve having its sides shaped to approximately correspond to the wall of the mouth and having a hub at its outer or larger end provided with a set screw adapted to impinge upon the nozzle, substantially as described.

THOMAS KITSON.

Witnesses:

C. D. BRODHEAD,
CHAS. BELL.