





PT, RO, SE, SI, SK, TR), OAPI (BF, BJ, CF, CG, CI, CM, GA, GN, GQ, GW, ML, MR, NE, SN, TD, TG).

**Published:**

— *without international search report and to be republished upon receipt of that report*

**Declaration under Rule 4.17:**

— *as to applicant's entitlement to apply for and be granted a patent (Rule 4.17(ii))*

## A UNIT LIFTER ASSEMBLY

### FIELD OF THE INVENTION

5

The present invention relates to a unit lifter assembly for a sawing and sorting system. The assembly interacts with, or includes, a dicing machine which saws ("dices") a substrate with many integrated circuits formed onto it to singulated individual integrated circuits. The invention in particular relates to a unit lifter assembly of the lifter assembly.

10

### BACKGROUND OF THE INVENTION

Conventionally, a plurality of integrated circuits are formed simultaneously on a semiconductor substrate, and the substrate is then diced to form singulated integrated circuits. The singulated integrated circuits are then picked up after the dicing to be inspected, tested and / or sorted.

Figure 1 shows the lifter assembly 11A of the conventional sawing and sorting systems, which includes a number of individual unit lifter assemblies 11a. Each unit lifter assembly 11a includes a number of individual unit lifters 11b for lifting the singulated integrated circuits after dicing is performed. Figure 2a shows a side view of a unit lifter assembly 11a and Figure 2b shows the cross-sectional view along the line A-A. Each unit lifter 11b lifts a respective singulated integrated circuit 7a for inspecting, testing and / or sorting. Each individual unit lifter 11b is actuated by a respective individual miniature servo motor 11d, which moves the unit lifter down towards the substrate to engage a singulated integrated circuit, and then up to move the engaged integrated circuit to a second location.

30 In the conventional unit lifter assembly, the number of unit lifters which can be positioned onto the unit lifter assembly is limited by the number of servo motors 11d, which can be physically installed onto the assembly while still maintaining or minimising the operating

stroke of the linear motor which the unit lifter assembly is mounted on. This will also minimise the footprint of the machine. The minimum pitch required between the motors provides a limitation to the actual number of unit lifters on each assembly. Typically, four unit lifters are installed in each unit lifter assembly.

5

## SUMMARY

The invention provides a unit lifter assembly for lifting singulated integrated circuits singulated from a semiconductor substrate including a plurality of rows and columns of unit lifters and a plurality of actuating means, each operatively engaged to at least one unit lifter, wherein each actuating means is arranged staggered one after another so that a pitch from one actuating means to another is minimised.

10 In the embodiment, the actuating means is configured so that adjacent actuating means are not along a same arbitrary horizontal axis in a manner so that it is staggered.

Preferably, each actuating means is operatively engaged to each unit lifter so that each unit lifter is powered individually.

20

Still preferably, each actuating means is operatively engaged to a plurality of unit lifters so that the unit lifters are powered plurally.

Still preferably, the actuating means is a miniature motor and a rack and pinion assembly.

25

In a preferred embodiment, the unit lifter has an engagement means at one end to engage a singulated integrated circuit.

30 Preferably, in this embodiment, the engagement means is a conduit having an aperture at one end, the conduit being provided with vacuum so that when in use, a singulated integrated circuit is lifted via the vacuum force through the aperture.

In another embodiment, the engagement means further includes a pad to provide a wider area of vacuum force to a singulated integrated circuit so as to prevent damage to the engaged integrated circuit- and to create better vacuum sealing.

5

Preferably, the engagement means is a needle of a syringe.

In another embodiment of the present invention, the assembly further includes a housing wherein the plurality of unit lifters are congregated.

10

Preferably, a guiding means is included in the housing for each unit lifter.

Preferably, the actuating means are set on the external of the housing.

15

#### **BRIEF DESCRIPTION OF THE FIGURES**

It will be convenient to further describe the present invention with respect to the accompanying drawings which illustrate possible arrangements of the invention. Other arrangements of the invention are possible, and consequently the particularity of the accompanying drawings is not to be understood as superseding the generality of the preceding description of the invention.

20

Fig. 1 is a unit lifter assembly in the prior art;

25

Fig. 2a is a side view of a unit lifter assembly in the prior art;

Fig. 2b is a cross-sectional view of the unit lifter assembly in along A-A of Fig. 2a;

30 Fig. 3a is a preferred embodiment of the invention;

Fig. 3b is another preferred embodiment of the invention;

Figure 3c is a preferred embodiment of a unit lifter assembly in a housing;

Fig. 4 shows the engagement of the gears in a rack and pinion;

5

Fig. 5a is a perspective view of a preferred embodiment of the invention;

Fig. 5b is a top view of Fig. 5a;

10 

Fig. 5c is a side view of Fig. 5a;

Fig. 5d is a cross-sectional view along A-A of Fig. 5c.

15 

Fig. 6a is a perspective view of another example of the preferred embodiment of the invention;

Fig. 6b is a top view of the Fig 6a;

Fig. 6c is a side view of the Fig 6a;

20

Fig. 6d is a cross-sectional view along A-A of Fig. 6b.

Fig. 7a shows a fourth embodiment of the unit lifter;

25 

Fig. 7b shows a fifth embodiment of the unit lifter; and

Fig. 8 is a perspective view of a unit lifter.

30 

**DETAILED DESCRIPTION OF THE EMBODIMENTS**

Reference will now be made in detail to the preferred embodiments of the invention, examples of which are illustrated in the accompanying drawings. While the invention will be described in conjunction with the preferred embodiments, it will be understood that they are not intended to limit the invention to these embodiments. On the contrary, the invention is intended to cover alternatives, modifications and equivalents, which may be included within the spirit and scope of the invention as defined by the appended claims. Furthermore, in the following detailed description of the present invention, numerous specific details are set forth in order to provide a thorough understanding of the present invention. However, it will be obvious to one of ordinary skill of the art that the present invention may be practiced without these specific details. In other instances, well known methods, procedures, components, and features have not been described in detail as not to unnecessarily obscure aspects of the present invention.

In the preferred embodiment as shown in Figure 3,3a, the invention provides an apparatus for lifting singulated integrated circuits singulated from a semiconductor substrate including a plurality of rows and columns of unit lifters 12, and a plurality of actuating means 14, each actuating means 14 is operatively engaged to each unit lifter 12 so that each unit lifter is powered individually. In this preferred embodiment, each actuating means 14 is arranged staggered one after another so that a pitch from one actuating means 14 to another is minimised so that a density of unit lifters per assembly is maximised. In an alternative, the actuating means power more than one unit lifter at each time, so that the unit lifters are powered plurally, or more than one at a time.

Each actuating means 14 is operatively engaged to each unit lifter 12, to independently move each unit lifter to engage a singulated integrated circuit. The actuating means moves the unit lifter 12 from an initial position or rest position, to a second position to engage a singulated integrated circuit. Once engaged, the actuating means then moves the unit lifter from the second position to the initial position thereby 'lifting' the singulated integrated circuit. Once all the unit lifters of a unit lifter assembly have lifted a singulated integrated circuit and moved to the initial position, the entire unit lifter assembly moves to a next location for further processing. As an example, the next location is to a visual inspection apparatus for visual inspection of the singulated integrated circuit engaged.

Typically, the final location is to a receptacle, where the unit lifters then disengage the previously engaged singulated integrated circuit for testing and/ or sorting. This process is then repeated to lift and disengage or deposit the singulated integrated circuits. To maximise the throughput of each 'lift', the present invention provides a staggered arrangement of each motor, so that the number of unit lifters per assembly is maximised whilst still maintaining a required minimum pitch between the motors. To further minimise the footprint of the unit lifter assembly, the operating stroke of the linear motor is preferably minimised so that the footprint of the machine is minimised. A linear motor drives the lateral movement of the unit lifter assembly. The actuating means in the embodiments is a rack and pinion 20 arrangement, driven by a miniature motor. The rack and pinion arrangement is shown in Figure 4.

The embodiment has been described with the use of one actuating means for one unit picker. The advantage of this configuration is that when one unit lifter 12 is faulty, the faulty unit lifter can be deactivated with only a slight reduction in the overall efficiency of the unit lifter assembly. For example, there are eighteen unit lifters 12 assembled in a unit lifter assembly 11a according to the present embodiment. One faulty unit lifter causes a 5.55% drop in the efficiency. Comparatively, in the prior art where there are four unit lifters 12 in a unit lifter assembly 11a, one faulty unit causes a 25% drop in the efficiency. In a manufacturing environment, time and hence efficiency is critical.

However, it is to be envisioned that in alternative embodiments, an actuating means can power more than one unit picker, just as long as the arrangement of the actuating means, in particular, the motors, is staggered, an alternative of which is shown in Figure 3b.

Figure 3b shows an example embodiment of the unit lifter assembly having the actuating means in a staggered arrangement where each actuating means 14 drives more than one unit lifter, specifically, as shown in Figure 3b, each actuating means drives three unit lifters.

In a typical size of a unit lifter assembly as seen in Figure 3c, the staggered arrangement allows the number of unit lifters positioned thereon, to be increased from 4 to 6. Having a same size unit lifter assembly while increasing the number of unit lifters increases throughput, and dispenses the need to modify an operating stroke of the linear motor, so  
5 that with an increased number of unit lifters, the footprint of the unit lifter assembly remains the same.

In the staggered arrangement of the present invention, adjacent motors 22 are arranged such that they are not aligned in a same horizontal axis. An example configuration is  
10 illustrated in Figure 5a, which shows a perspective view of the second embodiment. Assuming there is an arbitrary horizontal axis 30, a first miniature motor 22a is arranged below the axis 30, a second miniature motor 22b which is adjacent to the first miniature motor 22a is arranged above the axis 30, a third miniature motor 22c adjacent to the second miniature motor 22b is arranged below the axis 30, a fourth miniature motor 22d  
15 adjacent to the third miniature motor 22c is arranged above the axis 30 and so on. Figure 5b is a top view of this embodiment. From the top view, there is an overlapping of the miniature motor 22 due to the staggered order. Figure 5c is a side view of this embodiment and Figure 5d is a cross-sectional view of Figure 5c along A-A.

20 In Figure 5d, the pitch 32 between adjacent unit lifters 12 is measured from a central point of the motor to the next. The pitch 32 is proportional to the pitch between adjacent miniature motors 22. Hence, by varying the arrangement of the miniature motor 22, the pitch 32 can be varied accordingly. This is desirable so that the arrangement of the miniature motor 22 can be varied accordingly suitable for lifting integrated circuits of  
25 varying sizes. Further, Figure 5d shows how the pinions 24 are positioned in a staggered order in this arrangement, when the body 16 of the unit lifters 12 are in the same position, since the pinions 24 are in connection with the miniature motor 22.

Figures 6a, 6b, 6c, 6d shows another example of arranging the miniature motor 22 in the  
30 staggered order suitable for miniature motor 22 having 4 sides or any geometrical shape. Figure 6a shows the arrangement of the miniature motor 22 where the sides are

tilted at 45 degrees. Figures 6b, 6c and 6d illustrate the corresponding top view, side view and cross-sectional view along A-A of the top view.

This embodiment is advantageous since more unit lifters can be installed in a unit lifter assembly without increasing the footprint. Hence for the reasons previously discussed, increasing the throughput of the unit lifter assembly.

In a second embodiment, the apparatus further includes a housing 40 wherein the plurality of the unit lifters 12 are congregated. As shown in Figures 6a, 6b, 6c and 6d, the housing 40 covers at least the portion of the racks and pinions 20. Since the racks and pinions 20 operate based on the engagement of gears, the gears will have to serviced and maintained with lubrication which may contaminate the integrated circuits, affecting the reliability. Hence the need to provide a housing 40, to prevent this. In the prior art, a housing is provided for each unit lifter 12. The current embodiment of providing a housing 40 for congregating all the unit lifters 12 which firstly reduces the costs since it is more cost effective to manufacture one large housing compared to manufacturing multiple small housings, and secondly, to ease the arrangement of the miniature motor 22.

In a third embodiment, the apparatus further includes a guiding means 42 for each unit lifter 12. The guiding means 42 ensures that movement of each unit lifter 12 is aligned along the guiding means 42. The guiding means 42 can be positioned at each top and / or bottom of the housing where each unit lifter 12 is fitted. The guiding means can be a bearing guide having bearings. The bearings in the bearing guide are made of different materials dependent on the desired strength required for the bearings. In an embodiment, the guiding means 42 is in the housing 40.

For a normal operating requirement, it will be sufficient to use hardened steel bearing. Bearings can be made of other materials such as silicon carbide or ceramic. The differences in properties of the materials are listed as follows. Bearings made of silicon carbide material is stronger, wear and corrosion resistant, has low friction and a long service life. Ceramic bearings are lighter, harder and smoother in surface properties,

have better thermal properties compared to steel bearings, resists oxidation and chemical, and requires minimal or no lubrication. Alternatively, the bearing guide can be an air bearing. The air bearing is not vulnerable to wear and corrosion since there is no contact, resulting in consistent machine performance and there is no need for  
5 lubrication. The other advantages of an air bearing include a straighter, more silent and smoother motion for each unit lifter.

Preferably, in a fourth embodiment, the apparatus wherein the actuating means 14 are set external to the housing 40. Specifically, the motors having small dimensions 22 of  
10 the actuating means are set on the external of the housing 40. This allows for ease of maintenance of the miniature motor 22 without the hassle of removing the housing 40, and possibly cross contaminating the singulated integrated circuits.

In a fifth embodiment, each unit lifter 12 having an engagement means 18 at one end in  
15 the form of an elongated conduit 50 having an aperture at one end 52 as shown in Figure 7. A pump is provided to maintain the conduit in a vacuum. The vacuum force lifts a singulated integrated circuit to the engagement means. The conduit 50 minimises the contact between the engagement means and the integrated circuits. This is advantageous because the integrated circuits are susceptible to contamination when  
20 handled directly. Contamination will lead to reliability problems with the integrated circuits, so contact must be minimised. An example of an engagement means 18 is a needle of a syringe used for injections.

In a sixth embodiment of the unit lifter, the engagement means 18 in the form of a  
25 conduit and aperture at one end further includes a pad 54 attached to the aperture 52 as shown in Figure 7. The pad 54 provides a wider area of force to a singulated integrated circuit so as to prevent damage to the integrated circuits, and to provide better vacuum sealing between the pad 54 and the aperture 52, which are engaged in this embodiment. The pad 54 is further illustrated in Figure 8, which shows a perspective view of the  
30 preferred embodiment of the invention. In a preferred embodiment, the pad 54 is made of any resilient material, for e.g. rubber or foam. Advantageously, a resilient pad will provide a better seal between the aperture and pad 54.

Preferably, the frame 54 provided is suitable for lifting the integrated circuits by the edges. There will be no contact with the surface of the integrated circuits where devices are formed. This further minimises the chances of contamination.

**CLAIMS**

1. A unit lifter assembly for lifting singulated integrated circuits singulated from a semiconductor substrate including
  - 5 a. a plurality of rows and columns of unit lifters; and
  - b. a plurality of actuating means, each operatively engaged to at least one unit lifter, wherein each actuating means is arranged staggered one after another so that a pitch from one actuating means to another is minimised.
- 10 2. A unit lifter assembly according to claim 1, wherein the actuating means is configured so that adjacent actuating means are not along a same arbitrary horizontal axis.
- 15 3. A unit lifter assembly according to claims 1 or 2, wherein each actuating means is operatively engaged to each unit lifter so that each unit lifter is powered individually.
4. A unit lifter assembly according to claims 1 or 2, wherein each actuating means is operatively engaged to a plurality of unit lifters so that the unit lifters are powered plurally.
- 20 5. A unit lifter assembly according to any one of the preceding claims, wherein the actuating means is a miniature motor and a rack and pinion assembly.
- 25 6. A unit lifter assembly according to any one of the preceding claims, wherein the unit lifter has an engagement means at one end to engage a singulated integrated circuit.
- 30 7. A unit lifter assembly according to claim 6, wherein the engagement means is a conduit having an aperture at one end, the conduit being provided with vacuum so that when in use, a singulated integrated circuit is lifter via the vacuum force through the aperture.

8. A unit lifter assembly according to claim 7, wherein the engagement means further includes a pad to provide a wider area of vacuum force to a singulated integrated circuit so as to prevent damage to the engaged integrated circuit and to provide better vacuum sealing.

5

9. A unit lifter assembly according to any one of claims 6 to 8, wherein the engagement means is a needle of a syringe.

10. A unit lifter assembly according to claim 9, wherein the assembly further including a guiding means for each unit lifter.

10

11. A unit lifter assembly according to any one of the preceding claims, wherein the assembly further includes a housing wherein the plurality of unit lifters are congregated.

12. A unit lifter assembly according to any one of claims 10 or 11, wherein the guiding means is in the housing.

15

13. A unit lifter assembly according to claim 11, wherein the actuating means are set on an external of the housing.

20

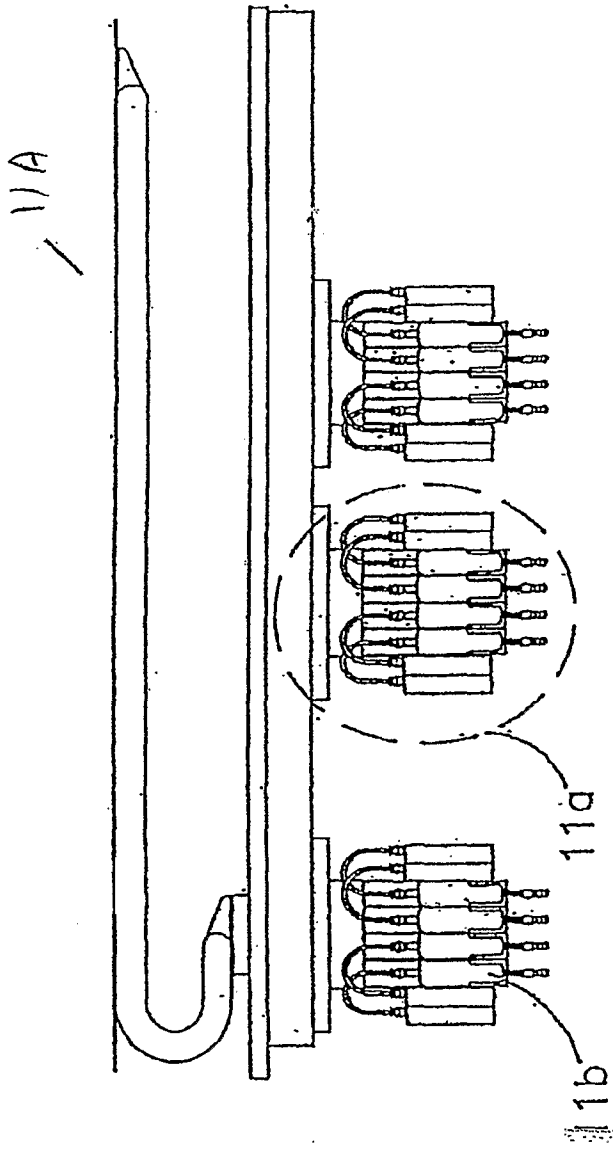

Figure 1 (Prior Art)

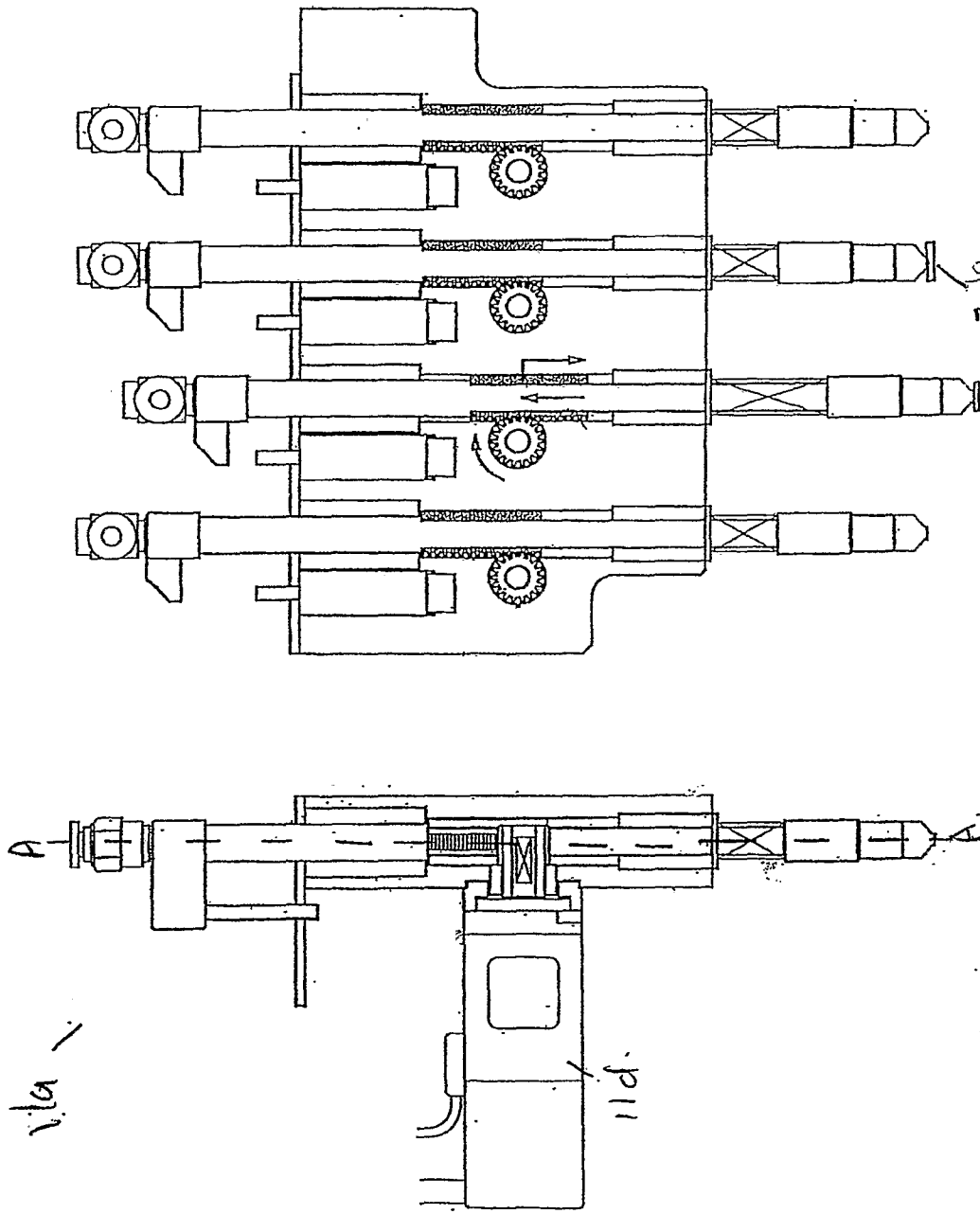

Fig 2b

Fig 2a

(Prior Art)

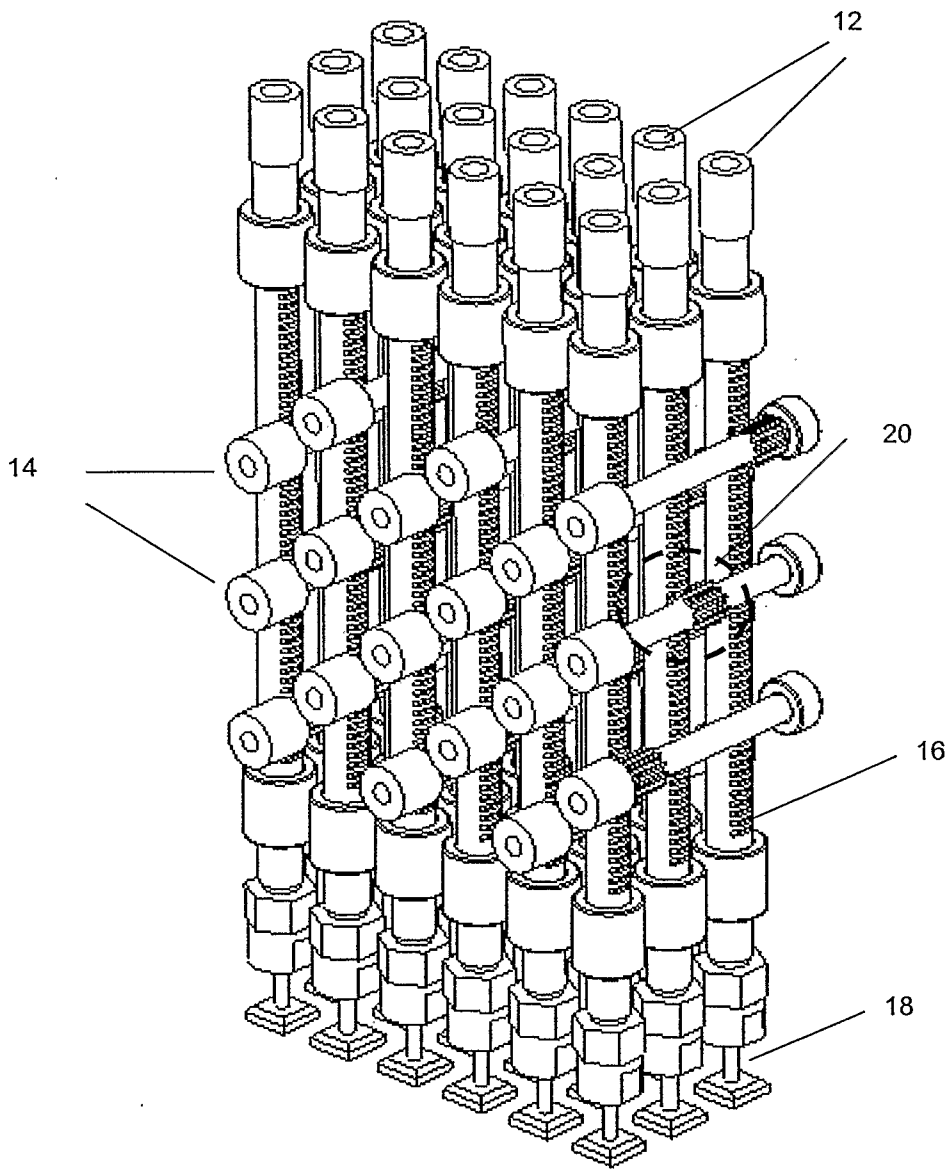

Figure 3a

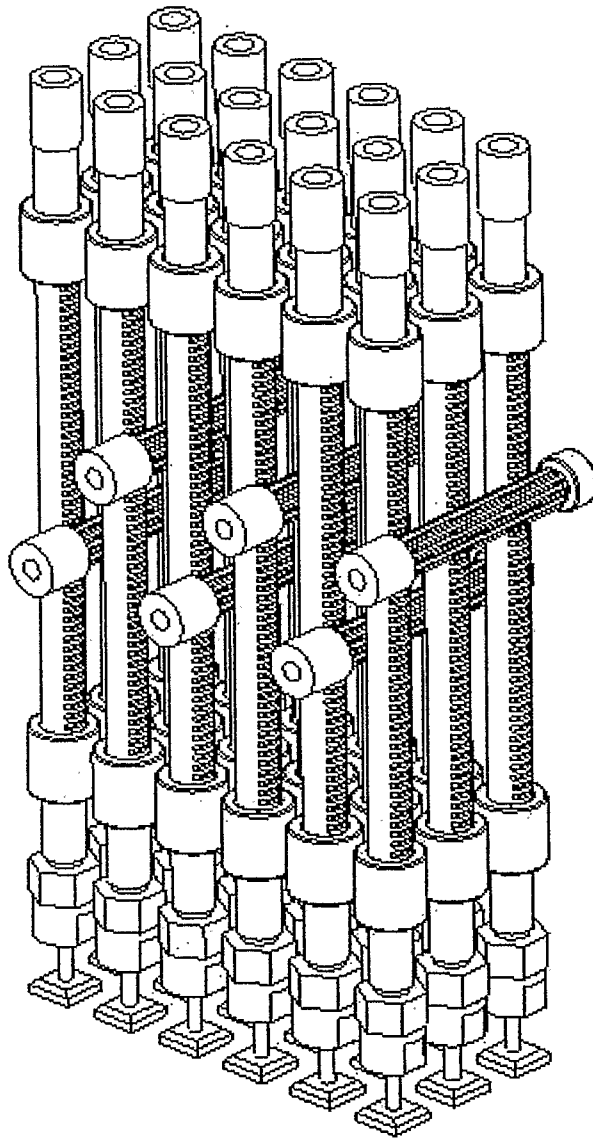

Figure 3b

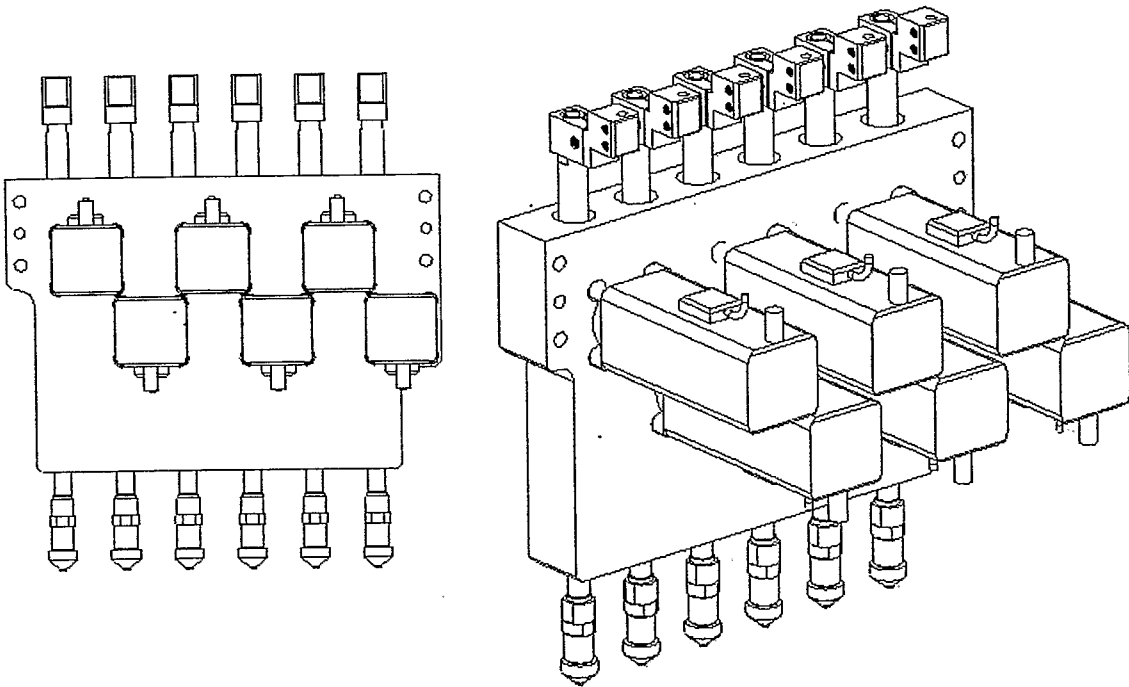

Figure 3c

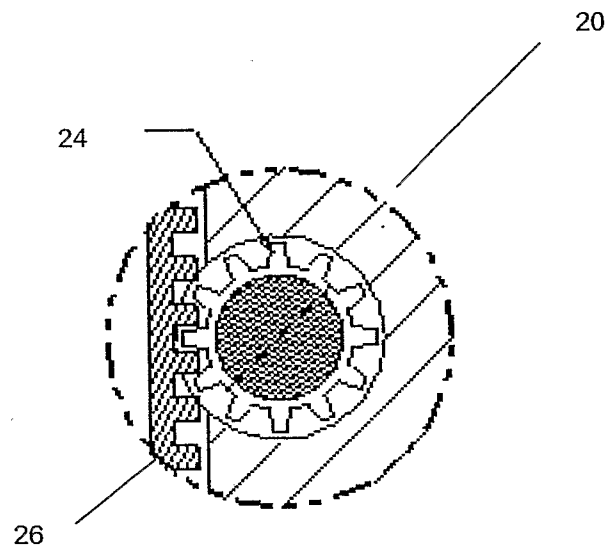

Figure 4

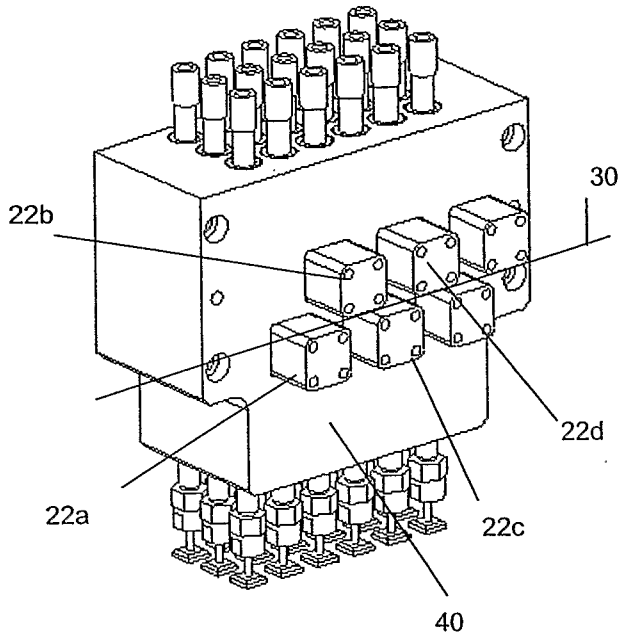

Figure 5a

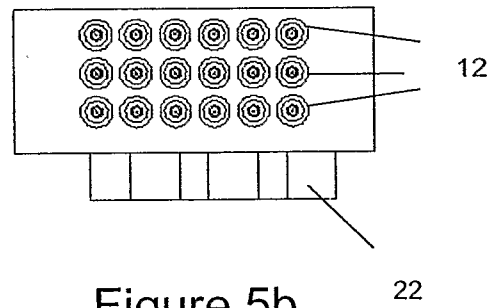

Figure 5b

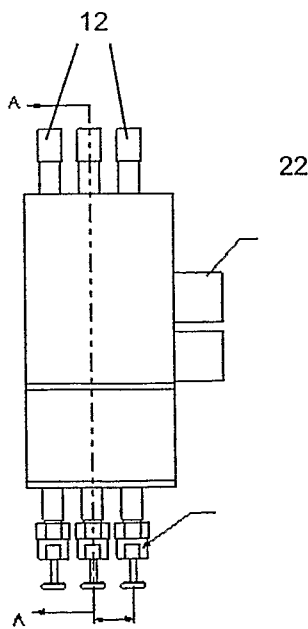

Figure 5c

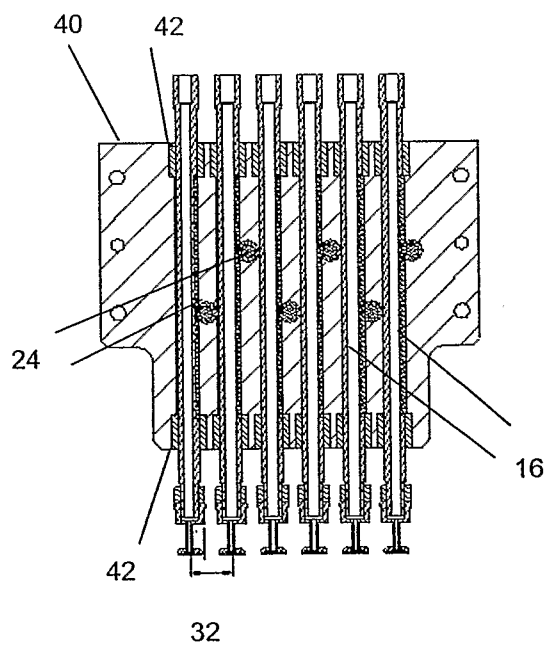

Figure 5d

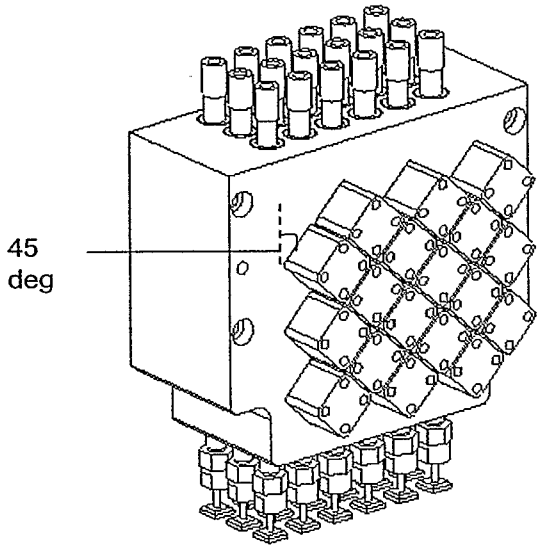

Figure 6a

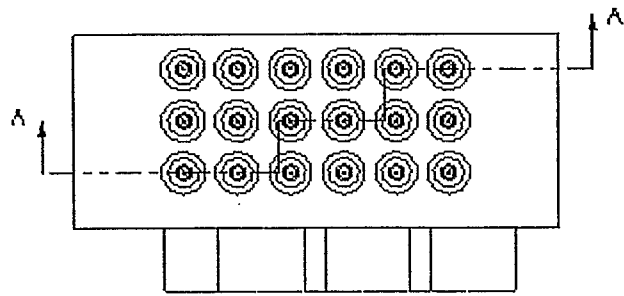

Figure 6b

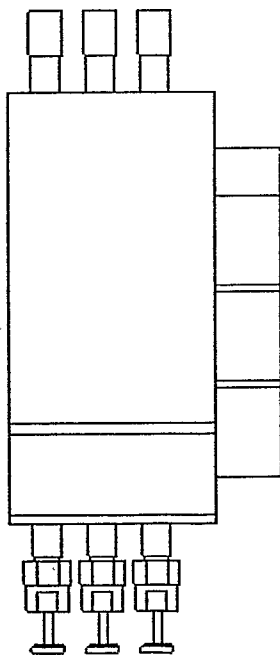

Figure 6c

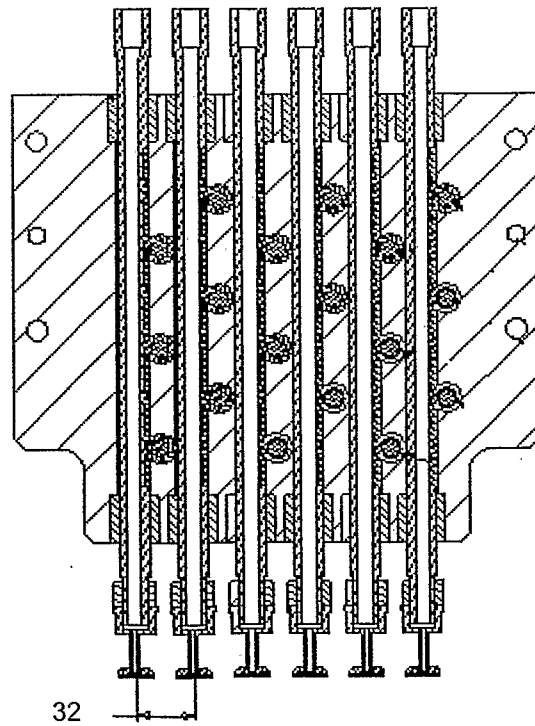

Figure 6d

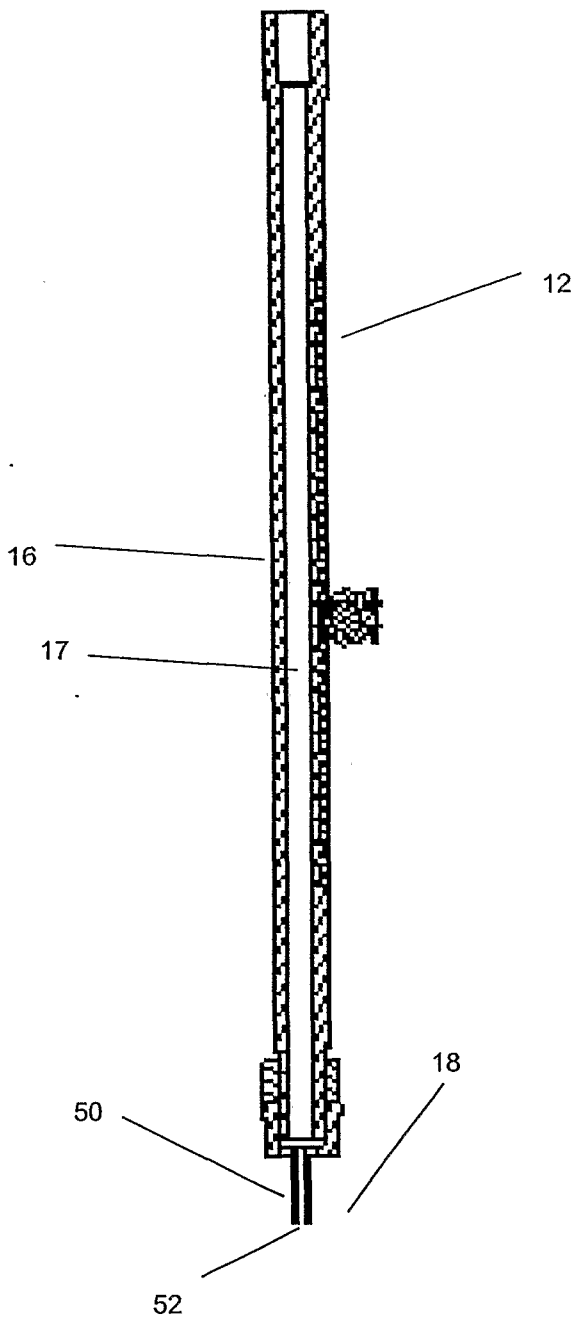

Figure 7a

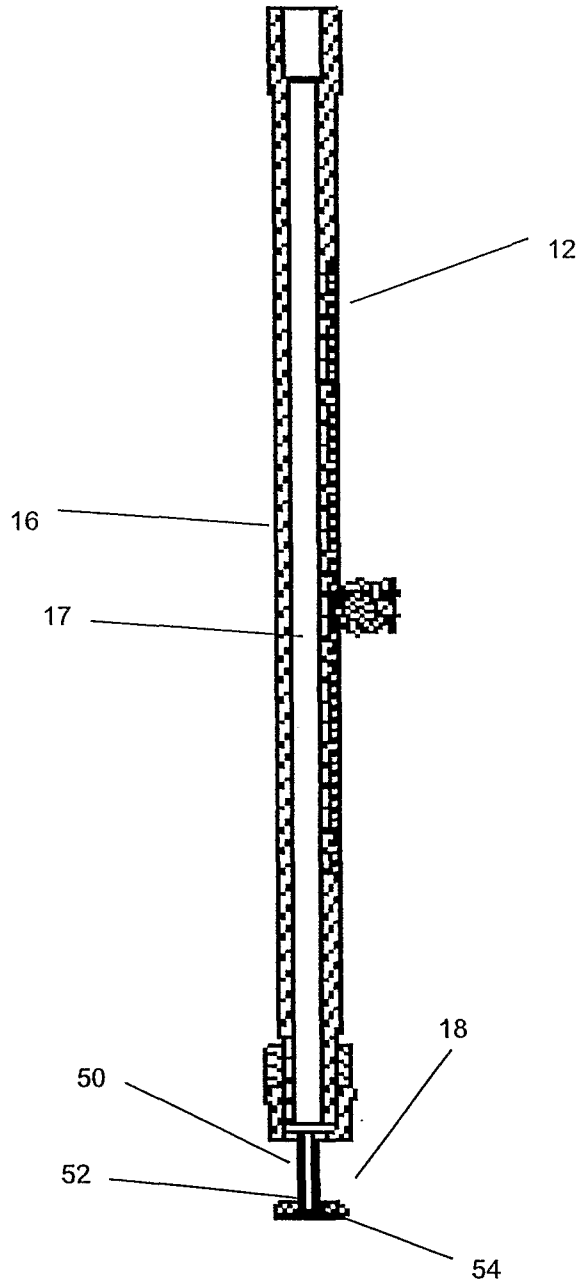

Figure 7b

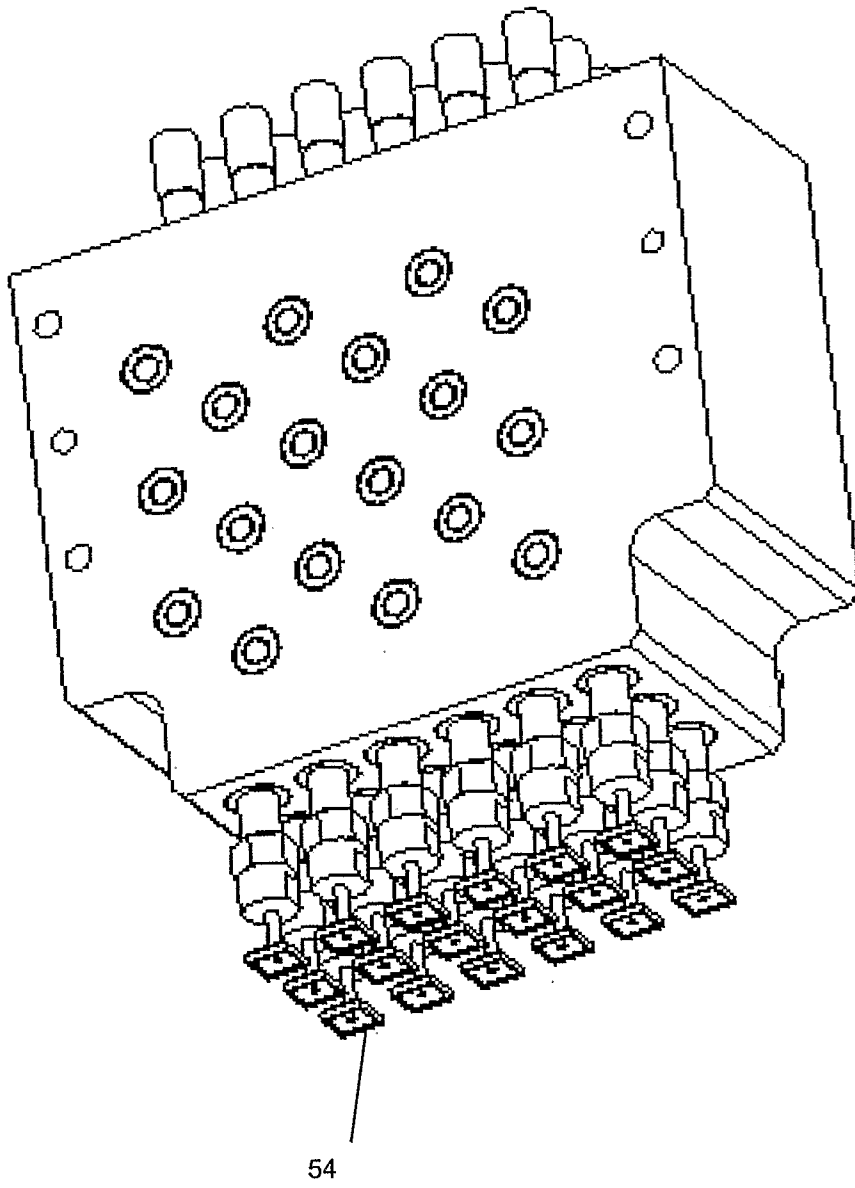

Figure 8