

(12) INTERNATIONAL APPLICATION PUBLISHED UNDER THE PATENT COOPERATION TREATY (PCT)

(19) World Intellectual Property Organization
International Bureau



(43) International Publication Date
19 September 2002 (19.09.2002)

PCT

(10) International Publication Number
WO 02/072417 A2

- (51) International Patent Classification⁷: **B63H** (74) Agent: SLATTERY, James, M.; Birch, Stewart, Kolasch & Birch, LLP., P.O. Box 747, Falls Church, VA 22040-0747 (US).
- (21) International Application Number: PCT/US02/07224
- (22) International Filing Date: 12 March 2002 (12.03.2002) (81) Designated State (national): AU.
- (25) Filing Language: English (84) Designated States (regional): European patent (AT, BE, CH, CY, DE, DK, ES, FI, FR, GB, GR, IE, IT, LU, MC, NL, PT, SE, TR).
- (26) Publication Language: English
- (30) Priority Data: 60/274,665 12 March 2001 (12.03.2001) US
Published:
— without international search report and to be republished upon receipt of that report
- (71) Applicant and
(72) Inventor: COLES, Charles, F. [US/US]; P.O. Box 484, 24, Main Street, Wenham, MA 01984 (US).
For two-letter codes and other abbreviations, refer to the "Guidance Notes on Codes and Abbreviations" appearing at the beginning of each regular issue of the PCT Gazette.



WO 02/072417 A2

(54) Title: POWERED BOAT HULL

(57) Abstract: A hydrofoil craft, particularly a method of economically modifying a conventional hull with cambered foils to obtain and calculate increased lift from dense spray and to achieve enhanced craft performance is disclosed. The present invention improves speed, fuel efficiency and rough water stability, reduced pitch and vertical accelerations. A catamaran or V-bottom hull (20) is modified with chine mounted aerofoils (32, 33, 28, 28A), flexible dihedral cambered foils positioned beneath the water line and on either side of the bow (30, 31) so as to create turbulence in the forward end of a tunnel(s) (26). Fixed forward tunnel cambered foil(s) (28) and/or fixed or adjustable center tunnel cambered foils at the stern (28A) end of the tunnel (26) to generate lift from pressure caused by dense spray in the tunnel(s) (26) may also be provided.

POWERED BOAT HULL

CROSS-REFERENCES TO RELATED APPLICATIONS

[0001] This nonprovisional application claims priority under 35 U.S.C. § 119(e) on U.S. Provisional Application No. 60,274,665, entitled Powered Boat Hull, and filed on March 12, 2001, the entirety of which is herein incorporated by reference.

BACKGROUND OF THE INVENTION

FIELD OF THE INVENTION

[0002] The present invention is related to waterborne craft, and more particularly to the use of flexible adjustable cambered foils to obtain a very high ratio of speed to horsepower by enhancing lift, performance and stability in rough water in a hydrofoil craft. The present invention is particularly applicable to all types of watercraft including, but not limited to v-bottom and catamaran boat hulls incorporating hydrofoils.

DESCRIPTION OF THE BACKGROUND ART

[0003] A conventional, modified boat hull and method of modifying the boat hull have been described in United States Patent Nos. 4,896,621 and 4,951,591 to Coles, the entirety of each of which is hereby incorporated by reference. The inventions of Coles have been described to obtain enhanced lift and rough water stability for vessels.

[0004] The method includes defining or modifying with chine aerofoil skirts an axial tunnel(s) intermediate the bow and transom of the boat hull, positioning

flexible dihedral foils below the water line and on the bow so as to obstruct and create turbulence in the forward end of the tunnel while cushioning and lifting the bow. Simultaneously, the transom end of the tunnel is enclosed with stern foils so as to compress said turbulence and thereby lift the transom.

[0005] The following references generally describe the related art and are related to the aforementioned technology, specifically U.S. Patent Nos. 2,989,279 (Le Bel); 3,763,811 (Danahy); 3,117,545 (Warner); 4,237,810 (Westfall); 3,117,347 (Cohen et al.); 4,523,526 (Smoot); 3,131,436 (Lathers et al.); 4,606,291 Hoppe; 3,221,697 (Allegretti); 4,649,851 (April); 3,357,390 (Wray); 4,665,853 (Gerdsen et al.); 3,372,663 (Lo Bue); 4,715,304 (Steinberg); 3,424,120 (Koriagin); 4,496,621 (Coles); 3,477,400 (Walker); 4,951,591 (Coles); and 3,604,384 (Coles). Foreign Patent Documents 477050 (Australia), 124594 (New Zealand), and 1421624 (France) are also related to the background of the invention.

[0006] The present inventor has discovered that there are numerous shortcomings with the related art that, as overcome by the present invention, will result in superior vessel design to obtain a very high ratio of speed to horsepower by enhancing lift, performance and stability in rough water, particularly with respect to a hydrofoil craft.

SUMMARY OF THE INVENTION

[0007] The present invention overcomes the shortcomings associated with the background art and achieves other advantages not realized by the background art.

[0008] An aspect of the invention is to provide a method of modifying and designing a boat hull to obtain and calculate enhanced lift, performance and rough water stability. The method to obtain enhanced performance includes defining or

modifying with chine aerofoil skirts and axial tunnels intermediate the bow and transom of the boat hull, positioning flexible dihedral cambered foils below the waterline and on the bow so as to create a turbulence in the forward end of the tunnel. This turbulence mixes water and air to generate a dense spray that lifts the bow while cushioning shock. The method may also include positioning fixed or adjustable cambered foils at the stern end of the tunnel to generate lift from the dense spray in the tunnels. Alternatively, or in conjunction with the other foil arrangements, the method may include enclosing the transom end of the tunnels with a rigid adjustable cambered airtight foil to compress dense spray, lift the transom and dampen pitch to prevent the bow from diving in a rough sea.

[0009] The aforementioned method is particularly advantageous in creating a hydrofoil system for a modified hull in order to obtain excellent stability and performance at high speeds in rough water as a result of substantial lift. The present invention creates hydrodynamic lift from the twin swept back surface piercing flexible forward cambered hydrofoils. Hydrodynamic lift from tunnel(s) on a catamaran hull or a V bottom hull modified with chine-mounted aerofoils, tunnel mounted cambered foils and/or stern cambered foils is also created by compressing the flow of dense spray at a high velocity with the cambered tunnel(s) and stern foil(s). Lift is created in the tunnel cambered foil(s), on the chine mounted aerofoils and stern cambered foils from the high velocity, dense spray when the transom end of the tunnels is restricted by the stern cambered foil(s).

[0010] Another aspect of the present invention includes a method for calculating the amount of enhancement of performance from modifying the boat with the cambered bow, tunnel and stern foils, comprising (a) defining before modification the boat height above water, trim, wetted surface, drag and weight vs horsepower and

speed; (b) defining modifications of bow, forward, center and stern cambered foils; (c) defining cambered foil lift; (d) defining cambered foil drag; (e) defining after modification of cambered foils hull lift; (g) defining speed vs horsepower before and after modification.

[0011] The substantial lift generated by the dense spray and the foil system of the present invention reduces the rough water wave profile impacted by the hull, so as to reduce the wave shock and improve hull stability and performance at high speeds. Accordingly, the present invention reduces power requirements and hull structural strength and weight minimum requirements.

[0012] Another aspect of the present invention is the implementation of a watercraft trim control system that effectively and safely contributes to craft operation. Trim changes of the engine shaft change the angle of attack of the bow cambered foils and raise or lower the bow. Raising or lowering the rigid airtight cambered stern foils raises or lowers the stern. Trim control of the hull is essential to reduce the danger of pitching up or down at high speeds in a rough sea.

[0013] An additional aspect of the present invention is directed toward a hydrofoil craft, particularly a method of economically modifying a conventional hull with cambered foils to obtain and calculate increased lift from dense spray and enhanced performance. The present invention improves speed, fuel efficiency and rough water stability, reduced pitch and vertical accelerations. The method of obtaining enhanced performance is characterized by defining an axial tunnel(s) intermediate the bow and transom of a catamaran hull or a V-bottom hull modified with chine mounted aerofoils; positioning flexible dihedral cambered foils beneath the water line and on either side of the bow so as to create a turbulence in the forward end of the tunnel that mixes water and air to generate a dense spray that lifts the bow

while cushioning shock. Fixed forward tunnel cambered foil(s) and/or fixed or adjustable center tunnel cambered foils positioned at the stem end of the tunnel to generate lift from pressure caused by dense spray in the tunnel(s) are also included in the present invention. The present invention may also include simultaneously or alternatively enclosing the transom end of the tunnel(s) with a rigid adjustable, vertically and or in angle of attack, cambered foils to compress the dense spray and lift the transom.

[0014] These and other aspects of the invention are specifically accomplished by a boat hull comprising a bow and a stern; a waterline extending between the bow and the stern; at least one tunnel extending axially in a direction from the bow toward the stern and having a forward end, a center region and an aft end; a pair of flexible cambered foils, the flexible cambered foils supported on sides of the bow beneath the water line, the flexible cambered foils being capable of controlling a flow within the at least one tunnel and creating a dense spray in an end of the tunnel while cushioning shock and lifting the bow; and at least one fixed, cambered foil at the after or the forward end of the at least one tunnel generating lift from a pressure being generated by the dense spray within the at least one tunnel.

[0015] These and other aspects of the invention are also accomplished by a boat hull comprising a bow and a stern, the stern including a transom; a waterline extending between the bow and the stern; a pair of tunnels extending axially in a direction from the bow toward the stern and having a forward end, a center region and an aft end; a pair of flexible cambered foils, the flexible cambered foils supported on sides of the bow beneath the water line, the flexible cambered foils being capable of controlling a flow within the at least one tunnel and creating a dense spray in an end of the tunnel while cushioning shock and lifting the bow; and at least one pair of

cambered tunnel foils at the after or forward ends of the tunnels, respectively, wherein each of the tunnels includes a respective tunnel foil generating lift from a pressure being generated by the dense spray within the at least one tunnel.

[0016] Further scope of applicability of the present invention will become apparent from the detailed description given hereinafter. However, it should be understood that the detailed description and specific examples, while indicating preferred embodiments of the invention, are given by way of illustration only, since various changes and modifications within the spirit and scope of the invention will become apparent to those skilled in the art from this detailed description.

BRIEF DESCRIPTION OF THE DRAWINGS

[0017] The present invention will become more fully understood from the detailed description given hereinafter and the accompanying drawings which are given by way of illustration only, and thus are not intended to limit the present invention to the embodiments shown, and wherein:

[0018] FIG. 1 is a side perspective view of a catamaran hull modified according to an embodiment of the present invention;

[0019] FIG. 2 is a rear elevation view of the catamaran hull of FIG. 1;

[0020] FIG. 3 is a front elevation view of the catamaran hull of FIG. 1;

[0021] FIG. 4 is a partial, exploded, front sectional view, showing the fitting of twin flexible cambered foils adjacent to a bow of a boat according to the present invention;

[0022] FIG. 5 is a fragmentary rear elevation view showing a stern cambered foil, rigid hovercraft type skirt according to an embodiment of the present invention;

[0023] FIG. 6 is a fragmentary side elevation view showing a rigid adjustable cambered foil hovercraft type skirt;

[0024] FIG. 7 is a fragmentary side elevation view showing a tunnel with a center adjustable cambered foil and a rigid adjustable, cambered stern foil having a forward end in the tunnel according to an embodiment of the present invention;

[0025] FIG. 8 is a fragmentary side elevation view showing a tunnel with a forward, fixed cambered foil, a tunnel center adjustable cambered foil, and a rigid adjustable cambered stern foil;

[0026] FIG. 9 is a rear elevation view of a twin tunnel hull construction having a single rear engine according to an embodiment of the present invention;

[0027] FIG. 10 is a rear elevation view of a twin tunnel hull construction having a dual rear engine according to an embodiment of the present invention;

[0028] FIG. 11 is a rear elevation view of a modified twin tunnel construction having a single rear engine according to an embodiment of the present invention;

[0029] FIG. 12 is a rear elevation view of a hull having a single tunnel with twin engines according to an embodiment of the present invention;

[0030] FIG. 13 is a partial, side elevation view, partially in phantom of the catamaran hull of FIG. 1 having pairs of bow, forward and center tunnel, and stern cambered foils according to an embodiment of the present invention;

[0031] FIG. 14 is a fragmentary sectional view showing the fitting of cambered foils adjacent the bow, forward in the tunnel, aft in the tunnel and at the stern in a position intersecting the tunnel according to an embodiment of the present invention;

[0032] FIG. 15 is a longitudinal sectional view of the boat hull of the present invention shown in FIG. 13 underway at relatively low speeds;

[0033] FIG. 16 is a longitudinal sectional view showing the boat hull of the present invention shown in FIG. 13 underway at high speed with a stern foil closed so as to compress the dense spray within a tunnel;

[0034] FIG. 17 is the rear elevation view of the boat shown in FIG. 16;

[0035] FIG. 18 is a schematic exploded view of the boat shown in FIGs. 13, 15 and 16, and having the pairs of bow foils, forward tunnel foils, center tunnel foils and stem foils;

[0036] FIG. 19 is a fragmentary side elevation view of a flexible cambered bow foil according to an embodiment of the present invention;

[0037] FIG. 20 is a bottom plan view of the cambered foil shown in FIG. 19;

[0038] FIG. 21 is a fragmentary end elevation view of an embodiment having a bow foil positioned on a V-bottom boat hull;

[0039] FIG. 22 is a schematic view of the of shims or hydraulic means to adjust the angle of attack (α) of a cambered bow foil according to the present invention;

[0040] FIG. 23 is a side elevation view of a twin tunnel hull having bow cambered foils, forward tunnel cambered foils, center tunnel cambered foils and a pair of stern cambered foils according to an embodiment of the present invention;

[0041] FIG. 24 is a plan view of the hull shown in FIG. 23;

[0042] FIG. 25 is a side elevation view of a V-bottom or rigid inflatable hull modified with a chine aerofoil skirt to define axial tunnels influenced by the cambered bow foils, cambered center tunnel foils and cambered adjustable stern foils;

[0043] FIG. 26 is a rear elevation view of the V-bottom hull shown in FIG. 25;

[0044] FIG. 27 is a plan view of the V-bottom hull shown in FIG. 25;

[0045] FIG. 28 is a partial, side elevation view of the V-bottom hull shown in FIG. 25, demonstrating compression of tunnel turbulence and dense spray by stern foils.

[0046] FIG. 29 is a rear view of the boat hull shown in FIG. 23; and

[0047] FIG. 30 is a side view according to an embodiment of the present invention.

DETAILED DESCRIPTION OF THE PREFERRED EMBODIMENTS

[0048] The present invention will hereinafter be described with reference to the accompanying drawings. Hereinafter, the present invention will be described in detail with reference to the accompanying drawings. The present invention is an improvement over previous waterborne craft hulls available in the related art. The details and arrangements found in U.S. Pat. No. 4,896,621, U.S. Pat. No.4,951,591, and U.S. Pat. No. 3,604,384 all to the inventor of the present invention Coles, are hereby incorporated in their entirety by reference into the present application.

[0049] Although the present invention is directed toward any waterborne craft, boat, ship or other type of vessel, the following description will employ the use of the terms boat and hull for simplicity. In addition, one of ordinary skill in the art will appreciate that the following description relies upon terms generally understood in the related art, including but not limited to forward, stem, bow, stern, transom, camber, lift, starboard, port and waterline(s). One of ordinary skill in the art will appreciate that a waterline is typically the line of the water's edge when a waterborne craft is afloat, technically the intersection of any horizontal plane with the molded form of the ship. In practice, the designer anticipates the preferred operation of the vessel and the positioning of the waterline based upon vessel dimension, loading sea state, etc.

[0050] The present invention is particularly suited to a catamaran type of hull readily fabricated from metal or molded plastic material and modified to include a tunnel(s) defined between two hull sections or pontoons. Alternatively, the present invention is equally applicable to a V-bottom type of hull having pairs of cambered foils fore-and-aft adapted to be acted upon both by a water stream and a dense spray in order to assist in lifting the hull when the boat is under power. One of skill in the art will appreciate that variations and/or combinations including features of both V-bottom and catamaran hulls are anticipated by the present invention.

[0051] As aforementioned, the bow foils on the bow of a boat may be formed as surface piercing cambered hydrofoils and shaped so that they cooperate in creating turbulence, e.g., in the form of a dense spray in a flow stream passing thru the tunnel(s) while assisting in increasing the lift of the hull which is largely out of the water when the boat is traveling at a relatively high speed. A highly desirable combination of lift and stability may be provided by various combinations of bow surface piercing cambered hydrofoil(s), forward fixed tunnel cambered foil(s) and/or center fixed or adjustable tunnel cambered foil(s) and adjustable, rigid, airtight, cambered foil(s) applied to a hovercraft skirt or hull. A catamaran hull embodiment and a v-bottom hull or rigid inflatable hull embodiment of the present invention will be described hereinafter in greater detail with reference to the accompanying drawings.

Catamaran Hull Embodiment

[0052] FIG. 1 is a side perspective view of a catamaran hull modified according to an embodiment of the present invention. FIG. 2 is a rear elevation view of the catamaran hull of FIG. 1. FIG. 3 is a front elevation view of the catamaran hull

of FIG. 1. FIG. 4 is a partial, exploded, front sectional view, showing the fitting of twin flexible cambered foils adjacent to a bow of a boat according to the present invention. FIG. 5 is a fragmentary rear elevation view showing a stern cambered foil, rigid hovercraft type skirt according to an embodiment of the present invention. FIG. 6 is a fragmentary side elevation view showing a rigid adjustable cambered foil hovercraft type skirt. FIG. 7 is a fragmentary side elevation view showing a tunnel with a center adjustable cambered foil and a rigid adjustable, cambered stern foil having a forward end in the tunnel according to an embodiment of the present invention. FIG. 8 is a fragmentary side elevation view showing a tunnel with a forward, fixed cambered foil, a tunnel center adjustable cambered foil, and a rigid adjustable cambered stern foil, wherein the center and stern foils may be adjusted by a hydraulic jack and trim plate mounted on a vessel transom.

[0053] FIGS. 1, 2, 3 and 13 show a catamaran hull 20 having integral port and starboard pontoons 23, 24, respectively. The hull 20 may be fabricated or molded integrally of a plastic material conventionally known in the related art for boat hulls, such as polyurethane and/or its equivalents. Regardless of the mode of construction, the pontoons 22 and 24 form between them an axial tunnel 26. The axial tunnel 26 may include fixed or adjustable cambered center foils 28, cooperatively associated with pairs of bow flexible cambered foils 30, 31, and a pair of adjustable, rigid, cambered stern foils 32, 33. The form, function and mode of operation of the bow foils 30, 31, center foils 28 and stern foils 32, 33 are explained in greater detail hereinafter.

[0054] The hull 20 may include an open cockpit 34, furnished with a windshield 36. At the rear of the cockpit 34, a transom 38 for closing the cockpit 34 and reinforced to support an outboard motor 39 and/or alternatively an inboard,

outboard drive or jet drive of reasonably small power for speeds which are obtained in rough water is also provided. As shown in all views, bow port 30 and bow starboard cambered foils 31, 31 are separately attached, e.g. with bolts, to exterior pontoon surfaces.

[0055] Similarly forward and center tunnel cambered foils 28, 28A, and aft port 32 and aft starboard cambered foils 33 are individually secured to the hull in similar manners. As shown in FIG. 4, a preferred embodiment indicates that the starboard cambered foil assembly 31 may include a main cantilevered, flexible cambered metal foil 40, a rubber shock pad 41 to reduce shock and fatigue of the metal foil 40, reinforcing material 42 in the starboard pontoon 24, a bolt plate 43, and a bolt and lock nut assembly 44. In addition, the foil assembly 31 may include a channel 45, rubber shock pad 46, a lower cantilevered flexible cambered foil 47, rubber shock fence 48 for added directional stability and seating of a second bolt and lock nut assembly 49. The bolt assemblies 44, 49 allow the entire foil assembly or only the lower foil 47 and fence 48 to be easily removed for replacement and/or repair. The cambered foils 40 and 47 bend in torsion, and therefore may be replaced with larger or smaller foils depending on individual hull requirements for higher speed or rough water operation.

[0056] FIG. 5 shows a stern cambered foil 32 that can be raised or lowered by hydraulic or pneumatic rams 50. For example, when the boat is traveling at high speeds into surface winds, the density of the spray, pressure and lift is reduced under the forward and/or center tunnel cambered foils 28, 28A when the stern cambered foil 32 in the form of a hovercraft skirt is raised. When foil 32 is lowered, the density of the spray, pressure and lift is increased on the forward and or center tunnel foil 28, 28A and stern foils 32 and 33.

[0057] As shown in FIG. 6, stern foils 32 and 33 are attached to hull pontoons 22 and 24 with a gasket 51 held in place with a clamp 52 to prevent air escaping between the stern foil 32, center foil 28 and hull pontoon 22. Increasing hull lift by lowering stern foil 32 reduces shock when traveling into the wind in rough water, accordingly demonstrating an increased wave frequency and profile. The design of the stern foil present invention tends to prevent the foil from being lifted above the surface of the water and the propellers from cavitating during operation.

[0058] FIG. 7 shows an alternate design with the forward end of the cambered stern foil 32 in the tunnel, with gasket 51 preventing the spray from escaping between the fixed center tunnel cambered foil 28, stem cambered foil 32 and the sides of the tunnel. FIG. 8 shows a stern bracket 50A that can be adjusted upwardly and downwardly to raise or lower the stern cambered foil 32 and the center cambered tunnel foil 28. The trim angle of the cambered stern foil can also be adjusted with the present invention. Gasket 51 prevents spray from escaping between the adjustable center cambered tunnel foil 28 and the adjustable stern cambered foil 32. Gasket 51A prevents the spray from escaping between the fixed forward cambered tunnel foil 28A and the adjustable center cambered tunnel foil 28.

[0059] FIG. 9 is a rear elevation view of a twin tunnel hull construction having a single rear engine according to an embodiment of the present invention. FIG. 10 is a rear elevation view of a twin tunnel hull construction having a dual rear engine according to an embodiment of the present invention. FIG. 11 is a rear elevation view of a modified twin tunnel construction having a single rear engine according to an embodiment of the present invention. FIG. 12 is a rear elevation view of a hull having a single tunnel with twin engines according to an embodiment of the present invention. FIG. 13 is a partial, side elevation view, partially in phantom of the

catamaran hull of FIG. 1 having pairs of bow, forward and center tunnel, and stern cambered foils according to an embodiment of the present invention.

[0060] FIG. 9 shows rear cambered foils 32 and 33 and center cambered tunnel foils 28 mounted on a twin tunnel hull 20 powered by a single engine 39. FIG. 10 shows foils 32, 33 and 28 mounted on a twin tunnel hull 20 powered by two engines 38, 39, and FIG. 12 shows a single stern foil 32 and single center tunnel foil 28 mounted on a single tunnel hull 20 having two engines 38, 39. FIG. 11 shows foil 32, 33 and 28 mounted on a twin tunnel hull with a single engine and relatively larger tunnels 26.

[0061] FIG. 14 is a fragmentary sectional view showing the fitting of cambered foils adjacent the bow, forward in the tunnel, aft in the tunnel and at the stern in a position intersecting the tunnel according to an embodiment of the present invention. FIG. 15 is a longitudinal sectional view of the boat hull of the present invention shown in FIG. 13 underway at relatively low speeds. FIG. 16 is a longitudinal sectional view showing the boat hull of the present invention shown in FIG. 13 underway at high speed with a stern foil closed so as to compress the dense spray within a tunnel. FIG. 17 is the rear elevation view of the boat shown in FIG. 16. FIG. 18 is a schematic exploded view of the boat shown in FIGs. 13, 15 and 16, and having the pairs of bow foils, forward tunnel foils, center tunnel foils and stem foils. The turbulence and dense spray created by the bow foils and the compression of this turbulence in the tunnels and by the tunnel foils and stern foils enclosing the tunnels, is illustrated by increasing bubble density at the after end of the flow stream. FIG. 19 is a fragmentary side elevation view of a flexible cambered bow foil according to an embodiment of the present invention. FIG. 20 is a bottom plan view of the cambered foil shown in FIG. 19.

[0062] As illustrated in FIGs. 13 to 16, the bow cambered foils 30, 31, the air tight tunnel forward and center cambered foils 28,28A and air tight stern cambered foils 32 ,33 cooperate with the tunnel 26 to provide lift to the hull generated by water and dense spray. The water and air generated in part by the bow foils 30, 31 combine to form the dense spray that provides pressure that gives lift to the cambered foils. Pressure data was obtained from during sea trials by using pitot tubes to determine the pressure on the different cambered bow 30,31, forward and center tunnel 28, 28A, and stern foils 32, 33. Lift and drag of the different foils, appendages and hull were calculated by regression formulae on a computer relating pressure to spray density, speed, height above water, angle of attack, length, beam, camber and lift coefficient. Additional details of these trials and experimental results are provided in greater detail in the accompanying TABLES described hereinafter.

[0063] When the boat hull 20 is in the position shown in FIG. 16 while being operated at high speed, dense spray and waves are compressed in the rearward portion of the tunnel and stern foil, while directly and indirectly exerting an upward lifting force. The water and dense spray at large velocity being compressed by the motion of the boat between the walls of the tunnel(s) 26 in the rear and on the cambered tunnel foils 28, 28A and air tight stern foils 32, 32 exert considerable lift.

[0064] In FIG. 19, the construction of a flexible cambered forward foil 60 which is mounted upon a channel or I-beam 62, includes a camber and swept back configuration such that the foil passes over debris without damage and bends under torsion so as to reduce fatigue stress/failure from bending. The leading edge 64 of the channel or I-beam 62 is inclined downwardly and aft so as to reduce drag and a shock pad 66 is fitted intermediate the channel or I-beam 62 and the hull exterior 74 prior to fastening through bolts 68, 70 and 72. Similarly shock pad 80 may be secured

between channel or I-beam 62 and the cambered foil 60 by means of through holes 76, and 78.

V-Bottom Hull or Rigid Inflatable Hull Embodiment

[0065] FIG. 21 is a fragmentary end elevation view of an embodiment having a bow foil positioned on a V-bottom boat hull. FIG. 22 is a schematic view of shims or hydraulic means to adjust the angle of attack (x) of a cambered bow foil according to the present invention. FIG. 23 is a side elevation view of a twin tunnel hull having bow cambered foils, forward tunnel cambered foils, center tunnel cambered foils and a pair of stern cambered foils according to an embodiment of the present invention. FIG. 24 is a plan view of the hull shown in FIG. 23. FIG. 25 is a side elevation view of a V-bottom or rigid inflatable hull modified with a chine aerofoil skirt to define axial tunnels influenced by the cambered bow foils, cambered center tunnel foils and cambered adjustable stern foils. FIG. 26 is a rear elevation view of the V-bottom hull shown in FIG. 25. FIG. 27 is a plan view of the V-bottom hull shown in FIG. 25. FIG. 28 is a partial, side elevation view of the V-bottom hull shown in FIG. 25, demonstrating compression of tunnel turbulence and dense spray by stern foils. FIG. 29 is a rear view of the boat hull shown in FIG. 23. FIG. 30 is a side view according to an embodiment of the present invention.

[0066] FIG. 21 shows the placement of forward cambered foil 86 on a V-bottom hull 82 with channel or I-beam 84, and includes an angle fence 88. FIG. 22 is a schematic side view designating the angle of attack (x) of the bow cambered foil which may be adjusted by means of rubber shims or hydraulic controls (not illustrated). FIGs. 23, 24 and 29 detail a single tunnel 96 construction, having bow mounted cambered foils 94, a forward tunnel cambered foil 28A, a center tunnel

cambered foil 28 and stern cambered foils 102,104 hydraulically actuated by struts 106, 108.

[0067] Rigid hovercraft type airtight skirts 98, 100 may also be employed to enclose the transom end of the tunnel. As illustrated in FIGS. 25-29, in addition to the forward cambered foils 122 mounted beneath the V-bottom hull or rigid inflatable hull 110, it is possible to obtain even greater lift and stability from dense spray and pressure by the use of wing-like, longitudinal chine or bottom mounted air tight aerofoils 112 mounted between the chine or bottom and skeg of the hull from mid section to the stern to generate two tunnels to generate lift from the already described cambered foils.

[0068] As in the above-described construction the center tunnel cambered foil 119 may be adjustable and the stern cambered foil 118 may be actuated by hydraulic cylinder 116. Experimental testing of various aspects of the present invention indicate that unique and highly beneficial results are obtained by the aforementioned embodiments and variations thereof.

[0069] The following appendices are additionally provided and show various experimental results, test data and operational performance data according to various embodiments of the present invention. The details of which will be described in detail hereinafter.

[0070] TABLE I: Method for Calculating Performance

Three flexible cambered tunnel foils and two flexible cambered bow foils

	Cambered tunnel foils			Cambered bow foils	Hulls	Prop	Total
	Stern	Center	Fwd				
<u>A Design</u>							
Number	1	1	1	2			
Length ft.	3	5	2.7	3	7.6		
Beam aft	2	2	2	2	2.9		
Aspect ratio B/L	0.67	0.4	0.74	0.67			
Camber Cld	0.1	0.1	0.1	0.1			
Trim vs WL deg	3	3	8	3	3		
Spray flo	3	3	8				
Wetted vert.(9)	3	5.4	46.8	3			
Weight(4)							10000#
Power	2 200 hp Yamaha 400 hp@ 5500 rpm						
Propulsive horse power	400 x .6= 240 hp						240

B Performance @ 45 k

	Cambered tunnel foils			Cambered bow foils	Hulls	Prop	Total
	Stern	Center	Fwd				
Clb(1)	0.121	0.137	0.115	0.1			
Lift/drag(1)	10.2/1	9./1	9.6/1	10./1	8.84/1		
(b) Velocity 45 k- 76.01 f/s							
Pressure (2)	3508	3549	213	5742	5742		
Lift (3) Initial	1698	1944	98	4594	6084		14418
Revised	1698	1944	98	2584	3670		9994
Drag (3) Horizontal	166	213	10	258	117		764
(10) Vertical	<u>12</u>	<u>25</u>	<u>2</u>	<u>8</u>	48		95
Residual					<u>321</u>		<u>321</u>
	178	238	12	266	486		1180
Lift required	10000/9994=1.0006						
	1698	1944	98	2590	3670		10000
Drag	178	238	12	266	486		1180
Appendage (12)							94
Wind (13)							<u>437</u>
							1711

10000# Craft weight

	With foils	No foils
Speed mph	51.8	41
Propulsive HP required= velocity f/s x drag/550= 76.01x1711/550=	236 hp	240
Propulsive HP available= 2 200 HP Yamaha= 400x 6 propulsive eff =	240 hp	240
Rpm to produce 236 hp= (236/240)x 5500=	5408	5500

[0071] TABLE II: Hull/Performance Data

Foil System

(1) Clb and Lift/drag

Cambered planes

<u>Stern</u>	USN report 3147	Page 20	AR=.67. Spray flow= 3 deg. Cld= .1. Clb= .121
		Page 15	AR=.67. Spray flow= 3 deg. Clb=.121 . Lift/drag=10 2/1
<u>Center</u>	" "	Page 20	AR=.4. Spray flow= 3 deg. Cld=.1. Clb= .137
	" "	Page 3	AR=.4 Spray flow= 3 deg. Clb= .137.Lift/drag=9/
<u>Fwd</u>		Page 20	AR=.74 Spray flow= 3 deg. Cld=.1 Clb=.115
		Page 3	AR=.74 Spray flow= 3deg. Clb= .115. L/D=9.6/1
<u>Bow foils</u>	" "Page20		AR=.67. Water flow=3 deg . Cld=.1. Clb=.121 @ 0 deg rise
	" "		Clb= .10 @ 11 degree rise
		Page 15	Lift/drag=10/1

(2) Pressure

Stern plane	3508
Center plane	3549
Fwd plane	213
Bow foils	5742
Hulls	5742

45 k

(3) Lift and drag

Hulls

a= Trim 3 deg x exp1.1=3.35. Y=Length/beam=7.6/2.9=2.62. V=76.01f/s. g=32.2
 cv=V/(gB) exp.5=7.86. Cdl=[a exp 1.1(.012y exp.5+.0095y exp2/cv exp2)]=
 3.35(.0194+.065/61.77)=3.35(.0209)=.070. 0 deg foil rise Cdl=.9x.07=.063
 Lift= Cdlx pitot pressurexBxBx2=.063x5742x2.9x2.9x2=6084

Stern plane

Lift=ClbpressxBxB .121x3508x2x2=1698
 Drag=L/(L/D) 1698/10.2=166

Center plane

Lift=ClbpressxBxB .137x3549x2x2=1944
 Drag=L/(L/D) 1944/9.1=213

Fwd plane(8)

Lift=ClbpressxBxB .115x213x2x2=98
 Drag=L/(L/D) 98/9.6=10.2

Bow Foils

Lift=ClbpressxBxB .1x5742x2x2=4594
 Drag=L/(L/D) 4594/10=459

(4) Weight

Boat 4100#, engine & steering 1000#, foil system 500#, fuel 2500# 500 gal, crew 400# & Misc 500# = Total weight 9000# + 1000# additional fuel and misc.= 10000#

(5) Stern cambered plane(foil)

(a) Trim deg

1 Stern plane vs center plane	3
2 Center plane vs WL	3
3 Stern plane vs WL	6
4 Stern plane water flow	3

(b) Height

1 Stern plane pitot aft vs WL	0.15
2 Stern plane aft vs WL. Ht+.13	0.28

45 k

[0072] TABLE III: Hull/Performance Data

	<u>Foil System</u>
<u>(5) Stern cambered plane(foil)</u>	<u>45 k</u>
3 Stern plane fwd	
a Sin trimx3 sin 6x3	0.314
b.1698xlengthxCld=.1698x3x.1=	0.051
c.Stern plane aft	<u>0.28</u>
	0.645
4 Stern plane pitot fwd vs WL . Ht-.17	0.48
<u>(c) Pressure</u> .5x densityxf/sxf/s	
1 Stern plane aft pitot	
2 Stern plane fwd pitot	
3 Stern plane ave pitot	3508
<u>(d) Stern plane camber</u>	
Length 3 ft	
x= .1 .2 .3 .4 .5 .6 .7 .8 .9 1.	
x= .3 .6 .9 1.2 1.5 1.8 2.1 2.4 2.7 3.	
y= -.0001 .001 .003 .006 .010 .013 .011 .003 -.017 -.051	
 <u>(6) Center cambered plane(foil)</u>	 <u>45 k</u>
<u>(a) Trim</u> deg	
1 Center plane vs fwd plane	0
2 Center plane vs WL	3
3 Center plane vs Spray flow	3
<u>(b) Height</u>	
1 Center plane pitot aft vs WL	0.48
2 Center plane aft vs WL. Ht+.13	0.61
3 Center plane fwd	
a. Sin trimx5	0.262
b.1698xlengthxCld=.1698x5x.1=	0.085
c.Center plane aft	<u>0.61</u>
	0.96
4 Center plane pitot fwd -.17.	0.79
5 Center plane pitot ave ht.	0.64
<u>(c) Pressure</u> .5x densityxf/sxf/s	
1 Center plane aft pitot	
2 Center plane fwd pitot	
3 Center plane ave	3549
<u>(d) Center plane camber</u>	
Length 60"	
x= .1 .2 .3 .4 .5 .6 .7 .8 .9 1.	
x= 6 12 18 24 30 36 42 48 54 60	
y= .00 -.02 -.06 -.12 -.2 -.26 -.22 -.05 .34 1.02	
 <u>(7) Fwd cambered plane(foil)</u>	 <u>45 k</u>
<u>(a) Trim</u> deg	
1 Fwd plane vs WL	8
2 Fwd plane vs Spray flow	8

[0073] TABLE IV: Hull/Performance Data

		<u>Foil System</u>									
<u>(7) Fwd cambered plane(foil)</u>		<u>45 k</u>									
<u>(w) Height</u>											
1 Fwd plane pitot aft vs WL		0.64									
2 Fwd plane aft vs WL. Ht+.13		0.77									
3 Fwd plane fwd											
a. Sin trimx(2 deg)		0.105									
b. 1698xlengthxCld=.1698x3x.1=		0.051									
c. Fwd plane aft		<u>0.77</u>									
		1.87									
4 Fwd plane pitot fwd - 17		1.7									
5 Fwd plane pitot ave ht.		1.58									
<u>(c) Pressure</u>	.5x densityxf/sxf/s										
1 Fwd plane aft pitot		392									
2 Fwd plane fwd pitot		7									
3 Fwd plane ave		215									
<u>(d) Center plane camber</u>											
	Length 32.4"										
x=		1	2	3	4	5	6	7	8	9	10
x=		0	3.6	7.2	10.8	14.4	18	21.6	25.2	28.8	32.2
y=		0	-.01	-.04	-.07	-.12	-.16	-.12	-.04	.2	.61
<u>(8) Bow Foils</u>											
<u>(a) Trim fwd foils vs WL</u>		3 deg									
<u>(b) Pressure</u>		5742									
<u>Bow foil camber</u>											
	Length 3 ft										
x=		.1	.2	.3	.4	.5	.6	.7	.8	.9	1.
x=		.3	.6	.9	1.2	1.5	1.8	2.1	2.4	2.7	3.
y=		-.0001	.001	.003	.006	.010	.013	.011	.003	-.017	-.051
<u>(9) Wetted surface</u>		<u>A 45 k</u>									
		<u>Cambered planes</u>			<u>Bow</u>		<u>Hulls</u>		<u>Total</u>		
<u>Horizontal</u>	<u>Water</u>	<u>Stern</u>	<u>Center</u>	<u>Fwd</u>	<u>Foils</u>						
	Width ave										2.9
	Length										7.6
	Number										2
	Area										44.1
											44.1
<u>Vertical</u>	<u>Water</u>										
	Height ave	0.25				0.15					0.6
	Length	3				2					7.6
	Number	2				4					4
	Area	1.5				1.2					18
											24.7
	<u>Spray</u>										
	Height ave	0.25	1.6		1.8						
	Length	3	5		2.7						
	Number	2	2		2						
	Area	1.5	6		9.7						17.2

[0074] TABLE V: Hull/Performance Data

		<u>Foil System</u>
<u>(10) Vertical drag</u>		
<u>A 45k</u>		<u>45 k</u>
(a) Cf Schoenherr @ Reynolds no		76.01 f/s
Reynolds no= velocityx (length/viscosity)		
Length =26.25.		
Viscosity=@ 50 deg salt=1.46x10 exp-5		
Reynolds no=76.01x26.25/1.46x10 exp -5		1.366x10exp.+8
Cf @Rey no=1.366-(1.366-1.060)x.12/2=		1.182x10 exp-3
(b) Pitot pressure		
Lift		-10000
Water .5x64/32.2x76.01x76.01=		5742
Spray- Stern plane		3508
Center plane		3549
Fwd plane		.213
<u>(c) Frictional resistance. Cf x press x area</u>		<u>45k</u>
<u>Stern plane</u>		
Water	1.182x10 exp -3x1.5x3805	6.1
Spray	1.182x10 exp -3x1.5x3805	6.1
<u>Center plane</u>		
Spray	1.182x10 exp -3x6x3549	25.2
<u>Fwd plane</u>		
Spray	1.182x10 exp -3x9.7x213	2.4
<u>Fwd Foils</u>		
Water	1.182x10 exp -3x1.2x5742	8.1
<u>Hulls</u>		
Water Hor	1.182x10 exp -3x44.1x5742	299
Vert	1.182x10 exp -3x181x5742	121
<u>(d) Residual resistance -Tan Trimx Lift -Horizontal only</u>		
Hulls	3670x tan 5 deg=3670x.0875	321
<u>(e) Hull lift/drag</u>		
	3670/ Resistance friction & residual	
	3670/(299+321)=5.91	
<u>(11) Propeller</u>		
<u>(12) Appendage resistance</u>		<u>45 k</u>
(a) normal .04 x frictional and residual resistance= Drag		1181
Appendage resistance @8%		94
<u>(13) Wind resistance</u>		
(a) Cwx.5x.0024xvxxvxAarea		
Cw.=1.28. Area=6.2x2+8.3x2.75+4x3.5=49.250		
1.28x49.3x.5x.0024x76.01x76.01=		437

[0075] TABLE VI: Hull/Performance Data

<u>Revised</u>		<u>Foil System</u>	
<u>(3) Lift and drag</u>		45k	
<u>Hulls</u>	$a = \text{Trim } 3 \text{ deg} \times \exp 1.1 = 3.35$. $Y = \text{Length}/\text{beam} = 3/2.9 = 1.03$. $V = 76.01 \text{ f/s}$. $g = 32.2$ $cv = V / ((gB) \exp .5) = 7.86$. $Cdl = [a \exp 1.1 (.012y \exp .5 + .0095y \exp 2 / cv \exp 2)] =$ $3.35 (.0121 + .010/61.77) = 3.35 (.0121 + .0006) = .042$. 0 deg foil rise $Cdl = .9 \times .042 = .038$ $\text{Lift} = Cdl \times \text{pitot pressure} \times B \times B \times 2 = .038 \times 5742 \times 2.9 \times 2.9 \times 2 = 3670$		
<u>(9) Wetted surface</u>		A 45 k	
<u>Hulls</u>	<u>Horizontal</u>	<u>Water</u>	<u>(c) Frictional resistance. Cf x press x area</u>
	Width ave	2.9	<u>Hulls</u>
	Length	3	Water Hor $1.182 \times 10 \exp -3 \times 17.4 \times 5742$ 117
	Number	2	Vert $1.182 \times 10 \exp -3 \times 7.2 \times 5742$ 48
	Area	17.4	
	<u>Vertical</u>	<u>Water</u>	
	Height ave	0.6	
	Length	3	
	Number	4	
	Area	7.2	
<u>(3) Lift and drag</u>			
<u>Bow Foils</u>	Lift=		=2584
	Drag=L/(L/D)	2584/10=258	
<u>(d) Residual resistance -Tan Trimx Lift -Horizontal only</u>			
<u>Hulls</u>	Residual	$3670 \tan 5 \text{ deg}$	321
	Frict horizontal		117
	vertical		48
			486

[0076] A method for calculating the enhanced performance of the preferred embodiments is indicative of the highly desirable features of the present invention. The method for calculating the amount of enhancement of performance from modifying the boat with cambered bow, forward and/or center tunnel and stern foils, includes the steps of:

[0077] Defining before modification the boat height above waterline, wetted surface, trim angle, drag, weight, horse power and revolutions per minute vs speed. TABLE III shows cambered foils for calculating the enhanced performance from sea trials of a catamaran 26.5 feet in length with weight of 10000 pounds and 400 rated hp requires 5500 rpm to reach 41 mph;

[0078] Defining modifications: the dimensions of the bow, forward tunnel, center tunnel and stern cambered foils; length, beam, aspect ratio, camber coefficient, trim angle of water flow, degrees of floor rise and weight. Specific dimensions are shown in the accompanying TABLES, particularly the specifications of the bow, stern, center and forward cambered foils;

[0079] Defining foil lift: based on lift coefficient, pressure and foil beam. Lift coefficient is estimated from aspect ratio, camber coefficient and trim angle of water flow and was obtained from a US Navy report "Graphs For Designing Cambered Planing Surfaces." Pressure is based on cambered foil speed vs height above water obtained from regression calculations from sea trial data of prototype cambered foils, showing (1) Clb and Lift/drag; (3) Lift and drag; (5) Stern foil trim, height, pressure and camber; (6) Center foil trim, height, pressure and camber; (7) Forward foil trim, height, pressure and camber. (8) Bow foil trim, height, pressure and camber; (9) Wetted surface; (10) Vertical drag; (12) Appendage resistance; (13) Wind resistance;

(3) Lift and drag; and (9) Wetted surface. Revisions are required to have lift equal to craft weight of 10000 Ibs;

[0080] Defining foil drag: based on foil lift/(lift/drag ratio) . Lift /drag ratio was obtained from US Navy report 3147 and was based on aspect ratio, lift coefficient and trim angle of water. Vertical drag was estimated from vertical wetted surface times coefficient of friction. Drag, (9) wetted surface and revised drag of 1711 Ibs;

[0081] Defining after modification hull lift: based on lift coefficient, pressure and beam (3) shows hull lift and (2) shows pressure;

[0082] Defining after modification hull drag including: based an frictional resistance, reduced hull wetted surface, coefficient of friction, residual hull resistance, wind and appendage resistance. The data shows revised hull drag and wetted surface; (10) frictional resistance, (12) appendage resistance and (13) wind resistance;

[0083] Defining speed vs. horsepower before and after modification with cambered foils: based on speed equal to propulsive horsepower x 550 divided by foil and hull drag where propulsive hp equals 0.6 times rated horsepower times required divided by rated rpm. Performance shows 400 rated hp requires 5408 rpm to achieve 51.8 mph; and

[0084] Defining the amount of enhanced performance: based on the above method of calculation indicates a 26.6 ft catamaran with 400 horsepower had a speed of 41 mph before modification compared to 51.8 mph after modification with cambered foils, an increase of 26%.

[0085] Enhanced performance of the preferred embodiments during sea trials of a 23 ft prototype with 275 hp at 82% of rated rpm in smooth water showed the bow and stern foils generated lift of 58% of craft weight of 4048 Ibs (including passengers and fuel, raised hull, reduced wetted surface and increased hull speed of 9.2% to 45

knots). In rough water to reduce pitching and the risk of flipping at high speeds going into rough waves the bow height and lowering the stern foils reduced trim. This increases the stern foil lift and reduces the angle of attack on the bow foils that reduces the bow lift and generates bow down stern lift.

[0086] Increasing the angle of attack (α) of the propeller shaft also reduces the angle of attack on the bow foils and which reduces bow lift and height. The bow height and trim was increased by lowering the propeller shaft angle to raise the stern foils to prevent the bow from diving in a following, rough sea. Trials were conducted in waves height of 3.7 ft and winds of 55 knots. The 23 foot prototype at 3000 of rated 5500 rpm speed without foils in a head sea was 10 k or less. The addition of the bow and stern foils increased the speed to 22 knots reduced the pitch to 63% or 17 degrees and vertical acceleration g loading to 58% or 5g. The foil system increased the moment of inertia by over 5 times. Increased moment of inertia reduces pitching, vertical accelerations and wave shock and improved top speed, stability and comfort in rough water.

[0087] The method for calculating the amount of enhancement of performance from modifying different boats with cambered bow, tunnel and stern foils indicated increased speed, lift/drag ratios and efficiency with reduced propulsive power. This method for calculating performance indicated a US Navy 23 foot test craft required 134.4 propulsive hp without foils at 40.7 knots and 135.5 propulsive hp with foils at 44.5 knots compared to actual propulsive hp of 135 in actual sea trials.

[0088] Dense spray generated by the cambered bow foils flowing thru the rigid airtight adjustable cambered stern foils dampens pitch and vertical accelerations in a rough sea. The method for calculating enhanced performance was based on sea trials in smooth and rough water. Trial data was obtained on: density of tunnel spray,

speed, pitch, roll and vertical acceleration vs. engine rpm, power, weight and wave height from a 23 ft prototype with 275 horsepower with and without cambered foils. Calculating methods were developed based on this and other data to estimate lift and resistance from the hulls, bow, tunnel and stern cambered foils at different engine rpm and power. This method of calculation accurately predicted lift, resistance and speed vs power for the prototype with and without foils installed.

[0089] The lift/resistance ratio was 29% higher with the foils installed than without the foils installed. The U.S. Navy tested the prototype and recommended “the foil system as tested appears to improve craft performance in a seaway.” “The foil system prevents the bow from diving in following seas or pitching in a head sea; reduces the g-loading in a Beam sea; and finally, increases the craft speed at the top end. We recommended that the foil system concept be considered for application and evaluation of future U.S. Navy hulls.”

[0090] The invention being thus described, it will be obvious that the same may be varied in many ways. Such variations are not to be regarded as a departure from the spirit and scope of the invention, and all such modifications as would be obvious to one skilled in the art are intended to be included within the scope of the following claims.

WHAT IS CLAIMED IS:

1. A boat hull comprising:

a bow and a stern;

a waterline extending between said bow and said stern;

at least one tunnel extending axially in a direction from said bow toward said stern and having a forward end, a center region and an aft end;

a pair of flexible cambered foils, said flexible cambered foils supported on sides of said bow beneath the water line, said flexible cambered foils being capable of controlling a flow within said at least one tunnel and creating a dense spray in an end of said tunnel while cushioning shock and lifting said bow; and

at least one fixed, cambered foil at the aft or the forward end of said at least one tunnel generating lift from a pressure being generated by the dense spray within said at least one tunnel.

2. The boat hull according to claim 1, further comprising at least one cambered foil at the aft end and at least one cambered foil at the forward end of said at least one tunnel generating lift from a pressure being generated by the dense spray within said at least one tunnel.

3. The boat hull according to claim 1, said boat hull further comprising a v-bottom or rigid inflatable hull.

4. The boat hull according to claim 1, said boat hull further comprising a catamaran hull.

5. The boat hull according to claim 1, further comprising a rigid cambered stern foil forming a skirt extending substantially across the tunnel and peripherally enclosing a transom of said stern, said stern foil being capable of preventing air from escaping, compressing said dense spray and thereby lifting said stern.

6. The boat hull according to claim 5, further comprising a center tunnel cambered foil at said forward end being fixed or variable in height, said stern cambered stern foil being variable in height and or in trim so as to control the lift of said hull.

7. A boat hull comprising:

a bow and a stern, said stern including a transom;

a waterline extending between said bow and said stern;

a pair of tunnels extending axially in a direction from said bow toward said stern and having a forward end, a center region and an aft end;

a pair of flexible cambered foils, said flexible cambered foils supported on sides of said bow beneath the water line, said flexible cambered foils being capable of controlling a flow within said at least one tunnel and creating a dense spray in an end of said tunnel while cushioning shock and lifting said bow; and

at least one pair of cambered tunnel foils at the aft or forward ends of said tunnels, respectively, wherein each of said tunnels includes a respective tunnel foil

generating lift from a pressure being generated by the dense spray within said at least one tunnel.

8. The boat hull according to claim 7, wherein said tunnel foils are positioned at said forward ends of said tunnels.

9. The boat hull according to claim 7, wherein said tunnel foils are positioned at said center section of said tunnels.

10. The boat hull according to claim 7, further comprising a pair of cambered stern foils forming a skirt extending substantially across said tunnels so as to peripherally enclose said transom and prevent air from escaping, compressing said dense spray and lifting thereby said stern.

11. The boat hull according to claim 8, further comprising a pair of cambered stern foils forming a skirt extending substantially across said tunnels so as to peripherally enclose said transom and prevent air from escaping, compressing said dense spray and lifting thereby said stern.

12. The boat hull according to claim 9, further comprising a pair of cambered stern foils forming a skirt extending substantially across said tunnels so as to peripherally enclose said transom and prevent air from escaping, compressing said dense spray and lifting thereby said stern.

13. The boat hull according to claim 7, said boat hull further comprising a v-bottom or rigid inflatable hull.

14. The boat hull according to claim 7, said boat hull further comprising a catamaran hull.

15. The boat hull according to claim 1, wherein at least one of said foils includes a foil assembly, said foil assembly including

a main cantilevered, flexible cambered metal foil,

a rubber shock pad,

reinforcing material,

a bolt plate, and

a bolt and lock nut assembly.

16. A method of modifying the powered boat hull claimed in claim 1 to obtain enhanced lift, performance and rough water stability with said cambered foils, said method comprising the steps of :

(a) defining a boat height above a waterline, a wetted surface area, a trim angle, a hull weight and a horse power vs. speed requirement;

(b) defining dimensions of the cambered foils and hull, said dimensions including length, beam, camber, trim, floor rise and weight;

(c) defining foil lift and drag based on said cambered foil dimensions, trim, spray density, speed, height above waterline, wetted surface area, coefficient of friction and sea trial data from prototype cambered foils;

(d) modifying a hull with a hull modification to incorporate said cambered foils;

(e) defining hull lift and drag aft the hull modification based on water pressure, beam, length, trim, velocity, gravity, coefficient of friction, floor rise, wetted surface, residual hull resistance, appendage and wind resistance;

(f) defining the speed vs. horsepower before and aft said hull modification with cambered foils; and

(g) calculating enhanced performance.

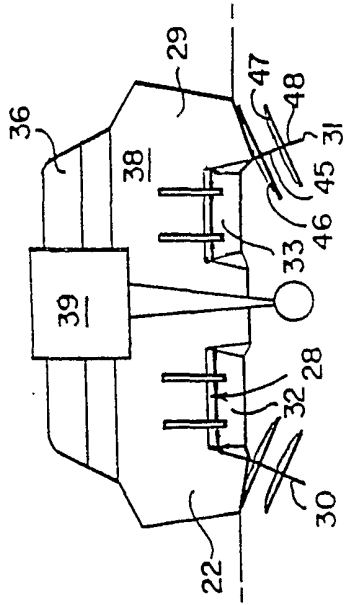

FIG. 2

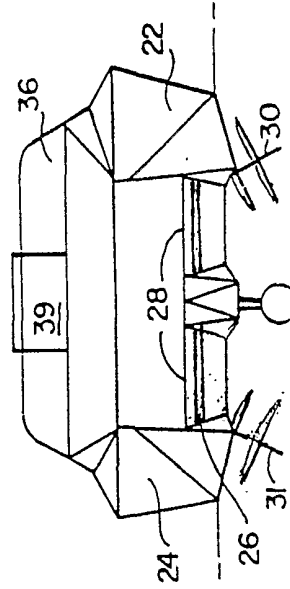

FIG. 3

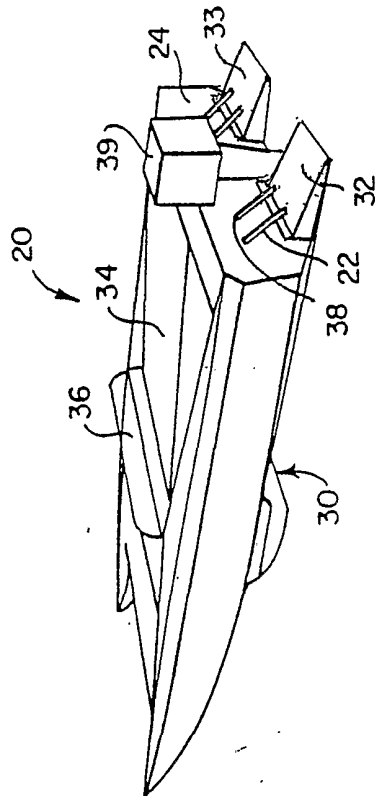

FIG. 1

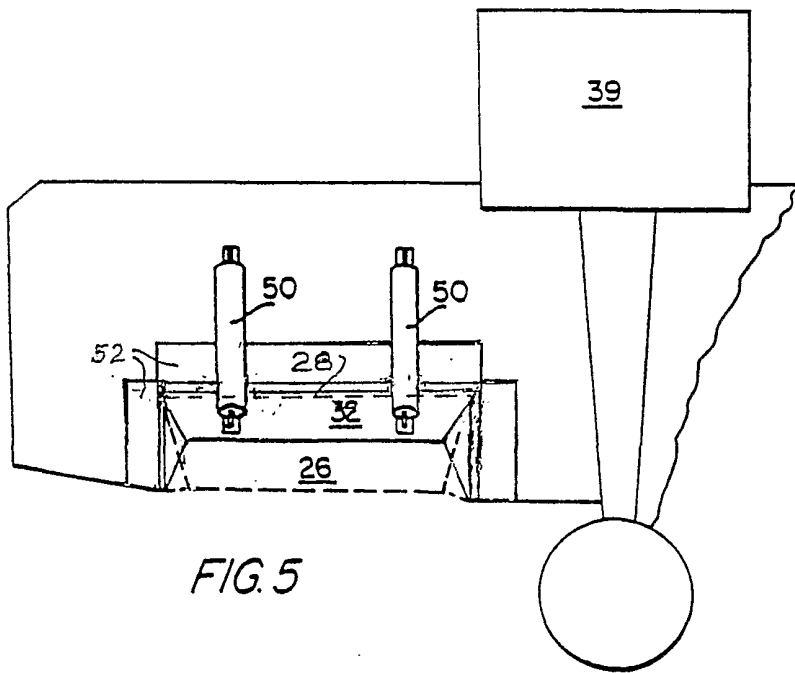
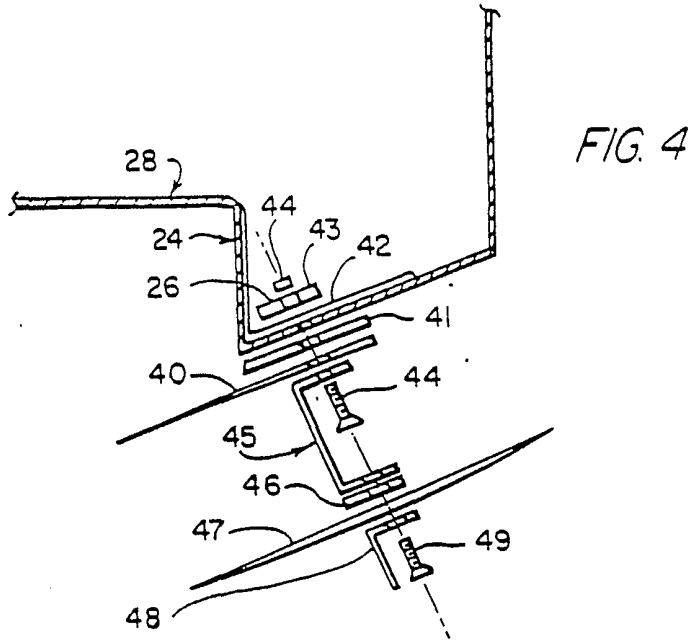

FIG. 6

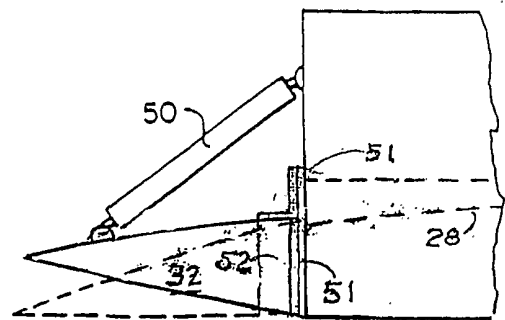

FIG 7

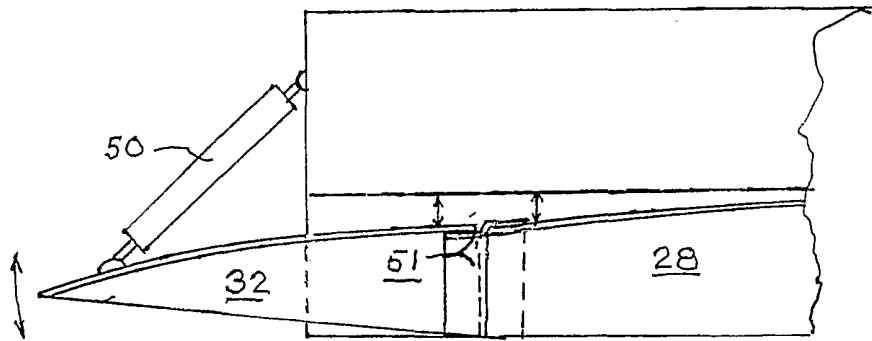
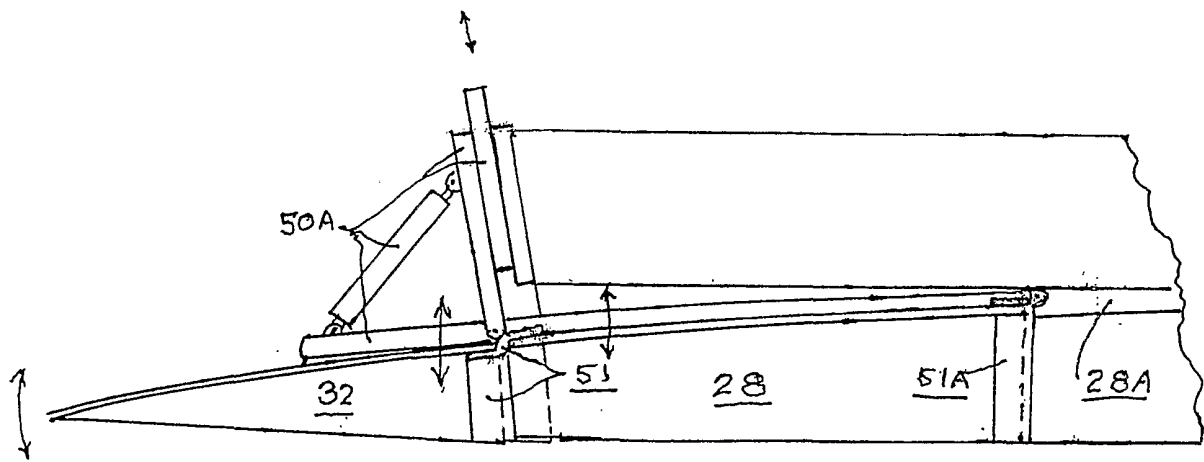

FIG 8



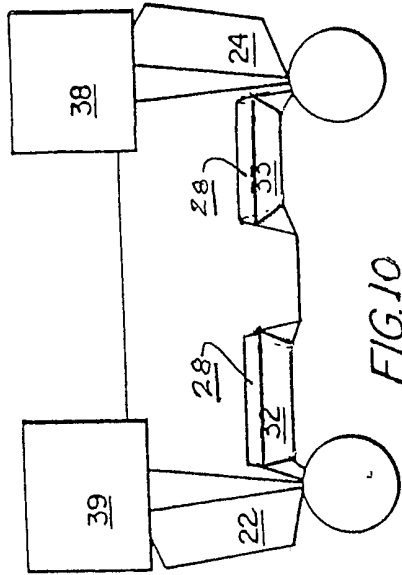

FIG. 10

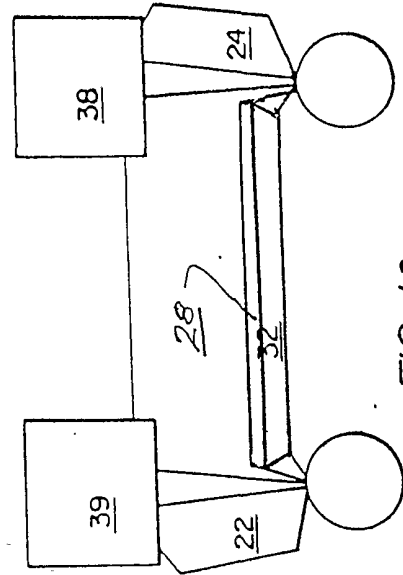

FIG. 12

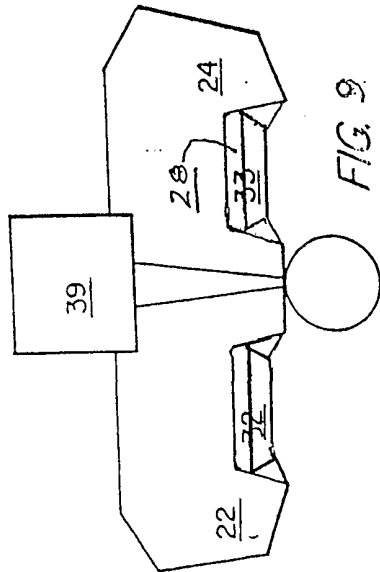

FIG. 9

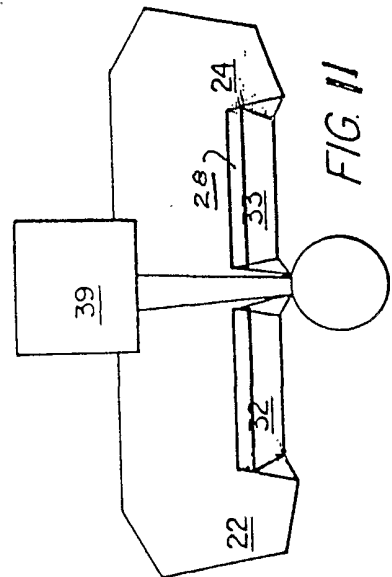

FIG. 11

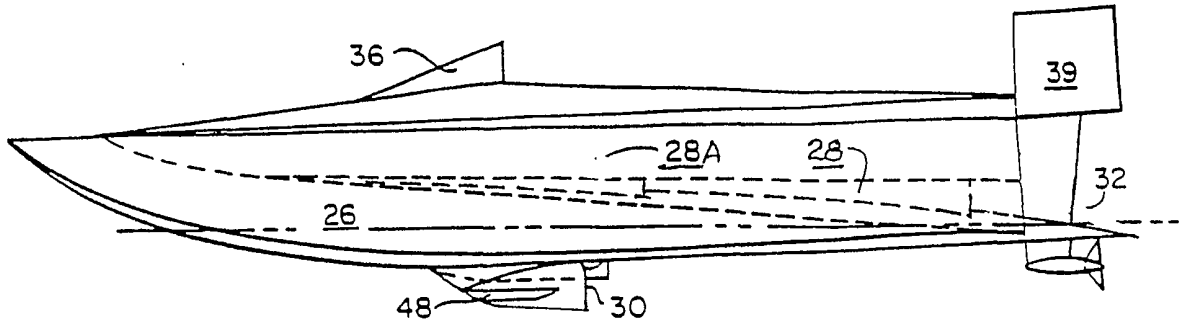

FIG. 13

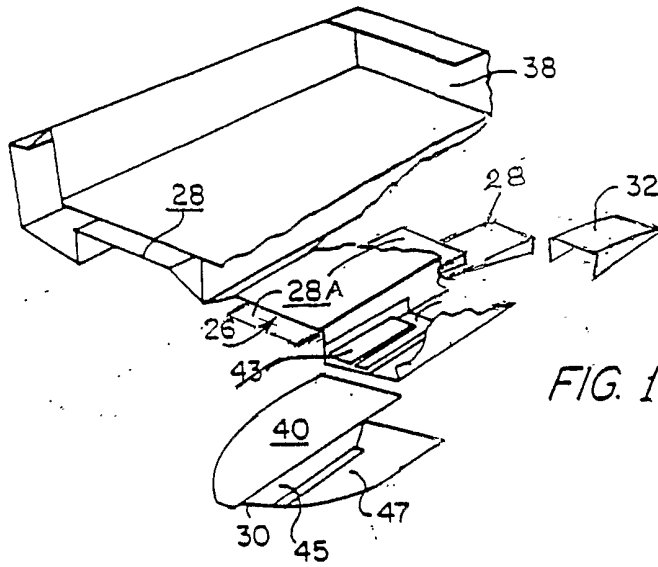

FIG. 14

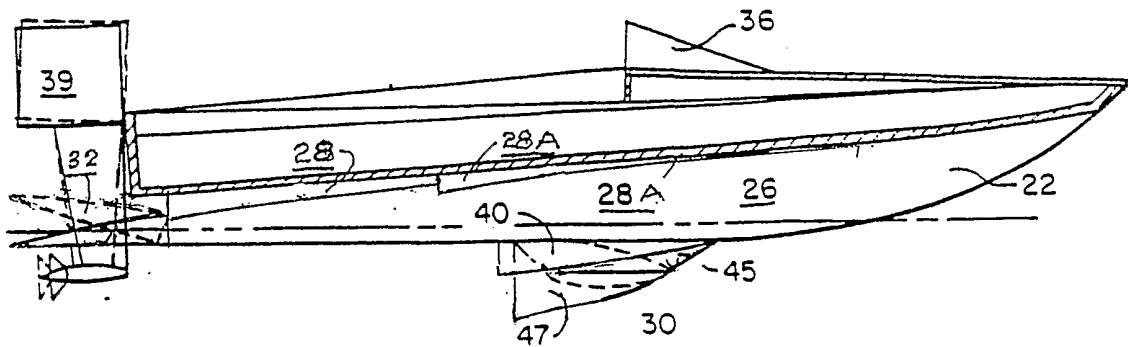
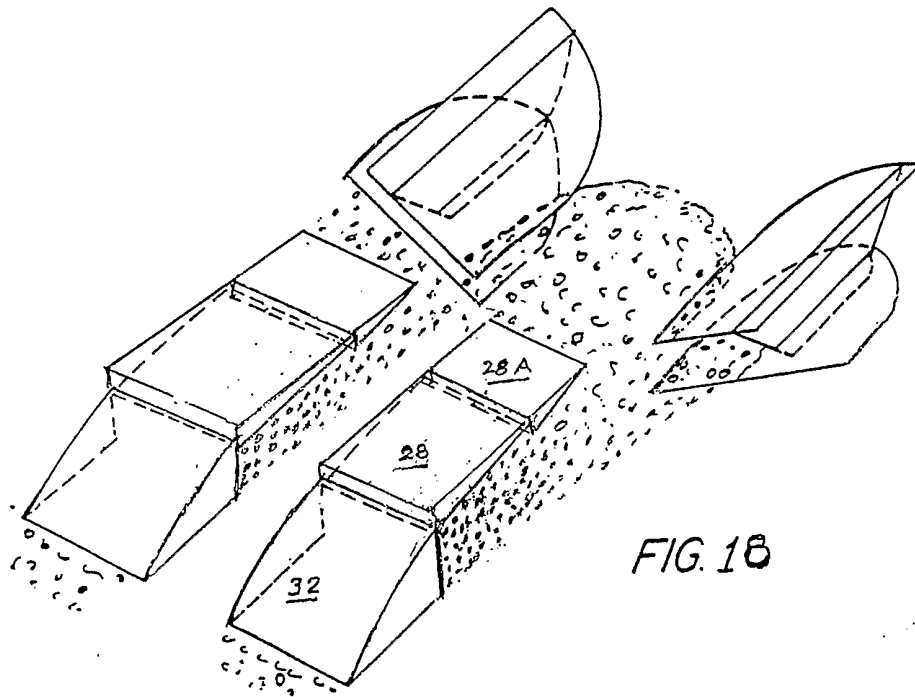
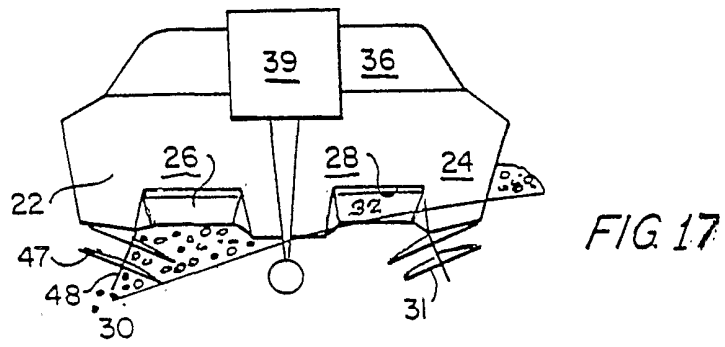
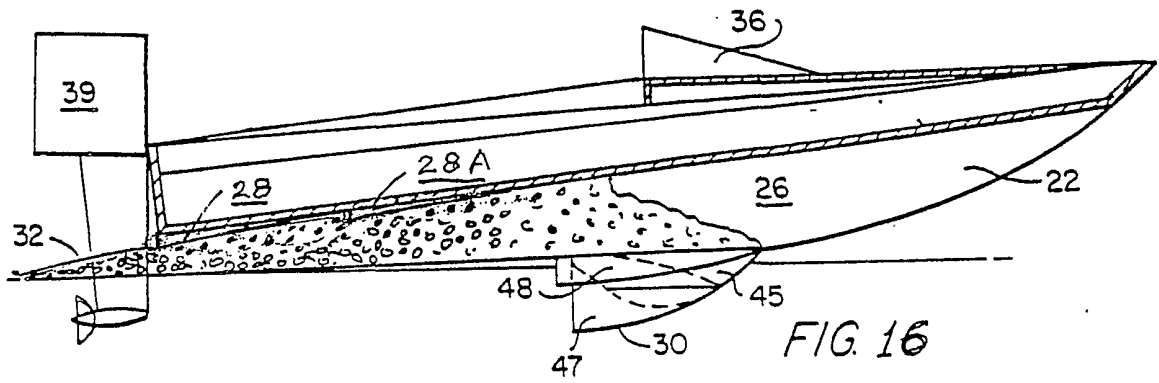
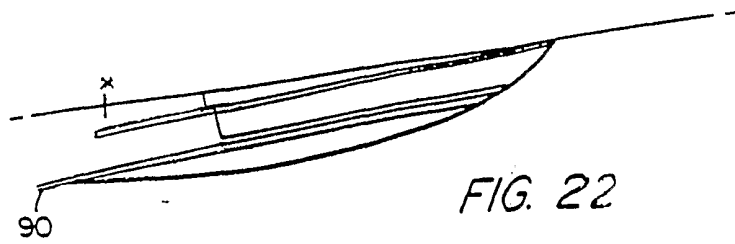
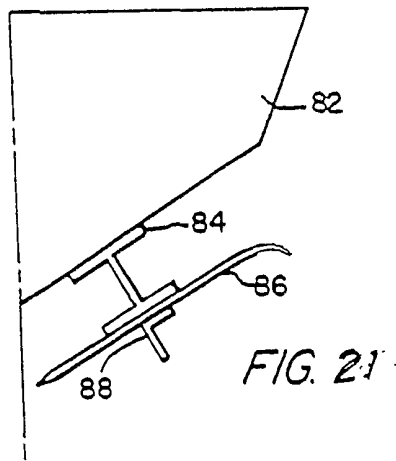
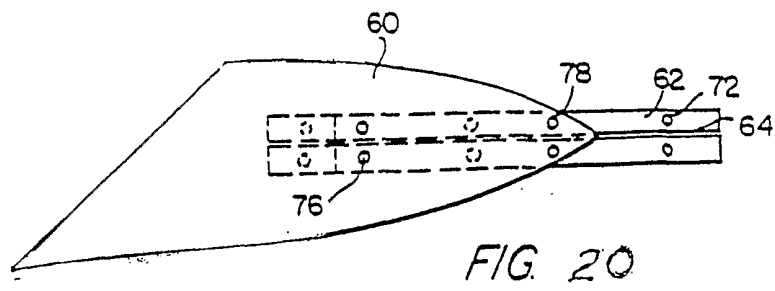
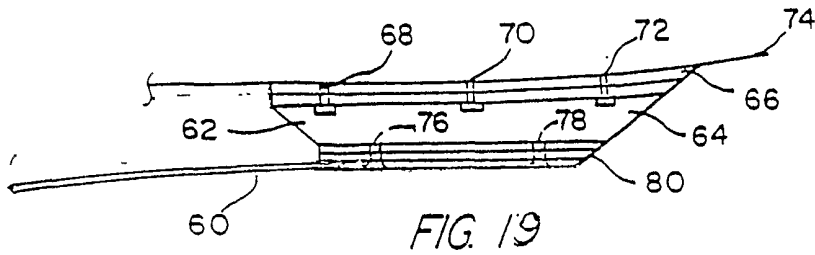

FIG. 15





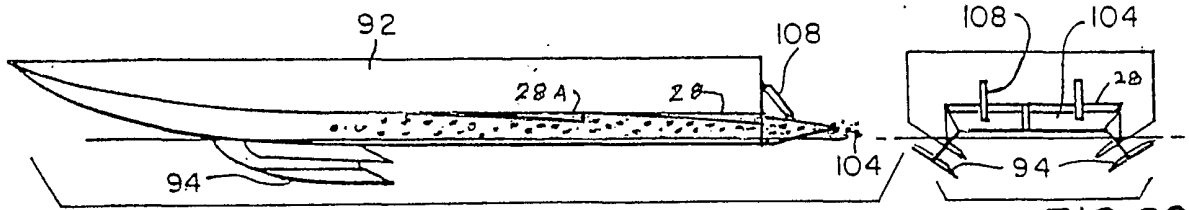

FIG. 23

FIG. 29

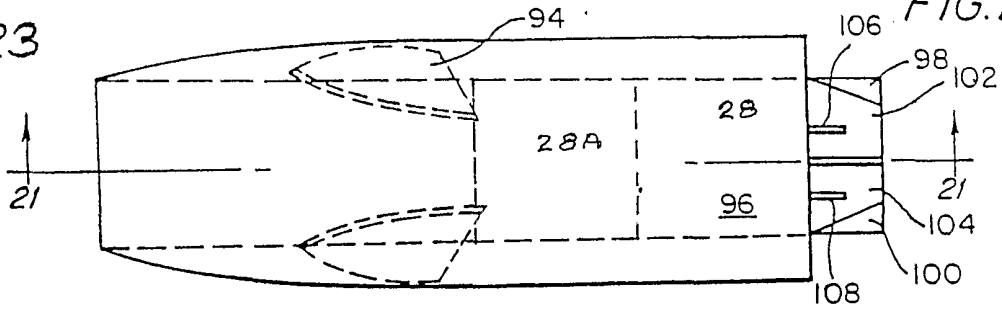

FIG. 24

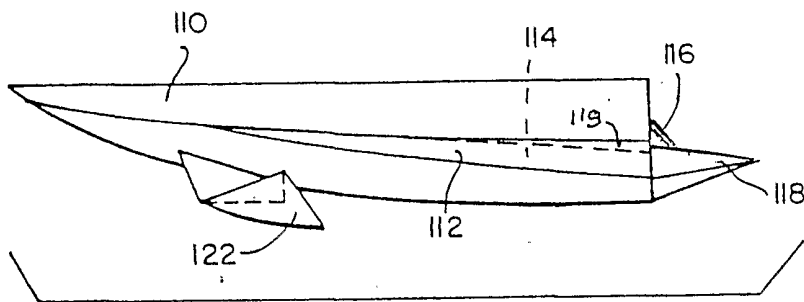

FIG. 25

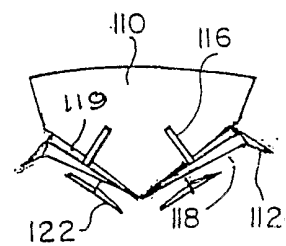

FIG. 26

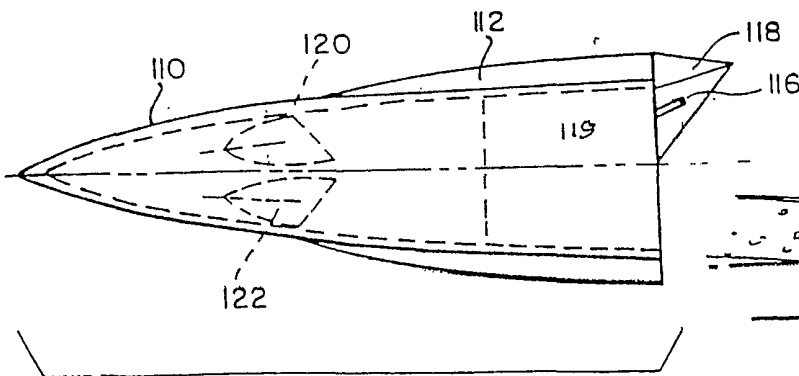

FIG. 27

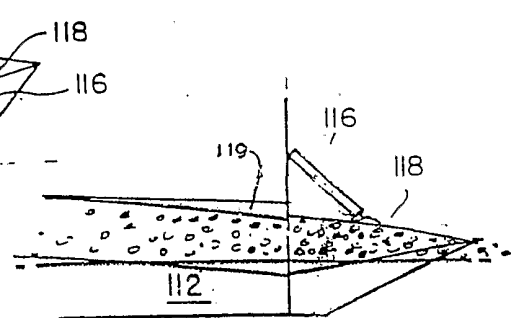

FIG. 28

METHOD FOR CALCULATING ENHANCED PERFORMANCE
CAMBERED FOILS FOR CATAMARAN 26.5 FT.
SHEET C

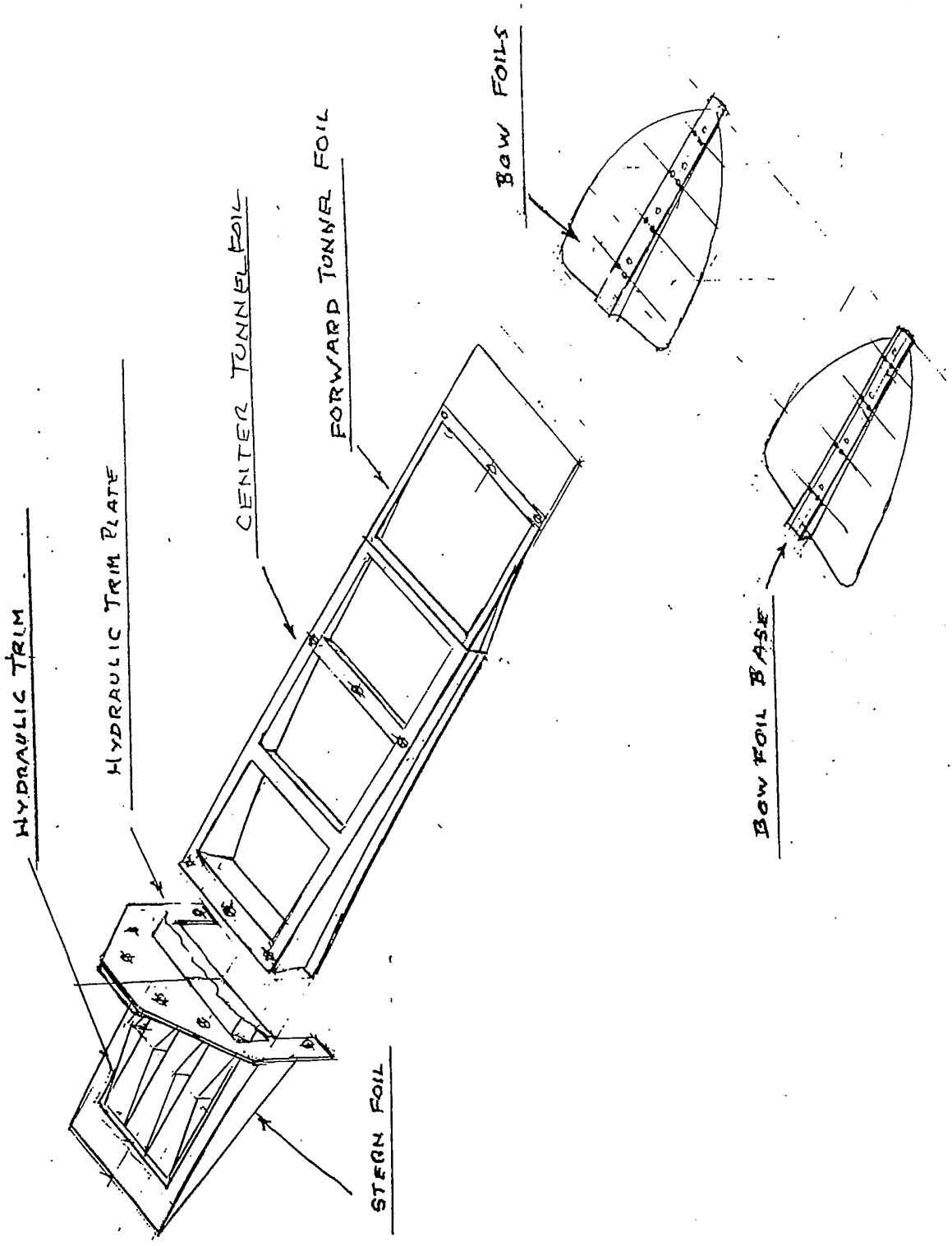

FIG. 30