



INTERNATIONAL APPLICATION PUBLISHED UNDER THE PATENT COOPERATION TREATY (PCT)

(51) International Patent Classification 5 : B27K 3/00	A1	(11) International Publication Number: WO 90/11171 (43) International Publication Date: 4 October 1990 (04.10.90)
(21) International Application Number: PCT/US90/01591 (22) International Filing Date: 20 March 1990 (20.03.90) (30) Priority data: 326,196 20 March 1989 (20.03.89) US (71) Applicant: WEYERHAEUSER COMPANY [US/US]; Tacoma, WA 98477 (US). (72) Inventors: NEOGI, Amar, N. ; 12531 17th Avenue N.E., Seattle, WA 98125 (US). YOUNG, Richard, H., Sr. ; P.O. Box 1153, Puyallup, WA 98371 (US). (74) Agents: PETERSEN, David, P. et al.; Klarquist, Sparkman, Campbell, Leigh & Whinston, 121 S.W. Salmon Street, 1600 One World Trade Center, Portland, OR 97204 (US).		(81) Designated States: AT (European patent), AU, BE (European patent), CH (European patent), DE (European patent), DK (European patent), ES (European patent), FI, FR (European patent), GB (European patent), IT (European patent), JP, KR, LU (European patent), NL (European patent), NO, SE (European patent). Published <i>With international search report.</i>
(54) Title: A NATURAL FIBER PRODUCT COATED WITH A THERMOPLASTIC BINDER MATERIAL (57) Abstract <p>Discontinuous natural fibers have a coating of a thermoplastic binder. A substantial majority of the fibers and any fiber bundles are unbonded to one another by the thermoplastic binder material. One or more solid particulate materials may be adhered to the fibers by the binder material. The binder material is heat fusible and the coated fibers can be mixed with other fibers for subsequent heat bonding and used in producing a wide variety of products.</p>		

DESIGNATIONS OF "DE"

Until further notice, any designation of "DE" in any international application whose international filing date is prior to October 3, 1990, shall have effect in the territory of the Federal Republic of Germany with the exception of the territory of the former German Democratic Republic.

FOR THE PURPOSES OF INFORMATION ONLY

Codes used to identify States party to the PCT on the front pages of pamphlets publishing international applications under the PCT.

AT	Austria	ES	Spain	MG	Madagascar
AU	Australia	FI	Finland	ML	Mali
BB	Barbados	FR	France	MR	Mauritania
BE	Belgium	GA	Gabon	MW	Malawi
BF	Burkina Faso	GB	United Kingdom	NL	Netherlands
BG	Bulgaria	HU	Hungary	NO	Norway
BJ	Benin	IT	Italy	RO	Romania
BR	Brazil	JP	Japan	SD	Sudan
CA	Canada	KP	Democratic People's Republic of Korea	SE	Sweden
CF	Central African Republic	KR	Republic of Korea	SN	Senegal
CG	Congo	LI	Liechtenstein	SU	Soviet Union
CH	Switzerland	LK	Sri Lanka	TD	Chad
CM	Cameroon	LU	Luxembourg	TG	Togo
DE	Germany, Federal Republic of	MC	Monaco	US	United States of America
DK	Denmark				

- 1 -

A NATURAL FIBER PRODUCT COATED WITH A
THERMOPLASTIC BINDER MATERIAL

Background of the Invention

The present invention relates to discontinuous
5 natural fibers coated with thermoplastic binder materials
and also to adhering solid particulate materials to the
binder. The particulate material is adhered to the fibers
by the thermoplastic binder material as the binder
material dries.

10 A number of techniques for applying binders to
webs of fibers are known. For example, U.S. Patent No.
4,600,462 of Watt describes a process in which an adhesive
binder is sprayed onto one or both surfaces of an air laid
cellulose fiber web. Submersion of the web in the
15 adhesive binder is another method disclosed in this patent
of applying the binder. Individual binder coated fibers
for mixing with other fibers are not produced by this
process. A hydrophile solution is also applied to the
web. As another example, U.S. Patent Nos. 4,425,126 and
20 4,129,132 of Butterworth, et al. describe a fibrous
material formed by combining thermoplastic fibers and wood
pulp, heat fusing the combined fibers, and thereafter
depositing a binder on the heat fused web. Because the
fibers are heat fused prior to adding the binder,
25 individual binder coated fibers for mixing with other
fibers are not produced by this process.

U.S. Patent No. 4,584,357 of Harding discloses a
latex treated cationic cellulose product and method for
its manufacture. In the Harding approach, cationized
30 cellulose is treated in an aqueous suspension with an
anionic polymer emulsion of from 0.1 to 30 percent on a
dry weight basis. The patent mentions that the resulting
resin treated products can be prepared in sheet form, as
loose fibers or in another form. The approach of the
35 Harding patent is limited to cationic fibers. Also, the
fiber coating applied as described in the Harding patent
had a tendency to flake off or separate from the fibers.
Moreover, because the Harding approach uses a wet process,

- 2 -

the lumen of the cellulose fibers is penetrated by the polymer emulsion. Since the binder on the surface of the fibers contributes principally to the desired characteristics of the fiber, any polymer that penetrates the lumen of the fiber adds little to these desired characteristics.

U.S. Patent No. 4,469,746 of Weisman et al. discloses fibrous webs comprised of fibers coated with a continuous film of silica. The fibers are understood to be dispersed in a charged silica aquasol to accomplish the coating. Because silica is an inorganic material, the silica does not contribute to subsequent bonding of fibers. In addition, because Weisman et al. discloses a wet process, the silica will tend to penetrate the lumen of cellulose fibers in the event such fibers are being treated in accordance with this patent.

U.S. Patent Application Serial No. 067,669, filed June 26th, 1987, and entitled "Treated Wood Fiber Having Hydrophobic and Oleophilic Properties", by Jewell et al., mentions an approach of treating fiberized wood with surfactant material to penetrate the surface of the wood fibers. In this approach, fiberized wood at the outlet of a first fiberizing machine passes through an orifice into a blow line. At the outlet of the fiberizing machine, liquid surfactant is injected into the line. At the point of addition of the surfactant, the fiber is still wet as it has been carried by steam through the fiberizing machine. Surfactants are not suitable for use in subsequent bonding of the fibers. The Jewell et al. patent application also describes a process in which fibers are treated with a copolymer latex, such as a combination of a paraffin wax emulsion and a styrene butadiene copolymer latex. The patent describes a suitable treating process as involving the blending of the aqueous latex emulsion with wood fiber in a typical mechanical wood fiber blender. This approach tends to produce fibers which are bound together by the latex.

U.S. Patent No. 2,757,150 of Heritage mentions a fiber treatment approach in which fibers are carried by steam under pressure and in which a thermoset resin, in contrast to a thermoplastic binder material in accordance with the present invention, is introduced into the fiber stream. Other materials (i.e., rosin and wax) are mentioned as being simultaneously introduced into the fiber stream. The patent indicates that such materials penetrate the surface of the fibers. This patent mentions the individualization of these treated fibers. A relatively low concentration of the thermoset resin (i.e. two percent by weight phenol formaldehyde) is specifically described in this patent. At such low concentrations, the resin is in discontinuous random non-interconnected areas (blobs or globules) on the fibers. These treated fibers are typically used in hardboard. In current hardboard resin products produced using the approach of the Heritage patent and known to the inventors, a phenolic resin concentration of from a maximum of five to six percent by weight is used. Even at these concentrations, the resin forms random non-interconnected globules on the fibers. As a result, the uncoated resin free areas of the fibers lack the capacity to bond in comparison to the areas of the fibers covered by the resin. In addition, the untreated surface areas of the fibers may lack desired characteristics of the resin covered areas of the fibers. For example, these uncoated areas may cause the fibers to be more water absorbent than if the entire fiber were coated.

U.S. Patent No. 4,006,887 of Engels describes a process for treating wood fibers in which the fibers are supported as an annular loose fluidized bed in a mixer which delivers glue by way of shaft mounted mixing rods to the fibers. The patent mentions that radial air vortices are established with the mixer inlet and outlet funnels being connected to an air transport pipe. The patent describes the resulting product as homogenous lump free uniformly coated wood fibers. The patent mentions that

the coating of fibers is useful in the manufacture of wood fiber panels. The glue used in the Engels patent and the percentage of the glue that is used is not discussed.

The background portion of the Engels patent
5 describes German Auslegeschrift 1,048,013 as disclosing an impeller or agitator mixer for the coating of wood chips with dusty components. Glue is described as being sprayed through nozzles into a mixing container. An air stream is described as being blown axially through the mixing
10 container in order to reduce the residence time of dusty chip particles to reduce excessive coating of such dusty particles. Also, German Offenlegung 1,632,450 is mentioned by Engels as disclosing wood chips agitated in an air stream in a mixing tube in which glue spray nozzles
15 are mounted.

Heretofore, synthetic bicomponent fibers have been formed by extruding two materials in air in side-by-side strands which are connected together along their length. Such bicomponent fibers have also been
20 formed with one material being extruded as a concentric sheath surrounding the other material. These extruded strands are then chopped or broken into discontinuous fibers. Although synthetic bicomponent fibers provide good structural efficiency, they are very expensive in
25 comparison to natural fibers, and, therefore, their use is limited.

U.S. Patent No. 4,261,943 of McCorsley, III describes the extrusion of filaments and the application of a solution of a nonsolvent liquid to the filaments. In
30 this application process, the filaments are passed through a chamber having a nonsolvent vapor laden atmosphere, i.e. a fog of minute particles of nonsolvent. Spraying of the nonsolvent liquid onto the filaments is also mentioned. The approach of the McCorsley, III patent is not
35 understood to apply to discontinuous fibers.

U.S. Patent No. 4,010,308 of Wiczer describes foamed porous coated fibers. Fibers, described as organic or inorganic fibers of any character, are described as

- 5 -

being coated with a foamable plastic material. Thermoplastic and thermosetting coatings are mentioned. In several examples, the coated fibers are made by passing continuous extruded filaments through a first bath of a ten percent polystyrene solution in toluene, evaporating the solvent, and passing the polystyrene coated fiber through a second bath containing a blowing agent, such as liquid n-pentane. The treated filaments are then heated to foam the coating. Rolls are used to rub solid particles into the porous surface of the foam coating. Fireproofing agents, lubricants such as graphite, pigments, and insecticides are among the examples of solid materials mentioned as suitable for rubbing into the coating. In another example, short lengths of cotton linters are described as being wet with a ten percent solution of a copolymer of polystyrene and acrylonitrile in about equal proportions dissolved in benzene. The solvent is evaporated in an air stream and the resulting coated cotton fiber is dipped in mixed pentanes. The product is then stirred in boiling water to cause foaming. Following foaming, the product is centrifugally dried and again dried in an air stream. The fiber is then mixed with a dry powder to fill the pores in the foamed coating with the powder. The placement of this fiber product in a container and heating the product to cause the adherence of the fiber surface contact points is also mentioned. The Wiczer patent appears to use a solution dipping approach as a means of applying the coating to the fibers.

U.S. Patent No. 4,160,059 of Samejima describes a process in which a natural cellulose fiber (such as wood pulp fiber) is shredded and blended in air with a heat-fusible fiber. The blend is fed to a disintegrator to form supporting fibers to which an absorptive material is added. Heated air is applied to the resulting web to heat the web to a temperature above the melting point of the heat fusible fiber to form bonds between the supporting fibers and absorptive material by heat fusion. Activated carbon black, Japanese acid clay, active

alumina, and diatomaceous earth are mentioned as representative absorptive materials. Other powders, including superabsorbents, are also mentioned as being bonded in place in this manner. The background portion of this particular patent also mentions a process in which wood pulp is disintegrated by a dry process, blended with active carbon black, and the blend spread on a wire screen. A binding material such as latex, starch and the like can also be sprayed on both surfaces of the web.

10 With this latter approach, the active surface of the absorptive material is covered with a thin film of the binding material. Thus, under the Samejima approach, heat fusion is used to bind the particles to the fibers. As a result, a bound fiber web, as opposed to individualized

15 fibers, is formed with the particles heat fused to the fibers.

In U.S. Patent No. 4,429,001 of Kolpin et al., melt-blown fibers are prepared by extruding liquid fiber-forming materials into a high-velocity gaseous stream. The stream of fibers is collected on a screen disposed in the stream with the fibers being collected as an entangled coherent mass. Absorbent particles are introduced into the stream of fibers at the point where the fibers are solidified sufficiently that the fibers

20 will form only a point contact with the particles. The patent mentions that the particles can also be mixed with the fibers under conditions that will produce an area of contact with the particles. The introduction of other fibers besides melt-blown fibers into the resulting sheet

25 product is also mentioned. The patent mentions that surfactants in powder form can be mixed with the sorbent particles used in forming the web or surfactants in liquid form can be sprayed onto the web after it is formed.

Finally, U.S. Patent No. 4,392,908 of Dehnel

35 describes a process for forming a thermoplastic adhesive resin on a surface of water soluble particles. The coated particles in a dry state are heated and pressed to bond them to a dry substrate (i.e. cellulose fluff). Mixing of

- 7 -

absorbent particles with an aqueous latex, spraying resin onto the particles, and mixing the particles in a slurry are mentioned as approaches for coating the particles. Milling of the particles after coating with thermoplastic
5 is mentioned as usually being necessary to produce free flowing particles. Thus, the Dehnel patent illustrates another approach for heat fusing particles to fibers.

Although prior art approaches are known, a need exists for an improved method of treating discontinuous
10 fibers with a binder material and for adhering particles to fibers treated in this manner.

Summary of the Invention

In accordance with the present invention, discontinuous natural fibers have a thermoplastic binder
15 coating thereon in an amount which is sufficient to produce bicomponent fibers having a substantially continuous layer of the binder material on their surface. A substantial majority of the resulting bicomponent fibers are unbonded. By using a heat bondable organic polymeric
20 thermoplastic material as the binder, the fibers may be subsequently heated to fuse them together. The fibers may also be combined with other nontreated fibers and heat fused to provide a bonded web.

In accordance with the present invention, the
25 fibers may have substantial amounts of thermoplastic binder material yet still comprise individualized coated fibers. It has been found that the thermoplastic binder material must be included in an amount of at least about seven percent of the combined dry weight of the binder
30 material and fibers in order to produce a substantially continuous binder coating on the fibers. With a substantially continuous coating, little or no surface area of the fibers is exposed and the desired characteristics added to the fibers by the binder material
35 are not nullified or significantly altered by uncoated areas of the fiber. With a thermoplastic binder level of at least about 10 percent of the combined dry weight of the binder material and fibers, the coated fibers are

- 8 -

capable of bonding relatively strongly to one another when heat fused. In addition, fibers with thermoplastic binder levels of 30 percent to 50 percent and higher, such as above 90 percent and with no maximum limit yet being
5 determined, are included within the invention, while still resulting in a product comprised of substantially unbonded individualized fibers. At these higher levels of binder, the treated fibers may readily be mixed or blended with untreated fibers and used in heat fusing the blended
10 fibers. Also, higher binder levels are preferably used to adhere solid particulate materials to the fibers as explained below.

As another aspect of the present invention, the fiber product may include one or more solid particulate
15 materials adhered to the fibers by the thermoplastic binder material. Solid particulate material is applied to the fibers while the liquid binder material on the fibers is still at least partially wet. As the liquid binder material dries, the particulate material is adhered to the
20 fibers. Although not limited to specific materials, the particulate materials may comprise at least one material selected from the group comprising a pigment material, a super absorbent material, an abrasive material, an oleophilic material, an electrically conductive material
25 and a fire retardant material.

Although not as beneficial for many applications, such as when the properties of individual fibers are desired, in addition to individual fibers, the fiber product may comprise fiber bundles. A fiber bundle is an
30 interconnected group of two or more fibers that are not separated during processing. Fiber bundles, like individual fibers are much longer than wide. For example, when mechanically fiberized wood is produced, some individual fibers result along with fiber bundles of
35 fibers that are not separated during the mechanical fiberization process.

- 9 -

It is accordingly one object of the present invention to provide discontinuous natural fibers coated with a thermoplastic binder material.

It is another object of the present invention to provide such thermoplastic binder coated fibers which are substantially individualized or unbonded.

A further object of the present invention is to provide thermoplastic binder coated discontinuous natural fibers with the binder being present in an amount which is sufficient to substantially continuously coat the fibers, or in much higher amounts, with the fibers being substantially individualized or unbonded.

A still further object of the present invention is to provide thermoplastic binder coated fibers having one or more solid particulate materials, which impart functional benefits to the fibers, adhered to the fibers by the binder material.

Another object of the present invention is to provide substantially individualized discontinuous thermoplastic binder coated fibers, with or without particulate materials adhered thereto, for use in the manufacture of articles by heat fusing the fibers, with or without additional untreated fibers being added.

A further object of the invention is to form an air laid web directly with dried coated fibers and with partially wet coated fibers.

A subsidiary object of the present invention is to provide fiber bundles treated in the same manner as individual fibers are treated.

These and other objects, features and advantages of the present invention will be apparent with reference to the following detailed description and drawings.

Brief Description of the Drawings

Fig. 1 is a schematic illustration of one form of apparatus in which discontinuous fibers can be treated in accordance with the method of the present invention.

Fig. 2 is a side elevational section view of one form of binder application mechanism which can be used to

apply liquid binder material to discontinuous fibers in accordance with the method of the present invention.

Fig. 3 is a front elevational section view of the binder application mechanism of Fig. 2.

5 Fig. 4 is a schematic illustration of another form of binder application mechanism which can be used to produce the fiber product of the present invention.

Fig. 5 is a schematic illustration of an alternative apparatus used in producing the fiber product
10 of the present invention.

Fig. 6 is a schematic illustration of another apparatus for producing the fiber product of the present invention.

Detailed Description of the Preferred Embodiments

15 The present invention is a fiber product comprised of treated discontinuous natural fibers. The term natural fibers refers to fibers which are naturally occurring, as opposed to synthetic fibers. Non-cellulosic natural fibers are included, with chopped silk fibers
20 being one example. In addition, the term natural fibers includes cellulosic fibers such as wood pulp, bagasse, hemp, jute, rice, wheat, bamboo, corn, sisal, cotton, flax, kenaf, and the like, and mixtures thereof. The term discontinuous fibers refers to fibers of a relatively
25 short length in comparison to continuous fibers treated during an extrusion process used to produce such fibers. The term discontinuous fibers also includes fiber bundles. The term individual fibers refers to fibers that are comprised substantially of individual separated fibers
30 with at most only a small amount of fiber bundles.

Wood pulp fibers can be obtained from well-known chemical processes such as the kraft and sulfite processes. Suitable starting materials for these processes include hardwood and softwood species, such as
35 alder, pine, douglas fir, spruce and hemlock. Wood pulp fibers can also be obtained from mechanical processes, such as ground wood, refiner mechanical, thermomechanical, chemi-mechanical, and chemi-thermomechanical pulp

processes. However, to the extent such processes produce fiber bundles as opposed to individually separated fibers or individual fibers, they are less preferred. However, treated fiber bundles is within the scope of the present invention. Recycled or secondary wood pulp fibers and bleached and unbleached wood pulp fibers can also be used. Details of the production of wood pulp fibers are well-known to those skilled in the art. These fibers are commercially available from a number of companies, including Weyerhaeuser Company, the assignee of the present patent application.

For purposes of convenience, and not to be construed as a limitation, the following description proceeds with reference to thermoplastic binder treated chemical wood pulp fibers. Individual treated fibers of other types, and obtained by other methods, as well as treated fiber bundles, can be obtained in the same manner.

When relatively dry wood pulp fibers are being treated, that is fibers with less than about 10 to 12 percent by weight moisture content, the lumen of such fibers is substantially collapsed. As a result, when binder materials, in particular thermoplastic latex binder materials, are applied to these relatively dry wood pulp fibers, penetration of the binder into the lumen is minimized. In comparison, relatively wet fibers tend to have open lumen through which binder materials can flow into the fiber in the event the fiber is immersed in the binder. Any binder that penetrates the lumen contributes less to the desired characteristics of the treated fiber than the binder which is present on the surface of the fiber. Therefore, when relatively dry wood pulp fibers are treated, less binder material is required to obtain the same effect than in the case where the fibers are relatively wet and the binder penetrates the lumen.

Thermoplastic binder materials used in producing the fibers typically include substances which can be applied in liquid form to entrained fibers during one illustrated treatment process. These binder materials are

- 12 -

capable of subsequently binding the fibers produced by the process to one another or to other fibers during the manufacture of webs and other products using the treated fibers. Most preferably these thermoplastic binders
5 comprise organic polymer materials which may be heat fused at elevated temperatures to bond the fibers when the fibers are used in manufacturing products. Also, in applications where solid particulate material is to be adhered to the fibers by the thermoplastic binder, the
10 binder must be of a type which is suitable for this purpose.

Suitable thermoplastic binders include polymeric materials in the form of aqueous emulsions or solutions and nonaqueous solutions. To prevent agglomeration of
15 fibers during the illustrated treatment process, preferably the total liquid content of the treated fibers during treatment, including the moisture contributed by the binder together with the liquid content of the fibers (in the case of moisture containing fibers such as wood
20 pulp), must be no more than about 45 to 55 percent of the total weight, with a 25 to 35 percent moisture content being more typical. Assuming wood pulp is used as the natural fiber, the moisture contributed by the wood pulp can be higher, but is preferably less than about 10 to 12
25 percent and more typically about six to eight percent. The remaining moisture or liquid is typically contributed by the binder. These polymer emulsions are typically referred to as "latexes." In the present application, the term "latex" refers very broadly to any aqueous emulsion
30 of a thermoplastic polymeric material. The term solution means binders dissolved in water or other solvents, such as acetone or toluene. Polymeric materials used in binders in accordance with the present method can range from hard rigid types to those which are soft and rubbery.
35 The thermoplastic polymers may be a material which remains permanently thermoplastic. Alternatively, such polymers may be of a type which is partially or fully cross-linkable, with or without an external catalyst, into

- 13 -

a thermosetting type polymer. As a few specific examples, suitable thermoplastic binders can be made of the following materials:

5 ethylene vinyl alcohol
polyvinyl acetate
acrylic
polyvinyl acetate acrylate
acrylates
10 polyvinyl dichloride
ethylene vinyl acetate
ethylene vinyl chloride
polyvinyl chloride
styrene
styrene acrylate
15 styrene/butadiene
styrene/acrylonitrile
butadiene/acrylonitrile
acrylonitrile/butadiene/styrene
ethylene acrylic acid
20 polyethylene
urethanes
polycarbonate
polyphenylene oxide
polypropylene
25 polyesters
polyimides

Surfactants may also be included in the liquid thermoplastic binder as desired. Other materials may also be mixed with the liquid binder to impart desired
30 characteristics to the treated fibers.

Certain types of binders enhance the fire resistance of the treated fibers, and thereby of products made from these fibers. For example, poly vinyl chloride, poly vinyl dichloride and ethylene vinyl chloride are fire
35 retardant.

In addition, the fiber product of the invention may have one or more solid particulate materials adhered to the fibers to provide desired functional

characteristics. The solid particulate materials are typically applied to a binder wetted surface of the fibers and then adhered to the fibers by the binder as the binder dries. In this case, heat fusion of the binder is not
5 used to adhere the particles to the fibers. Although not limited to specific materials, examples of suitable particulate materials include pigments, such as titanium dioxide; fire retardant materials, such as alumina trihydrate and antimony oxide; electrically conductive
10 materials, such as metallic powders and carbon black; abrasive materials, such as ceramics, grit and metallic powders; acidular materials, such as clay, talc and mica, used as paper making additives; oleophilic materials; hydrophobic materials; and hydrophilic materials, such as
15 super absorbent particles; insecticides; and fertilizers. Thus, the solid particulate materials are not limited to narrow categories.

The super absorbent particulate materials are granular or powdered materials which have the ability to
20 absorb liquids, including body fluids. These super absorbents are generally hydrophilic polymeric materials. Super absorbents are defined herein as materials which exhibit the ability to absorb large quantities of liquids, i.e. in excess of 10 to 15 parts of liquid per part
25 thereof. These super absorbent materials generally fall into three classes, namely, starch graft copolymers, cross-linked carboxymethylcellulose derivatives and modified hydrophilic polyacrylates. Without limiting the generality of the term super absorbent, examples of super
30 absorbents include carboxylated cellulose, hydrolyzed acrylonitrile-grafted starch, acrylic acid derivative polymers, polyacrylonitrile derivatives, polyacrylamide type compounds and saponified vinyl acetate/methyl acrylate copolymers. Specific examples of super absorbent
35 particles are marketed under the trademarks "Sanwet" (supplied by Sanyo Kasei Kogyo Kabushiki Kaisha) and "Sumika Gel" (supplied by Sumitomo Kagaku Kabushiki Kaisha).

- 15 -

An abrasive is a hard substance that, in particulate form, is capable of effecting a physical change in a surface, ranging from the removal of a thin film of tarnish to the cutting of heavy metal cross sections and cutting stone. Abrasives are used in scores of different abrasive products. The two principal categories of abrasives are: (1) natural abrasives, such as quartz, emery, corundum, garnet, tripoli, diatomaceous earth (diatomite), pumice, and diamond; and (2) synthetic abrasives, such as fused alumina, silicon carbide, boron nitride, metallic abrasives, and synthetic diamond.

Oleophilic materials are those capable of rapid wetting by oil while hydrophilic materials are those capable of rapid wetting by water.

Pigments or colorants can be broadly defined as capable of reflecting light of certain wavelengths while absorbing light of other wavelengths and which are used to impart color.

Electrically conductive materials are those which readily conduct electric current.

In addition, fire retardant materials are those which reduce the flammability of the fibers to which they are attached. Preferably these materials are active fire retardants in that they chemically inhibit oxidation or they emit water or other fire suppressing substances when burned.

One apparatus for producing the fiber product of the present invention is shown in Fig. 1. With reference to this figure, a sheet of chemical wood pulp 10 is unrolled from a roll 12 and delivered to a refiberizing apparatus, such as a conventional hammer mill 14. The sheet 10 is readily converted into individual fibers 16 within the hammer mill. These individual fibers are delivered, as by a conveyor 18, to a fiber loading zone 20 of a fiber treatment apparatus. In the case of a continuous process, fibers 16 are continuously delivered to the zone 20. In a batch or semi-batch process, fibers are loaded at zone 20 at intervals.

- 16 -

In the Fig. 1 fiber treatment apparatus, loading zone 20 forms part of a fiber treatment conduit 24. The illustrated conduit 24 comprises a recirculating loop. A blower or fan 26 in loop 24 is positioned adjacent to the fiber loading zone 20. Blower 26 is capable of moving a gaseous medium, such as air, at a velocity and volume sufficient to entrain the fibers which have been loaded into zone 20. The entrained fibers circulate in a direction indicated by arrow 28 through the loop and pass through the loading zone 20 and blower 26 each time the loop is traversed.

The velocity of air traveling in the loop is preferably set at a level where solids are uniformly dispersed and transported by the air flow. In addition, the velocity is preferably established at a level which is sufficient to avoid saltation, that is the dropping of solids or liquids from a horizontal air stream. As a specific example, when Type NB316 chemical wood pulp, available from Weyerhaeuser Company, was used as the fiber, a velocity of 5,000 feet per minute worked extremely well in the production of these fibers. However, this velocity can be varied and adjusted for optimum results.

Also, the ratio of the volume of air per pound of entrained fiber is variable over relatively large ranges. One suitable example is 23.4 ft³ of air per pound of fiber. As another example, 11.7 ft³ of air per pound of fiber produced equivalent results. The entrained fibers traveling in the loop pass one or more binder material application zones, with one such zone being indicated in Fig. 1 at 30. This binder material application zone 30 forms a part of the conduit 24. A mechanism is provided at the binder application zone for applying a liquid binder solution to the entrained fibers. In the Fig. 1 form of this mechanism, plural nozzles, in this case nozzles 32, 34 and 36, are used to apply the liquid binder material. These nozzles produce an

- 17 -

atomized spray or mist of binder drops which impact and coat the fibers as the fibers pass the nozzles.

In the Fig. 1 apparatus, plural valves 40, 42 and 44 are operated to control the flow of liquid binder material to the respective nozzles 32, 34 and 36. In the illustrated configuration, a first liquid binder material from a tank or other source 46 is delivered to the three nozzles 32, 34 and 36 when valves 40 and 42 are open and valve 44 is closed. As the fibers recirculate through the conduit 24, and each time they pass the nozzles, an additional amount of the first liquid binder material is applied. Different surfaces of the fibers are exposed to the nozzles 32, 34 and 36 as the fibers travel through the material application zone 30. After the desired amount of the first liquid binder material is applied, the valve 40 is closed. If desired for a particular application, a second liquid binder material from a tank or other source 48 may also be applied to the fibers. With valves 42 and 44 open and valve 40 closed, this second liquid binder material is applied to the fibers through each of the nozzles 32, 34 and 36. In addition, the two liquid binder materials may be simultaneously applied, at successive locations in zone 30. For example, the valve 42 may be closed and valve 44 opened so that the first liquid binder material is applied through nozzles 32, 34 and the second liquid binder material is applied through nozzle 36. More than two types of liquid binder materials may be applied by adding additional binder sources and suitable valving and nozzles.

In general, the material application zone 30 typically ranges from two to one hundred feet long, with longer application zones allowing the application of binder over a longer period of time during passage of fibers through the material application zone. Also, longer material application zones facilitate the use of more nozzles spaced along the length of the zones.

The nozzles 32, 34 and 36 are commercially available and produce a fine mist of droplets. Typically,

- 18 -

these nozzles provide a fan spray. Any suitable nozzles may be used, but it is desirable that the nozzles not produce a continuous stream of liquid binder material, but instead produce droplets or a mist of such material. The
5 nozzles are typically spaced apart from three to four feet along the length of the conduit, although they may be closer or further apart as desired.

Virtually any amount of binder material may be applied to the entrained fibers. However, it has been
10 found that the application of thermoplastic binder must be at a minimum of about seven percent of the dry weight of the combined fibers and binder in order for the fibers to have a substantially continuous sheath or coating of the binder material. If the fibers lack a continuous coating,
15 it becomes more difficult to adhere significant amounts of particulate material to the binder in the manner explained below. In fact, a much higher percentage of binder than this minimum is preferably used to adhere particles to the fibers. Also, exposed portions of the core fiber, that is
20 surface areas of the fiber not coated with the binder, lack the desired characteristics of the binder. For example, if a hydrophobic binder is used to cover a water absorbing cellulose material, failure to completely enclose the material with the coating leaves exposed
25 surfaces of the fiber which can absorb water. Also, any uncoated areas on the fibers would not bond to other untreated fibers during subsequent heat bonding of the treated and untreated fibers.

It has also been found that, with a thermoplastic
30 binder concentration of about 10 percent by dry weight of the weight of the fiber and binder combination, the fibers, when heat fused, will bond somewhat strongly to other fibers coated in a similar manner, but less strongly to untreated fibers. The resulting bond strength is
35 similar to the strength achieved when fibers coated with a 40 percent by dry weight binder amount are mixed with untreated fibers in a ratio of one part treated fiber to three parts untreated fiber. A thermoplastic binder

concentration by dry weight of the combined binder and fibers of from 30 percent to 50 percent has proven extremely suitable for use in mixing with other fibers, heat bonding, and use in forming products such as
5 absorbent pads.

Thermoplastic binder concentrations in excess of 50 percent, for example 90 percent or more, can be achieved utilizing the present invention. To achieve these extremely high binder concentrations, one preferred
10 approach is to apply a first amount of the binder material to the entrained fibers, continue to recirculate the fibers until this first layer or coating of binder material is substantially dry, and then apply a second coating of the binder material. Third, fourth and
15 subsequent coatings can be applied to the entrained fibers as necessary to achieve the desired level of binder material.

Following the application of the liquid thermoplastic binder material to the fibers, the fibers
20 may be retained in the loop until they have dried. The recirculation of the fibers may then be stopped and the fibers removed at the loading zone 20 which then functions as a fiber removal location. However, in the Fig. 1 apparatus, a cyclone separator 60 is selectively connected
25 by a conduit section 61 and a gate valve 62 to the conduit 24. At the same time a valve 64 is opened to allow air to enter the loop 24 to compensate for air exiting through the separator 60. With the separator in the loop, the entrained fibers are collected in the separator and then
30 removed from the separator at a fiber removal outlet 66. A substantial majority of the fibers processed in this manner are unbonded to one another by the binder material. By substantial majority, it is meant that at least about 70 percent of the fibers remain unbonded. More
35 specifically, in tests conducted as of this time, the resulting treated fibers are substantially unbonded, meaning that approximately 95 percent of the treated

- 20 -

fibers have been found to be unbonded to one another by the binder material.

An optional means for heating the binder coated fibers may be included in conduit 24. For example heated
5 air may be blended with the air flowing through the conduit. Similarly, a heater 70 may be included in conduit 24 for heating the fibers. This added heat accelerates the drying of the liquid binder. The fibers are preferably heated above the film forming temperatures
10 of the thermoplastic heat fusible binder and below the hot tack temperature at which the binder becomes tacky. Thereafter, the binder coated fibers may subsequently be heat fused during processing of the fibers into products.

The fibers are preferably not heated prior to the
15 application of the thermoplastic binder material. It has been found that heating the fibers results in elevated temperatures at the binder application zone 30. These elevated temperatures cause some of the binder to at least partially dry (coalesce) before reaching surfaces of
20 fibers passing through the binder application zone 30. The solidified binder tends to either not adhere or only adhere weakly to the fibers. In addition, droplets of binder which impinge heated fibers tend to dry in globules on the fibers, rather than spread across the surface of
25 the fibers to provide a substantially continuous uniform coating thereon.

The dried fibers from outlet 66 of the cyclone separator 60 may be deposited in a conventional baling apparatus 72. To prevent bonding of the fibers in the
30 baler, the fibers are at a temperature which is below their curing or tack temperature under the pressure applied by the baler. When compressed, these fibers remain unbonded by the binder material and therefore can be readily separated into individualized fibers for
35 subsequent use.

Also, treated fibers which have only been partially dried, and thus which are still somewhat wet with the thermoplastic binder material, may be deposited

- 21 -

from outlet 66 loosely onto a conveyor 74 or in a loose uncompressed pile at a collecting zone (not shown). These fibers can then be allowed to dry. Alternatively, the treated fibers may be carried by the conveyor 74 through a
5 heater 76, operable like heater 70, to accelerate the drying of the fibers. The resulting product again contains a major portion of unbonded fibers. However, the wetter the fibers and more dense the resulting web when deposited on belt 74, or in a pile, the more binder-to-
10 binder bonds that occur. Thus, in many cases it is preferable to at least partially dry the fibers within the conduit 24 prior to removing the fibers therefrom. However, the fiber may be air laid either dry or wet, that is, with no more than about a 55 percent total moisture
15 content in the fibers and binder thereon, directly into a web which can then be processed into various products, such as into disposable diapers with the core of the diaper being formed by the web. Air laying refers to the transfer of the fibers through air of another gaseous
20 medium.

Solid particulate materials may be adhered to the fibers by the binder material.

To accomplish this, the solid particulate material is added to the loop 24, such as at the fiber
25 loading zone 20. The particles may also be added to the loop 24 from a supply housing 80, using a feed screw metering device or other conventional injection mechanism. Preferably, the particles are added after the fibers have been wetted with the binder material. Consequently, the
30 particles will not be covered with the binder material, which could interfere with the desired attributes contributed by the particles. These particles contact the wet binder material on the surfaces of the fibers and stick to the binder material. As the binder material
35 dries, the particles remain stuck the surface of the treated fibers. In one specific approach, the fibers are treated with a binder, circulation of the fibers is stopped momentarily to allow the addition of the solid

- 22 -

particulate material at the fiber loading zone 20, and recirculation and entrainment of the fibers is recommenced. The particles mix with and are secured to the surface of the fibers by the liquid binder material as the binder dries. Although lower concentrations are effective in binding particles to fibers, it has been found that relatively high levels of binder concentrations, for example 20 percent or more of the dry weight of the binder, fiber and additive, produces the best adhesion of particles to the fibers. A 50 percent binder concentration would perform better in adhering particles to the fibers than a 20 percent binder concentration in many applications. These higher binder levels, when heat fusible binders are used, facilitate subsequent heat fusion of the fibers and strong bonding, with or without other fibers being added, during use of the fibers in manufacturing products.

The Fig. 1 apparatus may be operated in a batch mode in which fibers are introduced, fully treated and removed. Alternatively, a semi-batch approach may be used in which fibers are added and some, but not all, of the fibers removed from the loop. Also, the Fig. 1 apparatus may be operated in a continuous mode in which fibers are introduced at zone 20 and removed by the cyclone separator 60 with or without recirculating through the loop. The gate valves 62, 64 may be opened to a desired extent to control the amount of fiber that is removed. This quantity of removed fiber is preferably equal to the amount of untreated fiber that is introduced into the loop. In this nonrecirculating case, the zone 30 is typically expanded.

With reference to Figs. 2 and 3, another mechanism for applying binder material to the fibers is illustrated. Rather than using external spray nozzles such as 32, 34 and 36, plural nozzles (i.e., one being shown as 82 in Figs. 2 and 3) are included in the conduit at the binder material applying zone 30. The nozzle 82 applies a fine spray of liquid binder material onto the

- 23 -

fibers 16 as they move past the nozzle. The Figs. 2 and 3 binder applying mechanism includes a means for imparting turbulence to the air as it passes the nozzles. As a result, the fibers 16 tend to tumble in front of the
5 nozzles and expose different surfaces to the applied binder material. The illustrated turbulence imparting mechanism comprises a blunted conical air deflection baffle 86 supported within the conduit 24 by rods, with two such rods 88 and 90 being shown. Rod 90 may be hollow
10 to provide a pathway through which binder material is delivered to the nozzle 82. Of course, other turbulence imparting mechanisms may also be used.

In Fig. 4, a rotary mixer 90 with plural mixing paddles, some being indicated at 92, is disposed within
15 the conduit 24 at the material applying zone 30. This mixer is rotated by a motor (not shown) to impart turbulence to fibers as they pass the mixer paddles. The nozzles 32, 34 and 36 are disposed externally of the conduit 24 for directing the binder material through ports
20 to the fibers passing the mixer. These nozzles may be enclosed in a shroud or cover as shown by dashed lines 94 in this figure. However, in the Fig. 4 approach, blower 26 has been shifted to a location downstream from the material applying zone 30. Consequently, the material
25 applying zone is at a relatively low pressure with a slight vacuum being present in the material applying zone relative to the pressure outside the conduit at this zone. Consequently, fibers passing the nozzles 32, 34 and 36 tend to be drawn into the conduit rather than escaping
30 through the binder applying ports. As a result, the nozzles can be positioned outside of the conduit where they are not subject to being clogged by the passing fibers.

Referring to Fig. 5, another apparatus is shown
35 for producing the fiber product of the present invention. In Fig. 5, for purposes of convenience, elements in common with those of Fig. 1 have been given like numbers and will not be discussed in detail.

- 24 -

In general, the Fig. 5 form of the apparatus allows the continuous processing of fibers with the fibers passing only once through the binder material application zone 30. However, the zone 30 is typically of an extended length with more nozzles (i.e. six to twelve or more) than shown in Fig. 5. Following the application of the binder material, solid particulate material may be added from source 80, such as by a blower (not shown) or a feed screw, to introduce the particles into the stream of entrained fibers. The fibers pass through a heater or oven 70, or heated air is blended with the air stream which entrains the fibers, for drying purposes and then travel through a distance D at the elevated temperatures created by this heat. As a typical example, D may be 150 feet with the time required to travel the distance D enabling the binder on the entrained fibers to become substantially dry. Optionally, cooling air from a refrigeration unit 100 or ambient air from the environment may be delivered by a blower 102 to the conduit 24 at a location 104 in the conduit. This cooling air lowers the temperature of the dried and treated fibers. The cooling air may be dehumidified prior to introduction to conduit 24 to minimize any condensation that may otherwise occur in the conduit. Again, the temperature is preferably kept above the film forming temperature and below the hot tack temperature of the thermoplastic binder material. Cyclone separator 60 may be provided with a bleed line 106 for venting the air during separation. Although less preferred, this air may be recirculated back to the fiber loading zone 20. Flow control gate valves 107, 109 may be included in the system to balance the air flow through the various conduits of the illustrated system.

The treated fibers from outlet 66 of the separator 60 may be fed to a hopper 110 of a conventional fiber blending unit 112. Other fibers, such as wood pulp fibers or synthetic fibers are fed, in a desired proportion for the resulting product, by way of a conduit 114 to another hopper 116 and then to the blending unit

- 25 -

112. The fibers from outlet 66 can also be used without blending them with other fibers. The blended treated and untreated fibers 118 are shown being deposited on a facing sheet 120 which is passed through the blending unit 112 from a roll 122. The fibers may also be deposited directly on a conveyor without a facing sheet. The facing sheet is carried by a conveyor 124 through the blending unit 112. The composite web is then passed through a thermobonding unit 130 which raises the temperature of the fibers sufficiently to cause the treated fibers to heat fuse to the other fibers and to the facing sheet. The fibers may be compressed to densify the web prior to or after delivery to the thermobonder 130. A cover sheet may also be added to the product before or after the thermobonder 130. Following thermobonding, to reduce the stiffness of the webs, they may be "tenderized" by the use of a mechanism which mechanically breaks up some of the bonds in the web. The web still remains substantially bonded, however. As one example, the webs may be passed through the nips of cross machine direction and machine direction corrugators to reduce their stiffness. The stiffness can be controlled by adjusting the clearance between the nips. Although not limited to a specific approach, examples of suitable corrugators and tenderizing procedures are disclosed in U.S. Patent Nos. 4,559,050, 4,596,567 and 4,605,402. The resulting material can be used in a conventional manner to manufacture a wide variety of products, such as webs, absorbent pads, disposable diapers, webs and the like.

In the Fig. 6 form of apparatus used to produce the fiber product of the present invention, the fibers to be treated may be delivered in loose form or in the form of a sheet 10 from roll 12 to a first hammer mill or refiberizing device 140. The resulting fibers travel through air or another gaseous medium in conduit 24 and through a binder applying zone 30. If the fibers are not conveyed horizontally, but merely pass downwardly in the conduit, the air velocity need not be as high. In this

- 26 -

sense the fibers are not air entrained, but merely travel through the conduit. At zone 30, a first binder material 46 is applied to the fibers by way of nozzle 32. Again, this is a schematic representation of the apparatus, as plural nozzles are preferably employed and more than one type of binder may be used. Thus, the material applying zone is substantially elongated over that which is shown. One or more particulate materials may also be added to the binder coated fibers from a source of such particles 80.

10 The treated fibers may be air laid or otherwise deposited, wet or dry, directly on a face sheet 120 from a roll 122 or directly on a conveyor. Typically a vacuum (not shown) would be used to draw the fibers against the screen so that the fibers are not simply falling under the influence of gravity. The face sheet is carried by a conveyor 124 past an outlet 146 of the fiber treatment apparatus. A web of untreated fibers 148 from a roll 150 is optionally delivered to another hammer mill 152 for fiberization and blending with the treated fibers prior to depositing the blend on the face sheet 120. The face sheet 120 and deposited fibers may then be processed, such as previously described, for use in manufacturing a variety of products.

The following examples will serve to more specifically illustrate the method of the present invention, although it is to be understood that the invention is not limited to these examples.

EXAMPLE 1

A bleached Kraft Southern Pine cellulose fiber pulp sheet (NB-316 from Weyerhaeuser Company) was fiberized in a hammer mill. One kilogram of the fiberized fluff was then air entrained in a recirculating conduit. After 20 seconds of air entrainment, 1223 grams of Primacor 4990 ethylene acrylic acid copolymer solution, 35 percent solids, was sprayed onto the air entrained fiber over a period of eight minutes. Primacor 4990 is a thermoplastic binder material which is available from Dow Chemical Corporation. The coated fiber was then recirculated for two minutes prior to separation in a

- 27 -

cyclone. The still somewhat wet coated fiber was then deposited in a loose pile and air dried at room temperature for 24 hours. Even though wood fibers are of irregular cross-section and thus more difficult to coat than surfaces with a regular cross section or smooth surface, the resultant fibers had a uniform continuous coating of binder. Also, approximately 95 percent of the fibers were unbonded to one another by the binder material. The dried fiber was then easily air laid in a laboratory pad former. Six inch diameter pads weighing ten grams were prepared. These pads were then compressed in a press to densities of from 0.04 to 0.15 g/cm³ and then thermobonded at 140 degrees Centigrade in an air-through laboratory bonding unit. The resulting pads were tested for tensile index (tensile strength in N/m divided by basis weight in g/m²). The tensile index was 0.6 N-m/g for pads having a density of 0.06 g/cc.

In addition, the dried coated fiber obtained in this manner was blended with uncoated fiber in a ratio of 1/3 coated fibers to 2/3 uncoated NB-316 fibers. The blend was air laid and thermobonded. The tensile index of the blend was 0.3 N-m/g at a 0.06 g/cc density. Primacor is a hydrophobic, somewhat oleophilic thermoplastic binder. Therefore, a Primacor coated fiber is capable of absorbing oil without water.

A wide variety of other binders have also been tested, including Synthemul 40-800 and 40-850 emulsions, available from Reichhold Chemical Corporation. Cellulose wood pulp fibers having 5 percent, 7 percent, 10 percent, 20 percent, 30 percent and 50 percent by dry weight Synthemul 40-800 coating have been manufactured using the present method. It is only at levels of about 7 percent that a continuous coating of the fibers is achieved. At 5 percent, the binder material was present as non-interconnected areas or blobs on the surface of the fibers. These percentages are the percent of dry weight of the fiber and binder combination which is the binder. In a recirculating system, to achieve higher percentages

- 28 -

of the binder concentration, the fibers were recirculated in the loop during liquid binder application for a longer time. Pads made in the above manner with 35 percent and 45 percent Synthemul 40-800 binder, respectively, had
5 tensile indices of respectively 1.98 and 1.99 N-m/g at a 0.06 g/cc density. Synthemul is a more hydrophilic binder than Primacor. Also, Elvace 40-712, available from Reichhold Chemical Corporation, an ethylene vinyl acetate,
10 materials. These tests have all confirmed that substantially unbonded individualized fibers coated with a substantially continuous coating of binder material can be produced in accordance with this approach.

EXAMPLE 2

15 This example is similar to example 1, with the exception that a larger volume of fibers were treated at one time. In addition, a surfactant material was added to the Primacor for application with the binder. In this specific example, Aerosol OT-S Dioctyl Sodium
20 Sulfosuccinate 70.2 percent TS, available from American Cyanamid Corporation, was used as the surfactant material. A four kilogram batch of treated NB-316 fluff was processed as explained in example 1. Sufficient Primacor was added to generate a mixture that was 80 percent NB-316
25 wood pulp fibers, 20 percent Primacor with 1.74 percent surfactant based on the Primacor solids. The treated fibers were recirculated in the loop for 15 seconds following the application of the Primacor and then dumped in a pile for subsequent drying. Again, substantially
30 unbonded individualized fibers resulted.

EXAMPLE 3

In accordance with this example, functional materials in particulate form are adhered to the binder coated fibers. It has been found that a binder
35 concentration of 7 percent will adhere some particulate material to the fibers, but at binder concentrations of 20 percent of the total dry weight of the binder, fiber and additives, and higher, much better adhesion occurs.

- 29 -

Fibers were produced in a recirculating loop of the form shown in Fig. 1. In processing the fibers, a sufficient amount of binder material was added to the air entrained fibers to produce the desired concentration.

5 The recirculation blower was then momentarily turned off and the particulate material was added to the system at the fiber loading zone 20. Recirculation of the materials through the loop was then recommenced to mix the particles with the still wet and entrained fibers. Continued
10 circulation of the fibers resulted in partial drying of the binder and adhesion of the particle to the fibers.

In a first more specific example, fibers coated with 20 percent Synthemul 40-800 (the percentage being the percent of binder in the dry fiber, pigment and binder
15 combination) were mixed with a granular pigment material, specifically titanium dioxide. Various amounts of titanium dioxide have been added to the fibers, including an amount which is sufficient to be 50 percent of the dry weight of the binder, fiber and titanium dioxide
20 combination. This material is useful in paper making processes.

Similarly, fire retardant particulate materials, such as alumina trihydrate and antimony oxide may be adhered to binder treated fibers for use in preparing fire
25 retardant materials, such as pads, paper and other products.

To produce an electrically conductive material, a conductive particulate material (such as 60-80 percent by weight of the binder fiber and additive combination) may
30 be adhered to the fibers by the binder. Powdered metallic materials and carbon black are examples.

For use in manufacturing abrasive pads and the like, abrasive particulate materials, such as ceramic powders, metallic powders, or grit, may be secured to the
35 fibers by the binder material.

Also, paper making additives, such as acidular particles of clay, talc, mica and so forth, may be adhered to the fibers. For example, approximately 50 percent by

- 30 -

weight of the binder, fiber and additive content may be made up of these additives.

Oleophilic materials, such as polynorbornene in a desired concentration may be adhered to the fibers.

5 Norsorex from Norsorlor, a division of CdF Chimie of Paris, France, is one example of such a material. Typically a fugitive surfactant is used in this case. Like the other particulate materials, these materials may be added in varying percentages.

10 In addition, more than one type of particle may be bound to the fibers if the functional characteristics of more than one particulate material are desired.

Again, preferably the binder is of a polymeric heat bondable thermoplastic type so that the fibers may be
15 subsequently heat bonded, with or without other fibers, in manufacturing a product.

EXAMPLE 4

This example is like example 3, except that super absorbent particles are adhered to the fibers by the
20 binder material. These super absorbent particles are well known in the art. Various amounts of super absorbent particles have been successfully adhered to the fibers, including from 15-50 percent of the dry weight of the resultant fiber, binder and additive combination. Lower
25 percentages are also possible as are higher percentages. A specific example of super absorbent particulate material is Sanwet LM-1000, available from Celanese Corporation.

In one more specific example of the method, rather than stopping the fibers to permit addition of the
30 particulate material, super absorbent particles were fed into the air stream containing the entrained fibers immediately following the binder application zone. The resultant material had fiber bonded to the super absorbent particles so as to contain the super absorbent particles
35 in the resultant fluff. Yet, the fibers which were not attached to the particles were substantially unbonded to one another. The dried fluff was then air laid into a web and thermobonded. The web was tested for absorbency and

- 31 -

found to be equivalent to an unbonded product, but with virtually 100 percent containment of the super absorbent particles. In addition, the containment of the super absorbent particles within the fibers prior to

5 thermobonding was also excellent. Also, a very uniform distribution of super absorbent particles was present in the resulting web and enhanced the water absorbing characteristics of the web. Consequently, the fibers can be stored and transported for subsequent use in products

10 without significant loss or migration of super absorbent particles.

EXAMPLE 5

In accordance with this example, the thermoplastic binder can be mixed with a blowing agent,

15 such as Azodicarbonamid, and applied to the entrained fibers. When the fibers are subsequently heated, nitrogen, carbon dioxide, and/or other gases would be released to produce a foamed coating of the fibers. These foam coated fibers can then be used in manufacturing, such

20 as in the manufacturing of insulated paper board.

EXAMPLE 6

In accordance with this example, the thermoplastic binder material may be a hydrophobic latex material with a fugitive surfactant with the particles

25 hydrophobic; the binder may be of a hydrophobic material with the particles hydrophilic; the binder may be a hydrophilic material with the particles hydrophobic; or the binder may be a hydrophilic material with the particles hydrophilic. A fugitive surfactant is typically

30 used when water based binders are used and the fibers or particles are hydrophobic.

Thus, a binder such as Primacor may be used with hexanol as a surfactant as explained in connection with example 1 as a hydrophobic binder. While Primacor does

35 have a tendency to absorb oil to a limited extent, it is not an optimum oil absorbing material. By attaching polynorbornene particles to the fibers, fibers having an enhanced capacity for oil absorption may be produced as

the polynorbornene in effect acts like a super absorbent for oil.

An example of a hydrophobic binder with a hydrophilic particulate material would be fibers coated with Primacor with super absorbent particles adhered to the fibers by the binder. For example, fibers containing a 20 percent Primacor binder, 40 percent by weight super absorbent particles, and 40 percent by weight fiber, have been produced. These percentages are of the total dry weight of the binder, fiber and additive combination.

An example of a hydrophilic binder with hydrophobic particles would be Synthemul 40-800 as a binder and polynorbornene as the particles.

Finally, an example of a hydrophilic binder with hydrophilic particles is Synthemul 40-800 as a binder and super absorbent particles as the hydrophilic material.

EXAMPLE 7

The binder may also be comprised of a thermoplastic polymer material together with plasticizer particles or liquid which cause the polymer to soften when subjected to heat. A specific example of liquid plasticizer is dioctyl phthalate. A specific example of a particulate plasticizer is sold under the brand name Santowax from Monsanto, Inc.

EXAMPLE 8

In accordance with this example, the fibers may be coated with plural binder materials. For example, Kraton, a styrene butadiene block copolymer, available from Shell Chemical Corporation is a hydrophobic and oleophilic binder material. This material does not form very strong bonds with other fibers. Therefore, a highly bondable first thermoplastic coating, such as of Primacor may be applied to continuously coat the fibers. Kraton in a lesser amount may then be applied to only partially coat the fibers. The exposed Primacor coated areas then enhance the bondability of these fibers.

- 33 -

EXAMPLE 9

This example demonstrates the applicability of the process to cellulose fibers containing fiber bundle material. Specifically, 1111 grams of a mechanically
5 fiberized wood (10 percent moisture) were placed in a recirculating conduit 24 with an in-line blower. The blower was turned on and the wood fibers became air entrained. 952 grams of Reichhold's Synthemul 40-800 (55 percent moisture) were sprayed onto the fiber through a
10 port in the conduit. After addition of the latex, the material was shunted out of the loop 24, collected in a cyclone 60 and spread on a bench to air dry. Subsequent examination under a scanning electron microscope showed individual fibers and individual fiber bundles enclosed in
15 a latex sheath with substantially no fiber to fiber, fiber to fiber bundle, or fiber bundle to fiber bundle agglomeration due to latex bonding.

Having illustrated and described the principles of our invention with reference to several preferred
20 embodiments and examples, it should be apparent to those of ordinary skill in the art that such embodiments of our invention may be modified in detail without departing from such principles. We claim as our invention all such modifications as come within the true spirit and scope of
25 the following claims.

CLAIMS

1. A fiber product which comprises discontinuous natural fibers coated with a thermoplastic binder material which is at least about seven percent of the combined weight of the thermoplastic binder material and fibers, a substantial majority of the fibers being unbonded.
2. A fiber product according to claim 1 coated with a thermoplastic binder material in an amount of at least ten percent of the combined weight of the thermoplastic binder material and fibers.
3. A fiber product according to claim 1 coated with a thermoplastic binder material in an amount of at least thirty to fifty percent of the combined weight of the thermoplastic binder material and fibers.
4. A fiber product according to claim 1 having a second solid particulate material adhered to the fibers by the thermoplastic binder material.
5. A fiber product according to claim 4 in which the second solid particulate material comprises a pigment material.
6. A fiber product according to claim 5 in which the second solid particulate material comprises TiO_2 .
7. A fiber product according to claim 4 in which the second solid particulate material comprises a fire retardant material.
8. A fiber product according to claim 4 in which the second solid particulate material comprises an electrically conductive material.
9. A fiber product according to claim 8 in which the second solid particulate material comprises a metallic powder.
10. A fiber product according to claim 8 in which the second solid particulate material comprises carbon black.

11. A fiber product according to claim 4 in which the second solid particulate material comprises an abrasive material.

12. A fiber product according to claim 11 in
5 which the abrasive material is ceramic.

13. A fiber product according to claim 4 in which the solid particulate material is an oleophilic material.

14. A fiber product according to claim 4 in
10 which the second solid particulate material is a paper making additive selected from the group comprising clay, talc and mica.

15. A fiber product according to claim 11 in which the natural fibers are chemical wood pulp fibers.

16. A fiber product according to claim 15 in
15 which a second solid particulate material is adhered to the fibers by the thermoplastic binder material.

17. A fiber product according to claim 16 in
20 which the thermoplastic binder material is present in an amount which is at least twenty percent of the combined weight of the thermoplastic binder material and fibers.

18. A fiber product according to claim 17 in which the fibers are substantially unbonded.

19. A fiber product according to claim 4 in
25 which the thermoplastic binder material is a hydrophobic material and the second solid particulate material is a hydrophilic material.

20. A fiber product according to claim 4 in
30 which the thermoplastic binder material is a hydrophobic material and the second solid particulate material is a hydrophobic material.

21. A fiber product according to claim 4 in
35 which the thermoplastic binder material is a hydrophilic material and the second solid particulate material is a hydrophilic material.

22. A fiber product according to claim 4 in which the thermoplastic binder material is a hydrophilic

- 36 -

material and the second solid particulate material is a hydrophobic material.

23. A fiber product according to claim 4 in which the thermoplastic binder material is selected from
5 the group consisting essentially of a polymer and a plasticizer and the second solid particulate material is of the other material from this group.

24. A fiber product according to claim 1 including a second thermoplastic material in addition to
10 the thermoplastic binder material.

25. A fiber product according to claim 1 air laid into a web.

26. A fiber product according to claim 25 in which the thermoplastic binder material in the web is
15 initially at least partially wet.

27. A fiber product according to claim 26 in which the web contains coated fibers mixed with other noncoated fibers.

28. A fiber product according to claim 25 in
20 which the web contains coated fibers mixed with other noncoated fibers.

29. A fiber product according to claim 25 in which the web is heat bonded.

30. A fiber product according to claim 26 in
25 which the web is heat bonded.

31. A fiber product according to claim 27 in which the web is heat bonded.

32. A fiber product according to claim 28 in which the web is heat bonded.

30 33. A fiber product according to claim 4 air laid into a web.

34. A fiber product according to claim 33 in which the thermoplastic binder material in the web is initially at least partially wet.

35 35. A fiber product according to claim 34 in which the web contains coated fibers mixed with other noncoated fibers.

- 37 -

36. A fiber product according to claim 33 in which the web contains coated fibers mixed with other noncoated fibers.

37. A fiber product according to claim 33 in
5 which the web is heat bonded.

38. A fiber product according to claim 34 in which the web is heat bonded.

39. A fiber product according to claim 35 in which the web is heat bonded.

10 40. A fiber product according to claim 36 in which the web is heat bonded.

41. A fiber product which comprises discontinuous cellulose fibers coated with a substantially continuous coating of a thermoplastic binder material, a
15 substantial majority of the fibers being unbonded.

42. A fiber product according to claim 41 in which the fibers are substantially unbonded.

43. A fiber product according to claim 42 in which the fibers are mixed with other fibers and the mixed
20 fibers are heat bonded.

44. A fiber product according to claim 41 in which the fibers are mixed with other fibers and the mixed fibers are heat bonded.

45. A fiber product according to claim 41 in a
25 second solid particulate material is adhered to the fibers by the thermoplastic binder material.

46. A fiber product according to claim 41 in which the discontinuous cellulose fibers include both individual cellulose fibers and cellulose fiber bundles,
30 the individual fibers and fiber bundles being coated with a substantially continuous coating of a thermoplastic binder material, a substantial majority of the individual fibers and fiber bundles being unbonded.

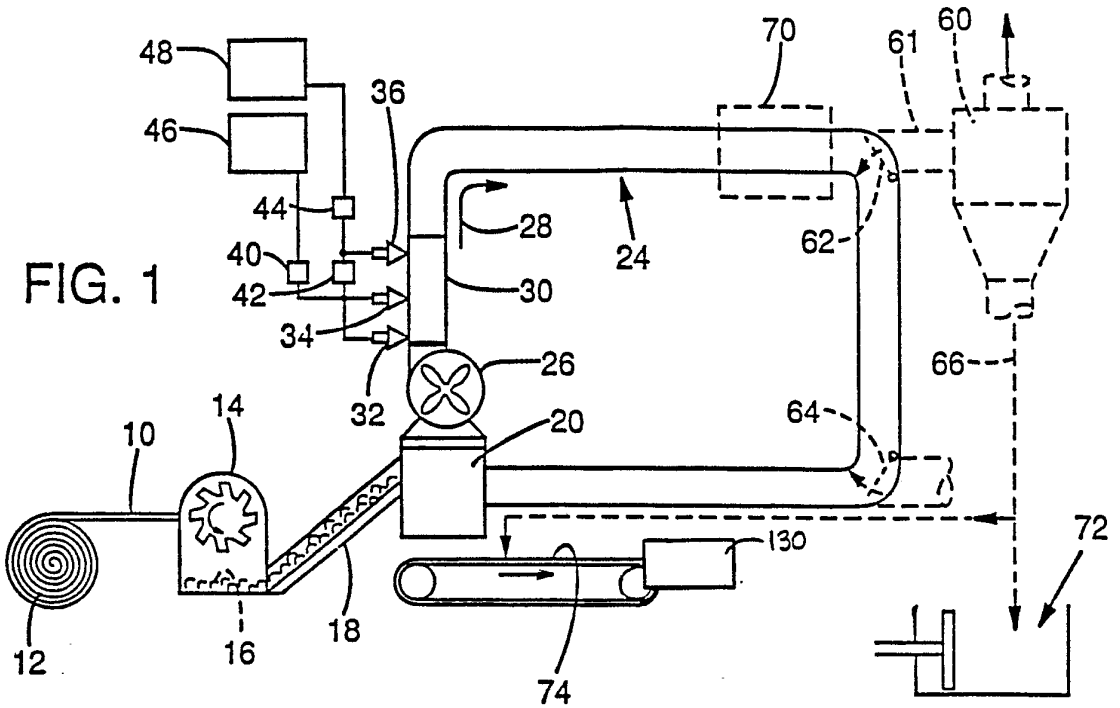

FIG. 1

FIG. 2

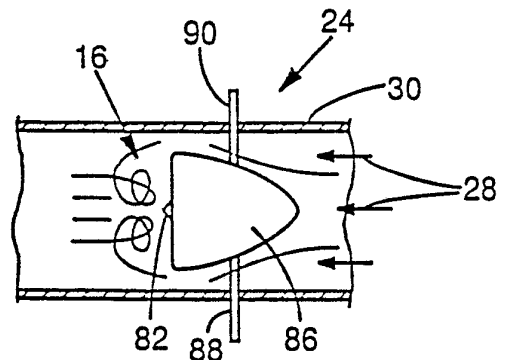

FIG. 3

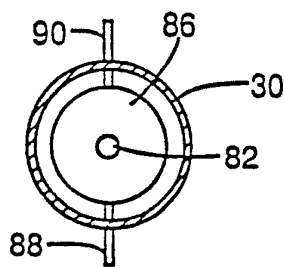
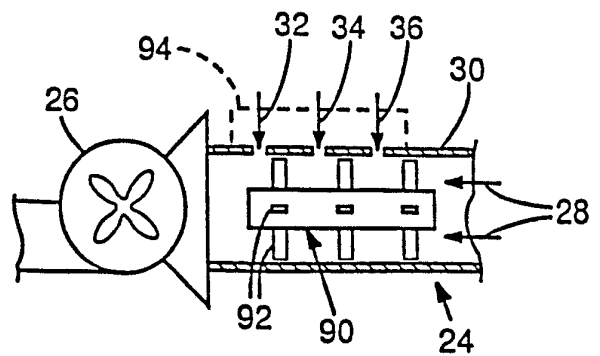
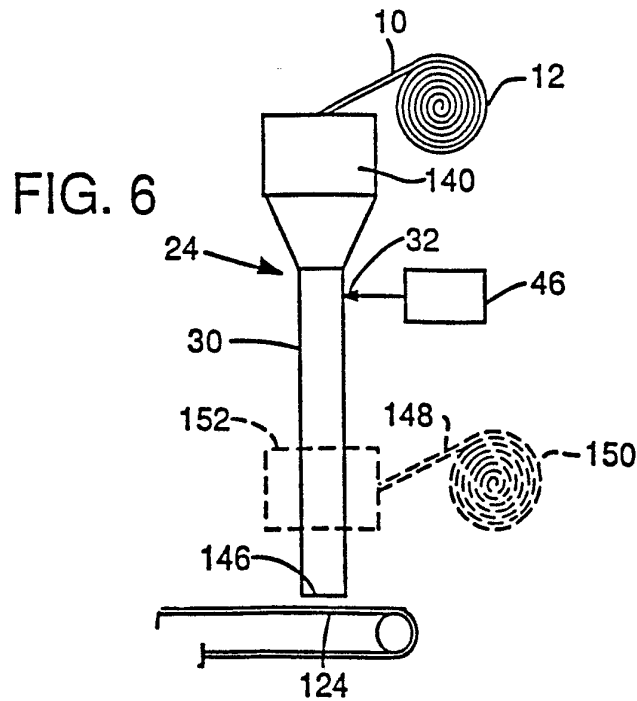
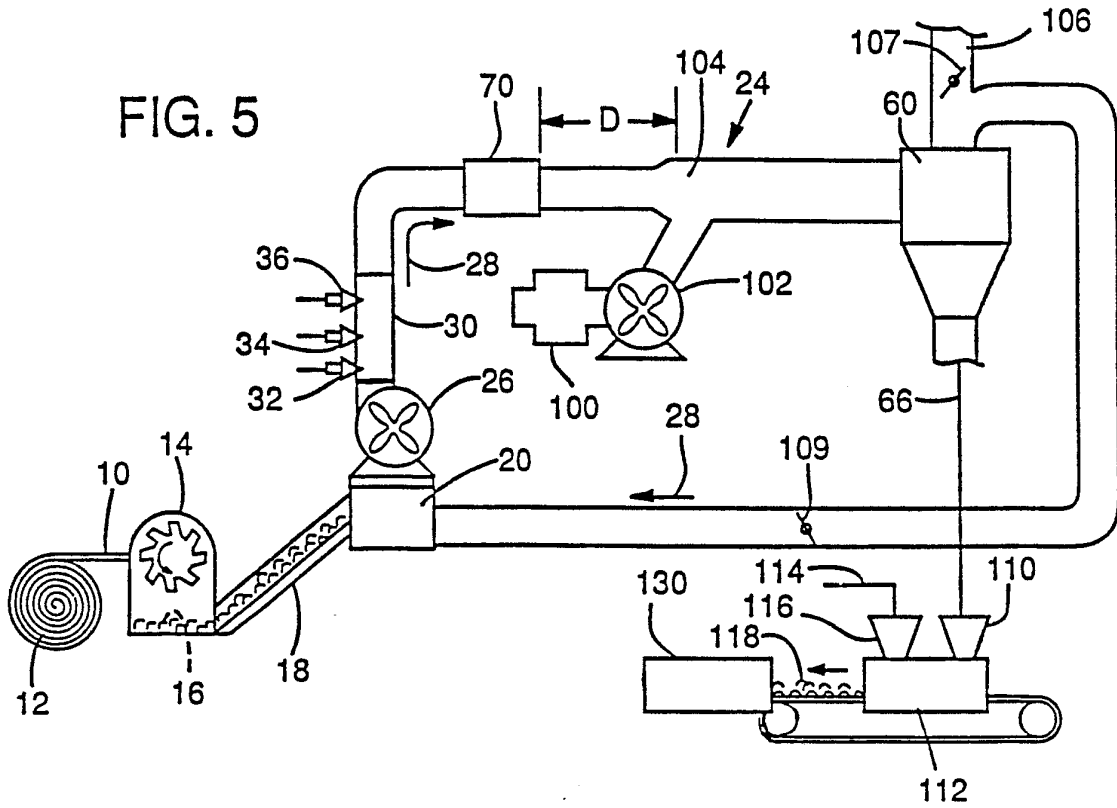

FIG. 4





INTERNATIONAL SEARCH REPORT

International Application No PCT/US90/01591

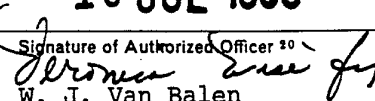
I. CLASSIFICATION OF SUBJECT MATTER (if several classification symbols apply, indicate all) ³		
According to International Patent Classification (IPC) or to both National Classification and IPC		
Int Cl 5	B27K 3/00	
US Cl	162/157.1, 164.6, 182; 428/361,375	
II. FIELDS SEARCHED		
Minimum Documentation Searched ⁴		
Classification System	Classification Symbols	
US	162/157.1, 164.6, 182 428/361, 375	
Documentation Searched other than Minimum Documentation to the Extent that such Documents are Included in the Fields Searched ⁵		
III. DOCUMENTS CONSIDERED TO BE RELEVANT ¹⁴		
Category [*]	Citation of Document, ¹⁶ with indication, where appropriate, of the relevant passages ¹⁷	Relevant to Claim No. ¹⁸
Y	US,A, 2,601,597 (Daniel) 24 JUNE 1952; See entire document	1-46
Y	US,A, 4,428,843 (Cowan) 31 JANUARY 1984; See entire document	1-46
Y	US,A, 4,584,357 (Harding) 22 APRIL 1986; See entire document	1-46
<p>[*] Special categories of cited documents: ¹⁵</p> <p>"A" document defining the general state of the art which is not considered to be of particular relevance</p> <p>"E" earlier document but published on or after the international filing date</p> <p>"L" document which may throw doubts on priority claim(s) or which is cited to establish the publication date of another citation or other special reason (as specified)</p> <p>"O" document referring to an oral disclosure, use, exhibition or other means</p> <p>"P" document published prior to the international filing date but later than the priority date claimed</p> <p>"T" later document published after the international filing date or priority date and not in conflict with the application but cited to understand the principle or theory underlying the invention</p> <p>"X" document of particular relevance; the claimed invention cannot be considered novel or cannot be considered to involve an inventive step</p> <p>"Y" document of particular relevance; the claimed invention cannot be considered to involve an inventive step when the document is combined with one or more other such documents, such combination being obvious to a person skilled in the art.</p> <p>"&" document member of the same patent family</p>		
IV. CERTIFICATION		
Date of the Actual Completion of the International Search ²		Date of Mailing of this International Search Report ²
01 JUNE 1990		18 JUL 1990
International Searching Authority ¹		Signature of Authorized Officer ²⁰
ISA/US		 W. J. Van Balen