



US00D972729S

(12) **United States Design Patent**
Morton et al.

(10) **Patent No.:** **US D972,729 S**

(45) **Date of Patent:** **** Dec. 13, 2022**

- (54) **DETECTOR HOLDER COUPLER RING**
- (71) Applicant: **Surround Medical Systems, Inc.**,
Morrisville, NC (US)
- (72) Inventors: **Trent Morton**, Morrisville, NC (US);
William Knestrick, Raleigh, NC (US)
- (73) Assignee: **Surround Medical Systems, Inc.**,
Morrisville, NC (US)
- (**) Term: **15 Years**
- (21) Appl. No.: **29/782,193**
- (22) Filed: **May 5, 2021**
- (51) **LOC (13) Cl.** **24-01**
- (52) **U.S. Cl.**
USPC **D24/161**
- (58) **Field of Classification Search**
USPC D24/158-161, 152, 176, 177, 186, 187,
D24/128; 378/180, 191, 205, 208
CPC A61B 6/145; A61B 6/4435; A61B 6/4429;
A61C 19/04; G03B 42/04; G03B 42/025;
G03B 42/042
See application file for complete search history.

| | | | | | | |
|--------------|------|---------|-------------|-------|-------------|---------|
| 7,033,075 | B2 * | 4/2006 | Landis | | G03B 42/042 | 378/170 |
| 7,661,880 | B2 * | 2/2010 | Calderwood | | G03B 42/042 | 378/170 |
| 7,695,191 | B1 * | 4/2010 | Buchanan | | A61B 6/14 | 378/170 |
| 8,333,507 | B2 * | 12/2012 | Schmulenson | | A61B 6/4435 | 378/170 |
| D710,501 | S * | 8/2014 | Hayman | | D24/161 | |
| 8,876,375 | B2 * | 11/2014 | Laude | | G03B 42/042 | 378/170 |
| D723,169 | S * | 2/2015 | Ciesielka | | D24/161 | |
| D751,206 | S * | 3/2016 | Ratnow | | D24/161 | |
| 9,314,215 | B2 * | 4/2016 | Abramovich | | A61B 6/4435 | |
| 2002/0176539 | A1 * | 11/2002 | Da Rold | | A61B 6/145 | 378/167 |
| 2004/0096040 | A1 * | 5/2004 | Kilcher | | A61B 6/145 | 378/189 |

(Continued)

Primary Examiner — Mark A Goodwin

(74) *Attorney, Agent, or Firm* — Talus Law Group LLC

(57) **CLAIM**

The ornamental design for the detector holder coupler ring, as shown and described.

DESCRIPTION

FIG. 1 is a perspective view of the detector holder coupler ring showing the new design;
 FIG. 2 is a front elevation view thereof;
 FIG. 3 is a rear elevation view thereof;
 FIG. 4 is a right side elevation view thereof;
 FIG. 5 is a left side elevation view thereof;
 FIG. 6 is a top view thereof;
 FIG. 7 is a bottom view thereof;
 FIG. 8 is a perspective bottom view thereof; and,
 FIG. 9 is a perspective environmental view thereof.
 The dashed lines refer to environment and form no part of the claimed design.

1 Claim, 7 Drawing Sheets

(56) **References Cited**

U.S. PATENT DOCUMENTS

| | | | | | | |
|-----------|------|---------|----------|-------|-------------|---------|
| 4,251,732 | A * | 2/1981 | Fried | | A61B 6/4435 | 378/170 |
| 4,484,342 | A * | 11/1984 | Allison | | G03B 42/042 | 378/205 |
| 5,625,666 | A * | 4/1997 | Willis | | G03B 42/042 | 378/170 |
| D406,892 | S * | 3/1999 | Warren | | D24/176 | |
| 6,033,111 | A * | 3/2000 | Winters | | G03B 42/042 | 378/170 |
| 6,190,042 | B1 * | 2/2001 | Dove | | A61B 6/4435 | 378/170 |
| 6,343,875 | B1 * | 2/2002 | Eppinger | | A61B 6/4435 | 378/170 |

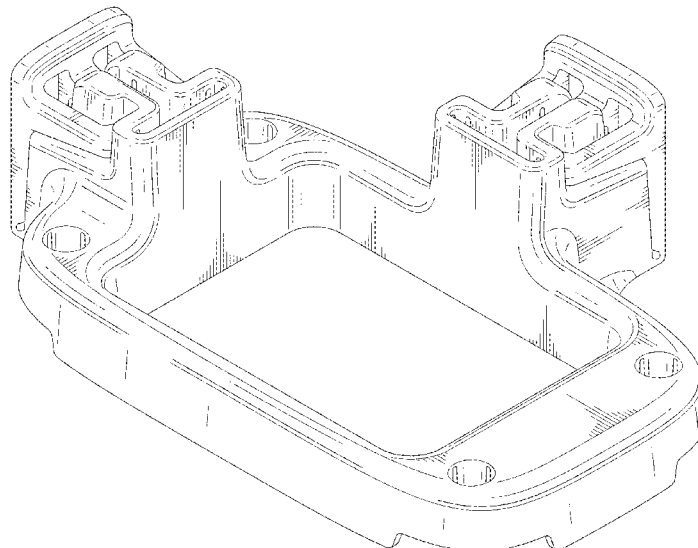

(56)

References Cited

U.S. PATENT DOCUMENTS

| | | | | |
|--------------|-----|--------|-------------------|------------------------|
| 2005/0013412 | A1* | 1/2005 | Calderwood | G03B 42/042 378/170 |
| 2007/0041506 | A1* | 2/2007 | Bottino | G03B 42/042 378/170 |
| 2007/0121789 | A1* | 5/2007 | Steck | A61B 6/145 378/168 |
| 2008/0095321 | A1* | 4/2008 | Calderwood | A61B 6/4423 378/170 |
| 2010/0027756 | A1* | 2/2010 | Hof | G03B 42/042 378/170 |
| 2011/0051900 | A1* | 3/2011 | Steward, Jr. | A61B 6/4435 378/170 |
| 2011/0164733 | A1* | 7/2011 | Steward, Jr. | G03B 42/042 378/170 |
| 2013/0071809 | A1* | 3/2013 | Kirkpatrick | A61B 6/145 433/29 |
| 2014/0056415 | A1* | 2/2014 | Abramovich | G03B 42/042 378/170 |
| 2015/0230764 | A1* | 8/2015 | Charnegie | A61B 6/4435 378/145 |
| 2020/0155093 | A1* | 5/2020 | Calderwood | A61B 1/24 |
| 2021/0290188 | A1* | 9/2021 | Spartiotis | G03B 42/042 |

* cited by examiner

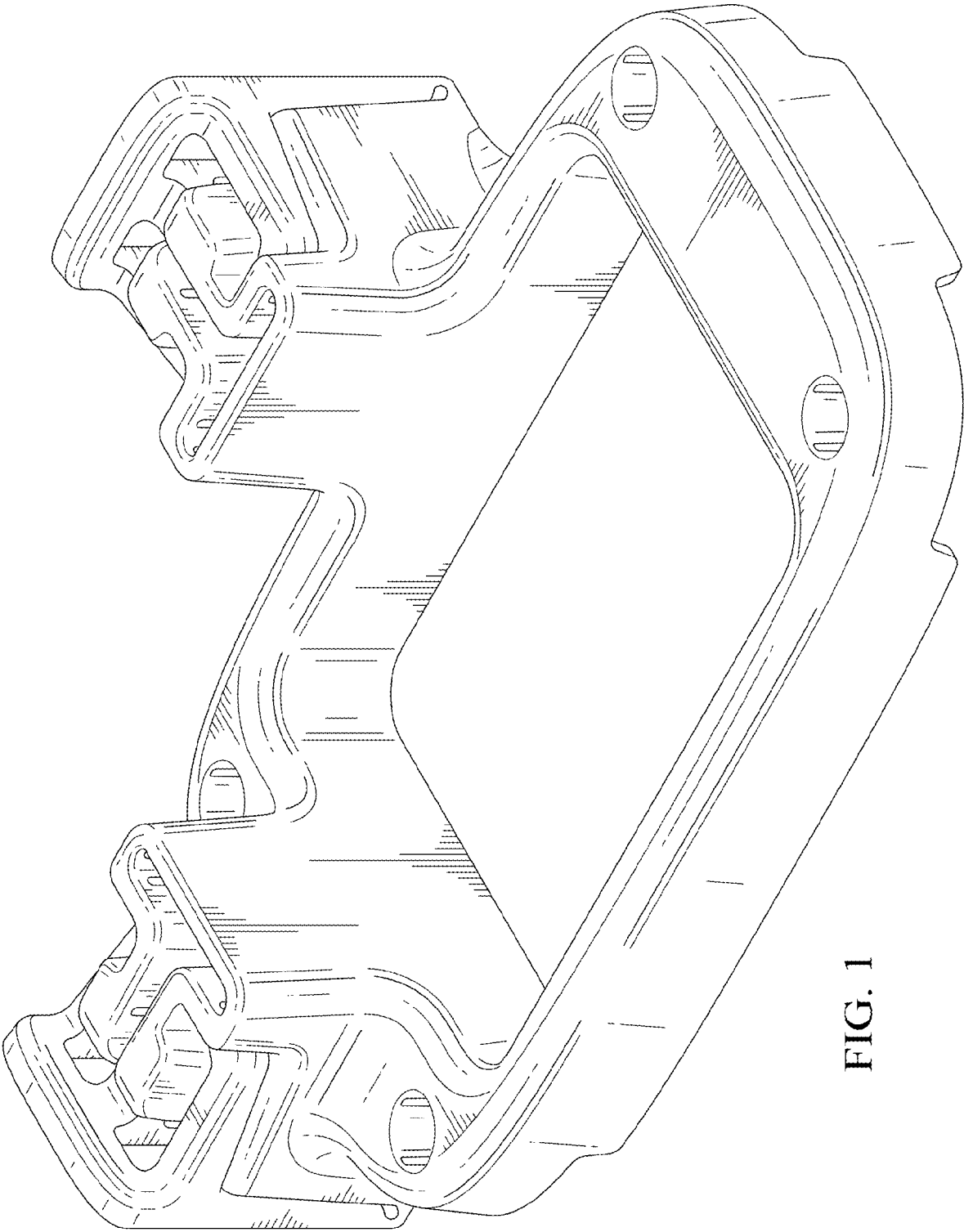

FIG. 1

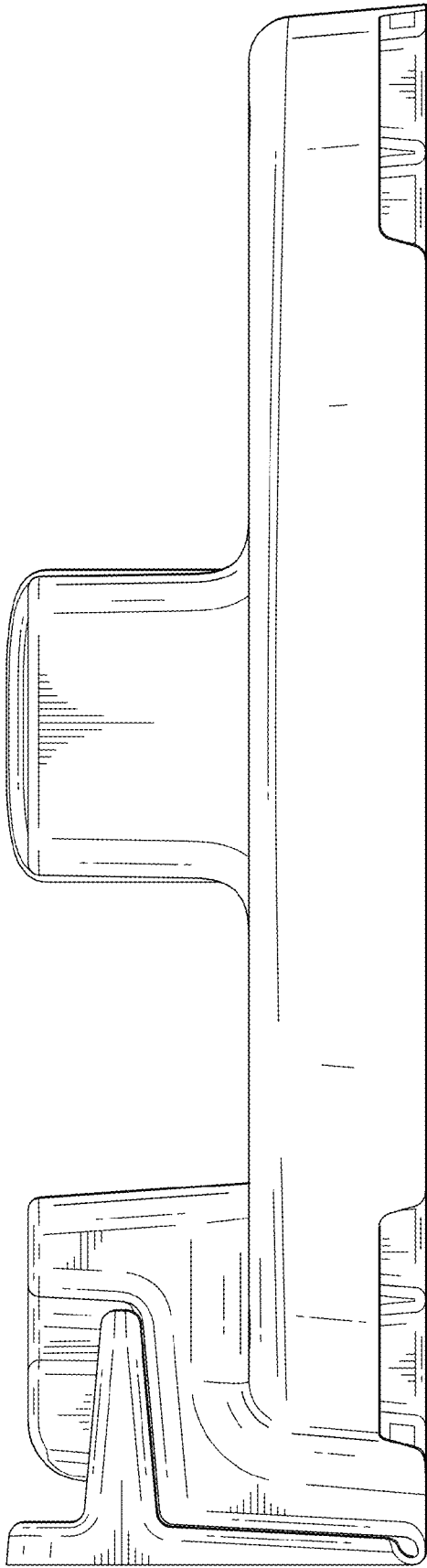

FIG. 2

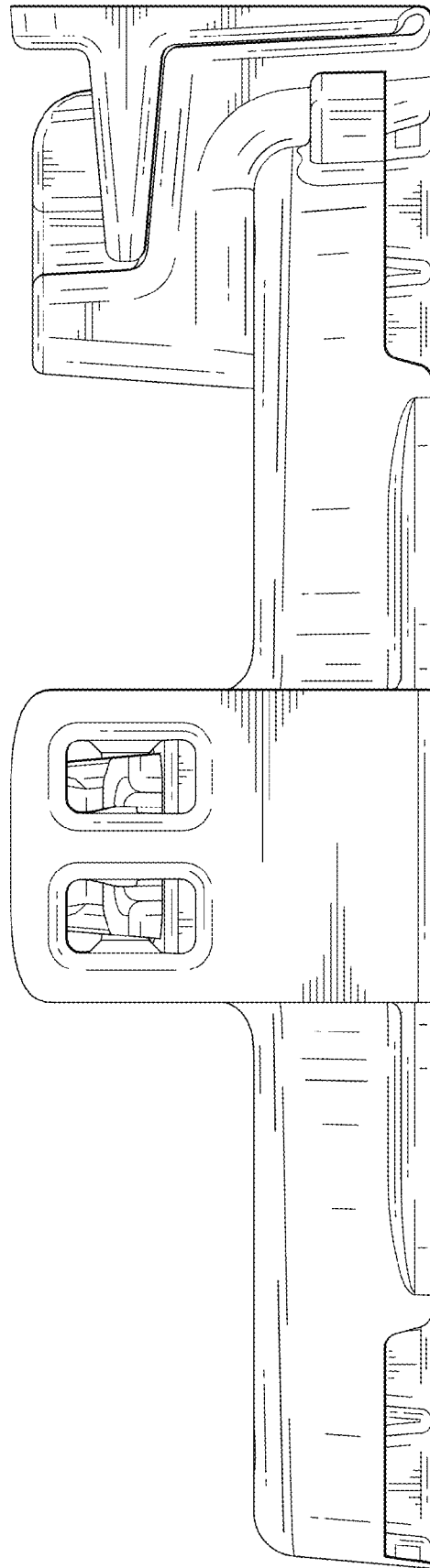

FIG. 3

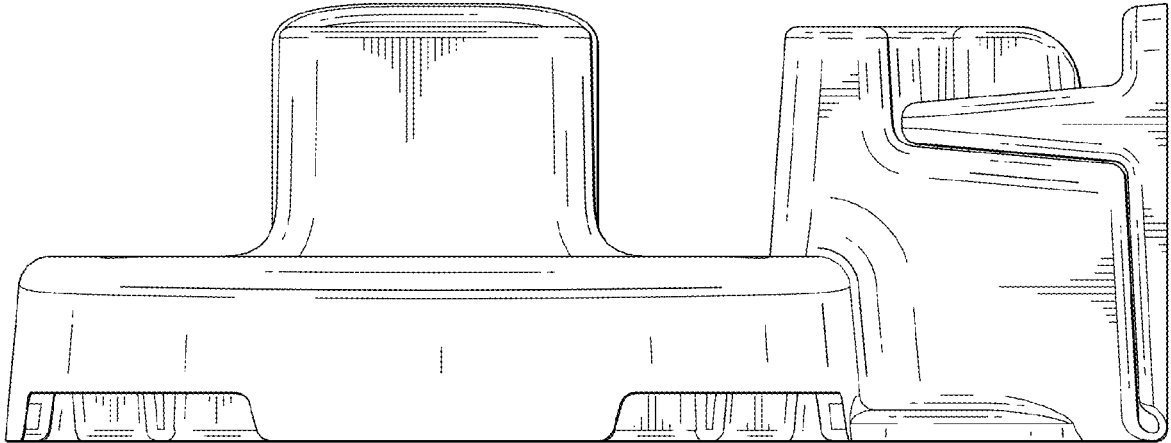

FIG. 4

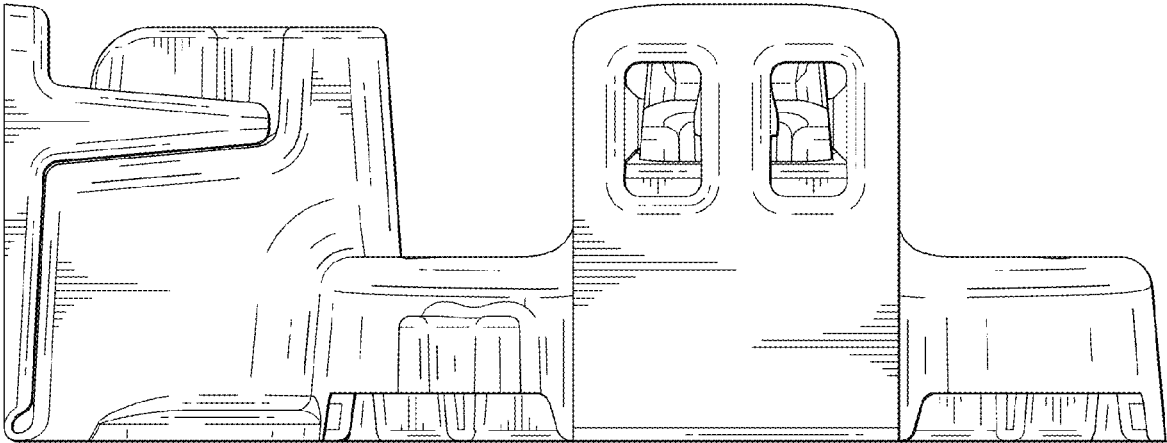

FIG. 5

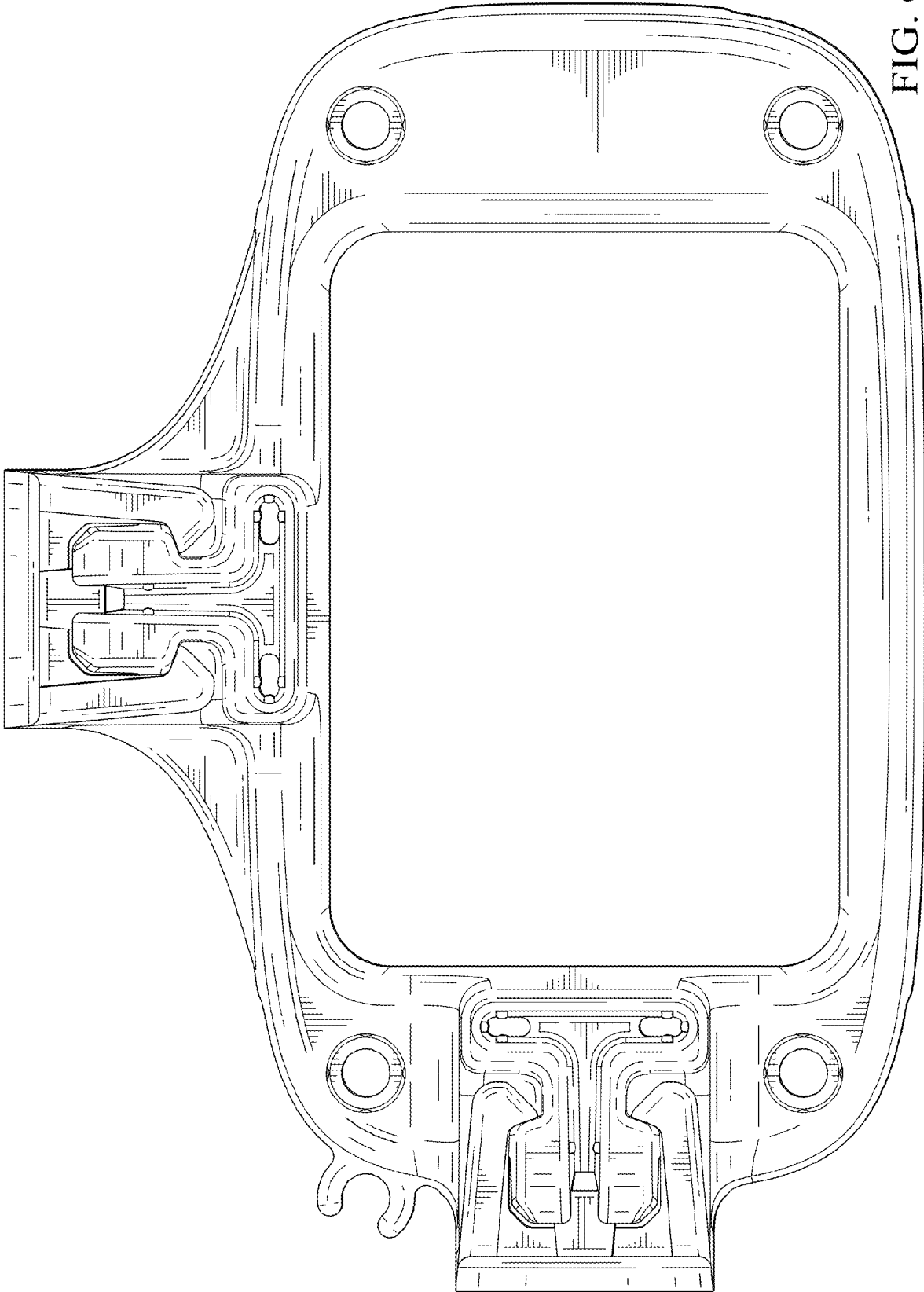

FIG. 6

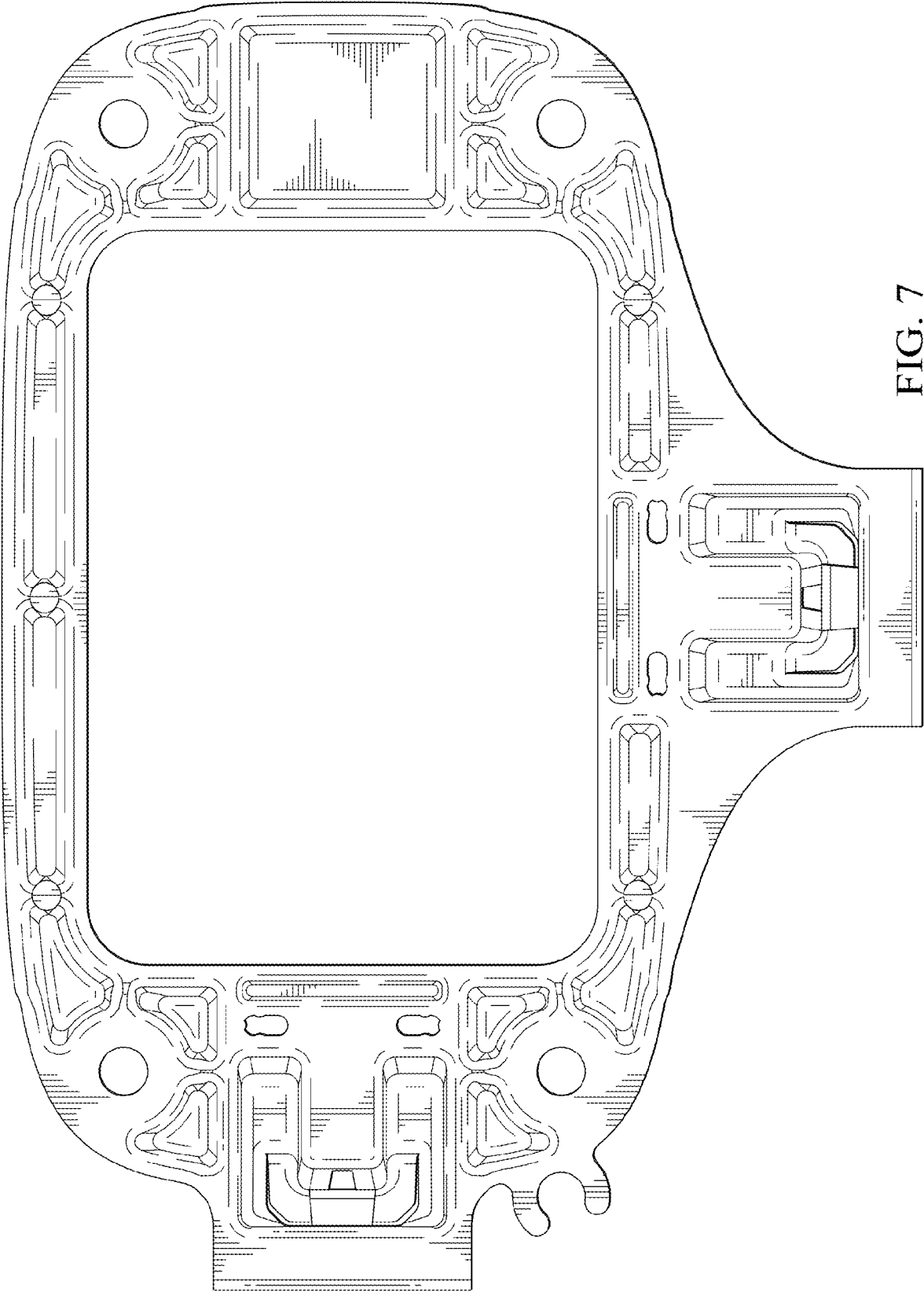

FIG. 7

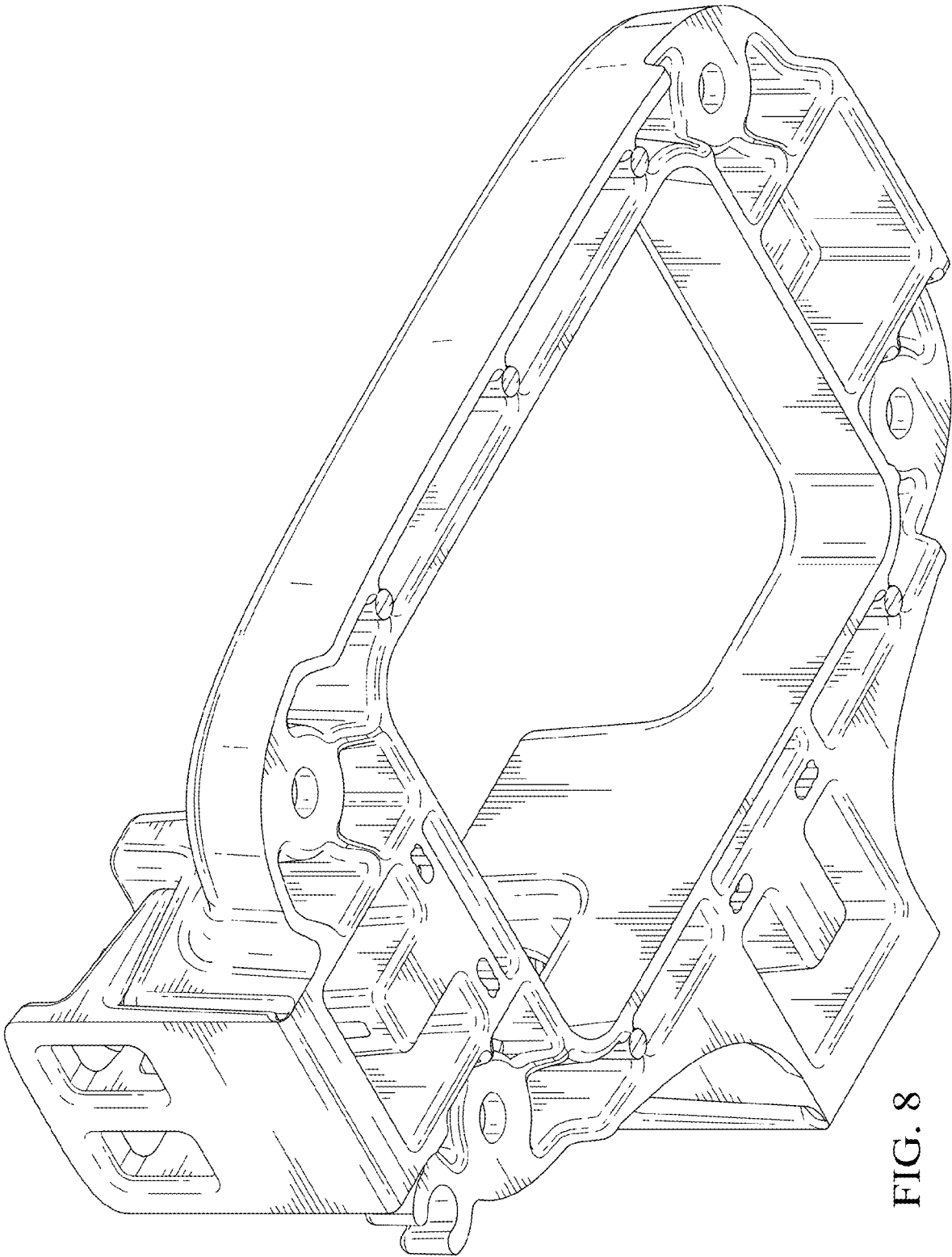

FIG. 8

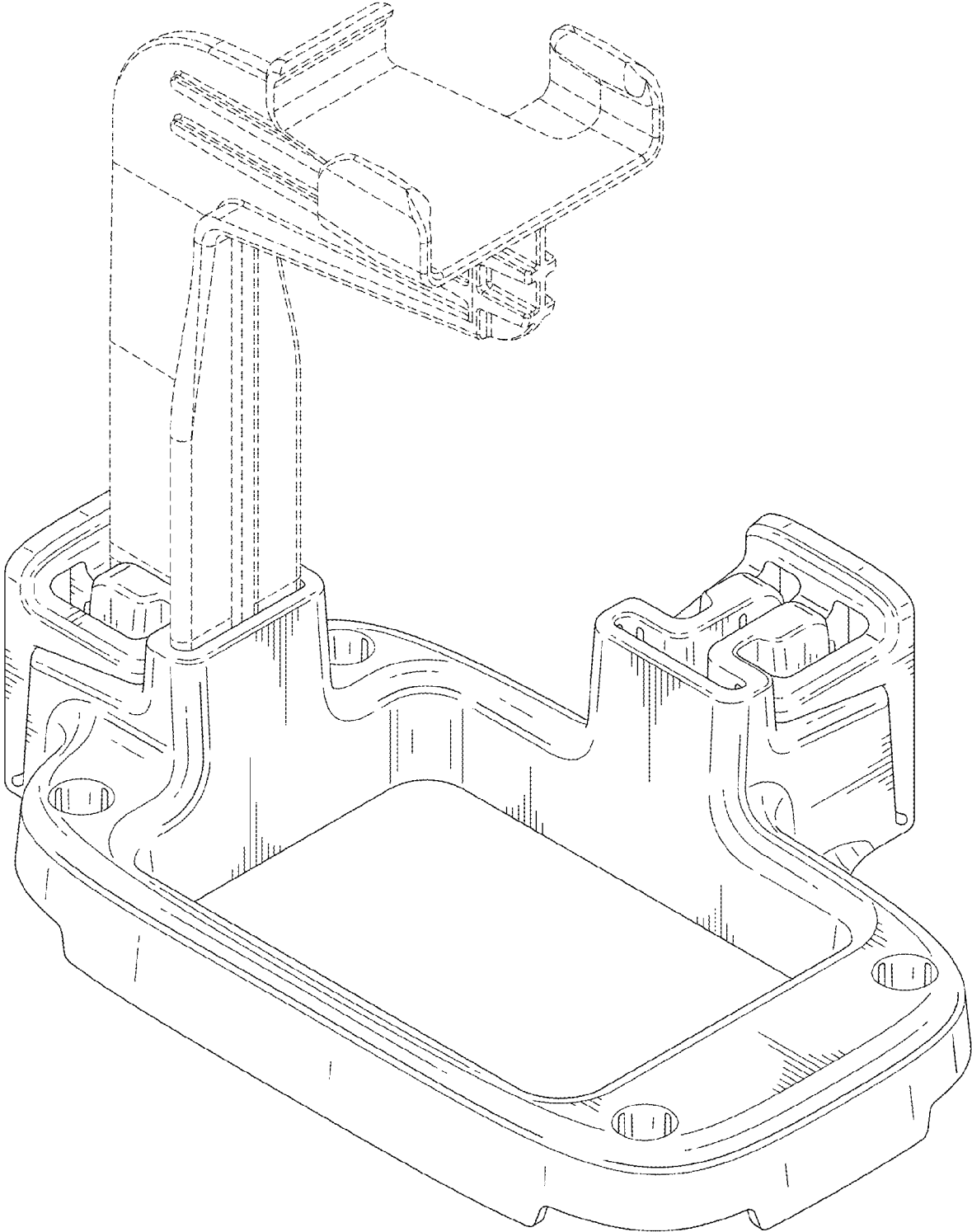

FIG. 9