



- (51) **International Patent Classification:**
G02B 7/02 (2006.01) G06K 7/10 (2006.01)
G02B 26/12 (2006.01)
- (21) **International Application Number:** PCT/IT2013/000221
- (22) **International Filing Date:** 6 August 2013 (06.08.2013)
- (25) **Filing Language:** Italian
- (26) **Publication Language:** English
- (71) **Applicant:** DATALOGIC IP TECH S.R.L. [IT/IT]; Via San Vitalino, 13, I-40012 Calderara di Reno (Bologna) (IT).
- (72) **Inventor:** CIABATTONI, Stefano; Via Salvador Allende, 1, I-40064 Ozzano dell'Emilia (Bologna) (IT).
- (74) **Agent:** CASTIGLIA, Paolo; Porta, Checcacci & Associati S.p.A., Via Trebbia, 20, I-20135 Milano (IT).
- (81) **Designated States** (unless otherwise indicated, for every kind of national protection available): AE, AG, AL, AM, AO, AT, AU, AZ, BA, BB, BG, BH, BN, BR, BW, BY,

BZ, CA, CH, CL, CN, CO, CR, CU, CZ, DE, DK, DM, DO, DZ, EC, EE, EG, ES, FI, GB, GD, GE, GH, GM, GT, HN, HR, HU, ID, IL, IN, IS, JP, KE, KG, KN, KP, KR, KZ, LA, LC, LK, LR, LS, LT, LU, LY, MA, MD, ME, MG, MK, MN, MW, MX, MY, MZ, NA, NG, NI, NO, NZ, OM, PA, PE, PG, PH, PL, PT, QA, RO, RS, RU, RW, SA, SC, SD, SE, SG, SK, SL, SM, ST, SV, SY, TH, TJ, TM, TN, TR, TT, TZ, UA, UG, US, UZ, VC, VN, ZA, ZM, ZW.

- (84) **Designated States** (unless otherwise indicated, for every kind of regional protection available): ARIPO (BW, GH, GM, KE, LR, LS, MW, MZ, NA, RW, SD, SL, SZ, TZ, UG, ZM, ZW), Eurasian (AM, AZ, BY, KG, KZ, RU, TJ, TM), European (AL, AT, BE, BG, CH, CY, CZ, DE, DK, EE, ES, FI, FR, GB, GR, HR, HU, IE, IS, IT, LT, LU, LV, MC, MK, MT, NL, NO, PL, PT, RO, RS, SE, SI, SK, SM, TR), OAPI (BF, BJ, CF, CG, CI, CM, GA, GN, GQ, GW, KM, ML, MR, NE, SN, TD, TG).

Published: — with international search report (Art. 21(3))

(54) **Title:** READING DEVICE FOR READING CODED INFORMATION AND METHOD FOR FOCUSING SUCH A READING DEVICE

FIG.1

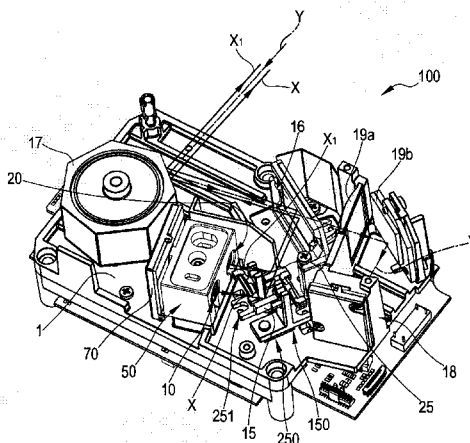

(57) **Abstract:** Device (100) for reading coded information, comprising a first optical group (10) including a first light source and first focusing means in optical alignment with said light source along an optical axis (X), and at least one further optical group including a further light source and further focusing means in optical alignment with the further light source along an optical axis (X1) parallel to the optical axis (X). The first optical group (10) and the further optical group (20) are housed in a single one-piece block (50) obtained through a single mechanical processing that, preferably, is a machine tool processing. The number of components of the reading device is thus reduced and the calibration operations necessary to achieve the desired optical alignment between light sources and with the respective focusing means are simplified and automated. Consequently, the costs of material and qualified workers are reduced, as is the time needed to calibrate the reading device.



**Reading device for reading coded information and method
for focusing such a reading device**

DESCRIPTION

The present invention relates, in a first aspect thereof,
5 to a reading device for reading coded information.

The invention also relates to a method for focusing the
aforementioned reading device.

Throughout the following description and the following
claims, the expression: "reading coded information" is used
10 to indicate the acquisition of information related to an
object (for example distance, volume, overall dimensions,
or object identification data) for example through the
acquisition and processing of a light signal diffused by
the same object. In this case the term: "coded information"
15 is used to indicate the whole identification data contained
in an optical code.

The term: "optical code" is used to indicate any graphical
representation having the function of storing a coded
information. A particular example of optical code consists
20 of the linear or two-dimensional codes, wherein the
information is coded through suitable combinations of
elements having a predetermined shape, for example squared,
rectangular or hexagonal, of dark colour (usually black)
separated by clear elements (spaces, usually white), such
25 as barcodes, stacked codes and two-dimensional codes in
general, colour codes, etc. The term "optical code" further
comprises, more generally, also other graphical patterns
with information coding function, including clear printed
characters (letters, numbers, etc.) and special patterns
30 (such as stamps, logos, signatures, fingerprints, etc.).
The term "optical code" also comprises graphical
representations which are detectable not only in the field
of visible light but also in the range of wavelengths
comprised between infrared and ultraviolet.

- 2 -

For the sake of simplicity of description, hereafter explicit reference will be made to optical code readers (commonly called: scanners).

5 Devices for reading optical codes comprising a single light source that is typically a laser (monolaser, fixed focus or autofocus reading devices) are known as well as devices for reading optical codes comprising many light sources (multilaser or multifocus reading devices).

10 Multilaser reading devices essentially comprise two or more sources of respective laser light beams, a scanning device for scanning the aforementioned laser light beams on the optical code to be read, a photo-receiver device adapted to collect the light diffused by the illuminated code and to generate an electrical signal proportional to the intensity
15 of the collected light and a device for processing the aforementioned electrical signal adapted to provide, in conclusion, the sequence of the decoded characters of the optical code read.

20 Typically, between each light source and the scanning device there are one or more deflecting mirrors of the laser light emitted by the light source.

Downstream of each of the light sources and upstream of the aforementioned deflecting mirrors a respective focusing device for focusing the light beam is provided. Generally,
25 each focusing device comprises at least one convergent lens and possibly a diaphragm. The focusing device is adapted to focus the light beam passing through it at a desired distance, such a distance corresponding to that at which the optical code to be read is arranged. Optimal focusing
30 is achieved by adjusting the axial position of the focusing device with respect to the light source.

Some examples of multilaser reading devices are described and shown in EP 0926615, which represents the closest prior art that the Applicant is aware of.

- 3 -

The Applicant observed that the multilaser reading devices of the prior art require suitable calibration operations in order to obtain the desired optical parallel arrangement between the various light beams emitted by the different
5 light sources, as well as the desired optical alignment between each light source and the respective focusing device and between each focusing device and the respective deflecting mirrors.

In practice, the aforementioned calibration operations
10 require extremely fine adjustment of the position of each light source with respect to the other light sources, as well as of the position of each focusing device with respect to a respective light source and of each deflecting mirror with respect to a respective focusing device (and
15 therefore to a respective light source).

In the multilaser reading devices known to the Applicant all of the components that need to be adjusted are mounted on a supporting board through suitable adjustment screws and the calibration/adjustment operations described above
20 are carried out by a specialised worker by acting manually on the aforementioned adjustment screws.

The Applicant observed that, due to the large number of components that need to be adjusted and to the need to proceed exclusively by manual interventions, in the
25 multilaser reading devices that are currently known the calibration operations are extremely long and complex.

The Applicant thus considered the problem of simplifying as much as possible the calibration operations in multilaser reading devices.

30 For this purpose, the Applicant has thought to simplify as much as possible the mechanical structure of the multilaser reading devices. More specifically, the Applicant has designed a mechanical structure that allows both the number of components subject to adjustment and the manual

calibration interventions on such components to be reduced to the minimum, in such a way achieving a reduction in material costs and, in particular, in the costs of qualified manpower, and in the time taken for calibration.

- 5 The present invention therefore relates, in a first aspect thereof, to a reading device for reading coded information, comprising:
- a first optical group including a first light source and first focusing means in optical alignment with said first
 - 10 light source along a first optical axis;
 - at least one further optical group including a further light source and further focusing means in optical alignment with said further light source along a further optical axis parallel to said first optical axis;
 - 15 characterised in that said first optical group and at least one further optical group are housed in respective seats formed in a single one-piece block obtained through a single mechanical processing.

Throughout the present description and in the subsequent

20 claims, the expression "optical alignment" is used to indicate a condition of substantial coincidence between the optical axes of two distinct optical components (light source and focusing means, in the case discussed above).

Throughout the present description and in the subsequent

25 claims, the expression "single mechanical processing" is used to indicate any mechanical processing in which, after the semi-worked piece from which the final piece will be obtained has been positioned in the machine by a worker, there are no subsequent steps of handling and repositioning

30 of the semi-worked piece by the worker.

Advantageously, the fact that all of the optical groups of the reading device of the present invention are housed in a single one-piece block makes it possible to simplify the calibration operations of the reading device and to reduce

35 the specialised workforce costs, at the same time ensuring

high precision of positioning of the various light sources and of the respective focusing devices. In fact, the precision of positioning is in this case only relied on the mechanical manufacturing processing of the one-piece block.

5 Such a mechanical processing does not include any manual repositioning of the piece being worked, thus avoiding making possible repositioning errors. Furthermore, there is no need to use adjustment screws and/or specific housing blocks for each of the optical groups of the reading

10 device, thus achieving a reduction in the number of mechanical components of the reading device and, therefore, of the material costs.

Basically, the correct optical parallel arrangement between the light beams of the different light sources and the

15 correct optical alignment between light source and respective focusing device (and, therefore, more generally, the adjustment of the position of the aforementioned first and further optical groups) is obtained in a totally automatic way at the design and manufacturing stage of the

20 one-piece block, without the need for manual interventions by specialised workers on adjustment screws or the like.

In general, the aforementioned mechanical processing can be any mechanical processing capable of ensuring the desired precision of processing.

25 In a preferred embodiment of the present invention, such a one-piece block is made through a machine tool processing.

Preferably, such a machine tool is a conventional multi-axis numerical control machine tool. This type of machine, as known, is capable of reaching even very tight

30 dimensional tolerances through totally automatic processing.

In alternative embodiments of the present invention, the aforementioned one-piece block is made through an ultraprecise moulding processing.

- 6 -

Preferably, the one-piece block is a solid block, i.e. it does not have any area in which the material has been removed for weight reduction purposes. The Applicant has thus pursued a design choice that goes away from the
5 conventional ones typically aimed at making the pieces lighter.

The design choice of the Applicant also allows the structural rigidity of the block to be maximised, with a consequent advantage in terms of precision of mutual
10 positioning of the single components in the one-piece block.

The design choice of the Applicant also makes it possible to ensure a high mass for dissipating the heat generated by the light sources, with a consequent increase in the useful
15 lift of such sources.

Advantageously, the provision of a large mass for dissipating heat allows, being the service life equal, the use of even very high power light sources.

Preferably, the one-piece block has a dissipating mass of
20 about 10 cm^3 for each of the light sources being used. In particular, the Applicant has found that, in the case in which two lasers are used, each of which having a maximum power equal to 50 mW, and the maximum operating temperature of the reading device being 50°C , in order to obtain the
25 desired large dissipating mass it is advantageous to use a one-piece block made of aluminium having a volume of at least 10 cm^3 for each laser (i.e. in the specific case discussed herein an overall volume of at least 20 cm^3), with a tolerance of $\pm 10\%$.

30 In preferred embodiments of the present invention, the one-piece block comprises:
- a first seat for housing said first light source and said first focusing means, said first seat being formed coaxially to a first longitudinal axis;

- 7 -

- at least one further seat for housing said further light source and said further focusing means, said at least one further seat being formed coaxially to a further longitudinal axis parallel to said first longitudinal axis; 5 wherein said first longitudinal axis and further longitudinal axis coincide with said first optical axis and further optical axis, respectively.

Advantageously, the desired mutual positioning between the various light sources and of the focusing means with 10 respect to the light sources is thus achieved by forming in the one-piece block suitable housing seats having respective parallel axes. This is obtained in an extremely simple manner and with high degrees of precision thanks to the automation and precision of the machine tool processing 15 through which the one-piece block is manufactured.

Preferably, the one-piece block comprises a base surface for mounting in said reading device and said first longitudinal axis and further longitudinal axis are at different distances from said base surface. In this way, it 20 is obtained not only the desired optical parallel arrangement between the light beams emitted by the various light sources housed in the one-piece block, but it is also obtained an advantageous propagation of the aforementioned light beams at different heights, which facilitates the 25 mutual arrangement of the deflecting mirrors provided downstream of the light sources to direct the respective light beams towards the optical code to be read. Indeed, the different heights of propagation of the light beams impose a different height of positioning of the respective 30 deflecting mirrors, thus avoiding a deflecting mirror which deviates one light beam obstructing the optical path of a different light beam (otherwise it would be necessary to use a very expensive deflecting mirror since it would have a reflective portion to allows a light beam to be deviated and a transmitting portion to allow another light beam to 35 pass).

- 8 -

In preferred embodiments of the reading device of the present invention, said first light source and further light source are coupled by interference with said first seat and further seat, respectively. Such a type of coupling ensures high precision and stability of positioning. Moreover, in this way the mutual contact surface between the one-piece block and the light sources is increased, with consequent advantageous effects in terms of dissipation of the heat generated by the light sources, which can in this case even be of very high power. However, it is possible to foresee couplings which are different from the interference coupling, provided that they are capable of ensuring good thermal conductivity.

Preferably, the first focusing means are housed in a first barrel and said further focusing means are housed in a further barrel, said first barrel and further barrel being sized so as to be slidably coupled in said first seat and further seat, respectively. Advantageously, such a sliding coupling allows the adjustment of the distance of the barrel from the respective light source and, therefore, the focusing of the light beam emitted by said light source. The aforementioned adjustment is carried out without losing the correct optical alignment between light source and barrel.

Preferably, each barrel comprises at least one convergent lens (more preferably two lenses, of which at least one is convergent) and a diaphragm.

In the preferred embodiments of the reading device of the present invention, said first barrel and further barrel are fixed in position in said first seat and further seat, respectively, through an adhesive substance, preferably a glue that polymerises when irradiated by ultraviolet light (UV glue).

Preferably, each of said first barrel and further barrel comprises a respective annular groove. Advantageously, such

a groove is adapted to be engaged, in the calibration operation of the reading device, by an arm of an adjustment apparatus for adjusting the distance of the barrel from the respective light source. Through such an arm, the barrel is
5 moved axially with respect to the respective light source until the light beam emitted by said light source is focused at the desired distance. Throughout the present description, the aforementioned adjustment apparatus will also be indicated with the expression "focusing equipment".

10 Thanks to the annular shape thereof, forming the groove is extremely easy if, as in the preferred embodiments of the present invention, the groove is made through a machine tool processing.

Preferably, the annular groove has a substantially
15 trapezoidal-shaped orthogonal cross section. Such a shape allows self-centring of the respective arm of the focusing equipment, minimising any clearances.

In the preferred embodiments of the present invention, the one-piece block comprises a first through groove open in
20 said first seat and a further through groove open in said further seat. Such through grooves are intended to house the arms of the focusing equipment in the calibration operations of the reading device. Advantageously, the arms and the aforementioned through grooves are sized so as to
25 avoid any mutual contact, so as not to generate friction.

In order to obtain high precision of positioning of the barrels inside the respective housing seats during the calibration operations of the reading device, the dimensions of said first through groove and further through
30 groove are preferably selected so as to obtain the best compromise between the need to have high structural rigidity of the focusing equipment (which would require massive sizing of the arms of the focusing equipment) and that of maintaining a sufficient strength and stability of
35 the one-piece block (which would require a width of the

- 10 -

grooves that is as small as possible). In this respect, in the preferred embodiments of the present invention, the width of the groove does not exceed 50% of the diameter of the barrel.

5 Preferably, said first through groove and further through groove are parallel to one another and comprise respective planes of symmetry containing said first longitudinal axis and said further longitudinal axis, respectively. In this way, the movement of each of the barrels by the respective
10 arm of the focusing equipment takes place maintaining the desired optical alignment with the respective light source.

In the preferred embodiments of the present invention, the one-piece block further comprises a first through opening open in said first seat and a further through opening open
15 in said further seat. Such openings allow the introduction of the adhesive substance inside the one-piece block to fix the barrels in position.

Preferably, said first through opening and further through opening have a substantially elliptical shape. In
20 particular, they define respective slots. Advantageously, the elongated shape of the aforementioned through openings promotes the distribution of the adhesive substance on a sufficiently large surface, so as to achieve a sufficiently stable fixing in position of the barrels.

25 Preferably, said first through opening and further through opening are sized so as not to extend above the annular groove of the respective barrel irrespective of the axial position of said first barrel and further barrel, thus even when the barrels are at the most recessed position. In this
30 way, the adhesive substance introduced into the one-piece block through each through opening is prevented from running away along the annular grooves of the barrels and contaminating the surface of the various components of the reading device and/or of the focusing equipment. Moreover,
35 the adhesive substance that has possibly run along the

- 11 -

annular grooves, is prevented from going under the barrels and being hidden by the barrels themselves, thus without being polymerised and without contributing to fixing the barrels in position in the respective seats.

5 Preferably, each of said first through groove and further through groove is open at said base surface and each of said first through opening and further through opening is open at a top surface of said one-piece block. In this way, during the calibration operations of the reading device,
10 the focusing equipment can operate from below of the one-piece block, whereas the dosing of the adhesive substance can take place from above the one-piece block, thus without interfering with the focusing operation. Moreover, the adhesive substance in this way is distributed at constant
15 thickness along the entire surface extension of the groove, which ensures homogeneous behaviour of the adhesive substance during the subsequent hardening or solidification step.

Preferably, said first barrel and further barrel are made
20 of brass, whereas the one-piece block is preferably made of metallic material, more preferably aluminium.

In preferred embodiments of the present invention, at least the seats for housing the barrel are made of aluminium. There is thus a brass-aluminium coupling, which
25 advantageously has a low friction coefficient.

The one-piece block can comprise, on the surface of each of the aforementioned seats, a surface coating made of a material having a low friction coefficient, preferably a material based on polytetrafluoroethylene (PTFE), also
30 known commercially as Teflon®. In particular, it is possible to foresee a hard anodization surface treatment and an impregnation by Teflon of the seat, as they are commonly and universally defined in the field.

In general, the Applicant has found that it is advantageous

- 12 -

to implement some provisions in order to achieve a condition of ideal compromise between the opposite needs to have, on the one hand, a low friction coefficient between barrel and respective seat during the focusing operation of the reading device, so as to obtain very small displacement resolutions and, on the other hand, a sufficiently high friction coefficient to counteract possible movements of the barrel generated by the adhesive substance during the hardening or solidification step, so as to avoid undesired displacements of the focus.

According to the Applicant, it is possible to achieve the aforementioned condition of ideal compromise by obtaining a suitable balancing of the forces to which the barrel is subjected during the focusing and fixing in position operations as a consequence of the hardening or solidification of the adhesive substance. The Applicant has, indeed, found that, during the aforementioned operations, the barrel is subjected to forces acting in opposite directions: a first force, acting along a first direction, is generated by the thrust exerted by the adhesive substance that solidifies, and a second force, acting along an opposite direction to the first one, which depends both on the friction force at the interface between barrel and respective seat, which in turn depends on the friction coefficient typical of the materials from which the barrel and respective seat are made and on the dimensional tolerances of the coupling between barrel and respective seat, and on the force by which the arm of the focusing device holds the barrel in position in the respective seat during the hardening or solidification of the adhesive substance (such a force being adjustable by the worker).

The Applicant has found that, since the friction coefficient at the interface between barrel and respective seat is known once the materials from which the barrel and the respective seat are to be made have been selected,

- 13 -

since the dimensional tolerances of the coupling between barrel and respective seat are known, and since the force by which the arm of the focusing device holds the barrel in position in the respective seat can be adjusted by the worker, the aforementioned second force can be quantitatively determined. Consequently, in order to obtain the desired balance of the forces, once the position and the size of the through openings have been suitably selected, it is sufficient to select an adhesive substance whose coefficient of expansion in the solidification step exactly counterbalances such a second force. Alternatively, once an adhesive substance has been selected that ensures a suitable hold after gluing, and once the materials from which the barrel and the respective seat are to be made have been selected, being known the dimensional tolerances of the coupling between barrel and respective seat, it is possible to determine the pressure by which the arm of the focusing equipment must hold the barrel in position in the respective seat until the desired balance is obtained.

Preferably, an adhesive substance is used having a tensile strength equal to at least 3000 psi and a viscosity at 25°C comprised between 6000 and 8000 cps, (measured through a rotor or spindle #3, at 10 RPM, with a Brookfield viscometer RVT). The Applicant has found that in this way it is possible to ensure the maximum hold against detachment and the best distribution of the adhesive substance inside the through openings.

Preferably, the reading device of the present invention comprises an electronic board associated with the one-piece block at said first light source and further light source.

In the preferred embodiments of the present invention, the reading device further comprises:

- a first deflecting mirror in optical alignment with said first optical group;
- a further deflecting mirror in optical alignment with said further optical group;

- 14 -

- a first adjusting member for adjusting the angular position of said first deflecting mirror with respect to said first optical group;
- a further adjusting member for adjusting the angular position of said further deflecting mirror with respect to said further optical group.

In the present invention, "optical alignment" of the deflecting mirror means a particular positioning such that the point of incidence of the optical axis of the light beam striking the mirror does not vary as the positioning angle of the mirror on a horizontal and/or vertical plane varies; this occurs when the aforementioned point of incidence is on the rotation axis of the mirror.

Preferably, said first adjustment member and further adjustment member are identical. In this way, an advantageous production saving is achieved.

Preferably, said first adjustment member and further adjustment member are adjustably positioned without acting on adjustment screws.

Preferably, each of said first adjustment member and further adjustment member comprises a first left/right adjustment bracket and a second up/down adjustment bracket.

Preferably, each left/right adjustment bracket is pivoted in said reading device at a first pivoting axis that, preferably, intersects a respective optical axis of said first optical axis and further optical axis. In this way it is possible to ensure that as the positioning angle of the left/right adjustment bracket (and therefore of the mirror associated with said bracket) varies, the point of incidence of the respective optical axis on said mirror always stays the same. The desired optical alignment is thus maintained.

Preferably, each left/right adjustment bracket comprises a supporting post for supporting the respective deflecting

- 15 -

mirror and a base flange, said base flange comprising a first coupling portion for coupling with said reading device and, preferably, on the opposite side to said first coupling portion with respect to said supporting post, a
5 second coupling portion for coupling with a tool for adjusting the angular position of said left/right adjustment bracket, said first pivoting axis being preferably defined in said first coupling portion.

10 Preferably, each left/right adjustment bracket is fixed in position inside said reading device through an adhesive substance, more preferably a UV glue of the same type used to fix the barrels in position in the respective seats formed in the one-piece block.

15 Preferably, said first deflecting mirror and further deflecting mirror are fixedly associated with the respective up/down adjustment bracket and each up/down adjustment bracket is rotatably mounted on the respective left/right adjustment bracket at a rotation axis that intersects a respective optical axis of said first optical
20 axis and further optical axis. In this way it is possible to ensure that as the positioning angle of the up/down adjustment bracket (and therefore of the mirror associated with said bracket) varies, the point of incidence of the respective optical axis on said mirror always stays the
25 same. The desired optical alignment is thus maintained.

30 Preferably, each up/down adjustment bracket comprises a central coupling portion for coupling with a respective left/right adjustment bracket, a first end portion for coupling with the respective deflecting mirror and, preferably, on the opposite side to said first end portion with respect to said central coupling portion, a second end portion, wherein said deflecting mirror is fixedly associated with said up/down adjustment bracket at said first end portion, said second end portion preferably
35 comprising engagement means for engaging a tool for adjusting the angular position of said up/down adjustment

bracket.

In the preferred embodiments of the present invention, each left/right adjustment bracket comprises at least two seats for coupling with the respective up/down adjustment
5 bracket, said two seats being arranged at different heights. The left/right adjustment bracket can thus support deflecting mirrors at different heights. This allows the same type of left/right adjustment bracket to be used for all of the optical groups provided in the reading device.

10 Preferably, each up/down adjustment bracket is fixed to a respective left/right adjustment bracket through an adhesive substance, more preferably a UV glue of the same type used to fix the barrels in position in the respective seats formed in the one-piece block.

15 Preferably, the central portion of the up/down adjustment bracket comprises a substantially flat top portion. Such a top portion defines an ideal surface for depositing the adhesive substance, thus promoting a greater uniformity of distribution of the adhesive substance.

20 Preferably, the one-piece block and said first adjustment member and further adjustment member are mounted on a single supporting board.

In a second aspect thereof, the invention relates to a method for focusing a reading device for reading coded
25 information, said reading device comprising at least one optical group including a light source and focusing means in optical alignment with said light source along an optical axis and housed in a respective seat, wherein between said focusing means and said seat a predetermined
30 friction force acts and wherein said seat has a through opening for the introduction of an adhesive substance adapted to fix said focusing means in said seat in a focus position, said method comprising the steps of:

- selecting an adhesive substance having a predetermined

- 17 -

coefficient of expansion during solidification;

- during the solidification of said adhesive substance, holding said focusing means in said focus position by applying a holding force that, together with said friction
5 force, counter-balances the force to which said focusing means are subjected because of the solidification of said adhesive substance.

The Applicant has found that, by carrying out the aforementioned method, it is possible to achieve an optimal
10 focusing of the reading device. Indeed, on the one hand very small displacement resolutions are ensured and, on the other hand, undesired movements of the focus are prevented, as discussed above in greater detail.

Preferably, the reading device used in the aforementioned
15 method comprises, individually or in combination, all of the features described above with reference to the reading device of the present invention.

For example, preferably, said adhesive substance is a glue having a tensile strength equal to at least 3000 psi and a
20 viscosity at 25°C comprised between 6000 and 8000 cps.

Preferably, said focusing means are housed in a barrel sized so as to be slidably coupled in said seat.

Preferably, said barrel is made of brass.

Preferably, said seat is formed in a one-piece block
25 obtained through a single mechanical processing, more preferably through a machine tool processing.

Preferably, said one-piece block is made of metallic material, preferably aluminium.

Preferably, said one-piece block comprises, at least at
30 said seat, a surface coating having a low friction coefficient.

Further characteristics and advantages of the device of the

- 18 -

present invention will become clearer from the following detailed description of a preferred embodiment thereof, made purely as a non-limiting example with reference to the attached drawings. In such drawings:

- 5 - figure 1 is a schematic perspective view of a functional inner module of a reading device in accordance with the present invention;
- figure 2 is an enlarged schematic perspective view of a component of the module of figure 1;
- 10 - figure 3 is a schematic perspective view of the component of figure 2 from a different observation point;
- figure 4 is a schematic perspective view of the component of figure 2 from a yet different observation point;
- 15 - figure 5 is a schematic perspective view of a one-piece block of the component of figures 2-4;
- figure 6 is a schematic perspective view of an optical emission group housed in the one-piece block of figure 5;
- figure 7 is a schematic perspective view of an optical
20 deflecting group arranged in the module of figure 1;
- figure 8 is a schematic perspective view of a first adjustment bracket of the optical deflecting group of figure 7;
- figure 9 is a schematic perspective view of a second
25 adjustment bracket of the optical deflecting group of figure 7;
- figure 10 shows, in a cross section of the component of figure 2 taken at a plane P, the forces acting on such a component during the focusing operations.
- 30 In figure 1, reference numeral 100 indicates a reading device for reading coded information in accordance with the present invention. In particular, just the functional inner module of the reading device 100 is shown. The casing inside which the aforementioned module is housed is thus
35 not shown.

The reading device 100 is, in particular, a laser scanner

used for example in systems for transporting and sorting objects of various kinds (for example parcels, suitcases, bags, etc..) for the acquisition of data identifying the objects and for the consequent intelligent sorting of the objects themselves.

In these systems, the objects are placed on a conveyor belt that is in movement with respect to the laser scanner (which is typically mounted in a fixed position) and are sorted based on the reading of an optical code printed on a label associated with each object. Such reading is carried out through the aforementioned laser scanner.

The functional module shown in figure 1 comprises a supporting board 1 for supporting the various opto-electronic and mechanical components of the reading device 100.

In particular, on the board 1 two identical optical groups 10, 20 are mounted, shown in greater detail in figure 6.

Each of the optical groups 10, 20 comprises a respective light source 11, 21 (preferably a conventional semiconductor laser diode) and respective focusing means 12, 22 of the light beam emitted by the respective light source 11, 21.

Each light source 11, 21 emits a respective laser light beam having a respective optical axis, indicated in the figures respectively with X and X1.

As shown in figures 1, 2 and 4, the optical axes X and X1 are substantially horizontal and substantially parallel. They maintain such a condition of substantially parallel optical arrangement along the respective optical emission paths defined between the respective light source 11, 21 and the illuminated object.

The focusing means 12, 22 are arranged in optical alignment with the respective light source 11, 21.

- 20 -

Each of the focusing means 12, 22 comprises in particular a barrel 120, 220 (figures 4, 6 and 10) inside which at least one convergent lens 13, 23 (preferably a barrel comprising two or more lenses) and a diaphragm 14, 24, shown in figure 5 2 and 10, are fixedly mounted.

As shown in figures 4, 6 and 10, each barrel 120, 220 comprises an annular groove 121, 221 close to the emission face of the laser light beam that passes through it. Such an annular groove 121, 221 preferably has a substantially 10 trapezoidal-shaped or conical orthogonal cross section.

With reference to figure 1, a respective deflecting group 150, 250 (shown in greater detail in figures 7-9) is also mounted on the optical board 1 downstream of each of the optical groups 10, 20 with reference to the optical path of 15 the light beams emitted by the light sources 11, 21. Each deflecting group 150, 250 comprises a respective mirror 15, 25 adapted to deflect the light beam emitted by a respective light source 11, 21.

A single deflecting mirror 16 is also mounted on the 20 optical board 1 downstream of the deflecting groups 150, 250, and a conventional scanning device 17 is arranged downstream of said mirror 16.

In the particular embodiment described herein, the light beams emitted by the light sources 11, 21 reach the objects 25 on which the optical codes to be read are placed through respective optical paths (identified by the respective optical axes X, X1) each defined by a broken line comprising four sections inclined to one another. A first section is defined between each light source 11, 21 and the 30 respective deflecting mirror 15, 25. A second section is defined between each deflecting mirror 15, 25 and the deflecting mirror 16. A third section is defined between the deflecting mirror 16 and the scanning device 17 and a fourth and last section is defined between the scanning 35 device 17 and the illuminated object.

- 21 -

The functional module shown in figure 1 also comprises a photoreceiver device 18 adapted to collect the light diffused by the illuminated optical code and to generate an electrical signal proportional to the intensity of the collected light. Such an electrical signal, once it has been suitably processed, provides the sequence of the decoded characters of the optical code read.

A receiving lens 19a is arranged upstream of the photoreceiver device 18, with reference to the optical receiving path of the light diffused by each illuminated optical code, and a deflecting mirror 19b is arranged between the receiving lens 19a and the photoreceiver device 18.

In the particular embodiment described herein, the light beam diffused by the illuminated object reaches the photoreceiver device 18 through an optical path (identified in figure 1 by the optical axis Y indicated by a dotted line) defined by a broken line comprising three sections inclined to one another. A first section is defined between the illuminated object and the scanning device 17. A second section is defined between the scanning device 17 and the deflecting mirror 19b and a third and last section is defined between the deflecting mirror 19b and the photoreceiver device 18.

As shown in figure 2, the optical groups 10, 20 are housed inside suitable seats 10a, 20a having a substantially cylindrical shape and formed in a one-piece block 50, also shown in figures 3-5 and described below.

In the specific embodiment shown, the one-piece block 50 is made of metallic material, preferably aluminium, and is obtained through processing with a conventional multi-axis numerical control machine tool. It has a massive structure, i.e. without openings or cavities specifically provided for weight reduction purposes. Such a massive structure advantageously ensures a high structural rigidity and a

- 22 -

high mass for dissipating the heat generated by the light sources 11, 21.

In a specific embodiment, two laser light sources 11, 12 are used, each of which has a maximum power equal to 50 mW, and a maximum operating temperature of the reading device 100 of 50°C is foreseen. In this case, the one-piece block of aluminium has an overall volume equal to at least 20 cm³, with a tolerance of ±10%, so as to offer the light sources with a large mass for dissipating the heat generated thereby.

The seats 10a, 20a are formed through chip removal processing on the same machine tool on which the one-piece block 50 is manufactured.

The processing of the metallic block 50 thus includes just the positioning of the piece to be worked on the machine tool and the controlled movement of the chip removal tool around the aforementioned piece to define the final shape of the one-piece block 50. Since there are no manual displacement and/or repositioning operations of the piece, the precision with which the one-piece block 50 is manufactured is solely correlated to the precision of the machine tool used to manufacture it.

With reference to figures 2-5, the one-piece block 50 comprises a top surface 51 on which a hole 51a is formed. Such a hole 51a is intended to allow the one-piece block 50 to be fixed on the supporting board 1.

The one-piece block 50 also comprises a base surface 52 (figure 4) comprising a plurality of holes. In the embodiment shown herein there are three holes, all indicated with 52a. The central hole is intended to allow the one-piece block 50 to be fixed on the supporting board 1, whereas the other two holes are intended to allow the one-piece block 50 to be centred on a focusing equipment described below, by coupling with corresponding centring

- 23 -

pins suitable provided on the latter.

The one-piece block 50 comprises opposite side surfaces 53a, 53b, a front surface 54 (figure 2, 4 and 5) and a rear surface 55 (figure 3).

- 5 The one-piece block 50 also comprises, at each seat 10a, 20a, a through groove 10a', 20a' extending from the base surface 52 of the one-piece block 50 up to the seat 10a, 20a.

- 10 The through grooves 10a' and 20a' are parallel to one another and extend astride of respective planes of symmetry on which the respective optical axis X, X1 lies.

- As shown in figure 3, the light sources 11, 21 are coupled, preferably by interference, with special holes 11a, 21a formed on the rear surface 55 of the one-piece block 50
15 coaxially to the seats 10a, 20a. The longitudinal axis of each hole 11a, 21a in this way substantially coincides with the longitudinal axis of the respective seat 10a, 20a and with the optical axis X, X1 of the light beam emitted by the respective light source 11, 21.

- 20 Again with reference to figures 2-5, the longitudinal axes of the seats 10a, 20a housing the optical groups 10, 20 are substantially parallel to one another.

- The seats 10a, 20a are formed in the one-piece block 50 at different heights with respect to the base surface 52.
25 Consequently, the optical axes X and X1 of the light sources 11, 21 are in a desired condition of parallel optical arrangement and of vertical offsetting. The precision of the parallel optical arrangement thus achieved is high, deriving solely from the precision of the machine
30 tool processing, which as known is high.

The barrels 120, 220 have a diameter that is slightly smaller than the diameter of the seats 10a, 20a, so as to slidably couple with the seats 10a, 20a. Such a possibility

- 24 -

of sliding is exploited in the calibration step of the reading device 100 to focus the laser light beams emitted by the light sources 11, 21 to the desired distance.

5 Once focusing has been achieved, the barrels 120, 220 are fixed in position in the respective seats 10a, 20a through an adhesive substance. Such an adhesive substance is introduced into the seats 10a, 20a through respective through holes 60a, 60b formed on the top surface 51 of the one-piece block 50.

10 Each through opening 60a, 60b has a substantially elliptical shape, so as to define a slot.

As shown in figure 10, the position and the longitudinal size of each through opening 60a, 60b is preferably such that the through opening 60a, 60b does not go above the annular groove 121, 221 of the respective barrel 120, 220. 15 In other words, a length S of non-juxtaposition between through opening 60a, 60b and annular groove 121, 221 of the respective barrel 120, 220 is provided in the position of most recessed position of the barrel 120, 200.

20 Preferably, the width of each through groove 60a, 60b does not exceed 50% of the diameter of the respective barrel 120, 220.

In general, indicating the diameter and the length of the barrels 120, 220 with D and L, respectively, the dimensions 25 of each through opening 60a, 60b can be expressed by the following relationships: length equal to $(0.43-0.45)L$ and width equal to $(0.27-0.28)D$.

In a preferred embodiment, the barrels 120, 220 have a diameter D equal to 11 mm and a length L equal to 16 mm; 30 therefore, each through opening 60a, 60b has a width equal to about 3 mm and a length equal to about 7 mm.

Preferably, each through opening 60a, 60b has a depth of about 2.5-3 mm.

- 25 -

These dimensions ensure a condition of ideal compromise between having a sufficient surface to ensure the stability/hold of the glue and avoiding the through opening 60a, 60b at least partially juxtaposing the annular groove
5 121, 221.

The adhesive substance used is preferably a UV glue that, at room temperature, has a sufficiently dense liquid state and that, after having been illuminated by a suitable lamp (not shown), solidifies, thus permanently fixing the
10 barrels 120, 220 in position in the respective seats 10a, 20a.

In particular a lamp is used at each through opening 60a, 60b, in order to obtain a substantially simultaneous solidification in both seats 10a, 20a.

15 The UV glue preferably has a sufficient density to allow the formation of droplets during deposition and to ensure that it remains in the position in which it was deposited to then be able to solidify in such a position. The UV glue is preferably dosed automatically through the through
20 openings 60a, 60b by a suitable dispensing device that is not shown.

Preferably, a glue is used having a tensile strength equal to at least 3000 psi and a viscosity at 25°C comprised between 6000 and 8000 cps, (measured through a rotor or
25 spindle #3, at 10 RPM, with a Brookfield viscometer RVT), like for example OPTOCAST AC-3724L of Electronic Materials Incorporated of Breckenridge, CO, USA.

The sliding of the barrels 120, 220 in the respective seats 10a, 20a is carried out by acting on the respective annular
30 grooves 121, 221 through a suitable micrometric automatic focusing equipment, not shown.

In particular, in the calibration operation of the reading device 100, the aforementioned focusing equipment is arranged below the one-piece block 50 and comprises two

- 26 -

arms, each of which crosses a respective through groove 10a', 20a' until it engages a respective annular groove 121, 221.

5 The focusing equipment comprises an actuator for
controlling the movement of the aforementioned arms inside
the through grooves 10a' 20a' (and therefore the movement
of the barrels 120, 220 inside the seats 10a, 20a). The
focusing equipment is also combined with a camera that
10 films the footprint of the light beam emitted by each light
source 11, 21 at the focusing distance and commands the
actuator in order to move the arms (and therefore the
barrels 120, 220) until focus is achieved.

The aforementioned arms have engagement ends which engage
with the annular grooves 121, 221. The engagement ends have
15 a shape matching the shape of the cross section of the
annular grooves 121, 221. The sizing of the aforementioned
arms is also such as to prevent them from coming into
contact with the opposite surfaces of the through grooves
10a', 20a' during their movement.

20 With reference to figure 10, the focusing of the reading
device 100 comprises, once the barrels 120, 220 have
reached the focus position, the introduction in the one-
piece block 50, through the through openings 60a, 60b, of
the adhesive substance, so as to fix the barrels 120, 220
25 in position in the respective seats 10a, 20a. The fixing in
position of the barrels 120, 220 takes place because of the
solidification of the adhesive substance. During such
solidification the barrels are held in position by the
aforementioned arms with a force F_v that, added to the
30 friction force F_a at the interface between barrels 120, 220
and respective seats 10a, 20a, generates an overall force
equal and opposite to the force F_c exerted by the adhesive
substance in the solidification step, thus obtaining an
advantageous balancing of the various forces.

35 The barrels 120, 220 are preferably made of brass.

- 27 -

The inner surface of the seats 10a, 20a can be coated or treated so as to provide a low friction coefficient. In this case, a double surface treatment is foreseen, consisting of a hard oxidation and an impregnation by
5 Teflon® (trade name of polytetrafluoroethylene, PTFE), as it is commonly and universally defined in the field.

With reference to figure 1, an electronic board 70 is associated with the rear surface 55 of the one-piece block 50 and with the rheophores 111, 211 of the light sources
10 11, 21 to command and control the operation of the latter.

As stated earlier and as shown in figure 1, the two deflecting groups 150, 250 are mounted downstream of the one-piece block 50, with reference to the optical paths defined by the optical axes X, X1 coming out from the one-
15 piece block 50. Each deflecting group 150, 250 supports a respective deflecting mirror 15, 25 so that it is in optical alignment with a respective optical axis X, X1.

The two deflecting groups 150, 250 are identical. One of them is shown in detail in figures 7-9.

20 Each deflecting group 150, 250 comprises a first bracket 160 for adjusting the angular position of the mirror 15, 25 on a horizontal plane (hereafter "left/right adjustment bracket" or "vertical bracket"). Such a bracket 160 is mounted on the supporting board 1 and is shown in figures 7
25 and 8.

Each deflecting group 150, 250 also comprises a second bracket 170 for adjusting the angular position of the mirror 15, 25 on a vertical plane (hereafter "up/down adjustment bracket" or "horizontal bracket"). Such a
30 bracket 170 is rotatably coupled with the vertical bracket 160 and is shown in figures 7 and 9.

The deflecting mirror 15, 25 is fixedly mounted (preferably through a suitable adhesive substance) on the horizontal bracket 170.

- 28 -

The vertical bracket 160 has a base flange 161 pivoted to the supporting board 1 at a substantially vertical pivoting axis V. The pivoting axis V intersects a respective optical axis X, X1 on the respective mirror 15, 25.

- 5 An post 162 extends substantially perpendicular to the base flange 161 at an intermediate portion thereof.

The post 162 defines two opposite coupling portions in the base flange 161. On a first coupling portion 163a the pivoting axis V is defined, whereas on the opposite
10 coupling portion 163b a seat 164 is defined for a tool (not shown) used to carry out the left/right adjustment.

In a preferred embodiment of the present invention, suitable for ensuring a resolution of the left/right adjustment of 0.02° , the length of the base flange 161 is
15 equal to about 19 mm.

A tab 166 projects from a central portion of a side surface of the vertical bracket 160.

On the post 162 two seats 165, 265 are formed for coupling with the bracket 170. Such seats 165, 265 are formed at a
20 different height and both have opposite cylindrical surface portions. When the bracket 160 is used to support the deflecting mirror 15 arranged at the optical axis X, the bracket 170 is coupled with the seat 165 (as shown in figure 7). Otherwise, when the bracket 160 is used to
25 support the deflecting mirror 25 arranged at the optical axis X1, the bracket 170 is coupled with the seat 265 (as can be glimpsed in figure 1).

The horizontal bracket 170 comprises a central portion 171 for coupling with one of the aforementioned seats 165, 265.

30 The central portion 171 comprises opposite cylindrical surface portions adapted to allow the rotation of the horizontal bracket 170 with respect to the vertical bracket 160 in order to obtain the up/down adjustment. In figure 9

- 29 -

it is only possible to see one of said cylindrical surface portions, indicated with 171a.

The central portion 171 also comprises a substantially flat top portion 171b. Such a top portion 171b is adapted to
5 face upwards when the horizontal bracket 170 is mounted in the reading device 100. The aforementioned top portion, in addition to promote better uniformity of distribution of the adhesive substance on the up/down adjustment bracket, allows the insertion of the horizontal bracket in the
10 proper seat 165, 265 through an opening 162a formed on the top of the vertical bracket 160, such an opening being defined by opposite flat surfaces.

The rotation of the horizontal bracket 170 with respect to the vertical bracket 160 takes place around a substantially
15 horizontal rotation axis O. The rotation axis O intersects a respective optical axis X, X1 on a respective mirror 15, 25.

The horizontal bracket 170 comprises two end portions arranged on opposite sides with respect to the central
20 portion 171. On a first end portion 172a the mirror 15, 25 is mounted, whereas the opposite end portion 172b is shaped so as to define an engagement arm for engaging a tool used to carry out the up/down adjustment.

In a preferred embodiment of the present invention,
25 suitable for ensuring a resolution of the up/down adjustment of 0.07° , the length of the horizontal bracket 170 is equal to about 8 mm.

Once the desired angular position of the vertical bracket 160 and of the horizontal bracket 170 (and therefore,
30 overall, the angular position of the deflecting mirrors 15, 25 with respect to the horizontal and vertical planes) has been achieved, the aforementioned brackets are fixed in position (the vertical bracket 160 with respect to the supporting board 1 and the horizontal bracket 170 with

- 30 -

respect to the vertical bracket 160) through an adhesive substance that, preferably, is a UV glue of the same type used to fix the barrels 120, 220 in position in the respective seats 10a, 20a formed in the one-piece block 50.

5 As shown in figure 1, the vertical bracket 160 of the deflecting group 150 (i.e. the vertical bracket 160 that supports the mirror 15) is mounted in opposite position with respect to the vertical bracket 160 of the deflecting group 250 (i.e. the vertical bracket 160 that supports the
10 mirror 25). In this case, the tabs 166 of the two vertical brackets 160 are side-by-side, so that the dosing of the adhesive substance in the area engaged by both of the tabs 166 allows both of the vertical brackets 160 to be blocked in position. The seats 164 of the two vertical brackets
15 160, on the other hand, are oriented opposite to the respective posts 162. Similarly, the end portions 172b of the two horizontal brackets 170 are oriented opposite to the respective posts 162. In this way it is possible to mount the two mirrors 15, 25 at the minimum distance apart
20 from one other (with clear advantages in terms of compactness of the reading device 100) without risking any mechanical interference in the left/right and up/down adjustment operations.

From the above description, it can be understood that the
25 reading device 100 of the present invention makes it possible, through a relatively simple mechanical structure, to reduce to the minimum the number of components subject to adjustment and the manual calibration interventions, achieving the foreseen purposes identified above. It can
30 also be understood that the focusing method described above allows an optimum focusing of the reading device.

Of course, a man skilled in the art can make further changes and modifications in order to meet specific and contingent application requirements, these changes and
35 modifications in any case falling within the scope of protection defined by the following claims.

CLAIMS

1. Reading device (100) for reading coded information, comprising:
- 5 - a first optical group (10) including a first light source (11) and first focusing means (12) in optical alignment with said first light source (11) along an optical axis (X);
 - 10 - at least one further optical group (20) including a further light source (21) and further focusing means (22) in optical alignment with said further light source (21) along a further optical axis (X1) parallel to said first optical axis (X);
- characterised in that said first optical group (10) and at least one further optical group (20) are housed in
- 15 respective seats (10a, 20a) formed in a single one-piece block obtained through a single mechanical processing.
2. Reading device (100) according to claim 1, wherein said mechanical processing is a machine tool processing.
3. Reading device (100) according to claim 1 or 2, wherein
- 20 said first optical group (10) and further optical group (20) are adjustably positioned without acting on adjustment screws.
4. Reading device (100) according to any one of the preceding claims, wherein said one-piece block (50) does
- 25 not have any area in which the material has been removed for weight reduction purposes.
5. Reading device (100) according to any one of the preceding claims, wherein said one-piece block (50) comprises:
- 30 - a first seat (10a) for housing said first light source (11) and said first focusing means (12), said first seat (10a) being formed coaxially to a first longitudinal axis;
 - at least one further seat (20a) for housing said further light source (21) and said further focusing means (22),

- 32 -

- said at least one further seat (20a) being formed coaxially to a further longitudinal axis parallel to said first longitudinal axis;
- wherein said first longitudinal axis and further longitudinal axis coincide with said first optical axis (X) and further optical axis (X1), respectively.
- 5
6. Reading device (100) according to claim 5, wherein said one-piece block (50) comprises a base surface (52) for mounting in said reading device (100) and wherein said
- 10 first longitudinal axis and further longitudinal axis are at different distances from said base surface (52).
7. Reading device (100) according to claim 5 or 6, wherein said first light source (11) and further light source (21) are coupled by interference with said first seat (10a) and
- 15 further seat (20a), respectively.
8. Reading device (100) according to any one of claims 5 to 7, wherein said first focusing means (12) are housed in a first barrel (120) and said further focusing means (22) are housed in a further barrel (220), said first barrel (120) and further barrel (220) being sized so as to be slidably
- 20 coupled in said first seat (10a) and further seat (20a), respectively.
9. Reading device (100) according to claim 8, wherein said first barrel (120) and further barrel (220) are made of
- 25 brass.
10. Reading device (100) according to claim 8 or 9, wherein said first barrel (120) and further barrel (220) are fixed in position in said first seat (10a) and further seat (20a), respectively, through an adhesive substance.
- 30 11. Reading device (100) according to claim 10, wherein said adhesive substance is a glue having a tensile strength equal to at least 3000 psi and a viscosity at 25°C comprised between 6000 and 8000 cps.

12. Reading device (100) according to any one of claims 8 to 11, wherein each of said first barrel (120) and further barrel (220) comprises a respective annular groove (121, 221).
- 5 13. Reading device (100) according to claim 12, wherein said annular groove (121, 221) has a substantially trapezoidal-shaped orthogonal cross section.
14. Reading device (100) according to any one of claims 5 to 13, wherein said one-piece block (50) comprises a first
10 through groove (10a') open in said first seat (10a) and a further through groove (20a') open in said further seat (20a).
15. Reading device (100) according to claim 14, wherein said first through groove (10a') and further through groove
15 (20a') are parallel to one another and comprise respective planes of symmetry containing said first longitudinal axis and said further longitudinal axis, respectively.
16. Reading device (100) according to any one of claims 5 to 15, wherein said one-piece block (50) comprises a first
20 through opening (60a) open in said first seat (10a) and a further through opening (60b) open in said further seat (20a).
17. Reading device (100) according to claim 16, wherein said first through opening (60a) and further through
25 opening (60b) have a substantially elliptical shape.
18. Reading device (100) according to claim 16 or 17 when depending on claim 12 or 13, wherein said first through opening (60a) and further through opening (60b) do not extend up to above the annular groove (121, 221)
30 irrespective of the axial position of said first barrel (120) and further barrel (220).
19. Reading device (100) according to any one of claims 16 to 18 and claim 14 or 15, when depending on claim 6,

- 34 -

wherein each of said first through groove (10a') and further through groove (20a') is open at said base surface (52) and each of said first through opening (60a) and further through opening (60b) is open at a top surface (51)
5 of said one-piece block (50).

20. Reading device (100) according to any one of the preceding claims, wherein said one-piece block (50) is made of metallic material, preferably aluminium.

21. Reading device (100) according to any one of the
10 preceding claims, wherein said one-piece block comprises, at least at said first seat (10a) and further seat (20a), a surface coating having a low friction coefficient.

22. Reading device (100) according to any one of the preceding claims, comprising an electronic board (70)
15 associated with said one-piece block (50) at said first light source (11) and further light source (21).

23. Reading device (100) according to any one of the preceding claims, further comprising:
20 - a first deflecting mirror (15) in optical alignment with said first optical group (10);
- a further deflecting mirror (25) in optical alignment with said further optical group (20);
- a first adjustment member for adjusting the angular position of said first deflecting mirror (15) with respect
25 to said first optical group (10);
- a further adjustment member for adjusting the angular position of said further deflecting mirror (25) with respect to said further optical group (20).

24. Reading device (100) according to claim 23, wherein
30 said first adjustment member and further adjustment member are identical.

25. Reading device (100) according to claim 23 or 24, wherein said first adjustment member and further adjustment member are adjustably positioned without acting on

adjustment screws.

26. Reading device (100) according to any one of claims 23 to 25, wherein each of said first adjustment member and further adjustment member comprises a first left/right
5 adjustment bracket (160) and a second up/down adjustment bracket (170).

27. Reading device (100) according to claim 26, wherein each left/right adjustment bracket (160) is pivoted in said reading device (100) at a first pivoting axis (V) that
10 intersects a respective optical axis (X, X1) of said first optical axis (X) and further optical axis (X1).

28. Reading device (100) according to claim 27, wherein each left/right adjustment bracket (160) comprises a supporting post (162) for supporting the respective
15 deflecting mirror (15, 25) and a base flange (161), said base flange (161) comprising a first coupling portion (163a) for coupling with said reading device (100) and, on the opposite side to said first coupling portion (163a) with respect to said supporting post (162), a second
20 coupling portion (163b) for coupling with a tool for adjusting the angular position of said left/right adjustment bracket (160), wherein said first pivoting axis (V) is defined in said first coupling portion (163a).

29. Reading device (100) according to any one of claims 26 to 28, wherein each left/right adjustment bracket (160) is
25 fixed in said reading device (100) through an adhesive substance.

30. Reading device (100) according to any one of claims 26 to 29, wherein said first deflecting mirror (15) and
30 further deflecting mirror (25) are fixedly associated with the respective up/down adjustment bracket (170) and wherein each up/down adjustment bracket (170) is rotatably mounted on the respective left/right adjustment bracket (160) at a rotation axis (O) that intersects a respective optical axis

- 36 -

(X, X1) of said first optical axis (X) and further optical axis (X1).

31. Reading device (100) according to any one of claims 26 to 30, wherein each up/down adjustment bracket (170) comprises a central coupling portion (171) for coupling with a respective left/right adjustment bracket (160), a first end portion (172a) for coupling with the respective deflecting mirror (15, 25) and, on the opposite side to said first end portion (172a) with respect to said central coupling portion (171), a second end portion (172b), wherein said deflecting mirror (15, 25) is fixedly associated with said up/down adjustment bracket (170) at said first end portion (172a) and wherein said second end portion (172b) comprises engagement means for engaging a tool for adjusting the angular position of said up/down adjustment bracket (170).

32. Reading device (100) according to claim 31, wherein said central portion (171) comprises a substantially flat top portion (171b).

33. Reading device (100) according to any one of claims 26 to 32, wherein each left/right adjustment bracket (160) comprises at least two seats (165, 265) for coupling with the respective up/down adjustment bracket (170), said two seats (165, 265) being arranged at different heights.

34. Reading device (100) according to any one of claims 26 to 33, wherein each up/down adjustment bracket (170) is fixed to a respective left/right adjustment bracket (160) through an adhesive substance.

35. Reading device (100) according to any one of claims 23 to 34, wherein said one-piece block (50) and said first adjustment member and further adjustment member are mounted on a single supporting board (1).

36. Method for focusing a reading device (100) for reading coded information, said reading device (100) comprising at

least one optical group (10, 20) including a light source (11, 21) and focusing means (12, 22) in optical alignment with said light source (11, 21) along an optical axis (X, X1) and housed in a respective seat (10a, 20a), wherein
5 between said focusing means (12, 22) and said seat (10a, 20a) a predetermined friction force (Fa) acts and wherein said seat (10a, 20a) has a through opening (60a, 60b) for the introduction of an adhesive substance adapted to fix said focusing means (12, 22) in said seat (10, 20a) in a
10 focus position, said method comprising the steps of:

- selecting an adhesive substance having a predetermined coefficient of expansion during solidification;
- during the solidification of said adhesive substance, holding said focusing means (12, 22) in said focus position
15 by applying a holding force (Fv) that, together with said friction force (Fa), counter-balances the force to which said focusing means (12, 22) are subjected because of the solidification of said adhesive substance.

37. Method according to claim 36, wherein said adhesive
20 substance is a glue having a tensile strength equal to at least 3000 psi and a viscosity at 25°C comprised between 6000 and 8000 cps.

38. Method according to claim 36 or 37, wherein said focusing means (12, 22) are housed in a barrel (120, 220)
25 sized so as to be slidably coupled in said seat (10a, 20a).

39. Method according to claim 38, wherein said barrel (120, 220) is made of brass.

40. Method according to any one of claims 36 to 39, wherein
30 said seat (10a, 20a) is formed in a one-piece block (50) obtained through a single mechanical processing.

41. Method according to claim 40, wherein said mechanical processing is a machine tool processing.

42. Method according to claim 40 or 41, wherein said one-

- 38 -

piece block (50) is made of metallic material, preferably aluminium.

43. Method according to any one of claims 40 to 42, wherein said one-piece block comprises, at least at said seat (10a,
5 20a), a surface coating having a low friction coefficient.

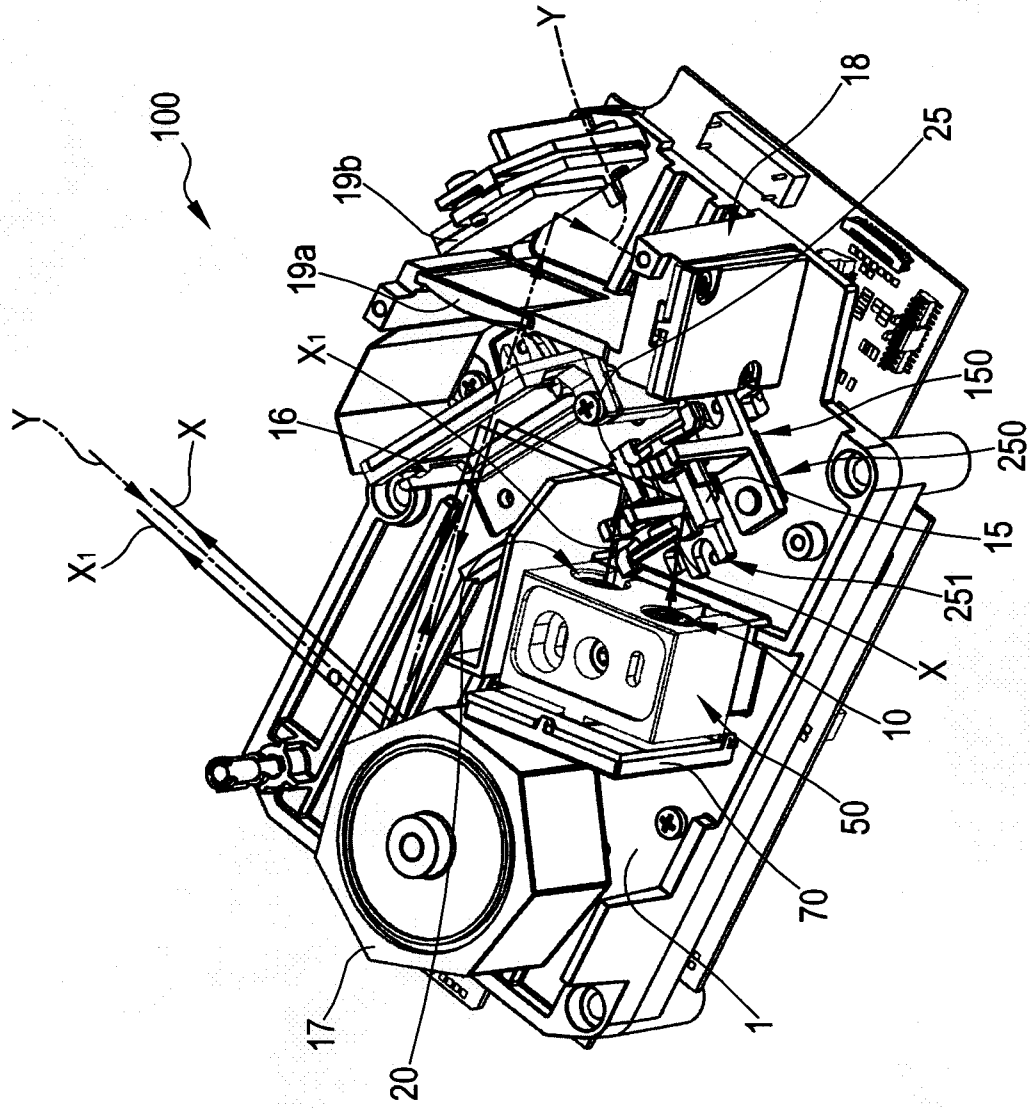

FIG.1

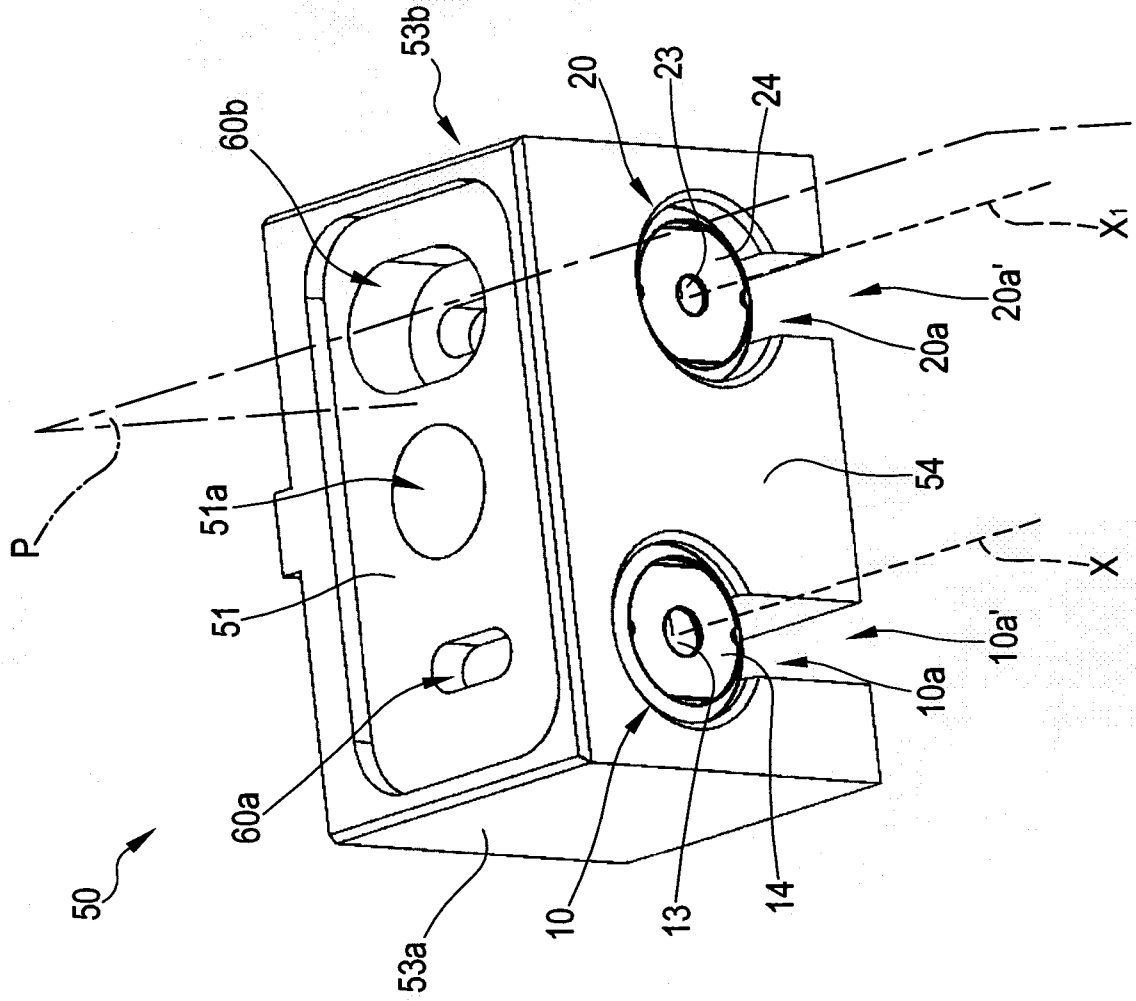

FIG. 2

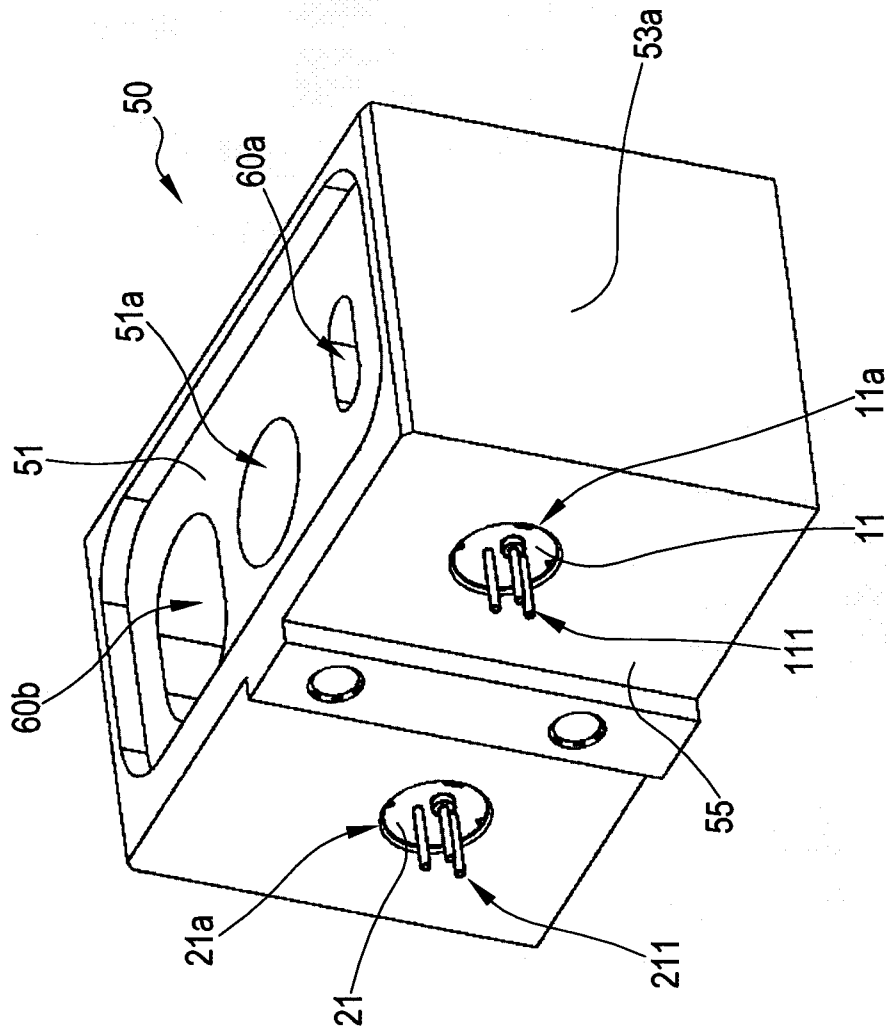

FIG.3

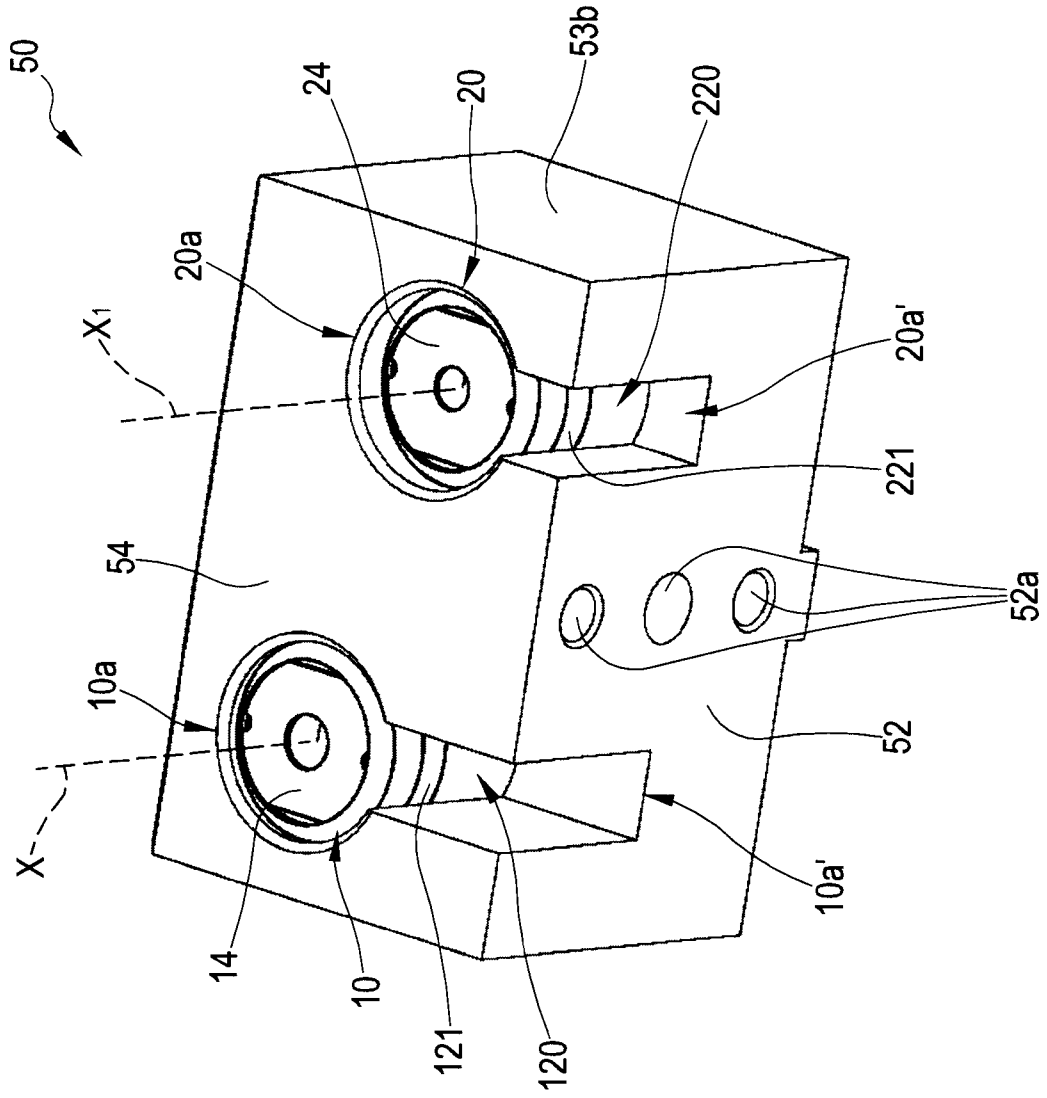

FIG. 4

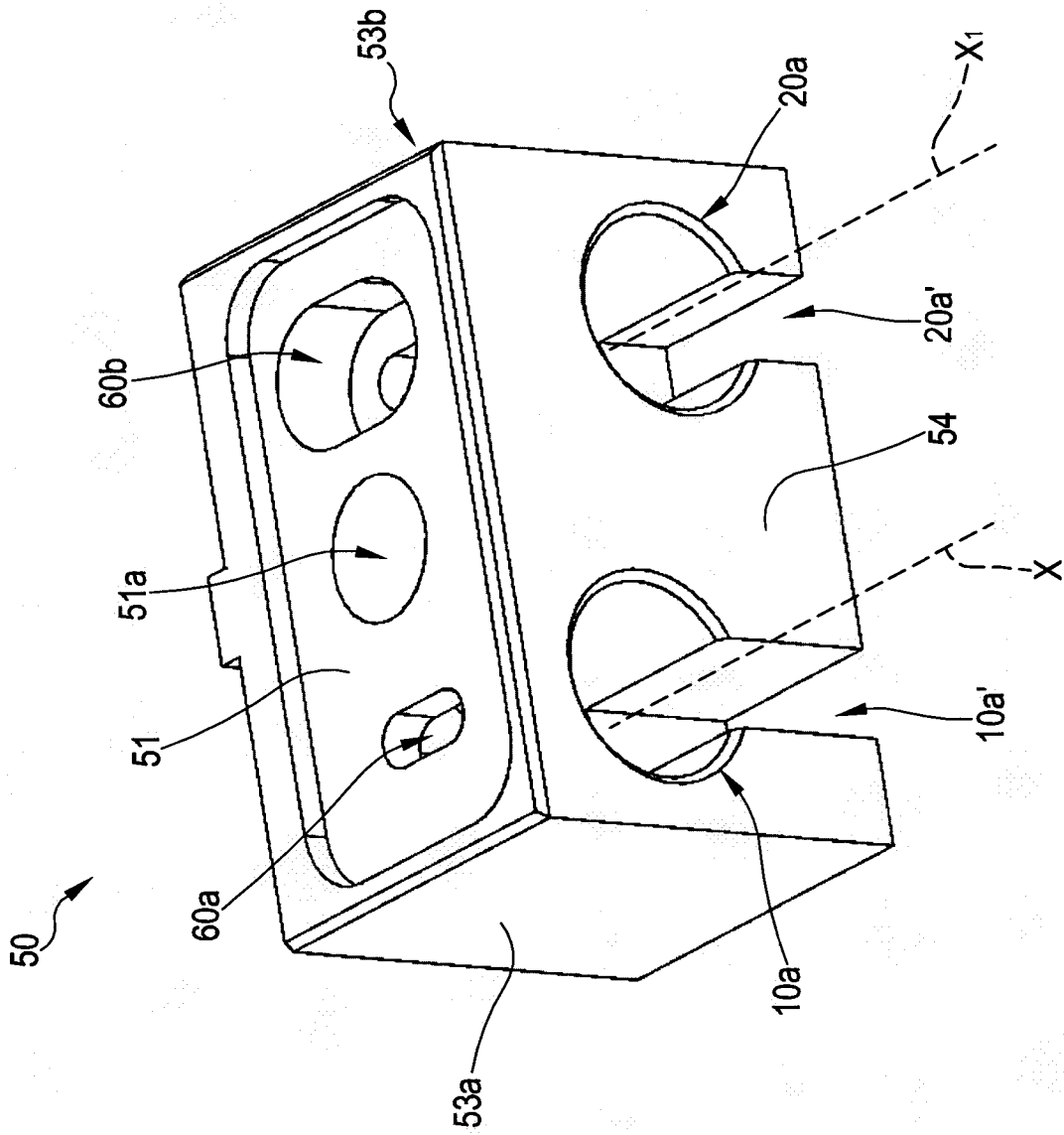

FIG.5

6/10

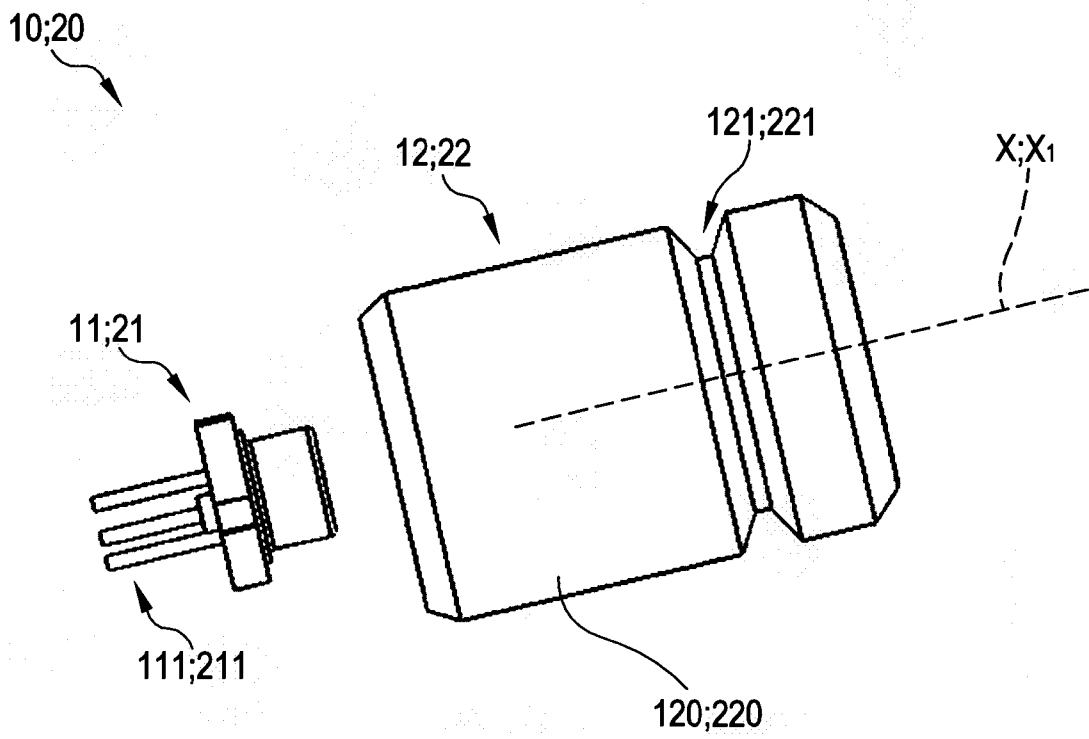

FIG.6

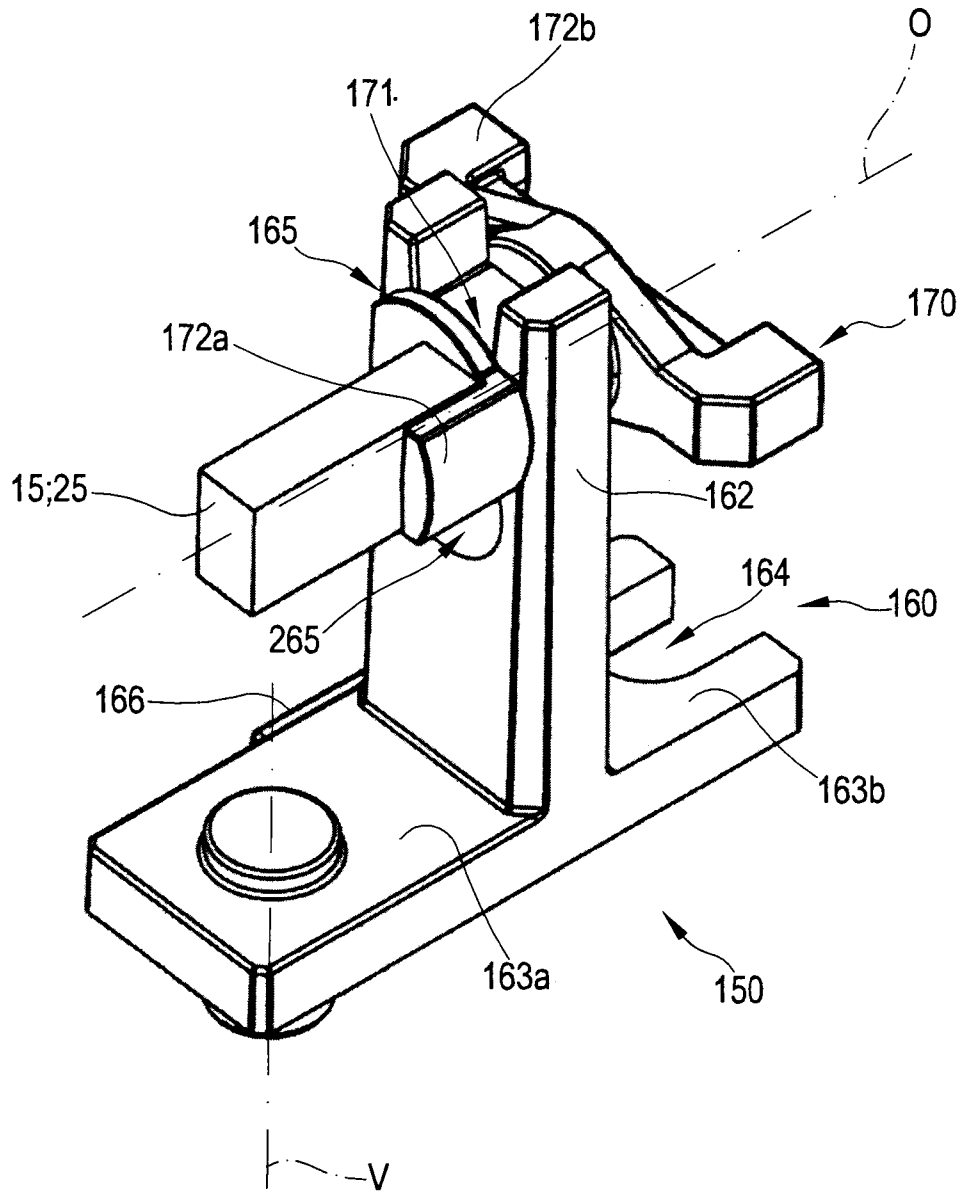

FIG.7

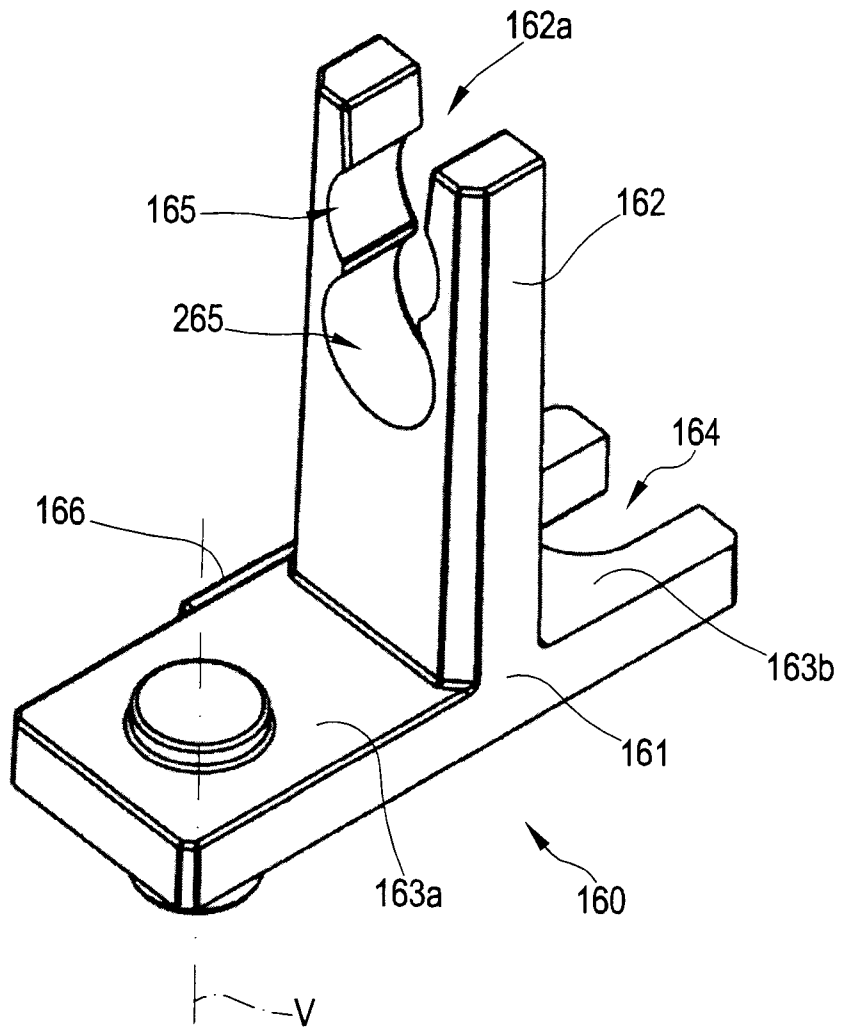

FIG.8

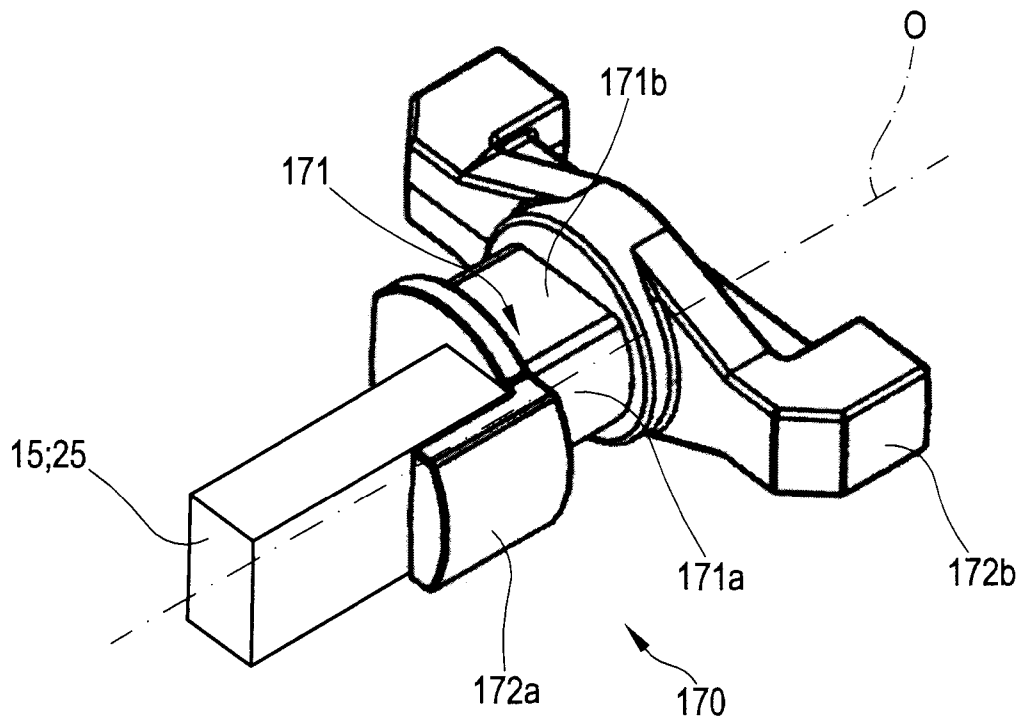

FIG.9

10/10

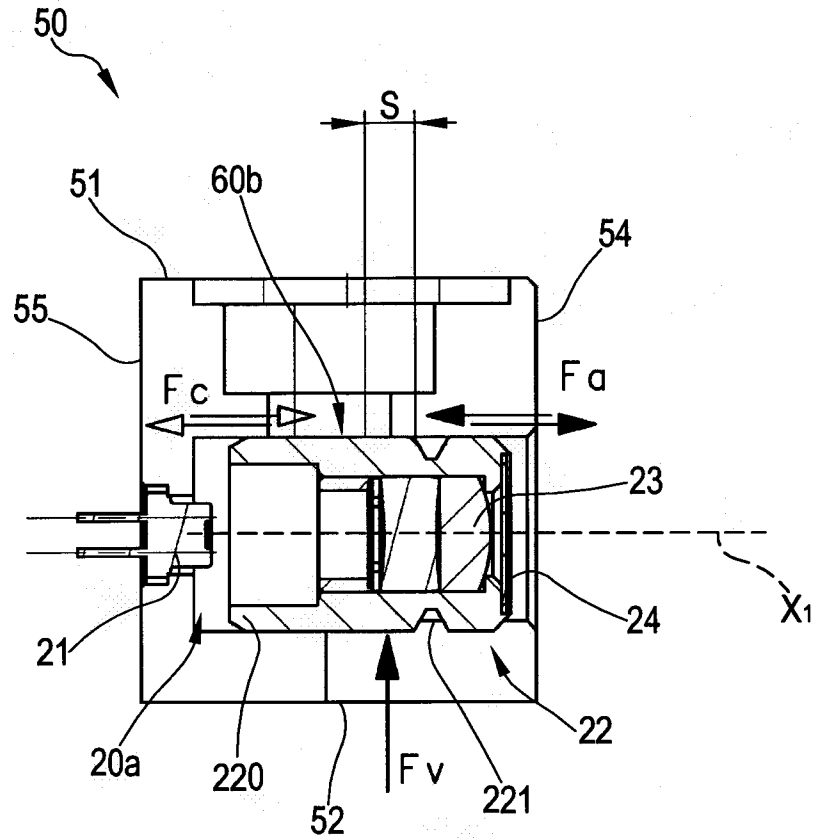

FIG.10

INTERNATIONAL SEARCH REPORT

International application No
PCT/IT2013/000221

A. CLASSIFICATION OF SUBJECT MATTER
INV. G02B7/02 G02B26/12 G06K7/10
ADD.

According to International Patent Classification (IPC) or to both national classification and IPC

B. FIELDS SEARCHED

Minimum documentation searched (classification system followed by classification symbols)
G02B G06K

Documentation searched other than minimum documentation to the extent that such documents are included in the fields searched

Electronic data base consulted during the international search (name of data base and, where practicable, search terms used)

EPO-Internal, WPI Data, COMPENDEX, INSPEC

C. DOCUMENTS CONSIDERED TO BE RELEVANT

Category*	Citation of document, with indication, where appropriate, of the relevant passages	Relevant to claim No.
X Y	US 2008/149726 A1 (KNOWLES C HARRY [US] ET AL) 26 June 2008 (2008-06-26) figures 5P,5X1-5X4 paragraphs [0173], [0189], [0190] -----	1-5,7, 20,22 8-17,19, 21
X Y	US 2005/024479 A1 (ITABASHI AKIHISA [JP] ET AL) 3 February 2005 (2005-02-03) figures 7,8 paragraphs [0118], [0209], [0211] -----	1-5,7, 20,22 6
X Y	US 2002/001118 A1 (NAKAJIMA TOMOHIRO [JP] ET AL) 3 January 2002 (2002-01-03) figures 9,5 paragraphs [0002], [0127], [0141] -----	1-5,7, 20,22
Y	US 2004/184127 A1 (NAKAJIMA TOMOHIRO [JP] ET AL) 23 September 2004 (2004-09-23) figures 4,6 -----	6
	-/--	

Further documents are listed in the continuation of Box C.

See patent family annex.

* Special categories of cited documents :

<p>"A" document defining the general state of the art which is not considered to be of particular relevance</p> <p>"E" earlier application or patent but published on or after the international filing date</p> <p>"L" document which may throw doubts on priority claim(s) or which is cited to establish the publication date of another citation or other special reason (as specified)</p> <p>"O" document referring to an oral disclosure, use, exhibition or other means</p> <p>"P" document published prior to the international filing date but later than the priority date claimed</p>	<p>"T" later document published after the international filing date or priority date and not in conflict with the application but cited to understand the principle or theory underlying the invention</p> <p>"X" document of particular relevance; the claimed invention cannot be considered novel or cannot be considered to involve an inventive step when the document is taken alone</p> <p>"Y" document of particular relevance; the claimed invention cannot be considered to involve an inventive step when the document is combined with one or more other such documents, such combination being obvious to a person skilled in the art</p> <p>"&" document member of the same patent family</p>
---	---

Date of the actual completion of the international search 3 June 2014	Date of mailing of the international search report 10/06/2014
--	--

Name and mailing address of the ISA/ European Patent Office, P.B. 5818 Patentlaan 2 NL - 2280 HV Rijswijk Tel. (+31-70) 340-2040, Fax: (+31-70) 340-3016	Authorized officer Girardin, François
--	--

INTERNATIONAL SEARCH REPORT

International application No.
PCT/IT2013/000221

Box No. II Observations where certain claims were found unsearchable (Continuation of item 2 of first sheet)

This international search report has not been established in respect of certain claims under Article 17(2)(a) for the following reasons:

1. Claims Nos.:
because they relate to subject matter not required to be searched by this Authority, namely:

2. Claims Nos.:
because they relate to parts of the international application that do not comply with the prescribed requirements to such an extent that no meaningful international search can be carried out, specifically:

3. Claims Nos.:
because they are dependent claims and are not drafted in accordance with the second and third sentences of Rule 6.4(a).

Box No. III Observations where unity of invention is lacking (Continuation of item 3 of first sheet)

This International Searching Authority found multiple inventions in this international application, as follows:

see additional sheet

1. As all required additional search fees were timely paid by the applicant, this international search report covers all searchable claims.
2. As all searchable claims could be searched without effort justifying an additional fees, this Authority did not invite payment of additional fees.
3. As only some of the required additional search fees were timely paid by the applicant, this international search report covers only those claims for which fees were paid, specifically claims Nos.:

1-22
4. No required additional search fees were timely paid by the applicant. Consequently, this international search report is restricted to the invention first mentioned in the claims; it is covered by claims Nos.:

Remark on Protest

- The additional search fees were accompanied by the applicant's protest and, where applicable, the payment of a protest fee.
- The additional search fees were accompanied by the applicant's protest but the applicable protest fee was not paid within the time limit specified in the invitation.
- No protest accompanied the payment of additional search fees.

INTERNATIONAL SEARCH REPORT

International application No
PCT/IT2013/000221

C(Continuation). DOCUMENTS CONSIDERED TO BE RELEVANT		
Category*	Citation of document, with indication, where appropriate, of the relevant passages	Relevant to claim No.
Y	JP H05 22530 A (CANON KK) 29 January 1993 (1993-01-29) abstract figures 1,3	8-17,19, 21
A	----- US 2009/309952 A1 (AKATSU KAZUHIRO [JP]) 17 December 2009 (2009-12-17) abstract -----	8-19,21

INTERNATIONAL SEARCH REPORT

Information on patent family members

International application No PCT/IT2013/000221

Patent document cited in search report	Publication date	Patent family member(s)	Publication date
US 2008149726	A1	26-06-2008	US 2008110992 A1 15-05-2008
			US 2008110994 A1 15-05-2008
			US 2008121718 A1 29-05-2008
			US 2008121719 A1 29-05-2008
			US 2008121720 A1 29-05-2008
			US 2008128509 A1 05-06-2008
			US 2008128510 A1 05-06-2008
			US 2008135622 A1 12-06-2008
			US 2008142596 A1 19-06-2008
			US 2008142601 A1 19-06-2008
			US 2008142602 A1 19-06-2008
			US 2008149726 A1 26-06-2008
			US 2008156877 A1 03-07-2008
			US 2008169348 A1 17-07-2008
			US 2008185439 A1 07-08-2008
			US 2008249884 A1 09-10-2008
			US 2008283611 A1 20-11-2008
			US 2009065584 A1 12-03-2009
			US 2009101718 A1 23-04-2009
			US 2009101719 A1 23-04-2009
US 2005024479	A1	03-02-2005	NONE
US 2002001118	A1	03-01-2002	JP 4774157 B2 14-09-2011
			JP 2002166598 A 11-06-2002
			US 2002001118 A1 03-01-2002
US 2004184127	A1	23-09-2004	NONE
JP H0522530	A	29-01-1993	NONE
US 2009309952	A1	17-12-2009	JP 2010020278 A 28-01-2010
			US 2009309952 A1 17-12-2009

FURTHER INFORMATION CONTINUED FROM PCT/ISA/ 210

This International Searching Authority found multiple (groups of) inventions in this international application, as follows:

1. claims: 1-7, 20, 22

Reading device for reading coded information comprising two optical groups having each a light source and a lens, both optical groups being housed in seats formed in a single one-piece block, wherein the shape of the one-piece block is further specified.

2. claims: 8-19, 21

Reading device for reading coded information comprising two optical groups having each a light source and a lens, both optical groups being housed in seats formed in a single one-piece block, wherein barrels slidably coupled to the one-piece block are used to maintain the lenses, the one-piece block having though grooves for allowing access of tool maintaining the barrels in position during mounting.

3. claims: 23-35

Reading device for reading coded information comprising two optical groups having each a light source and a lens, both optical groups being housed in seats formed in a single one-piece block, further comprising deflecting mirrors being provided on adjustment members.

4. claims: 36-43

Method for focusing a reading device for reading coded information comprising one optical group having a light source and a lens, the optical group being housed in a seat having an aperture for introducing an adhesive, wherein the holding force applied to the lens during solidification of the adhesive counter-balance the force exerted on the lens by the adhesive.
