



US 20100011865A1

(19) **United States**

(12) **Patent Application Publication**
SAXENA et al.

(10) **Pub. No.: US 2010/0011865 A1**

(43) **Pub. Date: Jan. 21, 2010**

(54) **APPARATUS AND METHOD FOR DAMAGE LOCATION AND IDENTIFICATION IN STRUCTURES**

Related U.S. Application Data

(60) Provisional application No. 61/081,706, filed on Jul. 17, 2008.

(76) Inventors: **Indu SAXENA**, Torrance, CA (US); **Lothar Kempen**, Redondo Beach, CA (US); **Chai Tea**, El Monte, CA (US)

Publication Classification

(51) **Int. Cl.**
G01N 29/00 (2006.01)
G02B 6/00 (2006.01)

(52) **U.S. Cl.** **73/632; 385/13**

(57) **ABSTRACT**

An apparatus and method for testing composite structures in which ultrasonic waves are used to detect disbonds in the structures are described. The apparatus comprises a flexible structure carrying acousto-optical transducers such as fiber Bragg gratings. During use, the apparatus is mechanically and conformally coupled to the structure under test.

Correspondence Address:
Steinfl & Bruno
301 N Lake Ave Ste 810
Pasadena, CA 91101 (US)

(21) Appl. No.: **12/504,595**

(22) Filed: **Jul. 16, 2009**

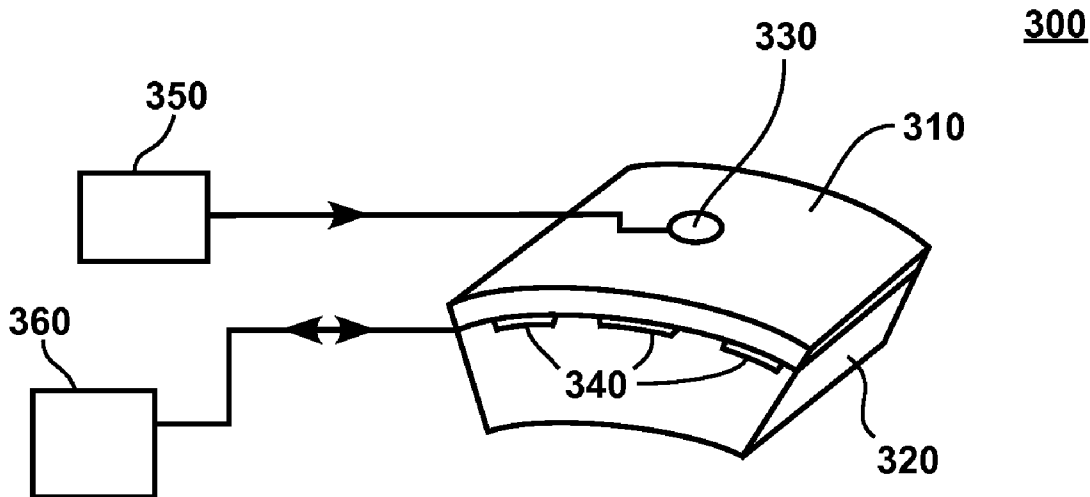

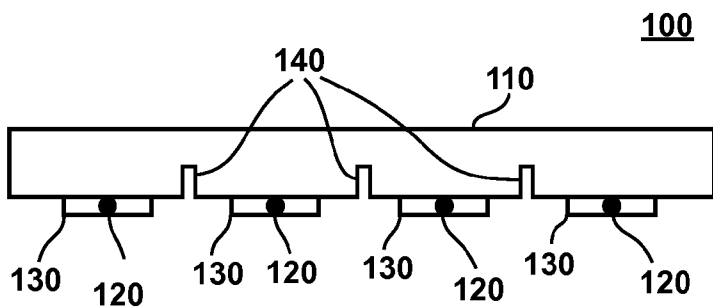

FIG. 1

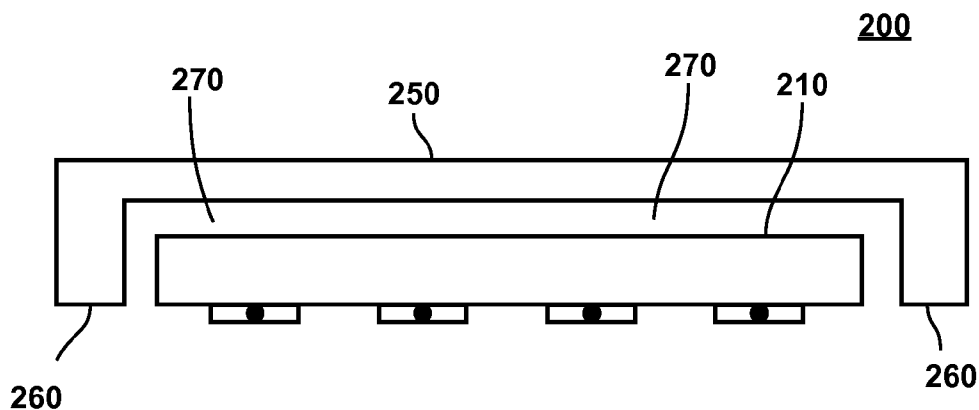

FIG. 2

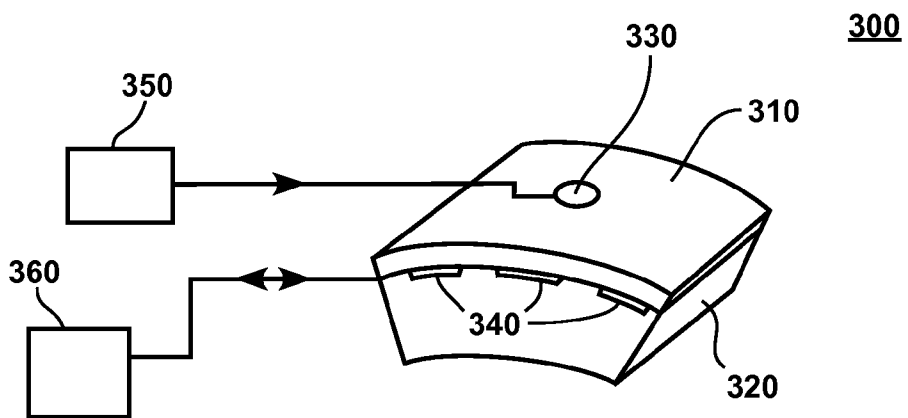

FIG. 3

400

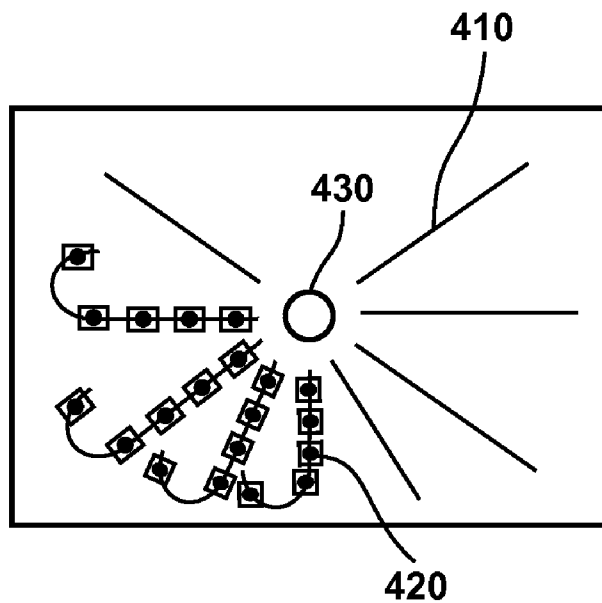

FIG. 4

500

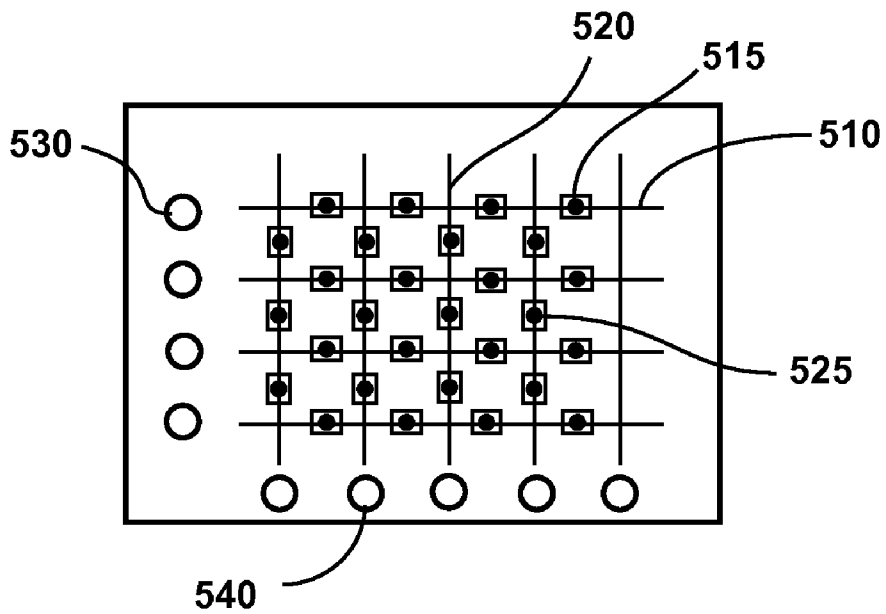

FIG. 5

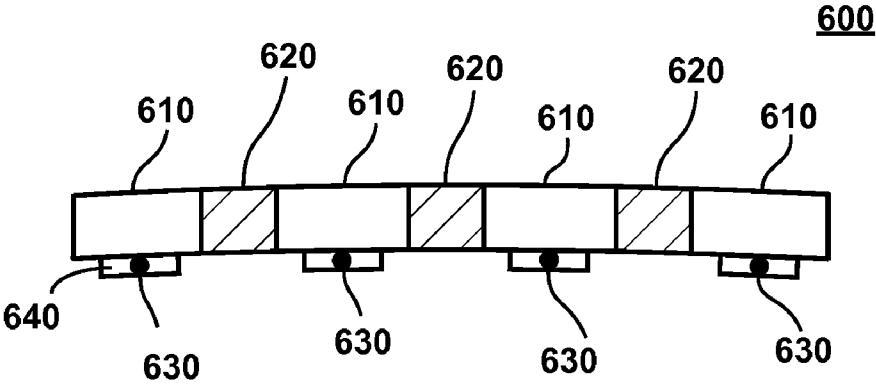

FIG. 6

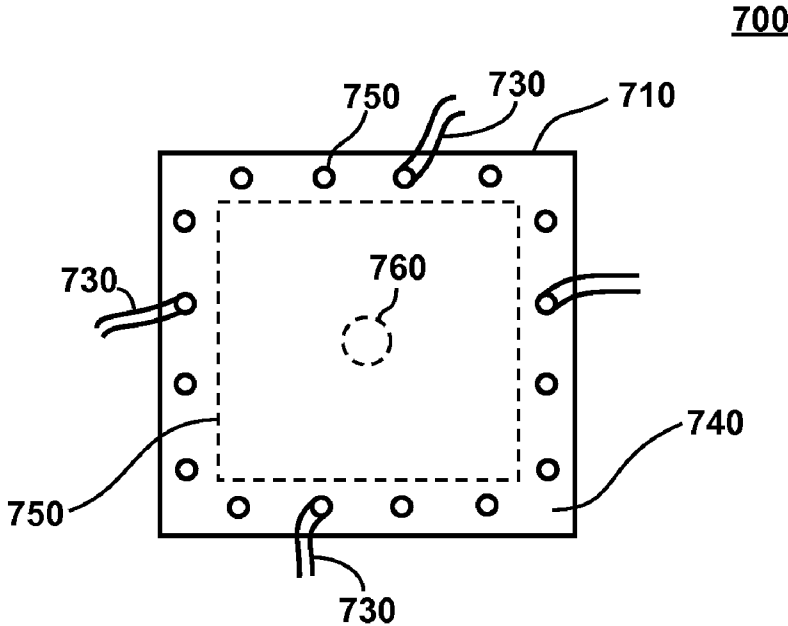

FIG. 7

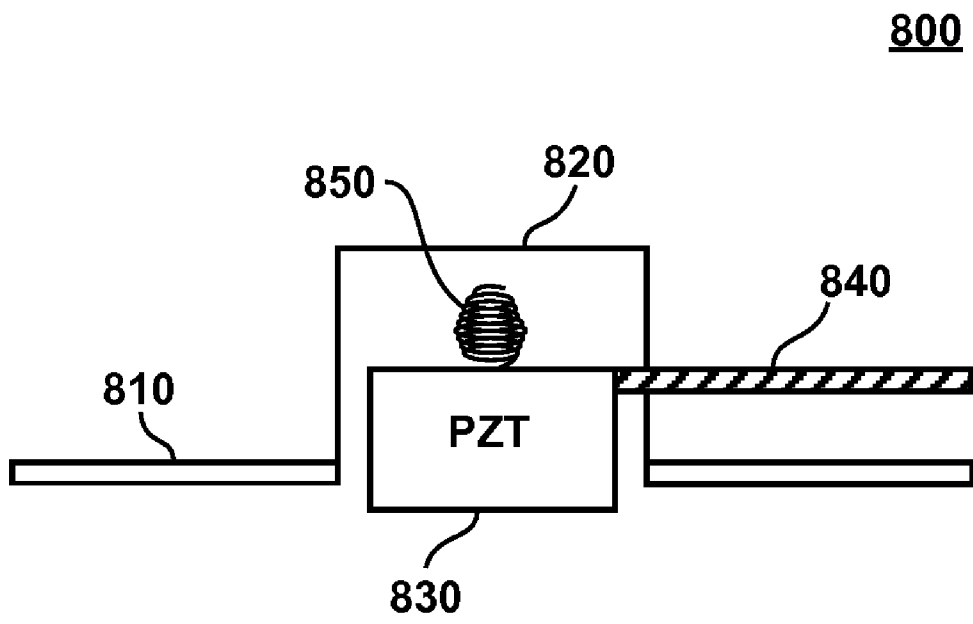

FIG. 8

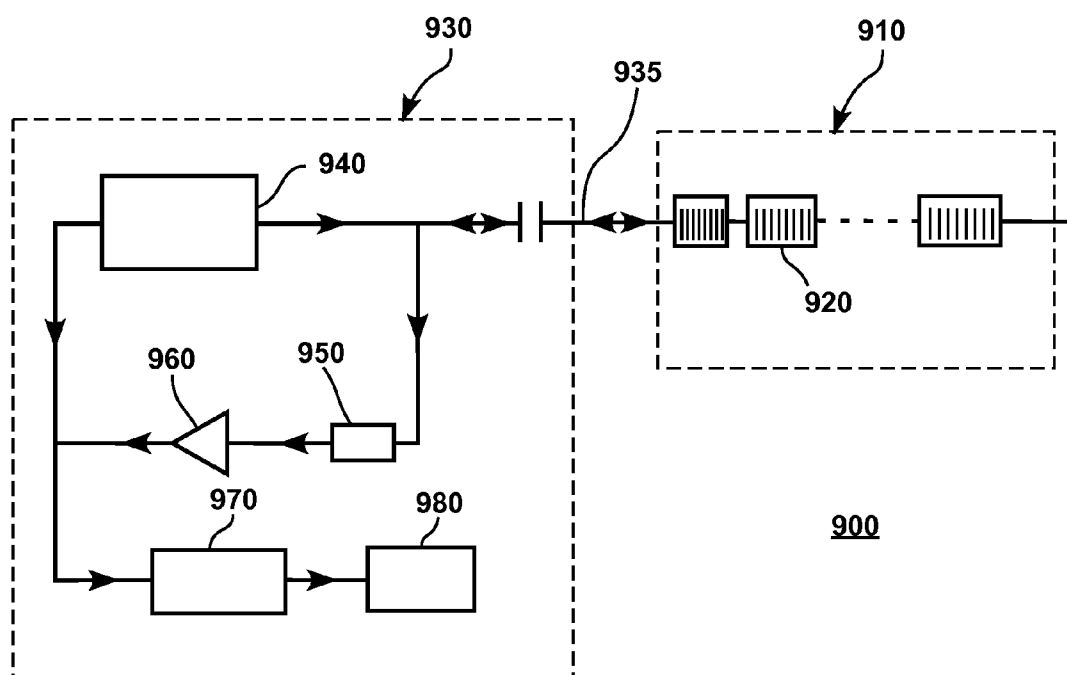

FIG. 9

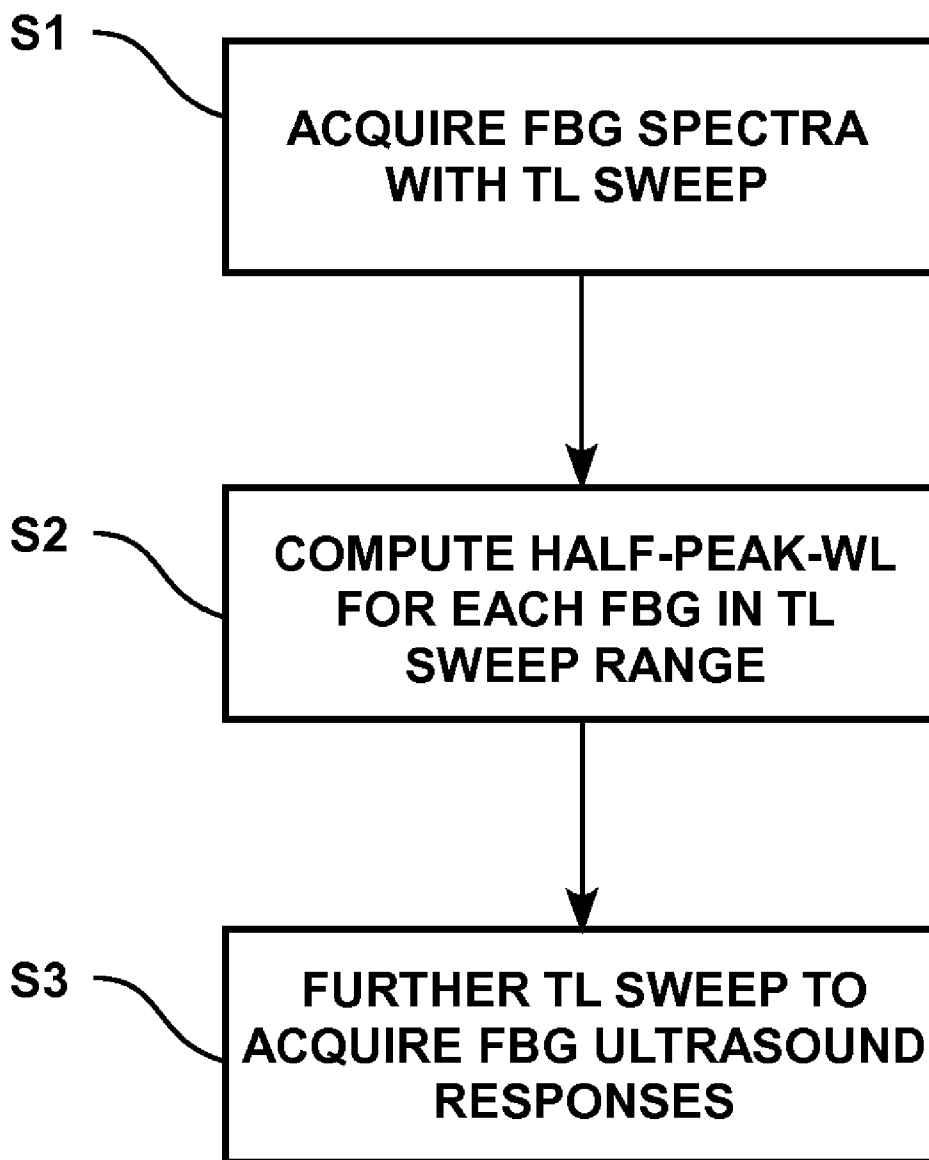

FIG. 10

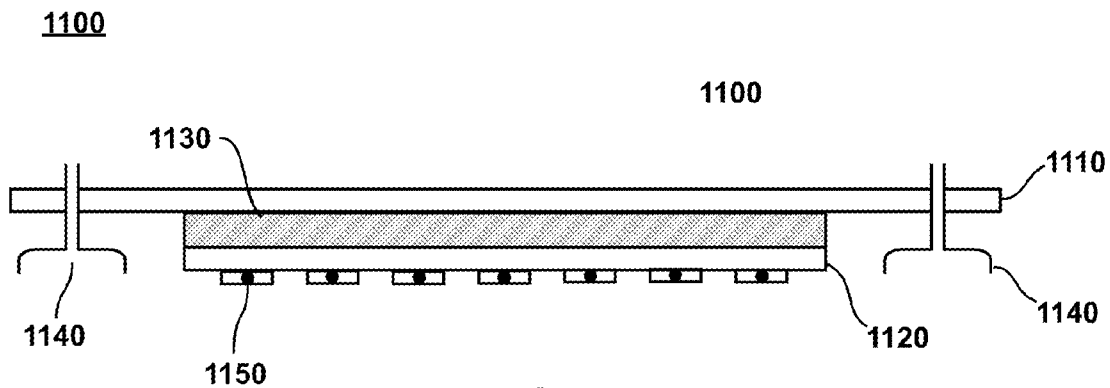

FIG. 11

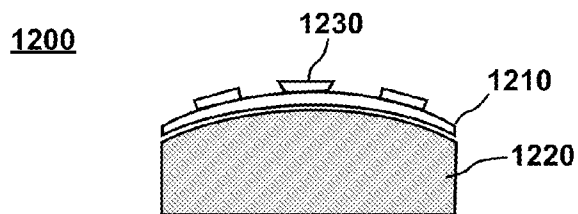

FIG. 12

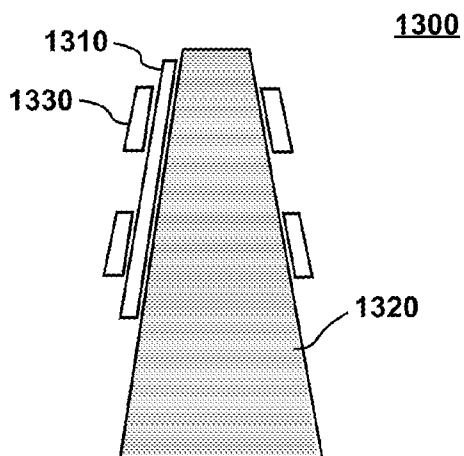

FIG. 13

1400

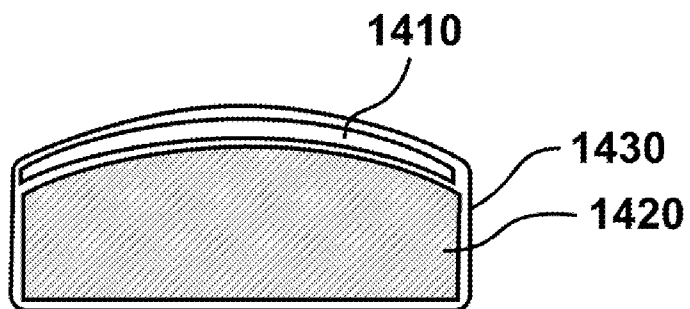

FIG. 14

1500

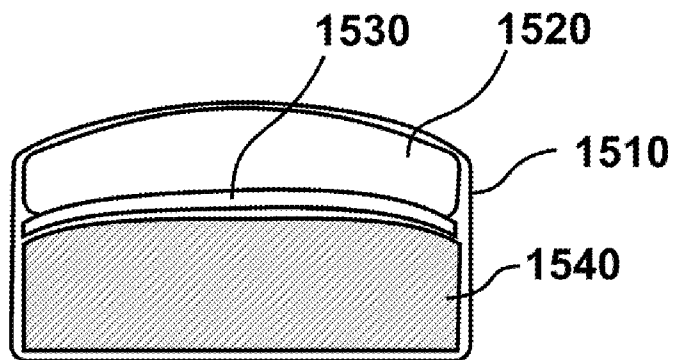

FIG. 15

APPARATUS AND METHOD FOR DAMAGE LOCATION AND IDENTIFICATION IN STRUCTURES

CROSS REFERENCE TO RELATED APPLICATIONS

[0001] The present application claims priority to U.S. Provisional Application 61/081,706 filed on Jul. 17, 2008, which is incorporated herein by reference in its entirety.

STATEMENT OF GOVERNMENT GRANT

[0002] This invention was made with Government support under contract numbers FA8501-06-M-0106 and FA8501-07-C-0025 from the U.S. Air Force. The Government may have certain rights in this patent.

FIELD

[0003] The present disclosure relates to an apparatus and method for damage location and identification in structures. More in particular, it relates to an apparatus and method for noninvasive detecting and locating of defects in composite structures using ultrasonic waves.

BACKGROUND

[0004] Measurement of ultrasonic vibrations by means of fiber Bragg gratings (FBGs) that are embedded into the component under test or glued to the component surface are discussed, for example, in "Acousto-ultrasonic sensing using fiber Bragg gratings", Daniel C Betz et al, 2003 Smart Mater. Struct. 12 122-128 or "Impact wave and damage detections using a strain-free fiber Bragg grating ultrasonic receiver", Jung-Ryul Lee et al, NDT & E International Volume 40, Issue 1, January 2007, 85-93.

SUMMARY

[0005] According to a first aspect of the present disclosure, a method for nondestructive testing of structures is provided, comprising: causing an ultrasonic wave to traverse a portion of a structure being tested for presence of defects, to cause surface displacements in the structure; providing one or more optical waveguides attached to a flexible structure, each optical waveguide comprising one or more spaced apart transducers adapted to respond to the surface displacements; locating the one or more transducers in mechanical contact with the surface of the structure under test for a transducer response corresponding to the surface displacements of the structure at respective locations of the transducers caused by the ultrasonic wave; obtaining modulation of the one or more transducers in response to the surface displacements of the structure; based on the response of the one or more transducers, reconstructing distribution characteristics of the ultrasonic waves across the structure; and based on the reconstructed distribution characteristics, determining likely locations of features in the structure, such as damages.

[0006] According to a second aspect of the present disclosure, a nondestructive evaluation apparatus for use in responding to surface displacements caused by ultrasonic waves on a surface of a material or structure under test is provided, the apparatus comprising: a flexible structure having attached thereto one or more optical waveguides, each optical waveguide comprising at least one acoustic-optical transducer, wherein the flexible structure is adapted to follow

the surface displacements in strain and/or bending such that modulation of the at least one acoustic-optical transducer is communicated through the optical waveguide to enable processing to determine information on the surface displacement.

[0007] According to a third aspect of the present disclosure, an apparatus for determining locations of delaminations and/or disbonds in a composite piece part is provided, comprising: an acoustic source for generating, during operation of the apparatus, ultrasonic waves in the composite piece part; and a compliant planar member connected with the acoustic source and adapted for conforming to at least a portion of the composite piece part, the compliant planar member comprising one or more optical waveguide tracks located on a surface thereof, the one or more optical waveguide tracks comprising at least one FBG acoustically coupled to the acoustic source, the at least one FBG acting, during operation of the apparatus, as an acousto-optical transducer of acoustic signals generated by the acoustic source, the at least one FBG located at a predetermined distance from the acoustic source.

[0008] According to a fourth aspect, an apparatus comprising a dimensionally stable, conformable member having a first and at least one second location separated by a known distance is provided, wherein a source of ultrasonic energy is located at the first location and at least one acousto-optical transducer is located at the at least one second location, the source being adapted to be acoustically coupled to the at least one optical transducer by placement of the conformable member on a device under test.

[0009] According to a fifth aspect, a method to determine dynamic strain and/or bending of one or more optical filters is provided, comprising: performing a first sweeping of a tunable laser to acquire reflection spectra of the one or more optical filters; for each optical filter, determining a feature of the reflection spectrum of that optical filter; and performing a second sweeping of the tunable laser to acquire acousto-ultrasound responses of the one or more optical filters.

[0010] Further aspects of the present disclosure are provided in the specification, drawings and claims of the present application.

BRIEF DESCRIPTION OF THE DRAWINGS

[0011] FIG. 1 shows a cross-sectional view of an embodiment of a flexible sheet or panel comprising a plurality of FBGs according to the disclosure.

[0012] FIG. 2 shows a cross-sectional view of another embodiment of the flexible sheet or panel, where a suction cup is also provided.

[0013] FIG. 3 shows a schematic perspective view of an arrangement, where a flexible sheet or panel is coupled to a composite structure.

[0014] FIG. 4 shows a bottom view of the flexible sheet or panel of the present disclosure where a first example of disposition of the FBGs is shown.

[0015] FIG. 5 shows a bottom view of the flexible sheet or panel of the present disclosure where a second example of disposition of the FBGs is shown.

[0016] FIG. 6 shows a cross-sectional view of a further arrangement of the flexible sheet or panel.

[0017] FIG. 7 shows a top view of the flexible sheet or panel.

[0018] FIG. 8 shows a cross-sectional view of a PZT source to be used in accordance with the teachings of the present disclosure.

[0019] FIG. 9 shows an example of a control arrangement of the flexible sheet or panel.

[0020] FIG. 10 shows a flow chart of a tunable laser sweeping technique in accordance with the disclosure.

[0021] FIG. 11 shows a cross-sectional view of a further embodiment of the flexible sheet or panel, where suction cups located on the side of the sheet or panel are provided.

[0022] FIGS. 12 and 13 show cross-sectional views of further embodiments of the flexible sheet or panel, where magnetic holders are provided.

[0023] FIGS. 14 and 15 show cross-sectional views of further embodiments of the flexible sheet or panel, where an external cover is provided.

DETAILED DESCRIPTION

[0024] The structure to be imaged through ultrasonic inspection in accordance with the teachings of the present disclosure can be any structure capable of transmitting ultrasound from the source to the receiving elements. By way of example, such structure can include simple single plate-like structures including either metals or polymers or composites, where polymers include resins. By way of further example, the structure can include compound plate-like structures that are multiple layers of either metals or composites or both. The second layer that the composite is adhered to can be a metal honeycomb or a polymer, e.g. a Nomex® honeycomb.

[0025] FIG. 1 shows a cross-sectional view of an embodiment of a flexible sheet or panel comprising a plurality of FBGs according to the disclosure. In particular, the embodiment of FIG. 1 shows an ultrasound imaging device (100) comprising a flexible sheet or panel (110) to which a plurality of FBGs (120), possibly enclosed by coatings or encasings (130), is connected.

[0026] The FBGs (120) are adapted to be acoustically coupled, e.g. through friction, to a surface on an object under test, not shown in the figure. In order to strengthen the mechanical contact between the FBGs and the surface of the object under test, a plurality of suction pockets (140) can be provided. Once the suction pockets (140) are actuated (e.g., through suction hoses not shown in the figure), the mechanical contact between the flexible sheet or panel (110) and the surface of the object under test is increased due to ambient air pressure.

[0027] The functions of flexible sheet or panel (110) are (i) conformability to the shape of the component under test, (ii) to be dimensionally stable, i.e. to provide a predetermined lateral position of the transducers with respect to the acoustic source and to each other, if more than one, and (iii) provide sufficient mechanical pressure to each of the transducers such that acoustic coupling between transducer and surface is provided.

[0028] Flexible sheet or panel (110) has sufficient flexibility to conform to the shape of the component under test and to allow for the FBGs to be compressed, stretched, and/or bent by the ultrasonic surface deformations of the component under test and to hold the FBGs in place by exerting a force on them as they are acoustically coupled to the component. This flexibility allows the sheet or panel to conform to non-planar surfaces of such component.

[0029] By way of example, the flexible sheet or panel can be a flexible sheet or panel made of metal, polymer, or rubber of uniform or non-uniform thickness, such as tapered or ribbed, for instance, with a regular or irregular pattern and/or embossing. The surface of the sheet or panel should provide

substantially uniform pressure over the area of any single transducer to permit good acoustic contact at the transducer. The flexibility of the sheet or panel can be such that it allows bending to the extent that the embedded fiber is not prone to breakage when the sheet or panel is bent.

[0030] The flexible sheet or panel is able to conform to the surface shape such that the transducers are in good acoustic contact. Therefore, different hardness polymers can be used, depending on the potential curvature of the surface under test. According to an embodiment of the disclosure, the flexible sheet or panel is a poor acoustic waveguide itself, in order not to influence the measurement of the material under test. A flexible sheet or panel according to such embodiment could be, for example, a flexible sheet or panel made of rubber.

[0031] As mentioned above, the mechanical contact between the FBGs and the surface of the structure under test can be strengthened through mechanical means such as underpressure between the sheet or panel (110) and the surface, causing ambient air to press the sheet or panel against the surface.

[0032] An alternative mechanical means to increase such contact is shown in the embodiment of FIG. 2.

[0033] FIG. 2 shows a cross-sectional view of another embodiment of the flexible sheet or panel, where a suction cup is also provided. In particular, the embodiment of FIG. 2 shows an ultrasound imaging device (200) comprising a flexible sheet or panel (210) similar to the embodiment of FIG. 1 coupled with a suction cup (250), e.g. a polyurethane suction cup. During operation of the ultrasound imaging device (200), underpressure (i.e. formation of vacuum) in the region (270) is obtained, thus providing a stronger contact between sheet or panel (210) and the surface of the device under test. If desired, compressible foam can be located in the region (270) between flexible sheet or panel (210) and suction cup (250). The embodiment of FIG. 2 will also be later discussed, with reference to the depiction of FIG. 6.

[0034] The embodiment of FIG. 2 shows an evacuation technique where the entire lid (250) gets evacuated. Alternative embodiments are possible where, for example, suction cups are attached to a side of the lid, which is rigid, and pushes down on sheet or panel (210) when underpressure is formed. Reference can be made, for example, to the embodiment of FIG. 11, where a rigid pressure plate or lid (1110) is located on top of a compressible sheet (1120) (e.g., a compressible soft polymer sheet), with a layer (1130) of compressible foam located between the two. Also shown in FIG. 11 are vacuum suction cups (1140) (e.g., polyurethane cups) on the sides of the structure.

[0035] Increasing the acoustic contact between the optical transducers that are embedded in a flexible backing and the surface of the structure under test can also be achieved by applying mechanical force directly instead of a suction-induced force. This can be obtained through the use of hydraulic pressure or by the use of known weights.

[0036] For the structures under test whose acousto-ultrasonic characteristics are measured and that are made of materials containing iron, cobalt or nickel, a magnet can be provided to apply pressure to the flexible sheet or panel of transducers, as shown in FIG. 12, where a flexible sheet or panel (1210) located on a structure or device under test (1220) and three magnetic holders (1230) are depicted. Non-magnetic structures like, for example, structure (1320) of FIG. 13, can have two magnets (1330) on either side of the structure

(1320) to hold the flexible sheet or panel (1310) on one side or both sides of the structure (1320).

[0037] Another method can be the use of a mechanical “pull” from a part that has some elastic or tensioning capability that goes (at least partly) around the flexible sheet or panel contacting the structure under test, as in FIG. 14, where a flexible sheet or panel (1410) located on a structure or device under test (1420) are shown, and where both the sheet and the structure are embedded into a cover or sock (1430). By way of example, a strap around the vertical stabilizer wing could produce pressure onto the panel by being pulled tight or by being partly elastic. Additionally, also a more loose fitting rigid non-elastic strap or “sock” (1510) can be provided, in which an inflatable element (1520) is interspersed between such sock (1510) and the flexible sheet or panel (1530) to provide the pressure between panel (1530) and surface (1540) when inflated, as shown in FIG. 15.

[0038] Therefore, upon reading of the above explained embodiments of FIG. 1 and FIG. 2, the person skilled in the art will understand that a flexible sheet or panel containing the FBGs can conveniently be temporarily attached and removed from the component surface, and thus can be used for rapid subsequent measurements of multiple sections on a larger surface or for testing multiple components with the same FBG transducers.

[0039] The sheet or panel has sufficient flexibility to allow for the FBGs to be compressed, stretched, and/or bent by the ultrasonic surface deformations of the component under test. Flexibility of the sheet or panel makes it possible to test parts with complex shapes, such as encountered in aircraft components and multiple other applications. The sheet or panel is lightweight and convenient to handle and attach.

[0040] FIG. 3 shows a schematic perspective view of an arrangement (300), where a flexible sheet or panel (310) is coupled to a composite structure (320). By way of example, a surface wave, also called Lamb wave, is generated along the composite structure (320) through an ultrasonic source (330), such as a piezoelectric (PZT) transducer. The surface wave thus generated is detected by the FBGs (340). Ultrasonic source (330) can be powered by ultrasonic generator (350), while the FBG powering/control and readout circuitry, including a processor, is generally indicated with (360) and will be later shown in detail with reference to the embodiment of FIG. 9.

[0041] FIG. 4 shows a bottom view of the flexible sheet or panel of the present disclosure where a first example of disposition of the FBGs is shown. In particular, the embodiment of FIG. 4 shows, as seen from a bottom or contact surface, a flexible sheet or panel (400) having attached a plurality of optical fiber tracks (410), on which FBGs (420) are located. Some of the optical fibers (410) have a curved shape, so that additional FBGs (420) can be located on the same optical fiber. Also shown in FIG. 3 is a PZT source (430).

[0042] FIG. 5 shows a bottom view of the flexible sheet or panel of the present disclosure where a second example of disposition of the FBGs is shown. In particular, the embodiment of FIG. 5 shows, as seen from a bottom or contact surface, a flexible sheet or panel (500) having attached a plurality of horizontal optical fiber paths or tracks (510) and a plurality of vertical optical fiber paths or tracks (520) in a matrix configuration. The FBGs can be located (515) on the horizontal tracks (510) and/or be located (525) on the vertical

tracks (520). Also shown in the figure are a first plurality of PZT sources (530) and a second plurality of PZT sources (540).

[0043] The embodiments of FIG. 5 and FIG. 6 show two examples of spaced apart FBGs acting as ultrasonic receivers. The FBGs are spaced apart at known distances from the acoustic source (e.g., the PZT source) along their respective optical fibers. Each FBG along a fiber corresponds to a different Bragg wavelength, so that the reflected signal can be associated with a specific FBG. The FBGs detect the wave by strain and/or bending and the amount of the measured strain and/or bending is correlated with the wave amplitude. Then the location of any such strain and/or bending can be determined by processing the matrix of properties such as a wave amplitude and/or time of arrival. In particular, the use of a flexible sheet or panel having a plurality of optical fibers with spaced apart FBGs provides multiple ultrasonic measurements on the structure under test at pre-determined locations as sensed by the FBGs.

[0044] Therefore, by using a plurality of sensing locations in a matrix or non-matrix configuration, the wave amplitude can be determined at a plurality of points and then the location of strain and/or bending can be determined through an algorithm that processes the FBG locations and the measured wave properties. In this way, the distribution of ultrasonic waves across the component surface is reconstructed, and information about the structural integrity of the component is gained.

[0045] FIG. 6 shows a cross-sectional view of a further arrangement of the compliant member (e.g., a net) or flexible sheet/panel. In particular, the embodiment of FIG. 6 shows an ultrasound imaging device (600) comprising rigid sections (610) interleaved with flexible sections (620). In the embodiment of FIG. 6, the FBGs (630) are located in correspondence of the rigid sections (610). Therefore, in the embodiment of FIG. 6 flexibility of the device (600) is obtained through the presence of the flexible sections or regions (620).

[0046] FIG. 7 shows a top view of the flexible sheet or panel. In particular, the embodiment of FIG. 7 corresponds to the embodiment of FIG. 2 and shows a plan view of suction cup (710) which comprises a plurality of holes (720) with inserted suction hoses (730) to create underpressure in a region (740) between top suction cup (710) and bottom flexible sheet or panel (750). Also shown in FIG. 7 is a PZT source (760) located in the flexible sheet or panel (750).

[0047] Location of PZT sources on ultrasound imaging devices is known per se to the person skilled in the art and will not be discussed here in detail. FIG. 8 shows a way devised by applicants to integrate a PZT source on the top surface of the suction cup previously discussed in FIG. 7. More in particular, FIG. 8 shows a cross-sectional view of an arrangement (800), where a pressure plate (810), such as suction cup (710) of FIG. 7, is provided with an aluminum casing (820) containing a PZT source (830) powered by an acoustic generator (not shown) through a cable (840) and held in place into the casing by a spring (850) or any elastic material.

[0048] FIG. 9 shows an example of a control arrangement of the flexible sheet or panel. In particular, the schematic diagram of FIG. 9 shows an arrangement (900) comprising a flexible sheet or panel (910)—which includes a plurality of FBGs (920)—and a control system (930). While this system shows the reflected signal from the FBGs going to the photodetector, a signal transmitted by the FBGs can alternatively be used by optically coupling the fiber end to the photodetec-

tor. The flexible sheet or panel (910) and the control and/or processing system (930) are optically connected (935). The control system (930) comprises a tunable laser (940), a photodetector (950), feedback circuitry (960), a data acquisition and signal processing module (970), and a display (980).

[0049] In operation, the tunable laser (940) optically powers the FBGs (920), while the photodetector (950) receives, in reflection (or transmission), the modulated outputs of the FBGs (920) and sends them to the signal processing module or processor (970), which analyzes the data and displays them on display (980). In particular, the resulting modulation in reflection wavelength on each FBG (920) is used for reconstructing the distribution of ultrasonic waves across the component surface, and consequently for gaining information about the structural integrity of the component.

[0050] If desired, the readout circuitry can also include one or more additional PZT transducers, located at a distance from the PZT transducer acting as an ultrasonic source, e.g. 6 cm, for sensing waves at defined points. By way of example, each PZT transducer can operate at frequencies up to 1.5 MHz, and the source signal can be a single cycle sine pulse with a center frequency of 250 kHz and 10 Volts.

[0051] In the following paragraphs, a dynamic strain readout process or method in accordance with an embodiment of the present disclosure will be described. The process described below performs readout while compensating for static effects at the FBG locations. Reference will be made to FIG. 10.

[0052] In a first step S1, FBG spectra are acquired by sweeping a tunable laser (TL), see, e.g., laser (940) of FIG. 9. More in particular, a wavelength swept tunable laser is scanned/swept while incident on a fiber with one or many FBGs, see, e.g., elements (910) and (920) of FIG. 9. The reflected/transmitted intensity as a function of time is obtained. When the time scale is calibrated to wavelength, this intensity variation represents the (one or many) FBG spectra.

[0053] In a second step S2, one or both of the two wavelengths at half-peak intensity of the FBG reflection spectrum (half-peak-WL) are determined for each FBG in the entire TL sweep range and stored. For example, the peak intensity of the FBG spectra is determined and one or both of the half maxima (for reflection) or minima (for transmission) intensity are determined, called the "half-peak-WL". These values are computed from the spectra and stored for all the FBGs that are "read" in a single sweep/scan made by the TL. The person skilled in the art will also understand that other wavelengths can be acceptable, such as wavelengths within a quarter linewidth distance from the half-peak-WL, where a linewidth is defined as full width half maximum (FWHM) of the reflected spectrum.

[0054] In a third step S3, a further sweep of the TL is performed (e.g., within minutes of reading the FBG spectra and storing the half-peak-WLs as above), during which the following sub-steps are performed: (a) stop at the first FBG's stored half-peak-WL for a sufficient time to acquire an acousto-ultrasound response at this FBG location; (b) go to the next FBG's half-peak-WL and repeat acousto-ultrasound response acquisition; and (c) repeat until all FBG's ultrasound responses are acquired. Therefore, this additional sweep is not a continuous sweep, because it stops at the previously stored half-peak-WLs of each FBG.

[0055] It should be noted that the time difference between storing of the half-peak-WL's in the second step and acquisi-

tion of the acousto-ultrasonic responses in the third step is a time period during which significant temperature changes are not expected to occur, for instance less than a few minutes.

[0056] In the case where several optical fiber strands having (one or many) identical FBGs of identical spectra are used, an optical switch can be provided, to re-direct each TL sweep to each individual fiber strand and repeat the double sweeping process above to acquire acousto-ultrasonic response at all FBG locations.

[0057] The timing of the above described readout process will now be discussed. In general, the readout of the acousto-ultrasonic response is commenced after mounting of the acousto-ultrasonic imaging system on the device under test. During the process of placing the flexible sheet or panel comprising the transducers on the device under test the transducer or transducers could be subject to bending to conform to the curvature of the structure. In addition, the transducers could also undergo a change in temperature if the initial temperatures of the sheet and the device under test are different. Appropriate waiting time should be allowed for the temperature stabilization of the imaging device with the flexible sheet or panel. When the bending and the temperature changes have stabilized such that no significant static changes in these are to be deliberately performed or foreseen, the above readout process that compensates for all static changes that have occurred prior to this time, is commenced.

[0058] An embodiment of the above two-step sweeping process has been described with reference to FBGs. However, in addition to FBGs there are various other ways that a narrowband optical filter can be realized in optical waveguides that may yield a filtering action in reflection or transmission. These include Fabry-Perot cavities that are formed extrinsically at the end of the waveguide (and operated in reflection mode) or intrinsically in the middle of the waveguide. A Fabry-Perot cavity can be realized by having two parallel reflectors of variable reflectivity separated by an optical medium that is not opaque. The two reflectors may also be formed by two FBGs instead of two reflecting surfaces. The transmission or reflection spectrum of this device is then characterized by changes in the reflectivity and changes in the refractive index or the separation of the cavity thus formed, which thus responds to bends or axial stretches along an optical waveguide axis. Dynamic strain events, such as acousto-ultrasound, can be measured by the same two-step process described above.

[0059] By way of the above described embodiment, one or many locations of dynamic strain response can be measured in an automated fashion thus compensating for slowly changing static strain and/or temperature changes. Such changes would otherwise prevent the acquisition of a maximum dynamic strain response (off from the Quadrature-point) by causing a relative shift between the tunable laser and FBG spectra.

[0060] Optical filters such as fiber Bragg grating filters and Fabry-Perot cavities have been described above with reference to optical fiber waveguides. However, those versed in the art will understand that the teachings of the present disclosure can also apply, more generally, to optical waveguides not limited to optical fiber waveguides, such as rectangular waveguides.

[0061] The teachings of the present disclosure provide simple and effective tools in detecting damage in composite and/or metallic structures. The damage could be, for example, a disbond or delamination between the layers below the

superficial layer at which the ultrasound is launched into the object under test. The term “delamination” is defined to mean a localized failure of the bond between the composite layers of a composite structure. The term “disbond” is defined to mean a localized failure of the bond between a composite layer stack and the underlying structure, e.g. an aluminum honeycomb core. Such teachings can be used to develop structural health monitoring systems for aging as well as new aerospace and aircraft structures, resulting in significant reductions in the life cycle cost of these structures.

[0062] The examples set forth above are provided to give those of ordinary skill in the art a complete disclosure and description of how to make and use the embodiments of the apparatus and method for damage location and identification in structures of the disclosure, and are not intended to limit the scope of what the inventors regard as their disclosure. Modifications of the above-described modes for carrying out the disclosure may be used by persons of skill in the art, and are intended to be within the scope of the following claims. All patents and publications mentioned in the specification may be indicative of the levels of skill of those skilled in the art to which the disclosure pertains. All references cited in this disclosure are incorporated by reference to the same extent as if each reference had been incorporated by reference in its entirety individually.

[0063] It is to be understood that the disclosure is not limited to particular methods, apparatus or systems, which can, of course, vary. It is also to be understood that the terminology used herein is for the purpose of describing particular embodiments only, and is not intended to be limiting. As used in this specification and the appended claims, the singular forms “a,” “an,” and “the” include plural referents unless the content clearly dictates otherwise. The term “plurality” includes two or more referents unless the content clearly dictates otherwise. Unless defined otherwise, all technical and scientific terms used herein have the same meaning as commonly understood by one of ordinary skill in the art to which the disclosure pertains.

[0064] A number of embodiments of the disclosure have been described. Nevertheless, it will be understood that various modifications may be made without departing from the spirit and scope of the present disclosure. Accordingly, other embodiments are within the scope of the following claims.

1. A method for nondestructive testing of structures comprising:

causing an ultrasonic wave to traverse a portion of a structure being tested for presence of defects, to cause surface displacements in the structure;

providing one or more optical waveguides attached to a flexible structure, each optical waveguide comprising one or more spaced apart transducers adapted to respond to the surface displacements;

locating the one or more transducers in mechanical contact with the surface of the structure under test for a transducer response corresponding to the surface displacements of the structure at respective locations of the transducers caused by the ultrasonic wave;

obtaining modulation of the one or more transducers in response to the surface displacements of the structure; based on the response of the one or more transducers, reconstructing distribution characteristics of the ultrasonic waves across the structure; and

based on the reconstructed distribution characteristics, determining likely locations of features in the structure.

2. The method of claim 1, wherein the structure is a composite structure.

3. The method of claim 1, wherein the one or more optical waveguides are a plurality of optical waveguides configured as an array.

4. The method of claim 1, wherein the one or more optical waveguides are a single waveguide including one or more transducers.

5. The method of claim 4, wherein the one or more transducers are configured as an array.

6. The method of claim 3, wherein the optical waveguides are attached to the flexible structure in a selected array formation whereby the transducers are located at identified spaced apart positions relative to the array formation to define a matrix of the transducers.

7. The method of claim 6, wherein the selected array formation comprises a first plurality of optical waveguides in parallel along a first direction and a second plurality of optical waveguides in parallel along a second direction crossing the first plurality of optical waveguides.

8. The method of claim 1, wherein the transducers are fiber Bragg gratings (FBGs), adapted to respond in strain and/or bending to the surface displacement.

9. The method of claim 1, wherein the flexible structure comprises a flexible polymer panel.

10. The method of claim 1, wherein separate determinations are made by subsequently locating the flexible structure on different sections of the structure being tested.

11. The method of claim 1, further comprising embedding the flexible structure and the surface of the structure under test in a cover.

12. The method of claim 11, wherein the cover is a flexible cover.

13. The method of claim 11, further comprising providing an inflatable member inside the cover.

14. The method of claim 1, wherein the features are damages.

15. The method of claim 1, wherein the flexible structure is chosen from a sheet, a panel or a net.

16. The method of claim 1, wherein the one or more transducers are acoustically coupled through friction with the surface of the structure under test.

17. A nondestructive evaluation apparatus for use in responding to surface displacements caused by ultrasonic waves on a surface of a material or structure under test, the apparatus comprising:

a flexible structure having attached thereto at least one optical waveguide, each optical waveguide comprising at least one acoustic-optical transducer,

wherein the flexible structure is adapted to follow the surface displacements in strain and/or bending such that modulation of the at least one acousto-optical transducer is communicated through the optical waveguide to enable processing to determine information on the surface displacement.

18. The nondestructive evaluation apparatus of claim 17, wherein the at least one acoustic-optical transducer is at least one FBG.

19. The nondestructive evaluation apparatus of claim 17, wherein the flexible structure further comprises suction pockets to increase, during operation of the apparatus, mechanical coupling between the nondestructive evaluation apparatus and the material or structure under test through creation of underpressure between the flexible structure and the material or structure under test.

20. The nondestructive evaluation apparatus of claim 17, further comprising at least one suction cup coupled with the flexible structure to increase, during operation of the apparatus, mechanical coupling between the nondestructive evaluation apparatus and the material or structure under test through formation of underpressure under the suction cup.

21. The nondestructive evaluation apparatus of claim 20, further comprising compressible foam between the at least one suction cup and the flexible structure.

22. The nondestructive evaluation apparatus of claim 17, further comprising one or more magnets located on the apparatus when coupled to the material or structure under test.

23. A nondestructive evaluation system for evaluating a material or structure, comprising:

a source for establishing ultrasonic waves in a material or structure and which is able to be located at a selected place in the component; and

the nondestructive evaluation apparatus of claim 17, coupled to the source.

24. The nondestructive evaluation system of claim 23, wherein the source is a piezoelectric (PZT) transducer.

25. The nondestructive evaluation system of claim 23, further comprising a readout circuitry to process optical signals output by the at least one acousto-optical transducer.

26. An apparatus for determining locations of delaminations and/or disbonds in a composite piece part, comprising: an acoustic source for generating, during operation of the apparatus, ultrasonic waves in the composite piece part; and

a compliant planar member connected with the acoustic source and adapted for conforming to at least a portion of the composite piece part, the compliant planar member comprising one or more optical waveguide tracks located on a surface thereof, the one or more optical waveguide tracks comprising at least one FBG acoustically coupled to the acoustic source, the at least one FBG acting, during operation of the apparatus, as an acousto-optical transducer of acoustic signals generated by the acoustic source, the at least one FBG located at a predetermined distance from the acoustic source.

27. The apparatus of claim 26, wherein the acoustic source is a PZT transducer.

28. The apparatus of claim 26, wherein the compliant planar member is chosen from a flexible sheet, a panel, or a net.

29. The apparatus of claim 28, wherein the flexible sheet, panel or net is a flexible polymer sheet, panel or net.

30. The apparatus of claim 26, wherein the at least one FBG are a plurality of FBGs, each corresponding to a different wavelength.

31. The apparatus of claim 26, wherein the one or more optical waveguide tracks are coupled to a processor, the processor being operative to reconstruct distribution characteristics of the ultrasonic waves as transduced and reflected by the at least one FBG.

32. The apparatus of claim 26, wherein the compliant planar member comprises rigid sections interleaved with flexible sections.

33. The apparatus of claim 32, wherein the at least one FBG is located in correspondence of the rigid sections.

34. An apparatus comprising a dimensionally stable, conformable member having a first and at least one second location separated by a known distance, wherein a source of ultrasonic energy is located at the first location and at least one acousto-optical transducer is located at the at least one second location, the source being adapted to be acoustically coupled to the at least one optical transducer by placement of the conformable member on a device under test.

35. The apparatus of claim 34, wherein the at least one second location is a plurality of second locations in a pattern of known distances from the first location, each second location including an optical transducer.

36. The apparatus of claim 35, wherein the plurality of second locations comprises locations organized in different groups, each group comprising locations of like distances from the first location.

37. The apparatus of claim 34, wherein the at least one optical transducer comprises a respective at least one Bragg grating.

38. The apparatus of claim 35, wherein each optical transducer comprises a Bragg grating, the Bragg gratings being defined in at least one optical waveguide, the at least one optical waveguide being energy coupled to a sensor of reflected optical energy.

39. The apparatus of claim 38, wherein each of the Bragg gratings is operative to reflect light energy at a different wavelength.

40. A method to determine dynamic strain and/or bending of one or more optical filters, comprising:

performing a first sweeping of a tunable laser to acquire reflection or transmission spectra of the one or more optical filters;

for each optical filter, determining one or more features of the reflection or transmission spectrum of that optical filter; and

performing a second sweeping of the tunable laser to acquire acousto-ultrasound responses of the one or more optical filters.

41. The method of claim 40, wherein the optical filters are fiber Bragg gratings (FBGs).

42. The method of claim 41, wherein the one or more features of the reflection spectrum are one or both of the wavelengths substantially at half-peak intensity.

43. The method of claim 40, further comprising storing the calculated feature of the reflection or transmission spectrum.

44. The method of claim 40, wherein the first sweeping is a continuous sweeping, and the second sweeping is a non-continuous sweeping.

45. The method of claim 44, wherein during the second sweeping a stop at the calculated feature of each optical filter is made for a sufficient time to acquire the acousto-ultrasound response of the optical filter.

46. The method of claim 40, wherein the optical filters are Fabry-Perot cavities.

* * * * *