

No. 737,758.

PATENTED SEPT. 1, 1903.

W. R. MILLER.
CUTTING AND TRIMMING MACHINE.

APPLICATION FILED JUNE 17, 1901.

NO MODEL.

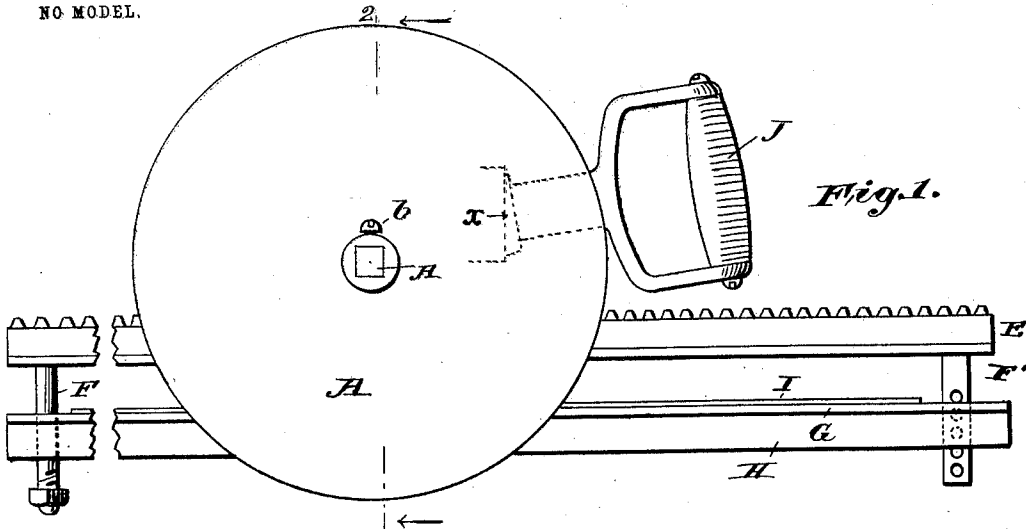

Fig. 1.

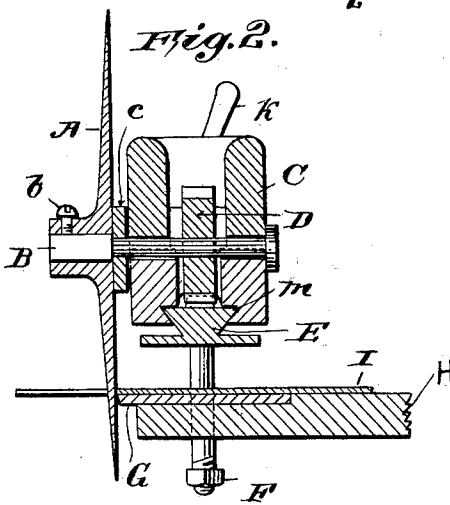

Fig. 2.

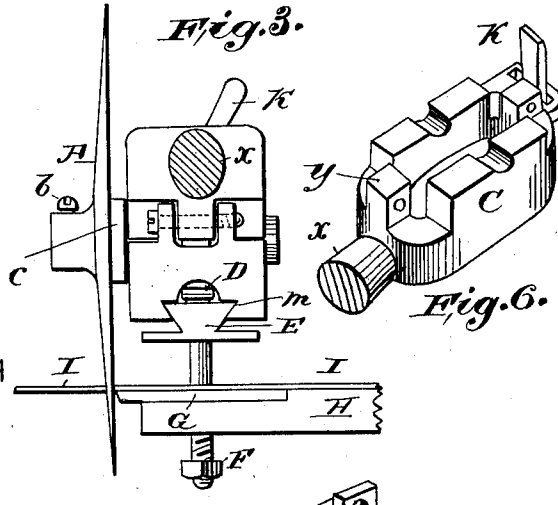

Fig. 3.

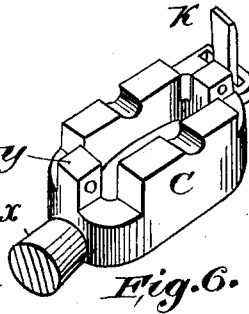

Fig. 6.

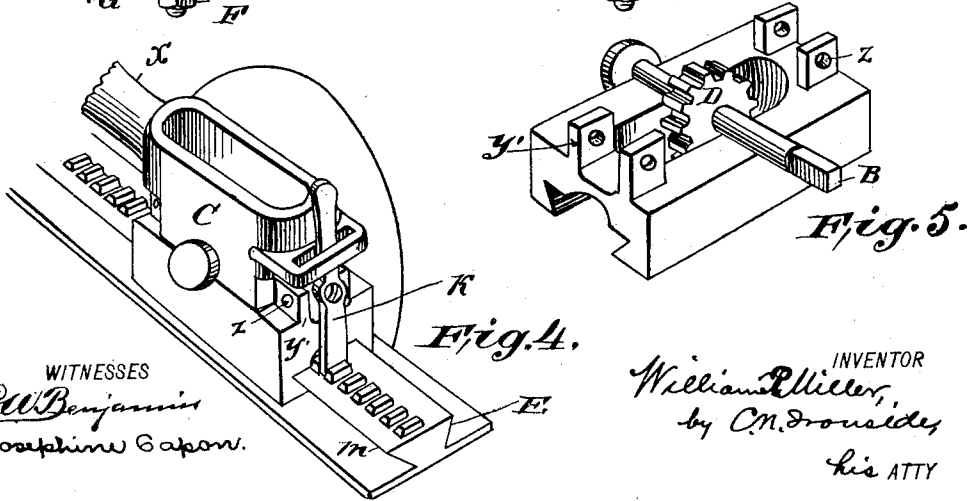

Fig. 4.

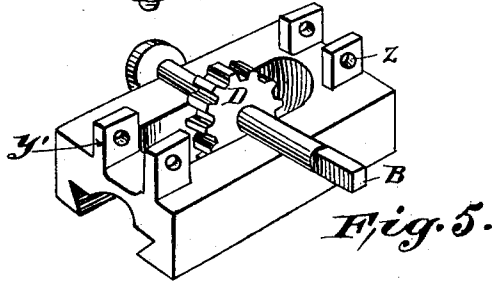

Fig. 5.

WITNESSES
Ed Benjamin
Josephine Gapon.

INVENTOR
William Miller,
 by *C. M. Drouais*
 his ATTY

UNITED STATES PATENT OFFICE.

WILLIAM R. MILLER, OF NEW YORK, N. Y.

CUTTING AND TRIMMING MACHINE.

SPECIFICATION forming part of Letters Patent No. 737,758, dated September 1, 1903.

Application filed June 17, 1901. Serial No. 64,834. (No model.)

To all whom it may concern:

Be it known that I, WILLIAM R. MILLER, a citizen of the United States, residing in the city, county, and State of New York, have invented certain new and useful Improvements in Cutting and Trimming Machines, of which the following is a specification.

My invention relates to certain improvements in cutting and trimming machines particularly designed for cutting and trimming wall-paper and the like. The principal object of my invention is to produce a machine for this purpose which can be used on any ordinary table and which will operate to cut or trim with mathematical accuracy at any desired angle.

In carrying my invention into practical effect I employ a straight-edge having mounted thereon a rack-bar or gear-plate. This straight-edge and rack-bar by means of suitable thumb-screws or other attachments can be mounted upon and secured to any ordinary table or other suitable support. The cutting mechanism comprises a rotary knife circular in form and mounted upon an axle having fixed thereon a cog-wheel arranged and adjusted to mesh with the teeth of the rack-bar or gear-plate. This axle is housed in a box adjusted to slide on the straight-edge when power is applied by manipulation of a hand-lever, by means of which the cog-wheel operating the knife is forced in mesh with the rack-bar, and thus rotates the axle upon which the knife is fixed. By this simple mechanism I am able to cut wall-paper or the like accurately at any desired angle, and the machine can be readily attached to and used upon any ordinary table.

In the accompanying drawings, illustrating my invention, like parts are designated by similar letters of reference.

Figure 1 is a side view of the entire machine in operation. Fig. 2 is a sectional view of the machine as it appears in operation. Fig. 3 is an end elevation of the said machine. Fig. 4 is a top view of the machine as it appears in operation. Fig. 5 is a top view of the gear-wheel and of the lower half of the box in which it operates, and Fig. 6 is a top view of the upper half of the box in which the gear-wheel operates as it appears when lifted off the lower half of such box and inverted.

A rotary knife circular in form (marked A) is set upon a square-headed axle B and held in position by the screw *b*. The axle B extends through a washer *c* and a box C, being fastened by a bolt-head on its outer end. The axle B carries at a point about two-thirds of its length distant from its free end, upon which the circular knife is fastened, a cog or gear wheel D, (see also Fig. 5,) which operates entirely within the box C and interlocks with the teeth of a steel gear-plate E, one end of which is mounted upon a pivot-bolt F, the other end being mounted upon a flat bolt F' (see Fig. 1,) in which holes have been drilled to permit the insertion of a stop-pin, if desired.

A steel bed-plate G, having a slight inverted bevel on its outer edge, (which is mathematically straight,) is fastened by means of screws to the edge of a table or board H, the bevel edge projecting outward beyond the actual edge of the table or board such a fraction of an inch as is the thickness of the washer *c*. The bed-plate G is provided with an opening near each end corresponding with similar openings in the table or board, through which the pivot-bolt F and the flat bolt F' project below the under surface of the board or table.

The material to be cut or trimmed (lettered I in the drawings) is laid upon the table or board between the bolts F and F' (see Fig. 1) and adjusted to suit the need of the operator, so that the cutting-line will exactly correspond with the bevel edge of the bed-plate G. The steel gear-plate E is then swung on the pivot-bolt F until the flat bolt F' can be dropped into the opening prepared for it in the bed-plate G and there firmly adjusted by means of a stop-pin run through the proper hole drilled in it, so that the under surface of the gear-plate E presses upon the upper surface of the material to be cut or trimmed.

The operator by means of the handle J, which is attached to one end of the box C by means of a screw-socket *x* and is extended beyond the edge of the circular knife A to protect the hand of the operator, moves the box C, with its axle B, carrying the circular knife A and its cog or gear wheel D forward or backward at will along the gear-plate E. The application of power to the handle J im-

parts through the cog or gear wheel D and axle B a rotary motion to the circular knife A, thus causing it to perform the act of cutting.

On the end of the box opposite from the socket *x* (see Fig. 4) is placed a pivoted brake K, whose foot is so made as to lock between the teeth of the gear-plate E and hold the box, with its attendant parts, stationary at any point on the said gear-plate that may be desired by the operator.

For convenience in cleaning, carrying, or packing for shipment the box C is made in two sections, the lower one of which (see Fig. 5) carries the cog or gear wheel D and axle B and the upper one of which (see Fig. 6) carries the brake K. A projection *y* at each end of the upper section of the box C when in place for use fits into corresponding openings between the projections *y'* at each end of the lower section of the box C and is there firmly fastened by means of screws passing through the holes *z*, enabling the box, with its attendant parts, to be moved along the gear-plate E in a solid mass. The gear-plate E is made to fit, by means of bevels, into a socket on the bottom of the box C at *m*, as shown in Figs. 2, 3, 4, and 5, thus insuring steadiness and smoothness of motion and continuity of pressure and preventing any irregularity in the operation of the knife A that might arise from the "jumping" of the gear-wheel D. If desired, the flat bolt F' may be made circular in form with a screw-thread on most of its length, upon which a thumb-screw may run to take the place of a stop-pin in holding the gear-plate E firmly upon the surface of the material to be cut or trimmed.

What I claim as my invention, and desire to secure by Letters Patent, is—

1. In a cutting and trimming machine, the combination of an adjustable gear-plate, a box slidably mounted upon said plate, a shaft journaled in said box, a rotary knife keyed to the shaft, and means for imparting motion to the said shaft, substantially as described.

2. In a cutting and trimming machine, the combination of an adjustable gear-plate, a sectional box removably secured to said plate, a shaft journaled upon the box between the sections, a knife carried by said shaft, and means for rotating the same, substantially as described.

3. In a cutting and trimming machine, the combination of an adjustable gear-plate, a sectional box comprising two members, means formed upon one adapted to engage the beveled

portion of the gear-plate, a handle secured to the other member, a shaft journaled upon the two members, a rotary knife carried by said shaft, and means for rotating the said knife, substantially as described.

4. In a cutting and trimming machine, the combination of an adjustable gear-plate, a box comprising two parts slidably mounted upon said plate, a brake secured upon said box, a rotary knife carried by said box, and means for rotating the knife, substantially as described.

5. In a cutting and trimming machine, the combination of an adjustable gear-plate, a sectional box comprising two members slidably mounted upon said plate, a suitable brake secured to said box upon one member, a handle secured upon the other member, a rotary knife keyed to a shaft journaled upon the box and means for rotating said shaft, substantially as described.

6. In a cutting and trimming machine, the combination of an adjustable gear-plate, a sectional box comprising two members slidably mounted upon said plate, a socket formed upon one member for engaging the bevel of the gear-plate, projections formed integral therewith, and adapted to engage projections formed upon the other member for locking the parts together, and means for reciprocating the same, substantially as described.

7. In a cutting and trimming machine, the combination with an adjustable bed-plate of an adjustable gear-plate secured to said bed-plate by means of extensions formed integral with said gear-plate and engaging the bed-plate, a sectional box mounted upon the gear-plate, a rotary knife carried by said box, and means whereby motion may be imparted to said box and the knife, substantially as described.

8. In a cutting and trimming machine, the combination with a suitable bed-plate of an adjustable gear-plate pivotally mounted upon said bed-plate, a sectional box carried by the gear-plate comprising two parts, a shaft journaled between the parts, a rotary knife keyed to said shaft, means for securing said parts in a locked position, and means for imparting motion to the said shaft and box, substantially as described.

WILLIAM R. MILLER.

Witnesses:

JOSEPHINE CAPON,
RITA BRADT.