

(19) World Intellectual Property Organization
International Bureau



(43) International Publication Date
7 August 2003 (07.08.2003)

PCT

(10) International Publication Number
WO 03/065346 A1

(51) International Patent Classification⁷: **G10K 11/178**

(21) International Application Number: PCT/US02/37480

(22) International Filing Date:
21 November 2002 (21.11.2002)

(25) Filing Language: English

(26) Publication Language: English

(30) Priority Data:
10/060,158 30 January 2002 (30.01.2002) US

(71) Applicant: **SENSIMETRICS CORPORATION**
[US/US]; 48 Grove Street, Somerville, MA 02144 (US).

(72) Inventor: **WIEGAND, Thomas, E.**; 246 Willow Avenue,
Sommerville, MA 02144 (US).

(74) Agents: **DIENER, Michael, A.** et al.; Hale and Dorr LLP,
60 State Street, Boston, MA 02109 (US).

(81) Designated States (*national*): AE, AG, AL, AM, AT, AU, AZ, BA, BB, BG, BR, BY, BZ, CA, CH, CN, CO, CR, CU, CZ, DE, DK, DM, DZ, EC, EE, ES, FI, GB, GD, GE, GH, GM, HR, HU, ID, IL, IN, IS, JP, KE, KG, KP, KR, KZ, LC, LK, LR, LS, LT, LU, LV, MA, MD, MG, MK, MN, MW, MX, MZ, NO, NZ, OM, PH, PL, PT, RO, RU, SD, SE, SG, SI, SK, SL, TJ, TM, TN, TR, TT, TZ, UA, UG, UZ, VN, YU, ZA, ZM, ZW.

(84) Designated States (*regional*): ARIPO patent (GH, GM, KE, LS, MW, MZ, SD, SL, SZ, TZ, UG, ZM, ZW), Eurasian patent (AM, AZ, BY, KG, KZ, MD, RU, TJ, TM), European patent (AT, BE, BG, CH, CY, CZ, DE, DK, EE, ES, FI, FR, GB, GR, IE, IT, LU, MC, NL, PT, SE, SK, TR), OAPI patent (BF, BJ, CF, CG, CI, CM, GA, GN, GQ, GW, ML, MR, NE, SN, TD, TG).

Published:
— with international search report

For two-letter codes and other abbreviations, refer to the "Guidance Notes on Codes and Abbreviations" appearing at the beginning of each regular issue of the PCT Gazette.

(54) Title: OPTICAL SIGNAL TRANSMISSION BETWEEN A HEARING PROTECTOR MUFF AND AN EAR-PLUG RECEIVER

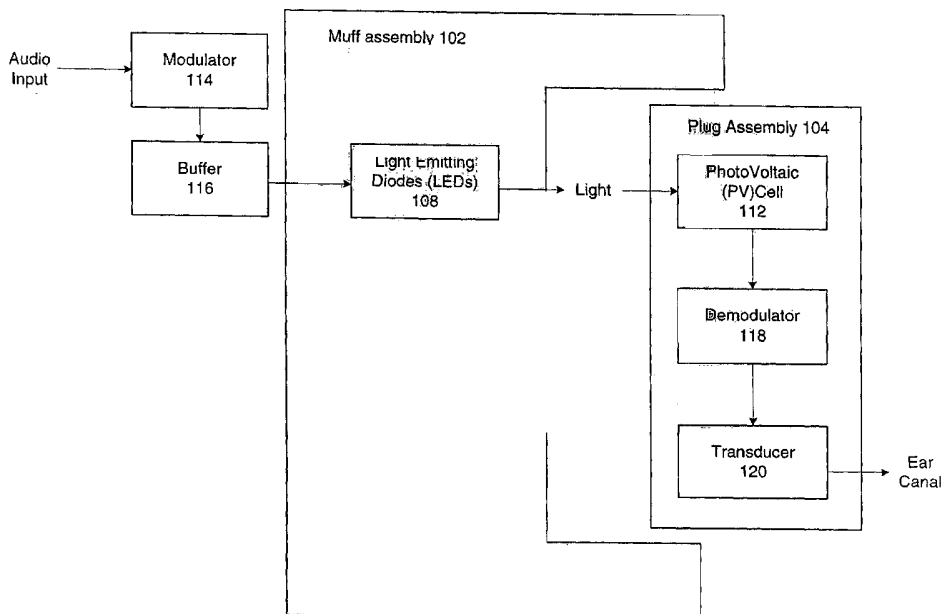

(57) Abstract: A hearing protector assembly has a muff and an ear-plug for hearing protection while allowing reception of audio communication. The muff has a receiver for audio signals, a modulation circuit, and a set of LEDs for transmitting the audio signal as a light signal. The ear-plug has a photovoltaic cell for receiving the light signals, a demodulator circuit, and a transducer for converting the received signal into an acoustic signal.



WO 03/065346 A1

OPTICAL SIGNAL TRANSMISSION BETWEEN A HEARING PROTECTOR MUFF AND AN EAR-PLUG RECEIVER

BACKGROUND OF THE INVENTION

5 The present invention pertains to hearing protectors.

Hearing protectors are designed to prevent external sound from reaching the ears. They are used in a variety of situations, and are used, for example, by people who are exposed to high levels of noise for extended periods of time. They can also be used during hearing testing, in which case they are used to
10 reduce the interfering effects of background noise in a test environment.

The two most common forms of hearing protectors are muffs and ear-plugs, which can be used separately or together for maximal sound attenuation. In many situations, it is desirable for users of hearing protectors (such as helicopter pilots) to continue to receive audio communications while blocking
15 harmful sounds. Some types of muff-type protectors are therefore equipped with earphones to form a communication headset. If both ear-plugs and muffs are needed but the user must also receive audio signals, a communication headset does not serve the purpose because acoustic signals are attenuated by the plugs before they reach the user's ears.

20

SUMMARY OF INVENTION

The invention relates to hearing protectors and to methods for providing acoustic signals to users wearing hearing protectors. Described embodiments include an apparatus and method that use optical signal transmission between a
25 signal transmitter in a hearing protecting muff and a receiver connected to an ear-plug and inserted into the ear canal.

The embodiments of the present invention can include at least some of the following benefits: the circuitry in the ear-plug requires no battery and can operate at low power levels; optical transmissions are easily contained within the
30 muff and therefore do not pose a risk of interfering with other systems; and an optical receiver can be made immune to interference from external electromagnetic fields. The method of transmission used in the present invention

is simple and efficient. The light can be transmitted with light emitting diodes (LEDs) powered by a simple battery and therefore provide many hours of use. Other features and advantages will become apparent from the following detailed description, drawings, and claims.

5

BRIEF DESCRIPTION OF THE DRAWINGS

Fig. 1 is a pictorial representation of an embodiment of the assembly of the invention.

Fig. 2 is a block diagram according to an embodiment of the invention.

10

Fig. 3 is a schematic of a circuit according to an embodiment of the invention.

DETAILED DESCRIPTION

15

Fig. 1 shows a pictorial view of a hearing protection system 100 which includes a muff assembly 102 and ear-plug assembly 104. Muff assembly 102 includes a sound-isolating muff 106 and LEDs 108. Muff 106 has a simple shell and may have a custom fit enclosure or active noise cancellation circuitry (not shown). Muff 106 is worn over a user's ear. Ear-plug assembly 104 includes plug 110, a mono-crystalline silicon photovoltaic (PV) cell 112, and circuitry. Plug 20
110 can be made of any suitable compliant material in a generic shape or can be a custom-cast earmold for improved fit and sealing ability. Plug 110 is inserted into the user's ear canal, while PV cell 112 is outside the ear canal.

25

Referring also to Fig. 2, an external audio input is provided to modulator 114 for modulating the signal, and then to a buffer 116. The buffered signal drives a light source, such as LEDs 108, to emit light signals representative of the audio input. Plug assembly 104 has a PV cell 112 that is positioned to receive the light signals from LEDs 108. PV cell 112 receives the light signals from LEDs 108 and passes them to a demodulator 118 and a miniature loudspeaker transducer 120 to provide to the user an audio output that is representative of the 30
audio input. Demodulator 118 and transducer 120 are thus part of plug assembly 104.

Fig. 3 shows an example of a schematic of circuits 130 and 128 that correspond to circuits shown in block form in Fig. 2. An audio input signal is provided to a modulator 114, such as a pulse width modulator (PWM). The PWM includes an input circuit consisting of a high pass filter and load, formed by capacitor 148 and resistor 150, a comparator 134, and an oscillator 132. The filtered input is provided to the inverting input of comparator 134. The non-inverting input to comparator 134 is a 30 kHz triangle wave carrier signal generated by oscillator 132.

Muff assembly 102 may physically include modulator 114 and buffer 116, or may be physically remote from them. Unless otherwise indicated, these circuit components are considered part of the muff assembly even if physically remote.

The modulated audio signal is provided to buffer 116, which is formed in this example by a transistor 136 and a low-output resistor. Transistor 116 has one side coupled to ground, the other side coupled to one side of LEDs 108, and a control lead coupled to the output of comparator 134. A power source 138, such as a 9-volt battery, is coupled to the other side of LEDs 108. As transistor 136 turns on and off in response to the comparator, light output of LEDs 108 follows.

As shown in Fig. 3, ear-plug circuit 128 includes a parallel connection of PV cell 112, a load resistor 140, and capacitor 142. Load resistor 140 and capacitor 142 form a low pass filter that serves as demodulator 118 of Fig. 2, and are in parallel with a series coupling capacitor 144 and a low impedance hearing aid transducer 146.

With low impedance, transducer 146 effectively utilizes the power received from PV cell 112. The impedance is preferably on the order of 50 ohms rather than a more common 500 ohm. The demodulation/filtering that occurs in circuit 128 is determined partly by the discrete capacitor and resistor components and partly by the intrinsic characteristics of the PV cell (internal resistance, capacitance) and acoustic transducer (resistance, inductance, acoustical parameters). Using the component values specified to drive an acoustic circuit

replicating a human ear canal, one can achieve 90dB SPL and distortion levels under 1%.

Circuitry 128 of PV cell 112 is compact enough to be enclosed in the space between muff 106 and the wearer's ear without adversely affecting the fit
5 or effectiveness of muff 106. The ear plus circuitry can be provided, for example, on the back of the PV cell using surface mount technology, or combined with the PV cell in a three-dimensional circuit board.

Due to propagation characteristics inherent in optical transmission, the present invention is immune to interference from adjacent transmitters and does
10 not cause interference for other apparatus. This feature is useful because it allows for binaural presentation (i.e. two independent channels, one for each ear), and also eliminates interaction between any one system and neighboring systems.

For binaural presentation over separate channels, each muff would have
15 its own modulator and buffer, although it would be preferable to share the oscillator and power supply. A monaural system provided to both ears would share one modulator and buffer, but have separate LEDs and ear-plug assemblies.

Other embodiments of the present invention are within the claims. For
20 example, the light used in transmission can be visible or infrared, with red being particularly useful for demonstration purposes. While LEDs have been used as an exemplary light source, other sources could be used, preferably a source that is capable of being modulated at an adequately high frequency to accommodate the modulation scheme. While one photocell per ear-plug assembly is preferred,
25 a stack of photocells can be used. The cells can be rectangular in shape or shaped to conform to the ear. Other forms of modulation, such as pulse density and frequency modulation, can be used as an alternative to pulse width modulation. The frequency of the carrier waveform used for modulation can be different from the 30 kHz shown, but should be above the Nyquist frequency of
30 15 kHz and not be too high to create loss from capacitive effects in the PV cell.

What is claimed is:

CLAIMS

1. A combination hearing protector/communication system assembly that attenuates undesired external sounds and delivers audio to the user,
5 comprising:

a first hearing protecting muff for attenuating sounds and receiving desired acoustic signals, the muff enclosing an optical transmitter for transmitting optical signals representative of the received acoustic signals; and

an ear-plug assembly including an optical receiver for receiving the
10 transmitted optical signals and a transducer for providing acoustic signals representative of the acoustic signals received by the muff.

2. The assembly of claim 1, wherein the optical transmitter includes one or more light emitting diodes (LEDs).
15

3. The assembly of claim 2, wherein the muff receives modulated acoustic signals from a remote modulator and provides the signals to the LEDs.

4. The assembly of claim 2, wherein the muff incorporates a modulator
20 for providing modulated acoustic signals to the LEDs.

5. The assembly of claim 1, wherein the optical receiver includes a photovoltaic cell.

25 6. The assembly of claim 5, wherein the ear-plug assembly includes a demodulator and a transducer, the photovoltaic cell providing signals to the demodulator, which provides demodulated signals to the transducer.

7. The assembly of claim 1, further comprising a second muff and a second ear-plug, each substantially the same as the first.

8. The assembly of claim 7, wherein the first and second muffs receive
5 and provide signals over separate channels.

9. The assembly of claim 8, wherein each muff has separate modulator and buffer circuits.

10. The assembly of claim 9, wherein the circuits for the muffs share
10 use of an oscillator.

11. A method for providing hearing protection and desired audio signals, comprising:

15 a hearing protecting muff receiving an audio signal;
converting the audio signal to a light signal;
transmitting the light signal from the muff to the ear-plug;
an ear-plug with a detector receiving the light signals;
converting the optical signal to an acoustic signal.

20

12. The method of claim 11, wherein the transmitting includes transmitting one of visible or infrared light.

13. The method of claim 11, wherein the converting processes include
25 pulse width modulation and demodulation.

14. The method of claim 11, further comprising receiving an audio signal with a second muff, and transmitting a light signal to a second ear-plug over a separate channel.

5 15. A hearing protection system including a muff and an ear-plug, with optical communication therebetween.

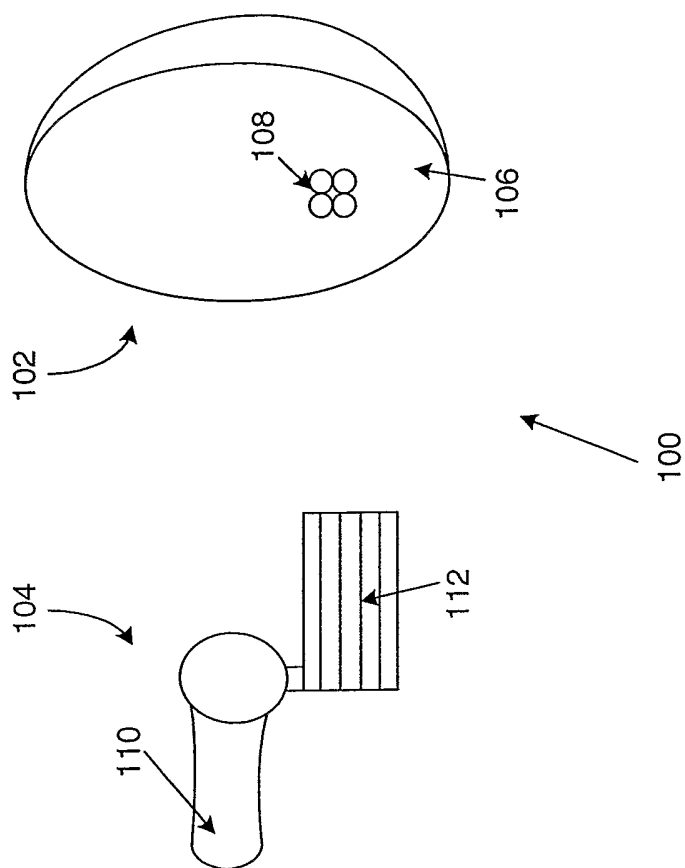

Fig. 1

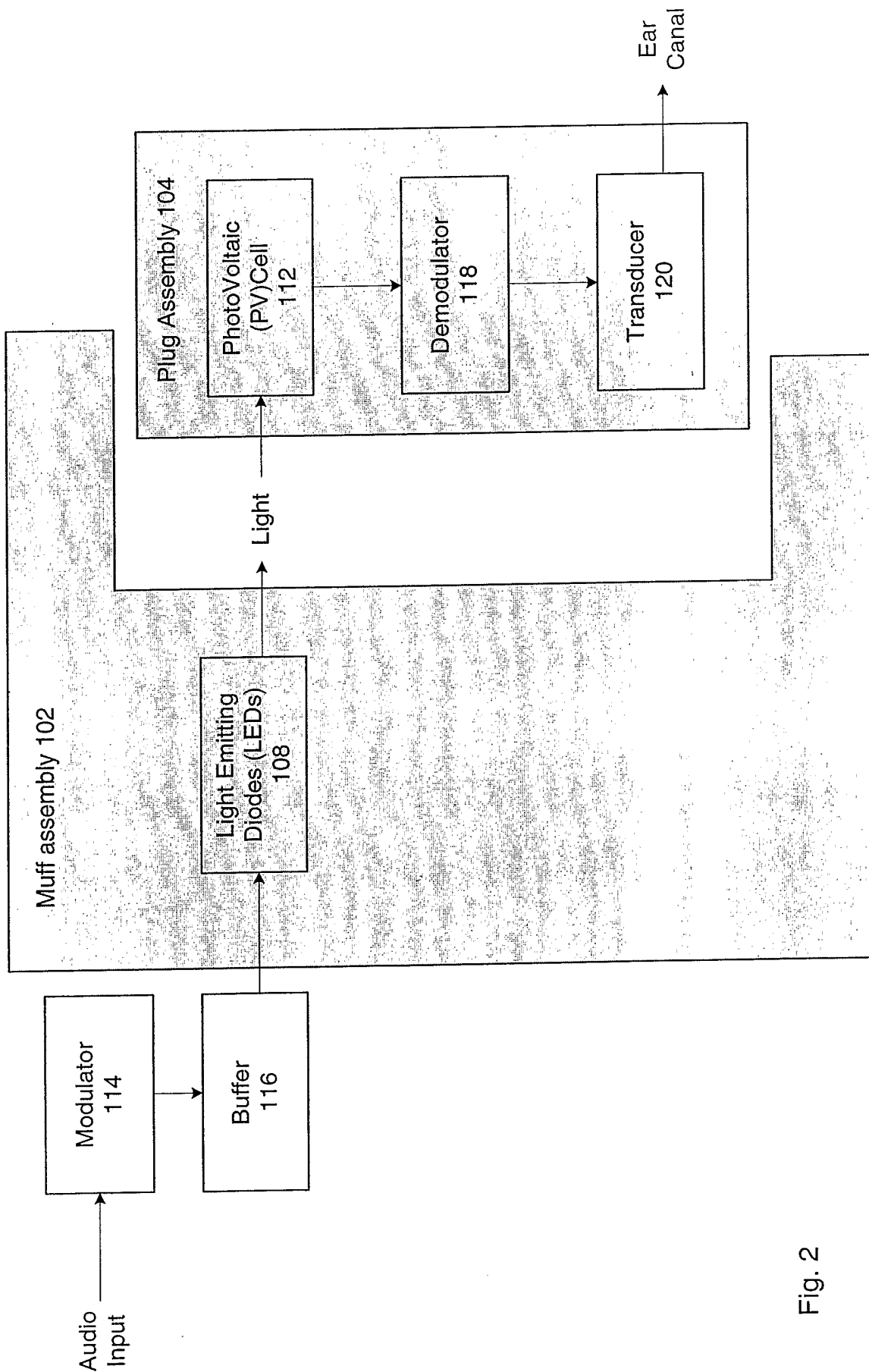

Fig. 2

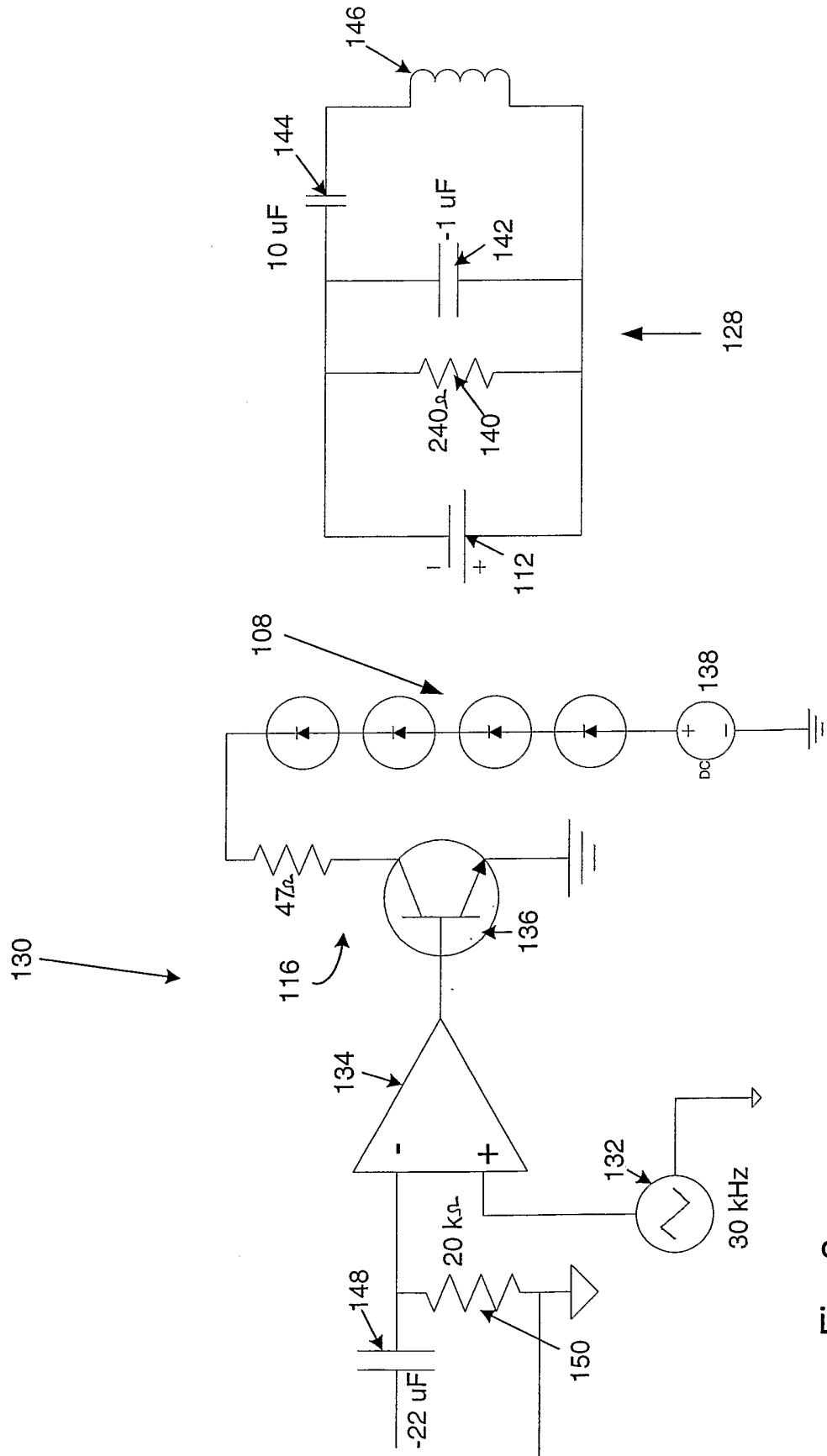

Fig. 3

INTERNATIONAL SEARCH REPORT

International Application No
PCT/US 02/37480

A. CLASSIFICATION OF SUBJECT MATTER
IPC 7 G10K11/178

According to International Patent Classification (IPC) or to both national classification and IPC

B. FIELDS SEARCHED

Minimum documentation searched (classification system followed by classification symbols)
IPC 7 G10K A61F

Documentation searched other than minimum documentation to the extent that such documents are included in the fields searched

Electronic data base consulted during the international search (name of data base and, where practical, search terms used)

EPO-Internal

C. DOCUMENTS CONSIDERED TO BE RELEVANT

Category °	Citation of document, with indication, where appropriate, of the relevant passages	Relevant to claim No.
A	DE 101 17 705 A (HOERGERAETE KIND GMBH U CO KG) 31 October 2001 (2001-10-31) column 2, line 44 - line 56 column 3, line 51 -column 4, line 8 ---	1, 3, 5, 7, 11, 12, 14, 15
A	WO 00 45760 A (WILD LARS) 10 August 2000 (2000-08-10) page 12, line 4 - line 17 page 13, line 4 - line 5; claims 1,2 ---	1, 3, 5-8, 11, 12, 14, 15
A	US 5 295 191 A (VAN VROENHOVEN PETRUS A W H) 15 March 1994 (1994-03-15) column 1, line 51 - line 65 ---	1, 3, 5, 11, 12, 14, 15
	-/--	

Further documents are listed in the continuation of box C.

Patent family members are listed in annex.

° Special categories of cited documents :

- *A* document defining the general state of the art which is not considered to be of particular relevance
- *E* earlier document but published on or after the international filing date
- *L* document which may throw doubts on priority claim(s) or which is cited to establish the publication date of another citation or other special reason (as specified)
- *O* document referring to an oral disclosure, use, exhibition or other means
- *P* document published prior to the international filing date but later than the priority date claimed

- *T* later document published after the international filing date or priority date and not in conflict with the application but cited to understand the principle or theory underlying the invention
- *X* document of particular relevance; the claimed invention cannot be considered novel or cannot be considered to involve an inventive step when the document is taken alone
- *Y* document of particular relevance; the claimed invention cannot be considered to involve an inventive step when the document is combined with one or more other such documents, such combination being obvious to a person skilled in the art.
- * & * document member of the same patent family

Date of the actual completion of the international search

19 March 2003

Date of mailing of the international search report

26/03/2003

Name and mailing address of the ISA
European Patent Office, P.B. 5818 Patentlaan 2
NL - 2280 HV Rijswijk
Tel. (+31-70) 340-2040, Tx. 31 651 epo nl,
Fax: (+31-70) 340-3016

Authorized officer

Swartjes, H

INTERNATIONAL SEARCH REPORT

International Application No
PCT/US 02/37480

C.(Continuation) DOCUMENTS CONSIDERED TO BE RELEVANT

Category *	Citation of document, with indication, where appropriate, of the relevant passages	Relevant to claim No.
A	DE 35 08 830 A (BOSCH GMBH ROBERT) 18 September 1986 (1986-09-18) ---	
A	US 5 768 397 A (FAZIO JOSEPH D) 16 June 1998 (1998-06-16) -----	

INTERNATIONAL SEARCH REPORT

Information on patent family members

International Application No

PCT/US 02/37480

Patent document cited in search report		Publication date	Patent family member(s)	Publication date
DE 10117705	A	31-10-2001	DE 10117705 A1	31-10-2001
WO 0045760	A	10-08-2000	DE 29902617 U1	20-05-1999
			AU 3144400 A	25-08-2000
			WO 0045760 A1	10-08-2000
			DE 10080188 D2	24-01-2002
			EP 1150633 A1	07-11-2001
US 5295191	A	15-03-1994	AT 127647 T	15-09-1995
			DE 69204555 D1	12-10-1995
			DK 517323 T3	18-12-1995
			EP 0517323 A2	09-12-1992
			JP 3121678 B2	09-01-2001
			JP 5176398 A	13-07-1993
DE 3508830	A	18-09-1986	DE 3508830 A1	18-09-1986
			CH 668341 A5	15-12-1988
			DK 102086 A	14-09-1986
			JP 61213000 A	20-09-1986
US 5768397	A	16-06-1998	AU 3900697 A	06-03-1998
			WO 9808333 A1	26-02-1998