

Sept. 24, 1940.

L. J. PELLERIN

2,215,836

FILLING STAND

Filed Dec. 7, 1939

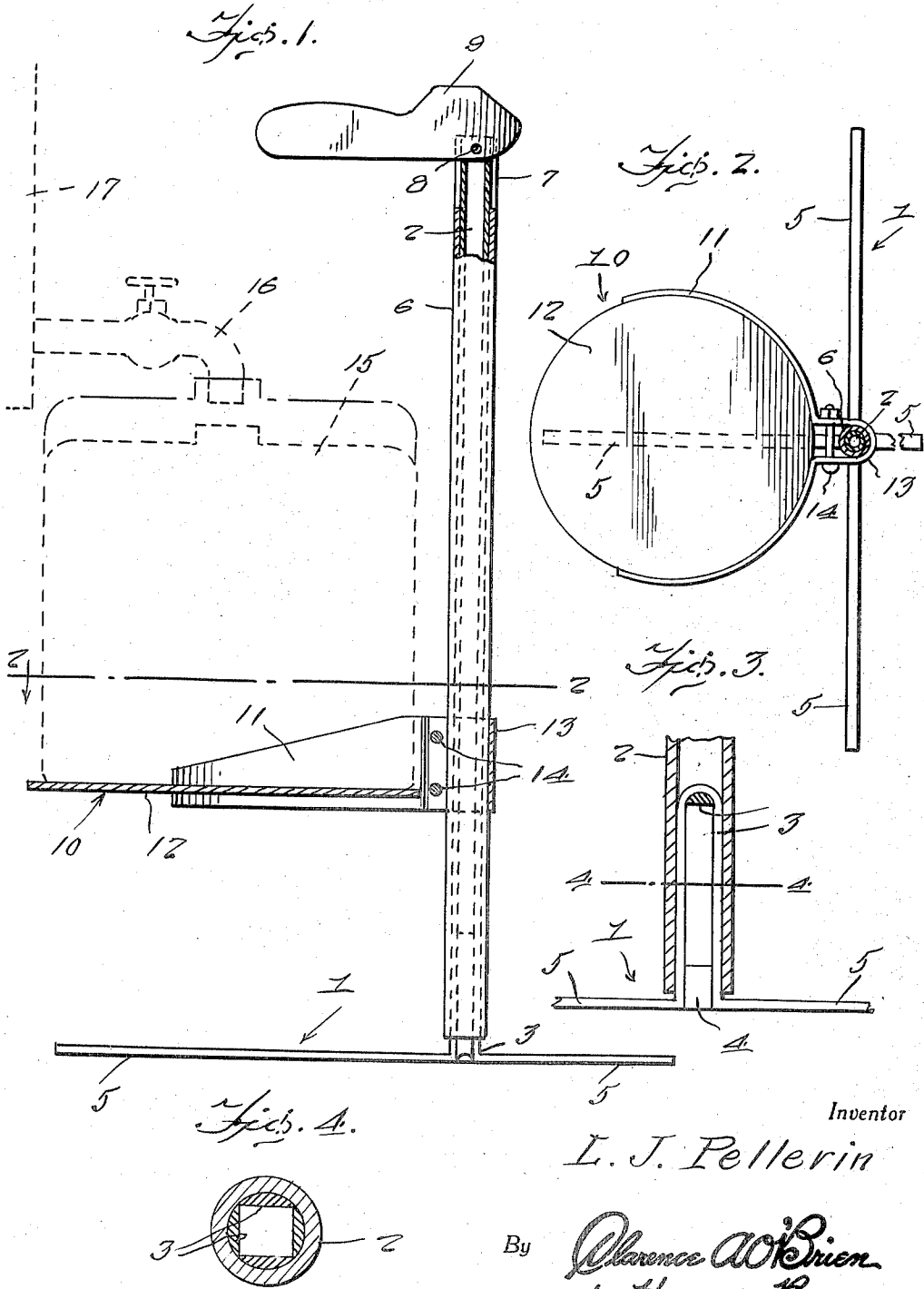

Inventor

L. J. Pellerin

By *Clarence W. O'Brien*  
*and Hyman Berman*  
Attorneys

# UNITED STATES PATENT OFFICE

2,215,836

## FILLING STAND

Lionel J. Pellerin, Lynn, Mass.

Application December 7, 1939, Serial No. 308,098

3 Claims. (Cl. 254—114)

The present invention relates to new and useful improvements in filling stands particularly for filling the tanks or bottles of range oil burners from fuel drums but it will be understood, of course, that a stand constructed in accordance with the present invention may be used for any other purpose for which it may be found adapted and desirable.

The primary object of the invention is to provide, in a manner as hereinafter set forth, a stand of the aforementioned character comprising novel means through the medium of which a container, such as a fuel tank or bottle, may be expeditiously elevated and supported with a minimum of effort beneath the spigot of a fuel barrel or drum in a manner to prevent spilling of the fuel.

Another very important object of the invention is to provide a filling stand of the character described which may be conveniently adjusted as desired to meet various conditions.

Other objects of the invention are to provide a filling stand of the character set forth which will be comparatively simple in construction, strong, durable, highly efficient and reliable in use, compact, light in weight and which may be manufactured at low cost.

All of the foregoing and still further objects and advantages of the invention will become apparent from a study of the following specification, taken in connection with the accompanying drawing wherein like characters of reference designate corresponding parts throughout the several views, and wherein:

Figure 1 is a view in side elevation of an embodiment of the device, portions thereof being shown in vertical section.

Figure 2 is a view in horizontal section, taken substantially on the line 2—2 of Figure 1.

Figure 3 is a view in vertical section through the lower portion of the device, the sleeve being omitted.

Figure 4 is a view in horizontal section, taken substantially on the line 4—4 of Figure 3.

Referring now to the drawing in detail, it will be seen that the reference numeral 1 designates a base. Rising from the base 1 is a tubular post 2 of metal or other suitable material. As illustrated to advantage in Figures 3 and 4 of the drawing, the base 1 includes a pair of substantially U-shaped bars 3 of segmental cross section engaged in the lower end portion of the tubular post 2 and frictionally secured therein through the medium of a plug 4 driven between the lower end portions of the legs of said bars.

The bars 3 terminate in horizontally projecting end portions constituting feet 5. If desired, the feet 5 may be apertured to accommodate fastening elements for securing the device to a floor or other surface.

Rotatably and slidably mounted on the tubular post 2 is a metallic sleeve 6. The upper end portion of the sleeve 6 is split in a manner to provide bifurcations 7. Journaled on a pin 8 between the bifurcations 7 is a cam lever 9 which is operatively engaged with the upper end of the post 2 for raising and lowering the sleeve 6.

Adjustably mounted on the sleeve 6 is a platform which is designated generally by the reference numeral 10. The platform 10 includes an arcuate bracket 11 of suitable metal having fixed therein a plate 12. The intermediate portion of the bracket 11 is formed to provide an outwardly extending loop 13 which accommodates the sleeve 6. Bolts 14 are adapted to draw the walls of the loop 13 together for frictionally clamping the platform 10 in adjusted position on the sleeve 6. The reference numeral 15 designates a container mounted on the platform 10. The container 15 is to receive fuel from the spigot 16 of the barrel or drum 17.

It is believed that the operation of the device will be readily apparent from a consideration of the foregoing. With the cam lever 9 in the position shown in Figure 1 of the drawing and the platform 10 out from under the spigot 16, the container 15 to be filled is placed on said platform. The platform 10 is then swung around in a horizontal plane to position the filling neck of the container 15 beneath the spigot 16. If desired, suitable stop means may be employed to arrest the swinging platform 10 at the correct place. Now, by swinging the cam lever 9 to operative position the sleeve 6 with the platform 10 are elevated on the post 2 thus raising the container 15 from the position shown in dotted lines in Figure 1 of the drawing to that illustrated in dot and dash lines, in which latter position the free end portion of the spigot 16 is engaged in the container inlet. The container 15 may now be conveniently filled. Of course, to remove the filled container the foregoing operation is substantially reversed. The adjustability of the platform 10 on the rotatably and slidably mounted sleeve 6 permits various conditions to be conveniently met, such as adapting the device to different sizes of containers.

It is believed that the many advantages of a filling stand constructed in accordance with the present invention will be readily understood and

although a preferred embodiment of the device is as illustrated and described, it is to be understood that changes in the details of construction may be resorted to which will fall within the scope of the invention as claimed.

5

What is claimed is:

1. A filling stand comprising a post, a sleeve slidably mounted on the post, means for raising and lowering said sleeve, and a platform adjustably mounted on the sleeve and adapted to hold a container to be filled, said platform including a bracket, a plate mounted on said bracket, the bracket comprising an outwardly extending loop at an intermediate point mounted  
10 on the sleeve, and means for frictionally clamping the loop on the sleeve.

2. A filling stand comprising a base, a post rising from said base, a sleeve rotatably and slidably mounted on said post, a platform  
15 mounted on said sleeve and adapted to hold a

container to be filled, and a cam lever pivotally mounted on the sleeve and operatively engaged with the post for raising and lowering the sleeve, said cam lever further constituting means for rotating the sleeve on the post.

5

3. A filling stand comprising a tubular post, a base mounted on the lower end of the post, said base including a pair of substantially U-shaped bars of segmental cross section mounted in the lower end portion of the post, feet projecting horizontally from the ends of said substantially U-shaped bars, and a plug driven between the legs of the substantially U-shaped bars for frictionally securing said bars in the tubular  
10 post, a sleeve slidably mounted on the post, a platform mounted on said sleeve and adapted to hold a container to be filled, and means for raising and lowering the sleeve.

10

15

20

LIONEL J. PELLERIN.