

(19) World Intellectual Property Organization
International Bureau



(43) International Publication Date
22 June 2006 (22.06.2006)

PCT

(10) International Publication Number
WO 2006/064334 A1

- (51) International Patent Classification:
G02B 27/01 (2006.01)
- (21) International Application Number:
PCT/IB2005/003749
- (22) International Filing Date:
12 December 2005 (12.12.2005)
- (25) Filing Language: English
- (26) Publication Language: English
- (30) Priority Data:
11/011,481 13 December 2004 (13.12.2004) US
11/202,653 11 August 2005 (11.08.2005) US
- (71) Applicant (for all designated States except US): NOKIA CORPORATION [FI/FI]; Keilalahdentie 4, FIN-02150 ESPOO (FI).
- (71) Applicant (for LC only): NOKIA INC. [US/US]; 6000 Connection Drive, Irving, TX 75039 (US).
- (72) Inventor; and
- (75) Inventor/Applicant (for US only): LEVOLA, Tapani [FI/FI]; Hyhkynkatu 7 A 1, FIN-33270 Tampere (FI).
- (74) Agent: MAGUIRE, Francis, J.; Ware, Fressola, Van Der Sluys & Adolphson LLP, 755 Main Street, P.O. Box 224, Monroe, CT 06468 (US).
- (81) Designated States (unless otherwise indicated, for every kind of national protection available): AE, AG, AL, AM, AT, AU, AZ, BA, BB, BG, BR, BW, BY, BZ, CA, CH, CN, CO, CR, CU, CZ, DE, DK, DM, DZ, EC, EE, EG, ES, FI, GB, GD, GE, GH, GM, HR, HU, ID, IL, IN, IS, JP, KE, KG, KM, KN, KP, KR, KZ, LC, LK, LR, LS, LT, LU, LV, LY, MA, MD, MG, MK, MN, MW, MX, MZ, NA, NG, NI, NO, NZ, OM, PG, PH, PL, PT, RO, RU, SC, SD, SE, SG, SK, SL, SM, SY, TJ, TM, TN, TR, TT, TZ, UA, UG, US, UZ, VC, VN, YU, ZA, ZM, ZW.
- (84) Designated States (unless otherwise indicated, for every kind of regional protection available): ARIPO (BW, GH, GM, KE, LS, MW, MZ, NA, SD, SL, SZ, TZ, UG, ZM, ZW), Eurasian (AM, AZ, BY, KG, KZ, MD, RU, TJ, TM), European (AT, BE, BG, CH, CY, CZ, DE, DK, EE, ES, FI, FR, GB, GR, HU, IE, IS, IT, LT, LU, LV, MC, NL, PL, PT,

[Continued on next page]

(54) Title: GENERAL DIFFRACTIVE OPTICS METHOD FOR EXPANDING AN EXIT PUPIL

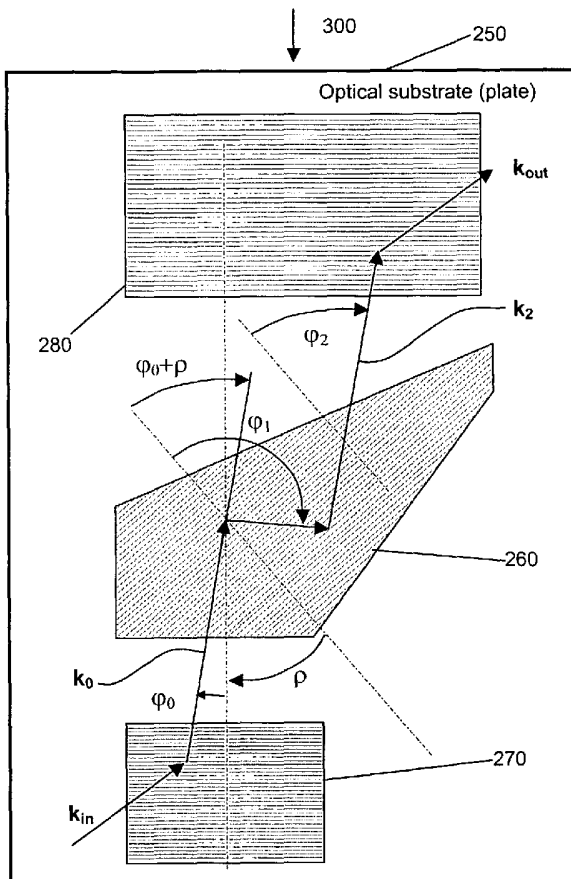

(57) Abstract: An exit pupil extender with one input optical element and two exit optical elements disposed on different sides of the input optical element. The exit pupil extender also comprises two intermediate diffractive optical couplers, each disposed between the input optical element and one exit optical element. The couplers serve as exit pupil extending components. The grating lines of the couplers are at substantially a 60-degree angle from that of the optical elements in order to optimize the exit pupil extending efficiency. This invention further describes a general diffractive optics method that uses a plurality of diffractive elements on an optical substrate for expanding the exit pupil of a display of an electronic device for viewing. The system can support a broad range of rotations angles (e.g., $0 < \rho < 70^\circ$) and corresponding conical angles and remains geometrically accurate.

WO 2006/064334 A1



RO, SE, SI, SK, TR), OAPI (BF, BJ, CF, CG, CI, CM, GA, GN, GQ, GW, ML, MR, NE, SN, TD, TG).

For two-letter codes and other abbreviations, refer to the "Guidance Notes on Codes and Abbreviations" appearing at the beginning of each regular issue of the PCT Gazette.

Published:

— *with international search report*

GENERAL DIFFRACTIVE OPTICS METHOD FOR EXPANDING
AN EXIT PUPIL

5

Priority and Cross-reference to Related Application

This application is a continuation in part of and claims priority from
U.S. Patent Application Serial No.: 11/011,481, filed on December 13, 2004 and
U.S. Patent Application Serial No.: 11/202,653, filed on August 11, 2005.

10

Technical Field

The present invention relates generally to a display device and, more specifically, to a general diffractive optics method that uses a plurality of diffractive elements for expanding the exit pupil of a display for viewing.

Background Art

15 While it is a common practice to use a low-resolution liquid-crystal display (LCD) panel to display network information and text messages in a mobile device, it is preferred to use a high-resolution display to browse rich information content of text and images. A microdisplay-based system can provide full color pixels at 50-100 lines per mm. Such high-resolution is generally suitable for a virtual display. A
20 virtual display typically consists of a microdisplay to provide an image and an optical arrangement for manipulating light emerging from the image in such a way that it is perceived as large as a direct view display panel. A virtual display can be monocular or binocular.

The size of the beam of light emerging from imaging optics toward the eye is
25 called exit pupil. In a Near-Eye Display (NED), the exit pupil is typically of the order of 10mm in diameter. Further enlarging the exit pupil makes using the virtual display significantly easier, because the device can be put at a distance from the eye. Thus, such a display no longer qualifies as an NED, for obvious reasons. Head-Up Displays are examples of the virtual display with a sufficiently large exit pupil.

PCT patent application *WO 99/52002* "Holographic optical Devices" by Yaakov Amitai and Asher Friesem and US patent US 6,580,529 Holographic optical Devices" by Yaakov Amitai and Asher Friesem disclose a method of enlarging the exit pupil of a virtual display. The disclosed method uses three successive

5 holographic optical elements (HOEs) to enlarge the exit pupil. In particular, the HOEs are diffractive grating elements arranged on a planar, light transmissive substrate **6**, as shown in Figure 1. As shown, light from an image source **2** is incident upon the first HOE, or **H1**, which is disposed on one side of the substrate **6**. Light from **H1**, coupled to the substrate **6**, is directed toward the second HOE, or **H2**, where

10 the distribution of light is expanded in one direction. **H2** also redirects the expanded light distribution to the third HOE, or **H3**, where the light distribution is further expanded in another direction. The holographic elements can be on any side of the substrate **6**. **H3** also redirects the expanded light distribution outward from the substrate surface on which **H3** is disposed. The optical system, as shown in Figure 1,

15 operates as a beam-expanding device, which approximately maintains the general direction of the light beam. Such a device is also referred to as an exit pupil expander (EPE).

In an EPE, the energy of the exit beam relative to the input beam depends upon the coupling between adjacent optical elements. As the energy output of the

20 image source is limited, it is desirable to achieve a high coupling efficiency between adjacent optical elements.

Disclosure of the Invention

It is an objective of the present invention to improve the optical coupling between two optical elements such as diffractive optical elements in an exit pupil

25 extender. This objective can be achieved by using a diffractive optical element having the grating lines are oriented in a certain direction as optical coupler disposing between the input optical element and the exit optical element. In particular, the grating lines of the optical coupler are oriented substantially at a 60-degree from the grating lines of the input and exit optical element.

30 Thus, the first aspect of the present invention provides an optical device, comprising:

a substrate of optical material having a first side and an opposing second side;

a first diffractive element disposed on the substrate for receiving a light beam;

a second diffractive element disposed on the substrate in relationship with the first diffractive element; and

5 an intermediate diffractive element disposed between the first and the second diffractive elements, wherein

at least part of the received light beam is diffracted in the first diffractive element for providing a diffracted light component to the intermediate diffractive element in an incident direction substantially within the first and second surface, and

10 at least part of the diffracted light component in the intermediate different element is coupled to the second diffractive element substantially between the first and second surfaces so as to allow at least part of the coupled diffracted light component to exit the substrate by diffraction in the second diffractive element, wherein the intermediate diffractive element has a substantially periodic pattern composed of substantially linear elements along a pattern direction for producing
15 conical diffraction.

According to the first aspect of the present invention, the intermediate diffractive element has a substantially periodic pattern composed of substantially linear elements along a pattern direction so that the incident direction of the diffracted light component provided to the intermediate different element is within an angular
20 range between 20 and 40 degrees relative to the pattern direction.

According to the first aspect of the present invention, the optical device further comprises:

a third diffractive element disposed on the substrate in relationship with the first diffractive element spaced from the second diffractive element; and

25 a further intermediate diffractive element disposed between the first and the second diffractive elements, wherein

at least part of the received light beam is diffracted in the first diffractive element for providing a diffracted light component to the further intermediate diffractive element in an incident direction within the first and second surface, and

at least part of the diffracted light component in the further intermediate different element is coupled to the third diffractive element substantially between the first and second surfaces so as to allow at least part of the coupled diffracted light component to exit the substrate by diffraction in the third diffractive element, wherein
5 the further intermediate diffractive element has a substantially periodic pattern composed of substantially linear elements along a pattern direction such that the incident direction of the diffracted light component provided to the further intermediate different element is within an angular range between 50 and 70 degrees relative to the pattern direction.

10 According to the first aspect of the present invention, the received light beam is received in the first diffractive element through the first surface and at least part of the coupled diffracted light component exits the substrate through the first surface or the second surface.

According to the first aspect of the present invention, intermediate diffractive
15 element comprises a plurality of grooves forming the period pattern.

According to the first aspect of the present invention, the first diffractive element has a period pattern composed of a plurality of linear elements along a pattern direction substantially perpendicular to the incident direction, and the second diffractive element has a period pattern composed of a plurality of linear elements
20 along a pattern direction substantially perpendicular to the incident direction.

According further to the first aspect of the invention, the light beam may be defined by a wave-vector \mathbf{k}_{in} and the first diffraction element may contain periodic lines with a period d ; the second diffractive element may contain further periodic lines with a period of d , wherein the further periodic lines are parallel to the periodic
25 lines of the first diffractive element; the intermediate diffractive element may contain still further periodic lines with the period defined by a range $0.9d/2\cos\rho$ to $1.1d/2\cos\rho$, wherein ρ is an angle between the periodic lines and the still further periodic lines; and the at least part of the coupled diffracted light component may exit the substrate by the diffraction in the second diffractive element thus providing an
30 output light beam defined by a further wave-vector \mathbf{k}_{out} having exactly the same direction as the wave-vector \mathbf{k}_{in} of the light beam. Further, the at least part of the diffracted light component may be further diffracted to a first order from the

intermediate diffraction element an even number of times before providing the at least part of the diffracted light component to the second diffractive element. Still further, the intermediate diffractive element may support only reflective zero and reflective first order diffraction modes, or an index of refraction of the substrate is $n > \lambda/d$,
 5 wherein λ is a wavelength of the input optical beam. Further still, a predetermined condition may be maintained, the condition is that a second or higher order modes are unsupported by the intermediate diffractive element, or the condition is expressed as $\sqrt{1 + 8 \cos^2 \rho} > \frac{nd}{\lambda}$, wherein n is an index of refraction of the substrate, λ is a wavelength of the input optical beam. Yet further still, ρ may be given by $0 < \rho < 70^\circ$.
 10 Yet still further, a predetermined condition may be maintained, the condition is that transmission modes are unsupported for the intermediate diffractive element, or the condition is expressed as $\lambda/d > 1$, wherein λ is a wavelength of the input optical beam. Still yet further, the first diffractive element, the second diffractive element or the intermediate diffractive element may be disposed on the first surface or on the second
 15 surface.

The second aspect of the present invention provides a method of optical coupling in an optical device, the optical device comprising:

a substrate of optical material having a first side and an opposing second side;
 a first diffractive element disposed on the substrate for receiving a light beam,
 20 wherein at least part of the received light beam is diffracted in the first diffractive element for providing a diffracted light component; and

a second diffractive element disposed on the substrate in relationship to the first diffractive element so as to allow at least part of the diffracted light component to exit the substrate substantially by diffraction in the second diffractive element. The
 25 method comprises:

disposing an intermediate diffractive element between the first and the second diffractive elements, so as to allow part of the diffracted light component to enter the intermediate diffractive element between the first and second surfaces at an incident direction, wherein the intermediate diffractive element has a substantially periodic

pattern composed of substantially linear elements along a pattern direction to produce conical diffraction.

According to the second aspect of the present invention, the intermediate diffractive element has a substantially periodic pattern composed of substantially linear elements along a pattern direction such that the incident direction of the diffracted light component is within an angular range between 20 and 40 degrees relative to the pattern direction.

According to the second aspect of the present invention, the optical device further comprises a third diffractive element disposed on the substrate in relationship to the first diffractive element spaced from the second device so as to allow at least part of the diffracted light component also to exit the substrate substantially by diffraction in the third diffractive element. The method further comprises:

disposing a further intermediate diffractive element between the first and the third diffractive elements, so as to allow part of the diffracted light component to enter the further intermediate diffractive element between the first and second surfaces at an incident direction, wherein the intermediate diffractive element has a substantially periodic pattern composed of substantially linear elements along a pattern direction such that the incident direction of the diffracted light component is within an angular range between 50 and 70 degrees relative to the pattern direction.

According to the second aspect of the present invention, the first diffractive element has a substantially period pattern composed of substantially linear elements along a first pattern direction, and the second diffractive element has a substantially period pattern composed of substantially linear elements along a second pattern direction substantially parallel to the first pattern direction.

According further to the second aspect of the invention, the light beam may be defined by a wave-vector \mathbf{k}_{in} and the first diffraction element may contain periodic lines with a period d ; the second diffractive element may contain further periodic lines with a period of d , wherein the further periodic lines are parallel to the periodic lines of the first diffractive element; the intermediate diffractive element may contain still further periodic lines with the period defined by a range $0.9d/2\cos\theta$ to

1. $1/d/2\cos\rho$, wherein ρ is an angle between the periodic lines and the still further periodic lines; and the at least part of the coupled diffracted light component may exit the substrate by the diffraction in the second diffractive element thus providing an output light beam defined by a further wave-vector \mathbf{k}_{out} having exactly the same
5 direction as the wave-vector \mathbf{k}_{in} of the light beam. Further, the at least part of the diffracted light component may be further diffracted to a first order from the intermediate diffraction element an even number of times before providing the at least part of the diffracted light component to the second diffractive element.

The third aspect of the present invention provides an electronic device
10 comprising:

a data processing unit;

an optical engine operatively connected to the data processing unit for receiving image data from the data processing unit;

a display device operatively connected to the optical engine for forming an
15 image based on the image data; and

an exit pupil extender, comprising:

a substrate of optical material having a first side and an opposing second side;

a first diffractive element disposed on the substrate for receiving a
20 light beam;

a second diffractive element disposed on the substrate in relationship with the first diffractive element; and

an intermediate diffractive element disposed between the first and the second diffractive elements, wherein

25 at least part of the received light beam is diffracted in the first diffractive element for providing a diffracted light component to the intermediate diffractive element in an incident direction substantially within the first and second surface, and

at least part of the diffracted light component in the intermediate different element is coupled to the second diffractive element substantially between the first and second surfaces so as to allow at least part of the coupled diffracted light component to exit the substrate by diffraction in the second

diffractive element, wherein the intermediate diffractive element has a substantially periodic pattern composed of substantially linear elements along a pattern direction for producing conical diffraction.

5 According to the third aspect of the present invention, the angle in the conical diffraction is between 50 and 70 degrees, and the intermediate diffractive element has a substantially periodic pattern composed of substantially linear elements along a pattern direction so that the incident direction of the diffracted light component provided to the intermediate different element is within an angular range between 20 and 40 degrees relative to the pattern direction.

10 According to the third aspect of the present invention, the optical device further comprises:

a third diffractive element disposed on the substrate in relationship with the first diffractive element spaced from the second diffractive element; and

15 a further intermediate diffractive element disposed between the first and the second diffractive elements, wherein

at least part of the received light beam is diffracted in the first diffractive element for providing a diffracted light component to the further intermediate diffractive element in an incident direction within the first and second surface, and

20 at least part of the diffracted light component in the further intermediate different element is coupled to the third diffractive element substantially between the first and second surfaces so as to allow at least part of the coupled diffracted light component to exit the substrate by diffraction in the third diffractive element, wherein the further intermediate diffractive element has a substantially periodic pattern composed of substantially linear elements along a pattern direction such that the
25 incident direction of the diffracted light component provided to the further intermediate different element is within an angular range between 50 and 70 degrees relative to the pattern direction.

30 According to the third aspect of the present invention, the electronic device can be a portable device, such as a mobile phone, personal digital assistant (PDA), communicator, portable Internet appliance, hand-held computer, digital video and still

camera, wearable computer, computer game device, specialized bring-to-the-eye product for viewing and other portable electronic devices. However, the exit pupil extender, according to the present invention, can also be used in a non-portable device, such as a gaming device, vending machine, band-o-matic, and home appliances, such as an oven, microwave oven and other appliances and other non-portable devices.

According further to the third aspect of the invention, the light beam may be defined by a wave-vector \mathbf{k}_{in} and the first diffraction element may contain periodic lines with a period d ; the second diffractive element may contain further periodic lines with a period of d , wherein the further periodic lines are parallel to the periodic lines of the first diffractive element; the intermediate diffractive element may contain still further periodic lines with the period defined by a range $0.9d/2\cos\rho$ to $1.1d/2\cos\rho$, wherein ρ is an angle between the periodic lines and the still further periodic lines; and the at least part of the coupled diffracted light component may exit the substrate by the diffraction in the second diffractive element thus providing an output light beam defined by a further wave-vector \mathbf{k}_{out} having exactly the same direction as the wave-vector \mathbf{k}_{in} of the light beam. Further, the at least part of the diffracted light component may be further diffracted to a first order from the intermediate diffraction element an even number of times before providing the at least part of the diffracted light component to the second diffractive element.

The present invention will become apparent upon reading the description taken in conjunction with Figures 2-10.

Brief Description of the Drawings

Figure 1 is a schematic representation showing a prior art exit pupil extender using three diffractive elements;

Figure 2 is a schematic representation showing a top view of an exit pupil extender, according to the present invention;

Figure 3 a schematic representation showing an isometric view of the exit pupil extender, according to the present invention;

Figure 4 is a schematic representation showing the orientation of the grating lines in the intermediate diffractive optical element, according to the present invention;

Figure 5 is a schematic representation showing another embodiment of the exit pupil extender, according to the present invention;

Figure 6 is a schematic representation showing typical reflection and diffraction in a diffractive optical element;

Figure 7 is a schematic representation showing an electronic device, having a virtual display system;

Figure 8 is a schematic representation showing geometry of a generalized 2D exit pupil expander, according to the present invention;

Figure 9a and 9b is a schematic representation of an optical beam propagating in an intermediate diffraction grating (side and top views, respectively), according to the present invention; and

Figure 10 is a schematic representation of a layout of an intermediate diffraction grating, according to the present invention.

Best Mode for Carrying Out the Invention

In the exit pupil extender (EPE) **10**, according to the present invention, has a substrate **20** made of an optical material. On the substrate **20**, there are one input optical element **30** and one or two exit optical elements **50**, as shown in Figure 2. The EPE **10** also has one or two intermediate optical couplers **40**, **40'** each disposed between the input optical element **30** and one of the exit optical elements **50**, **50'**. The couplers **40**, **40'** serve as exit pupil extending components. The optical elements **30**, **50**, **50'** and the couplers **40**, **40'** are diffractive optical elements (DOEs), for example. Each of the DOEs has a plurality of grating lines for diffraction purposes. As shown, the optical element **30** has a plurality of grating lines **32**; the optical element **40** (**40'**) has a plurality of grating lines **42** and the optical element **50** (**50'**) has a plurality of grating lines **52**.

Figure 3 is an isometric view showing the relationship between an input beam **70** and two exit beams **80**, **80'**. As shown, the substrate **20** has a first side **22** and a

second side **24**. The input beam **70** enters the EPE **10** on one side of the substrate **20** and exit beams **80**, **80'** exit the EPE **10** on a different side of the substrate **20**, in a direction substantially parallel to the input beam.

As shown in Figure 2, the grating lines **32** and **52** in DOEs **30** and **50** (**50'**) are substantially parallel to the Y-axis. In order that the DOE **40** (**40'**) acts like a beam extender, and that its efficiency is optimized, the grating lines in the coupler DOEs **40** (**40'**) are substantially at a 60-degree angle in reference to the Y-axis, as shown in Figure 4. As such, the light entering one side of the DOEs **40** (**40'**) is trapped in the grating area between the first side **22** and the second side **24** until it emerges out from the other side of the DOEs **40** (**40'**). Furthermore, the shape of the DOEs **40** (**40'**) is designed so that, at the output end, the rays leaving the grating area are substantially parallel to the X-axis, as shown in Figure 3.

According to one embodiment of the present invention, the grating periods in all DOEs **30**, **40** (**40'**) and **50** (**50'**) are substantially the same. However, while the DOE **30** and **50** (**50'**) have the same period, the DOE **40** is allowed to deviate from those slightly without disturbing the functioning of the EPE system. Nevertheless, each of the gratings has a unique grating profile, optimized to its function. DOE **30** and DOE **40** (**40'**) typically have a deep profile and a proper filling ratio.

As shown in Figure 3, when the EPE **10** is used to expand a light beam **70** incident upon the DOE **30**, the beam **70** is diffracted and reflected, due to total internal reflection (TIR) on one side of substrate **20** (if the DOE **30** is disposed on the upper side **22**, then TIR occurs on the lower side **24**) toward the DOEs **40** (**40'**) substantially along the direction **72** (**72'**). The beam is further diffracted from the DOEs **40** (**40'**) to the direction that makes substantially a 60 degree conical angle with respect to the direction **72** (**72'**). After a TIR in the lower side of the substrate **20**, the beam encounters the grating **40** (**40'**) again and then is diffracted again in a direction parallel to direction **72** (**72'**). Finally, after some successive steps, the beam enters the DOEs **50** (**50'**) substantially along the direction **74** (**74'**), which is substantially the same as direction **72** (**72'**). It is important to ensure that the beam encounters the grating **40** (**40'**) an even number of times. Otherwise the beam does not enter DOE **50** (**50'**) exactly at the correct direction. Finally, the beam exits the DOEs **50**, **50'** as exit beams **80**, **80'**. It should be noted, however, that the cross

section of the exit beams **80, 80'** is larger than that of the input beam **70** as the input beam is expanded in the DOEs both in the Y and X axes. As shown in Figure 3, the incident angle of the light beam entering the DOE **40** is substantially along the direction **72**, which is substantially in the XZ plane. The direction **72** can be
5 calculated from the conical grating equations, and generally in practical cases, the beam in the direction **72** does not exactly travel in the XZ plane, but deviates some degrees from that.

Figure 4 shows the orientation of the grating lines **42** in the DOE **40**. As mentioned above, the grating lines **42** are substantially at a 60-degree angle in
10 reference to the Y-axis. Thus, the grating lines **42** are substantially at a 60-degree conical angle in reference to the incident direction **72** (see Figure 3). However, the conical angle can deviate from 60 degrees as long as in the diffraction there exists only two reflected diffraction modes, zero and first order. It should be noted that, in conical diffraction, the beam is, in general, not perpendicular to the grating lines. The
15 conical angle is defined from the perpendicular position. This condition depends on the incoming beam angles (**70**), grating period and on the refractive index of the material. This acceptable angular space must be calculated case by case using the conical diffraction formulas. This acceptable angular space is generally so large, that the system works in most of the practical cases, even wide field of view cases. As
20 mentioned earlier, it is necessary that the beam meets an even number of times the grating **40 (40')**. Therefore the angle of the leaving edge of the DOE **40 (40')** must be such that this condition is fulfilled. This angle can be calculated from the conical diffraction formulas and the angular spread of the incoming beams. Generally, the leaving edge of DOE **40 (40')** thus forms an angle slightly larger than 30 degrees with
25 respect to the Y-axis. The DOE **40 (40')** is typically a binary type grating and, in the geometry described in this invention, the diffraction efficiency of the first diffraction order can be as high as 90%. Furthermore, the grating efficiency can be tuned to be polarization independent with a proper filling ratio.

The DOE **40'** is substantially a mirror image of the DOE **40**. Thus, the
30 orientation of the grating lines **42'** is similar to that of the grating lines **42**.

As shown in Figure 3, the input beam **70** entering the DOE **30** on one side of the EPE **10**, while the exit beams **80, 80'** leave the DOE **50, 50'** on the other side of

the EPE **10**. It should be noted that generally arrangement of the diffraction gratings in the EPE **10** is such that the exit beams **80** and **80'** exit the EPE **10** also on the same side as the input beam **70** entering the EPE **10**, as shown in Figure 5.

It is known in the art that the beam expansion in the exit beams **80**, **80'** as compared to the input beam **70** is partly due to the different dimensions and shapes in the various DOEs, and partly due to the multiple diffraction and total internal reflection (TIR). As shown in Figure 6, the incoming beam is reflected by TIR at different locations R and diffracted by the grating lines **52** at diffraction locations D, resulting in the exit beam **80**.

The EPE **10** can be used in a portable device **100**, such as a mobile phone, personal digital assistant (PDA), communicator, portable Internet appliance, hand-hand computer, digital video and still camera, wearable computer, computer game device, specialized bring-to-the-eye product for viewing and other portable electronic devices. As shown in Figure 7, the portable device **100** has a housing **210** to a house a communication unit **212** for receiving and transmitting information from and to an external device (not shown). The portable device **100** also has a controlling and processing unit **214** for handling the received and transmitted information, and a virtual display system **230** for viewing. The virtual display system **230** includes a micro-display or image source **192** and an optical engine **190**. The controlling and processing unit **214** is operatively connected to an optical engine **190** to provide image data to the image source **192** to display an image thereon. The EPE **10**, according to the present invention, can be optically linked to an optical engine **190**.

It should be noted that each of the optical elements **30**, **40**, **40'**, **50**, **50'** can be diffractive optical elements having grating lines or a holographic diffractive optical element (HOE) having interference fringes. As the name suggests, a holographic diffraction element is holographically produced where at least two coherent light beams are used to produce the fringes. In contrast, a diffraction optical element can be mechanically or chemically produced.

The objective of the present invention is to achieve efficient optical coupling between the various DOEs in an EPE while the DOEs are sized and shaped and arranged for exit pupil expansion. The application for the EPE of the present invention is not limited to virtual displays. The selective reflection control in a planar

waveguide (substrate **20**), according to the present invention, can also be used in any application where optical beam expansion in one or more directions is required and light of different wavelengths is used. The diffractive elements are, in fact, optical couplers and light modulator devices for coupling light into the planar waveguide.

5 Thus, the EPE **10**, as shown in Figures 2 to 6, can be viewed as an optical device comprised of a planar waveguide and a plurality of optical couplers (or light modulator devices) disposed adjacent to or on the waveguide for light coupling and manipulating purposes.

The image source **192**, as depicted in Figure 7, can be a sequential color
10 LCOS (Liquid Crystal On Silicon) device, an OLED (Organic Light Emitting Diode) array, an MEMS (MicroElectro Mechanical System) device or any other suitable micro-display device operating in transmission, reflection or emission.

Moreover, the electronic device **100** can be a portable device, such as a mobile phone, personal digital assistant (PDA), communicator, portable Internet
15 appliance, hand-held computer, digital video and still camera, wearable computer, computer game device, specialized bring-to-the-eye product for viewing and other portable electronic devices. However, the exit pupil extender, according to the present invention, can also be used in a non-portable device, such as a gaming device, vending machine, band-o-matic, and home appliances, such as an oven, microwave
20 oven and other appliances and other non-portable devices.

Thus, although the invention has been described with respect to a preferred embodiment thereof, it will be understood by those skilled in the art that the foregoing and various other changes, omissions and deviations in the form and detail thereof may be made without departing from the scope of this invention.

25 The further object of the present invention is to provide a general diffractive optics method that uses a plurality of diffractive elements on an optical substrate for expanding the exit pupil of a display of an electronic device for viewing.

According to an embodiment of the present invention, this method can be used for optical coupling in an optical device and it is characterized by expanding of
30 an exit pupil of an input optical beam provided in an output optical beam, wherein the optical device comprises: a substrate of optical material (or an optical substrate) having a first surface and an opposing second surface; a first (in-coupling) diffractive

element disposed on the substrate for receiving an input optical beam (or an input light beam) defined by a wave-vector \mathbf{k}_{in} and containing periodic lines with a period d ; a second (out-coupling) diffractive element disposed on the substrate in relationship with the first diffractive element and containing further periodic lines with the period d , substantially parallel to lines of the first diffractive element; and an intermediate (expanding) diffractive element disposed adjacent to the first and the second diffractive elements, which periodic lines are at an angle ρ with respect to the lines of first and second diffractive element in the plane of the optical substrate.

Furthermore, at least part of the received light beam is diffracted in the first diffractive element for providing a diffracted light component, having a wave-vector \mathbf{k}_0 , to the intermediate diffractive element substantially within the first and second surfaces (e.g., undergoing a total internal reflection). Moreover, at least part of the diffracted light component in the intermediate diffractive element is diffracted again to the first diffraction order, having wave-vector \mathbf{k}_2 , and finally coupled to the second diffractive element substantially between the first and second surfaces (again, e.g., undergoing a total internal reflection) so as to allow at least part of the coupled diffracted light component to exit the substrate by diffraction in the second diffractive element thus providing an output optical beam defined by a further wave-vector \mathbf{k}_{out} . Typically, the second diffractive element generates also another output beam, which wave-vector is a mirror image of the wave vector \mathbf{k}_{out} with respect to the substrate surface. As this wave vector is otherwise identical to the wave vector \mathbf{k}_{out} and in real applications it is intentionally damped to a low value, therefore it is not considered further separately from the wave vector \mathbf{k}_{out} .

According to an embodiment of the present invention, the intermediate diffraction grating contains still further periodic lines with an angle (or a rotation angle) between the periodic lines of the first diffractive element and the still further periodic lines of ρ , and the period d' of the still further periodic lines is given by

$$0.9d/2\cos\rho < d' < 1.1d/2\cos\rho \quad (1).$$

According to an embodiment of the present invention, a light component is incident and diffracted (e.g., to a first order) on the intermediate diffraction element an even number of times before providing said at least part of the diffracted light component to the second diffraction element. The fact of said even number of

diffractions on the intermediate diffraction element implies, as proven below, that the further wave-vector \mathbf{k}_2 has exactly the same direction as the wave-vector \mathbf{k}_0 , which is generated from the input optical beam with the wave-vector \mathbf{k}_{in} under appropriate operating conditions, i.e., the system is geometrically accurate.

5 Moreover, according to an embodiment of the present invention, the first diffractive element, the second diffractive element or the intermediate diffractive element can be disposed on the first surface or on the second surface of the optical substrate. Furthermore, according to an embodiment of the present invention, the first
10 diffractive element, the second diffractive element or the intermediate diffractive element can be a planar diffraction grating manufactured using lithographic methods or classically ruled (having different groove angles and profiles, such as binary, triangular, sinusoidal, etc.).

 The generalized method, according to the present invention provides conditions for supporting a broad variety of rotations angles ρ such that the system is
15 geometrically accurate (i.e., wave-vectors \mathbf{k}_{in} and \mathbf{k}_{out} have the same direction). The period of the first diffractive element is such that it supports only zero and first order transmissive diffraction modes, which are used to couple the light into the substrate. It is shown below that if the intermediate diffractive element supports only the zero and first order reflective modes and other modes are forbidden, then the system can
20 support a broad range of rotation angles $0 < \rho < 70^\circ$ and beyond. That means that a broad range of conical incident angles (at least between 0 and 70° and beyond) can be supported by the intermediate diffractive element (the conical angle is an angle between the plane of an incident beam and a plane perpendicular to the periodic lines).

25 Figure 8 shows one example among others of a schematic representation for geometry of a generalized two-dimensional (2D) exit pupil expander (EPE) **300**, according to the present invention, illustrating the general diffractive optics method described above. Figure 8 shows a top view of an optical substrate (plate) **250** with three diffractive elements disposed on the optical substrate **250**: the first (in-coupling)
30 diffractive element (an in-coupling diffraction grating) **270** having the line period d , the second diffractive element (an out-coupling diffraction grating) **280** having the line period d (periodic lines of the gratings **270** and **280** are being parallel) and the intermediate (expanding) diffracting element (an intermediate diffraction grating) **260**

having the line period d' given by the Equation 1 and which periodic lines are at an angle ρ with respect to the lines of first and second diffractive elements **270** and **280** in the plane of the optical substrate, as shown in Figure 8.

In order to prove that the angles are preserved when the optical beam is diffracted to the first order two times from the same diffraction grating, Figures 9a and 9b show a schematic representation (side and top views, respectively) of an optical substrate (transparent plate) **250** of Figure 8 with the intermediate diffraction grating **260** disposed on its surface.

The optical beam entering the diffraction grating **260** is described by a wave-vector \mathbf{k}_0 which has component angles (θ_0, φ_0) which are formed with a coordinate axis in the plane of the plate **250** perpendicular to periodic lines of the grating **260** and an axis perpendicular to the surface of the optical substrate **250**, respectively. The angles (θ_0, φ_0) are the result of the first order diffraction from the in-coupling grating and are governed by equations

$$15 \quad \begin{cases} n \sin \theta_0 \sin \varphi_0 = \sin \theta_{in} \sin \varphi_{in} \\ n \sin \theta_0 \cos \varphi_0 = \sin \theta_{in} \cos \varphi_{in} + \frac{\lambda}{d} \end{cases} \quad (2),$$

wherein the +1 transmissive order has been chosen for consideration. For the other mode -1 we get similar equations, but the signs of modes are reversed. The refractive index of the plate **250** is n and for air the index of refraction is 1. The optical beam is diffracted to reflected orders -1 and 0. For the angles of the diffracted mode -1 we have a pair of equations

$$20 \quad \begin{cases} n \sin \theta_1 \sin \varphi_1 = n \sin \theta_0 \sin(\varphi_0 + \rho) \\ n \sin \theta_1 \cos \varphi_1 = n \sin \theta_0 \cos(\varphi_0 + \rho) - \frac{\lambda}{d'} \end{cases} \quad (3),$$

which define the components of the wave-vector \mathbf{k}_1 , described by the angles (θ_1, φ_1) which are formed with the same coordinate axes as angles (θ_0, φ_0) .

25 The optical beam propagates to the upper surface and then after total internal reflection to the lower surface where it meets again the grating **260**. This optical beam will be diffracted to the reflected order 1 and 0 by the diffraction grating **260**. The

reflected order 1 has angles (θ_2, φ_2) which are formed with the same coordinate axes as angles (θ_0, φ_0) inside the plate **250**. The wave-vector \mathbf{k}_2 is now defined by equations

$$\begin{cases} n \sin \theta_2 \sin \varphi_2 = n \sin \theta_1 \sin \varphi_1 = n \sin \theta_0 \sin(\varphi_0 + \rho) \\ n \sin \theta_2 \cos \varphi_2 = n \sin \theta_1 \cos \varphi_1 + \frac{\lambda}{d}, = n \sin \theta_0 \cos(\varphi_0 + \rho) \end{cases} \quad (4),$$

5 from where we see that $\theta_0 = \theta_2$ and $\varphi_0 = \varphi_2 - \rho$.

The optical beam described by the wave-vector \mathbf{k}_2 is then coupled to the out-coupling diffraction grating **280**. Finally the out-coupling grating **280** couples the beam out from the plate to the wave-vector \mathbf{k}_{out} described by angles $(\theta_{out}, \varphi_{out})$. The equations are

$$10 \quad \begin{cases} \sin \theta_{out} \sin \varphi_{out} = n \sin \theta_2 \sin(\varphi_2 - \rho) = \sin \theta_{in} \sin \varphi_{in} \\ \sin \theta_{out} \cos \varphi_{out} = n \sin \theta_2 \cos(\varphi_2 - \rho) - \frac{\lambda}{d} = \sin \theta_{in} \cos \varphi_{in} \end{cases} \quad (5).$$

This proves that the beam direction is unchanged when the light beams escaping the intermediate grating area have an even number of first order diffractions from the grating. This principle is further demonstrated in the example of Figure 10.

15 To guarantee, that there are exactly even number of first order diffractions in the intermediate diffraction grating that are redirected to the out-coupling grating, the leaving edge of the intermediate diffraction grating **260** must be at certain angle with respect to the grating lines, as shown in Figure 10. The relation for the angle is

$$\varepsilon \leq \min \left\{ \tan^{-1} \left| \frac{\sin \theta_{in} \cos(\varphi_{in} + \rho) - \frac{\lambda}{d} \cos \rho}{\sin \theta_{in} \sin(\varphi_{in} + \rho) + \frac{\lambda}{d} \sin \rho} \right| \right\} \quad (6).$$

20 The angles $(\theta_{in}, \varphi_{in})$ are any angles in the specified field of view.

To guarantee that there in the intermediate grating are only zero and first reflective diffraction order, we need to place some requirements to the grating period and the rotation angle in addition to the range of the line period d' given by the Equation 1.

Using conical equations, the wave-vector component in the direction perpendicular to the surface of the optical substrate **250** inside the optical substrate **250** can be calculated which allows to derive a condition for modes -1 and 0 to exist as described by

$$5 \quad n > \frac{\lambda}{d} \quad (7).$$

This condition of Equation 8 is valid in all practical cases as far the rotation angle ρ is concerned.

The condition that there are no transmissive modes in the intermediate diffraction grating is $\lambda/d > 1$ and it is valid in all practical cases. Another
 10 requirement is that no other reflected modes should exist in the intermediate diffraction grating. It is enough to consider only the lowest of the diffraction modes, *i.e.*, -2 and $+1$, and we get accordingly a condition

$$\sqrt{1 + 8 \cos^2 \rho} > \frac{nd}{\lambda} \quad (8).$$

This condition described by Equation 5 is typically valid for $0 < \rho < 70^\circ$. That
 15 means that a broad range of conical incident angles (at least between 0 and 70° and beyond) can be supported by the intermediate diffraction grating (the conical angle is the angle $\varphi_0 + \rho$ in Figure 8), wherein the range for the line period d' is given by the Equation 1. The range for d' given by Equation 1 can be significantly broader under different conditions. For example, it can be shown that for $\rho = 60^\circ$ and a horizontal
 20 field of view of $\pm 12^\circ$ the range for d' is extended to $0.66d/2\cos\rho < d' < 1.24d/2\cos\rho$.

The efficiency of the intermediate diffraction grating reaches very high values at about 60° rotation angle such that the diffraction efficiencies are almost equal for both TE and TM polarizations.

It is to be understood that the above-described arrangements are only
 25 illustrative of the application of the principles of the present invention. Numerous modifications and alternative arrangements may be devised by those skilled in the art without departing from the scope of the present invention, and the appended claims are intended to cover such modifications and arrangements.

What is claimed is:

1. An optical device (10, 300) comprising:
 - a substrate (20, 250) of optical material having a first surface and an opposing second surface;
 - 5 a first diffractive (30, 270) element disposed on the substrate for receiving a light beam;
 - a second diffractive element (50, 280) disposed on the substrate (20, 250) in relationship with the first diffractive element; and
 - an intermediate diffractive element (40, 260) disposed between the first and
 - 10 the second diffractive elements, wherein
at least part of the received light beam is diffracted in the first diffractive element (30, 270) for providing a diffracted light component to the intermediate diffractive element (40, 280) in an incident direction substantially within the first and second surfaces, and
 - 15 at least part of the diffracted light component in the intermediate different element (40, 260) is coupled to the second diffractive element (50, 280) substantially between the first and second surfaces so as to allow at least part of the coupled diffracted light component to exit the substrate (20, 250) by diffraction in the second diffractive element (50, 280), wherein the intermediate diffractive element (40, 260)
 - 20 has a substantially periodic pattern composed of substantially linear elements along a pattern direction for producing conical diffraction.
2. The optical device (10) of claim 1, wherein angle in the conical diffraction is between 50 and 70 degrees.
- 25 3. The optical device (10) of claim 1, wherein the intermediate diffractive element (50) has a substantially periodic pattern composed of substantially linear elements along a pattern direction so that the incident direction (72) of the diffracted light component provided to the intermediate different element is within an angular
- 30 range between 20 and 40 degrees relative to the pattern direction.
4. The optical device (10) of claim 3, further comprising:

a third diffractive element (50') disposed on the substrate in relationship with the first diffractive element (30) spaced from the second diffractive element (50); and a further intermediate diffractive element (40') disposed between the first and the third diffractive elements, wherein

5 at least part of the received light beam is diffracted in the first diffractive element (30) for providing a diffracted light component to the further intermediate diffractive element (40') in an incident direction within the first and second surface (22, 24), and

10 at least part of the diffracted light component in the further intermediate different element (40') is coupled to the third diffractive element (50') substantially between the first and second surfaces (22, 24) so as to allow at least part of the coupled diffracted light component to exit the substrate by diffraction in the third diffractive element (50'), wherein the further intermediate diffractive element (40') has a substantially periodic pattern composed of substantially linear elements along a
15 pattern direction such that the incident (72') direction of the diffracted light component provided to the further intermediate different element (40') is within an angular range between 50 and 70 degrees relative to the pattern direction.

5. The optical device (10) of claim 1, wherein the received light beam (70) is
20 received in the first diffractive element through the first surface and at least part of the coupled diffracted light component exits the substrate through the second surface.

6. The optical device (10) of claim 1, wherein the received light beam is received
25 in the first diffractive element (70) through the first surface and at least part of the coupled diffracted light component exits the substrate through the first surface.

7. The optical device (10, 300) of claim 1, wherein the intermediate diffractive element (40, 260) comprises a plurality of grooves forming the period pattern.

30 8. The optical device (10) of claim 1, wherein the first diffractive element (30) has a period pattern composed of a plurality of linear elements along a pattern direction substantially perpendicular to the incident direction.

9. The optical device (10) of claim 1, wherein the second diffractive element (50) has a period pattern composed of a plurality of linear elements along a pattern direction substantially perpendicular to the incident direction.
- 5 10. The optical device (300) of claim 1, wherein
said light beam is defined by a wave-vector \mathbf{k}_{in} and said first diffraction
element (270) contains periodic lines with a period d ;
said second diffractive element (280) contains further periodic lines with a
period of d , wherein said further periodic lines are parallel to said periodic lines of
10 the first diffractive element;
said intermediate diffractive element (260) contains still further periodic lines
with the period defined by a range $0.9d/2\cos\rho$ to $1.1d/2\cos\rho$, wherein ρ is an angle
between said periodic lines and the still further periodic lines; and
said at least part of the coupled diffracted light component exits the substrate
15 (250) by said diffraction in the second diffractive element thus providing an output
light beam defined by a further wave-vector \mathbf{k}_{out} having exactly the same direction as
the wave-vector \mathbf{k}_{in} of said light beam.
11. The optical device (300) of claim 10, wherein said at least part of the
20 diffracted light component is further diffracted to a first order from said intermediate
diffraction element (260) an even number of times before providing said at least part
of the diffracted light component to said second diffractive element.
12. The optical device (300) of claim 10, wherein said intermediate diffractive
25 element (260) supports only reflective zero and reflective first order diffraction
modes, or an index of refraction of said substrate is $n > \lambda/d$, wherein λ is a wavelength
of the input optical beam.
13. The optical device (300) of claim 10, wherein a predetermined condition is
30 maintained, said condition is that a second or higher order modes are unsupported by
said intermediate diffractive element (260), or said condition is expressed as

$\sqrt{1+8\cos^2\rho} > \frac{nd}{\lambda}$, wherein n is an index of refraction of said substrate, λ is a wavelength of the input optical beam.

14. The optical device (300) of claim 13, wherein $0 < \rho < 70^\circ$.

5

15. The optical device (300) of claim 10, wherein a predetermined condition is maintained, said condition is that transmission modes are unsupported for said intermediate diffractive element (260), or said condition is expressed as $\lambda/d > 1$, wherein λ is a wavelength of the input optical beam.

10

16. The optical device (300) of claim 10, wherein said first diffractive element (270), said second diffractive element (280) or said intermediate diffractive element (260) is disposed on said first surface or on said second surface.

15 17. A method of optical coupling in an optical device, the optical device comprising:

a substrate (20, 250) of optical material having a first surface and an opposing second surface;

20 a first diffractive element (30, 270) disposed on the substrate for receiving a light beam, wherein at least part of the received light beam is diffracted in the first diffractive element (30, 270) for providing a diffracted light component; and

25 a second diffractive element (50, 280) disposed on the substrate (20, 250) in relationship to the first diffractive element (30, 270) so as to allow at least part of the diffracted light component to exit the substrate substantially by diffraction in the second diffractive element, said method comprising:

30 disposing an intermediate diffractive element (40, 260) between the first and the second diffractive elements, so as to allow part of the diffracted light component to enter the intermediate diffractive element (40, 260) between the first and second surfaces at an incident direction, wherein the intermediate diffractive element has a substantially periodic pattern composed of substantially linear elements along a pattern direction to produce conical diffraction.

18. The method of claim 17, wherein the intermediate diffractive element (50) has a substantially periodic pattern composed of substantially linear elements along a pattern direction such that the incident direction (72) of the diffracted light component is within an angular range between 20 and 40 degrees relative to the pattern direction.

19. The method of claim 18, wherein the optical device further comprises a third diffractive element (50') disposed on the substrate in relationship to the first diffractive element (30) spaced from the second diffractive element (50) so as to allow at least part of the diffracted light component also to exit the substrate substantially by diffraction in the third diffractive element (50'), said method further comprising:

disposing a further intermediate diffractive element (40') between the first and the third diffractive elements, so as to allow part of the diffracted light component to enter the further intermediate diffractive element (40') between the first and second surfaces at an incident direction (72'), wherein the intermediate diffractive element (40') has a substantially periodic pattern composed of substantially linear elements along a pattern direction such that the incident direction (72') of the diffracted light component is within an angular range between 50 and 70 degrees relative to the pattern direction.

20. The method of claim 17, wherein the first diffractive element (30) having a substantially period pattern composed of substantially linear elements along a first pattern direction, and the second diffractive element (50) having a substantially period pattern composed of substantially linear elements along a second pattern direction substantially parallel to the first pattern direction.

21. The method of claim 17, wherein
said light beam is defined by a wave-vector \mathbf{k}_{in} and said first diffraction element (270) contains periodic lines with a period d ;
said second diffractive element (280) contains further periodic lines with a period of d , wherein said further periodic lines are parallel to said periodic lines of the first diffractive element;

said intermediate diffractive element (260) contains still further periodic lines with the period defined by a range $0.9d/2\cos\rho$ to $1.1d/2\cos\rho$, wherein ρ is an angle between said periodic lines and the still further periodic lines; and

5 said at least part of the coupled diffracted light component exits the substrate (250) by said diffraction in the second diffractive element thus providing an output light beam defined by a further wave-vector \mathbf{k}_{out} having exactly the same direction as the wave-vector \mathbf{k}_{in} of said light beam.

22. The optical device of claim 21, wherein said at least part of the diffracted light
10 component is further diffracted to a first order from said intermediate diffraction element (260) an even number of times before providing said at least part of the diffracted light component to said second diffractive element.

23 An electronic device (100) comprising:
15 a data processing unit (214);
an optical engine (190) operatively connected to the data processing unit for receiving image data from the data processing unit;
a display device (192) operatively connected to the optical engine for forming an image based on the image data; and
20 an exit pupil extender (10), comprising:
a substrate (20, 250) of optical material having a first surface and an opposing second surface;
a first diffractive element (30, 270) disposed on the substrate for receiving a light beam;
25 a second diffractive element (50, 280) disposed on the substrate (20, 250) in relationship with the first diffractive element; and
an intermediate diffractive element (40, 260) disposed between the first and the second diffractive elements, wherein
at least part of the received light beam is diffracted in the first
30 diffractive element (30,270) for providing a diffracted light component to the intermediate diffractive element (40,280) in an incident direction substantially within the first and second surfaces, and

at least part of the diffracted light component in the intermediate different element (40, 260) is coupled to the second diffractive element (50,280) substantially between the first and second surfaces so as to allow at least part of the coupled diffracted light component to exit the substrate (20, 250) by diffraction in the second diffractive element (50, 280), wherein the intermediate diffractive element (40,260) has a substantially periodic pattern composed of substantially linear elements along a pattern direction for producing conical diffraction.

24. The electronic device (100) of claim 23, wherein angle in the conical diffraction is between 50 and 70 degrees.

25. The electronic device (100) of claim 23, wherein the intermediate diffractive element has a substantially periodic pattern composed of substantially linear elements along a pattern direction so that the incident direction (72) of the diffracted light component provided to the intermediate different element is within an angular range between 20 and 40 degrees relative to the pattern direction.

26. The electronic device (100) of claim 25, wherein the optical device further comprises:

a third diffractive element (50') disposed on the substrate in relationship with the first diffractive element spaced (30) from the second diffractive element (50); and a further intermediate diffractive element (40') disposed between the first and the third diffractive elements, wherein

at least part of the received light beam is diffracted in the first diffractive element (30) for providing a diffracted light component to the further intermediate diffractive element (40') in an incident direction within the first and second surface (22, 24), and

at least part of the diffracted light component in the further intermediate different element (40') is coupled to the third diffractive element (50') substantially between the first and second surfaces (22, 24) so as to allow at least part of the coupled diffracted light component to exit the substrate by diffraction in the third diffractive element (50'), wherein the further intermediate diffractive element (40')

has a substantially periodic pattern composed of substantially linear elements along a pattern direction such that the incident direction (72') of the diffracted light component provided to the further intermediate different element (40') is within an angular range between 50 and 70 degrees relative to the pattern direction.

5

27. The electronic device (100) of claim 23, comprising a computer game device or a digital camera.

28. The electronic device (100) of claim 23, further comprising a communications
10 unit (212) for receiving signals containing information indicative of the image data, wherein the data processing unit is operatively connected to the communications unit for receiving the information.

29. The electronic device (10) of claim 28, comprising a mobile terminal.

15

30. The electronic device (100) of claim 23, wherein
said light beam is defined by a wave-vector \mathbf{k}_{in} and said first diffraction
element (270) contains periodic lines with a period d ;
said second diffractive element (280) contains further periodic lines with a
20 period of d , wherein said further periodic lines are parallel to said periodic lines of the
first diffractive element;

said intermediate diffractive element (260) contains still further periodic lines
with the period defined by a range $0.9d/2\cos\rho$ to $1.1d/2\cos\rho$, wherein ρ is an angle
between said periodic lines and the still further periodic lines; and

25 said at least part of the coupled diffracted light component exits the substrate
(250) by said diffraction in the second diffractive element thus providing an output
light beam defined by a further wave-vector \mathbf{k}_{out} having exactly the same direction as
the wave-vector \mathbf{k}_{in} of said light beam.

30 31. The electronic device (100) of claim 30, wherein said at least part of the
diffracted light component is further diffracted to a first order from said intermediate
diffraction element (260) an even number of times before providing said at least part
of the diffracted light component to said second diffractive element.

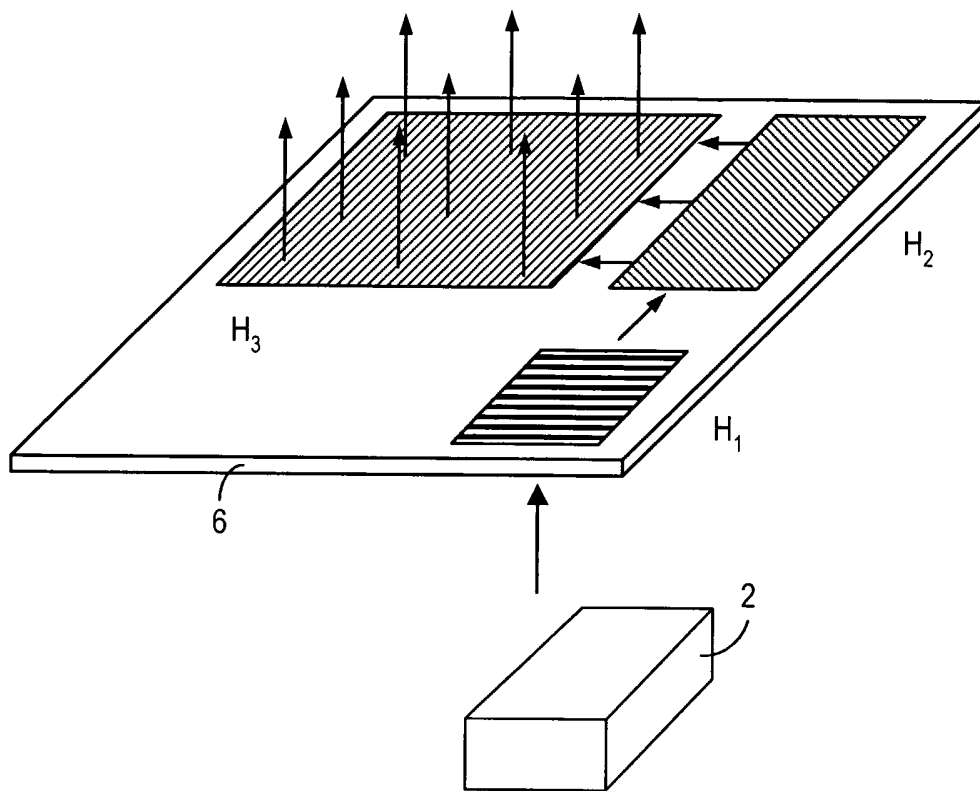

FIG. 1
(prior art)

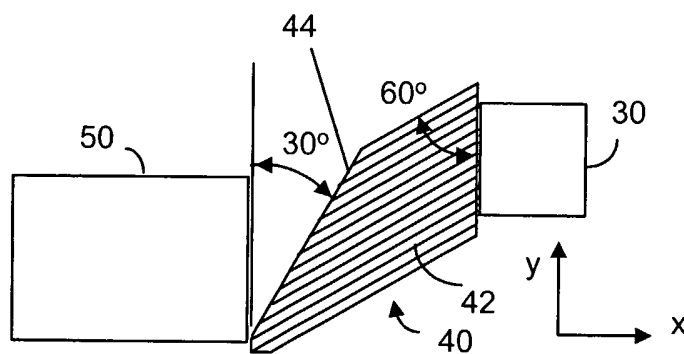

FIG. 4

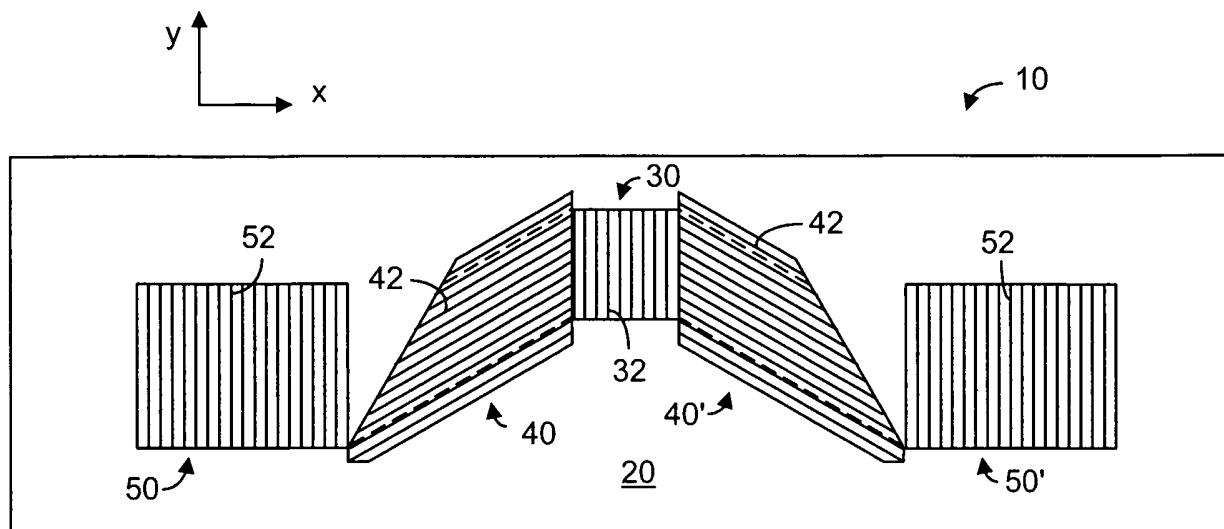

FIG. 2

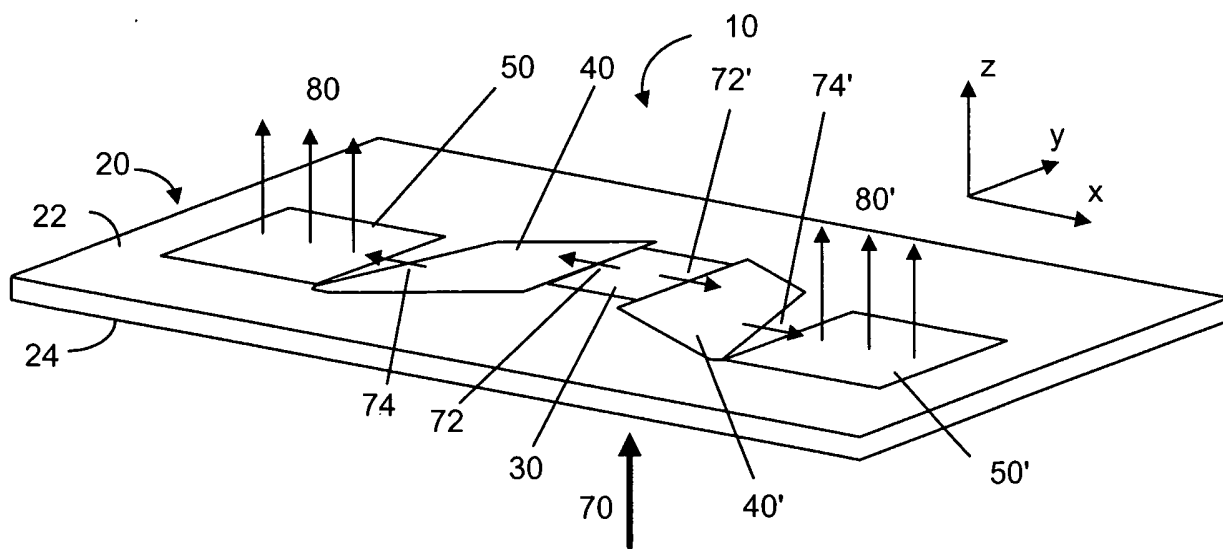

FIG. 3

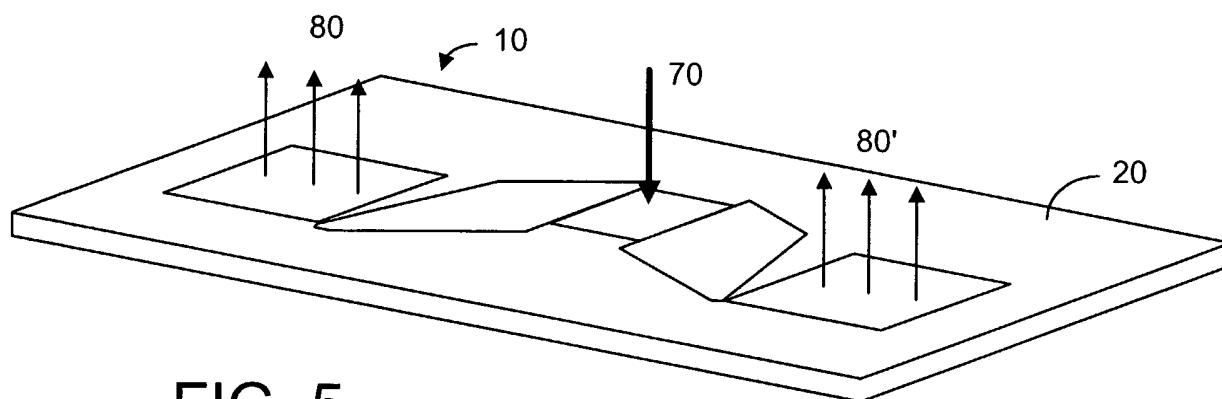

FIG. 5

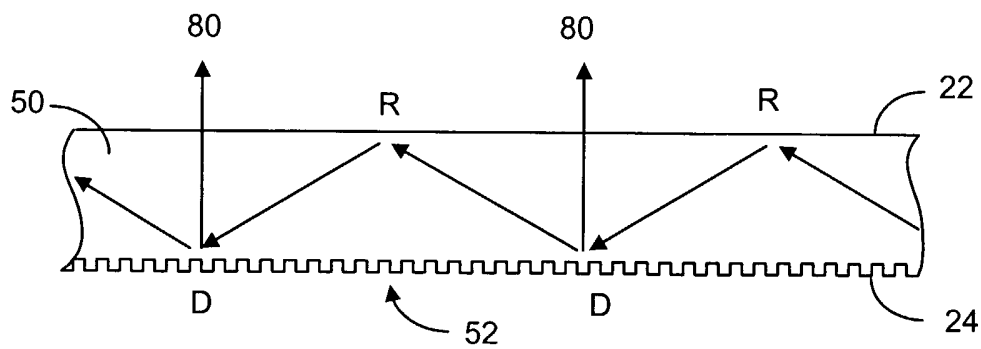

FIG. 6

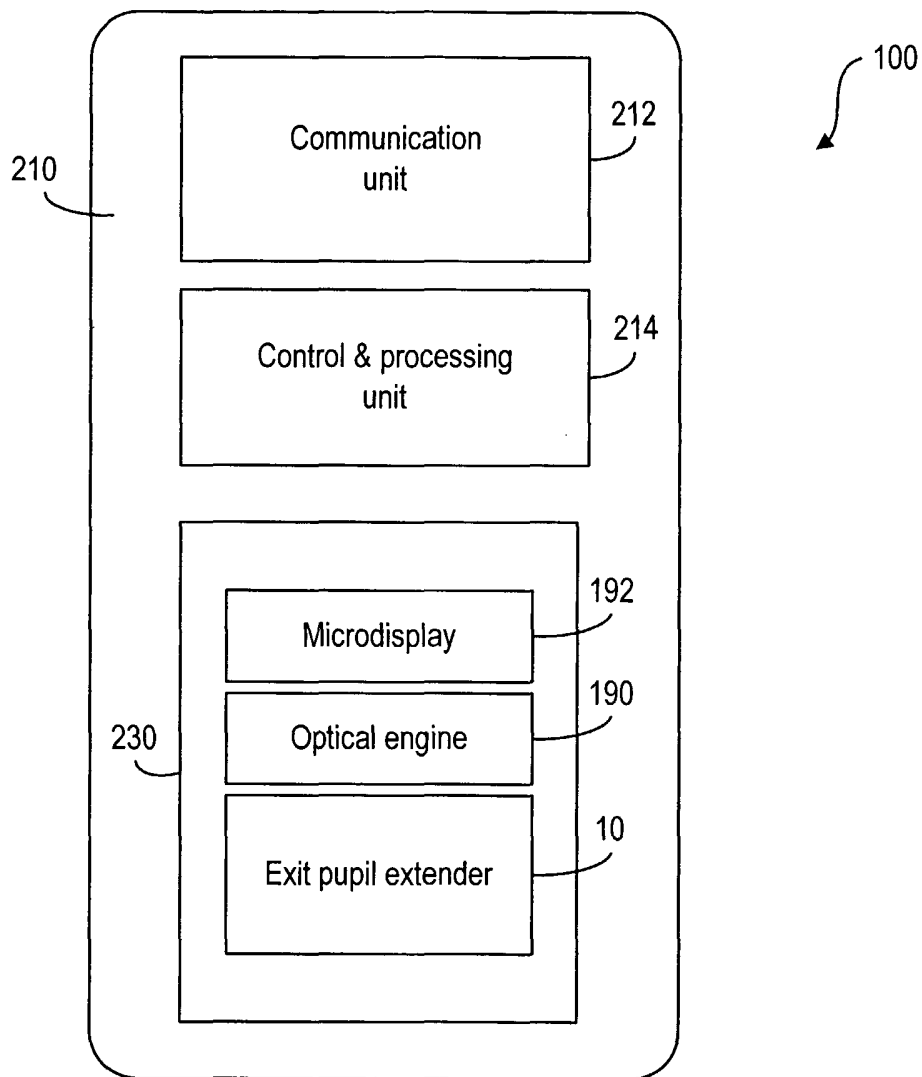

FIG. 7

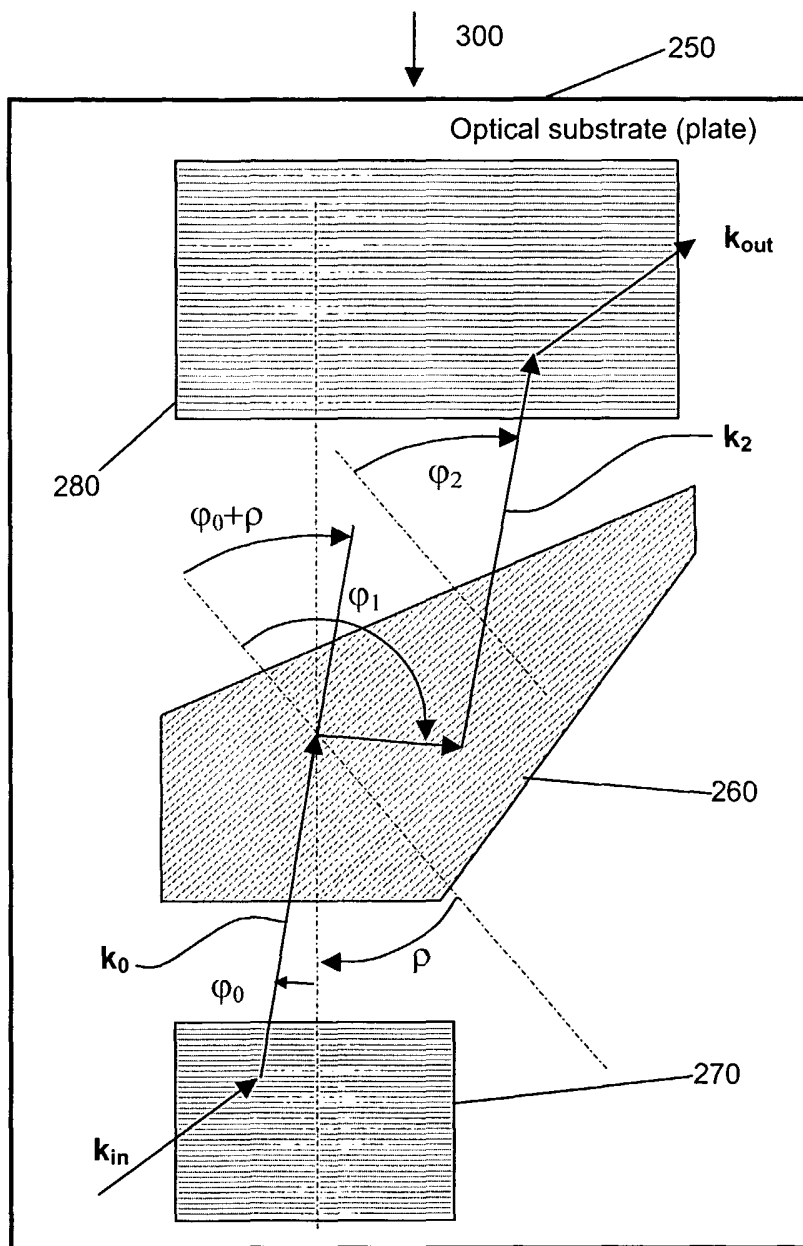

FIG. 8

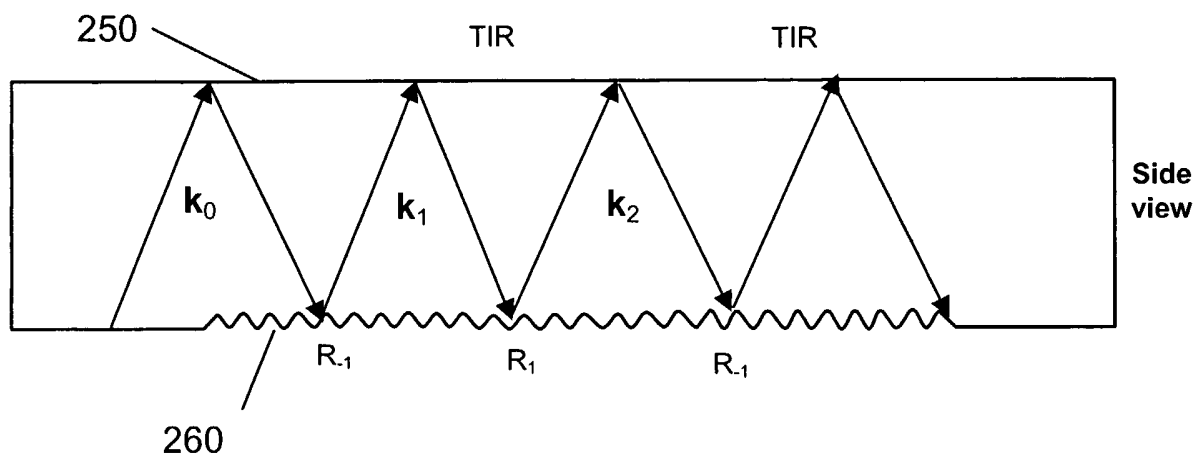

FIG. 9a

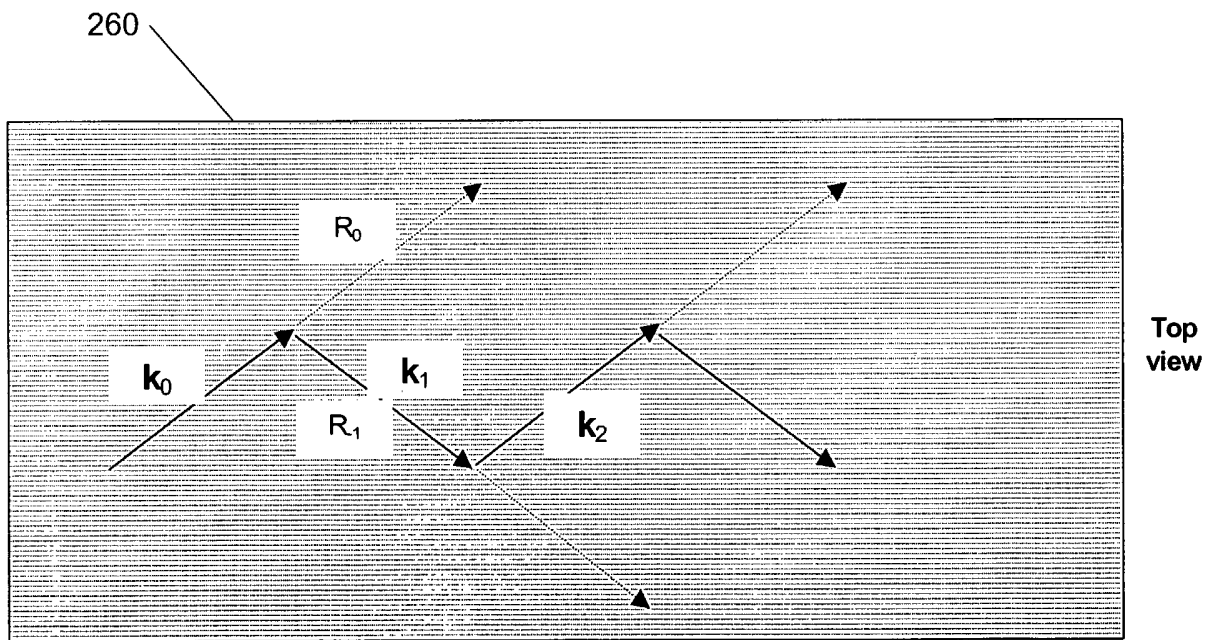

FIG. 9b

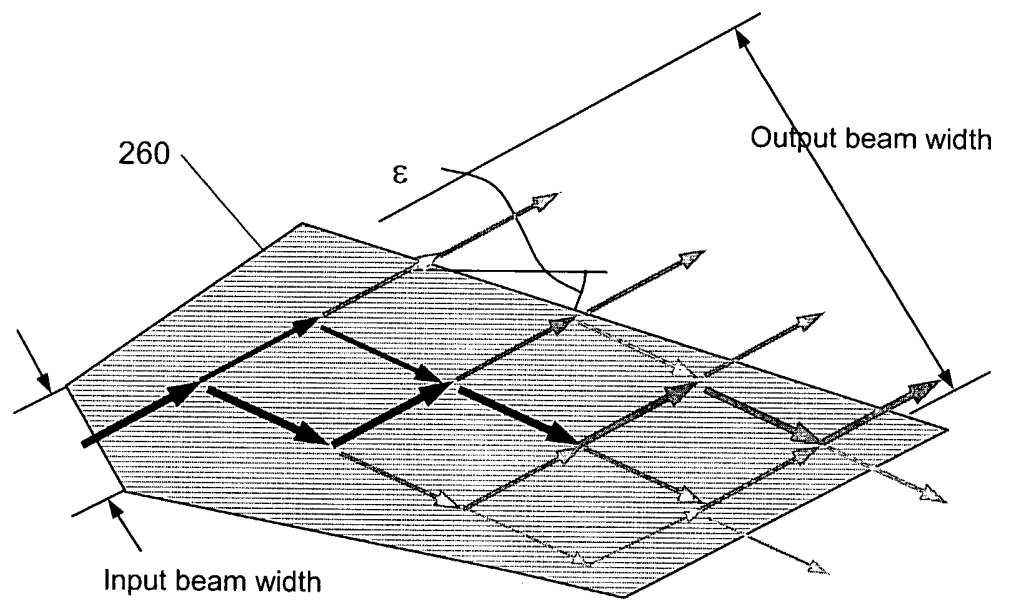

FIG. 10

INTERNATIONAL SEARCH REPORT

International application No.

PCT/IB2005/003749

A. CLASSIFICATION OF SUBJECT MATTER				
IPC: see extra sheet According to International Patent Classification (IPC) or to both national classification and IPC				
B. FIELDS SEARCHED				
Minimum documentation searched (classification system followed by classification symbols)				
IPC: G02B				
Documentation searched other than minimum documentation to the extent that such documents are included in the fields searched				
SE,DK,FI,NO classes as above				
Electronic data base consulted during the international search (name of data base and, where practicable, search terms used)				
EPO-INTERNAL, WPI DATA, PAJ				
C. DOCUMENTS CONSIDERED TO BE RELEVANT				
Category*	Citation of document, with indication, where appropriate, of the relevant passages	Relevant to claim No.		
A	US 6580529 B1 (YAAKOV AMITAI ET AL), 17 June 2003 (17.06.2003), figure 1 --	1-31		
A	US 20040233534 A1 (HIDEYUKI NAKANISHI ET AL), 25 November 2004 (25.11.2004), abstract --	1-31		
A	WO 2004055556 A1 (NOKIA CORPORATION), 1 July 2004 (01.07.2004), abstract --	1-31		
A	PATENT ABSTRACTS OF JAPAN 57014806 (TOMIJIMA TAKUMI) 26 January 1982 (1982-01-26) abstract --	1-31		
<input type="checkbox"/> Further documents are listed in the continuation of Box C. <input checked="" type="checkbox"/> See patent family annex.				
<table style="width: 100%; border: none;"> <tr> <td style="width: 50%; border: none; vertical-align: top;"> * Special categories of cited documents: "A" document defining the general state of the art which is not considered to be of particular relevance "E" earlier application or patent but published on or after the international filing date "L" document which may throw doubts on priority claim(s) or which is cited to establish the publication date of another citation or other special reason (as specified) "O" document referring to an oral disclosure, use, exhibition or other means "P" document published prior to the international filing date but later than the priority date claimed </td> <td style="width: 50%; border: none; vertical-align: top;"> "T" later document published after the international filing date or priority date and not in conflict with the application but cited to understand the principle or theory underlying the invention "X" document of particular relevance: the claimed invention cannot be considered novel or cannot be considered to involve an inventive step when the document is taken alone "Y" document of particular relevance: the claimed invention cannot be considered to involve an inventive step when the document is combined with one or more other such documents, such combination being obvious to a person skilled in the art "&" document member of the same patent family </td> </tr> </table>			* Special categories of cited documents: "A" document defining the general state of the art which is not considered to be of particular relevance "E" earlier application or patent but published on or after the international filing date "L" document which may throw doubts on priority claim(s) or which is cited to establish the publication date of another citation or other special reason (as specified) "O" document referring to an oral disclosure, use, exhibition or other means "P" document published prior to the international filing date but later than the priority date claimed	"T" later document published after the international filing date or priority date and not in conflict with the application but cited to understand the principle or theory underlying the invention "X" document of particular relevance: the claimed invention cannot be considered novel or cannot be considered to involve an inventive step when the document is taken alone "Y" document of particular relevance: the claimed invention cannot be considered to involve an inventive step when the document is combined with one or more other such documents, such combination being obvious to a person skilled in the art "&" document member of the same patent family
* Special categories of cited documents: "A" document defining the general state of the art which is not considered to be of particular relevance "E" earlier application or patent but published on or after the international filing date "L" document which may throw doubts on priority claim(s) or which is cited to establish the publication date of another citation or other special reason (as specified) "O" document referring to an oral disclosure, use, exhibition or other means "P" document published prior to the international filing date but later than the priority date claimed	"T" later document published after the international filing date or priority date and not in conflict with the application but cited to understand the principle or theory underlying the invention "X" document of particular relevance: the claimed invention cannot be considered novel or cannot be considered to involve an inventive step when the document is taken alone "Y" document of particular relevance: the claimed invention cannot be considered to involve an inventive step when the document is combined with one or more other such documents, such combination being obvious to a person skilled in the art "&" document member of the same patent family			
Date of the actual completion of the international search		Date of mailing of the international search report		
5 April 2006		07-04-2006		
Name and mailing address of the ISA/ Swedish Patent Office Box 5055, S-102 42 STOCKHOLM Facsimile No. +46 8 666 02 86		Authorized officer Sture Elnäs/MN Telephone No. +46 8 782 25 00		

INTERNATIONAL SEARCH REPORT

International application No.
PCT/IB2005/003749

International patent classification (IPC)

G02B 27/01 (2006.01)

Download your patent documents at www.prv.se

Cited patent documents can be downloaded at www.prv.se by following the links e-tjänster/anförda dokument. Use the application number as username. The password is **3w8qc3jg1j**.

Paper copies can be ordered at a cost of 50 SEK per copy from PRV InterPat (telephone number 08-782 28 85).

Cited literature, if any, will be enclosed in paper form.

INTERNATIONAL SEARCH REPORT

International application No.

31/12/2005

PCT/IB2005/003749

US	6580529	B1	17/06/2003	AT	254291	T	15/11/2003
				AU	3052499	A	25/10/1999
				CA	2326767	A	14/10/1999
				DE	69912759	D,T	30/09/2004
				EP	1068548	A,B	17/01/2001
				IL	138657	D	00/00/0000
				WO	9952002	A	14/10/1999

US	20040233534	A1	25/11/2004	JP	2001059905	A	06/03/2001
				US	6728034	B	27/04/2004
				US	6947213	B	20/09/2005

WO	2004055556	A1	01/07/2004	AU	2003285384	A	00/00/0000
				EP	1573369	A	14/09/2005
				FI	114946	B	31/01/2005
				FI	20022199	A	17/06/2004
