



INTERNATIONAL APPLICATION PUBLISHED UNDER THE PATENT COOPERATION TREATY (PCT)

<p>(51) International Patent Classification ⁶ : A61M 1/38, B01D 11/04</p>	<p>A1</p>	<p>(11) International Publication Number: WO 95/03840 (43) International Publication Date: 9 February 1995 (09.02.95)</p>
<p>(21) International Application Number: PCT/AU94/00415 (22) International Filing Date: 22 July 1994 (22.07.94) (30) Priority Data: PM 0287 30 July 1993 (30.07.93) AU (71) Applicant (for all designated States except US): THE UNIVERSITY OF QUEENSLAND [AU/AU]; St Lucia, QLD 4067 (AU). (72) Inventor; and (75) Inventor/Applicant (for US only): CHAM, Bill, Elliot [NL/AU]; 373 Woodlands Drive, Sheldon, QLD 4157 (AU). (74) Agent: CULLEN & CO.; Level 12, 240 Queen Street, Brisbane, QLD 4000 (AU).</p>		<p>(81) Designated States: AT, AU, BB, BG, BR, BY, CA, CH, CN, CZ, DE, DK, ES, FI, GB, GE, HU, JP, KE, KG, KP, KR, KZ, LK, LT, LU, LV, MD, MG, MN, MW, NL, NO, NZ, PL, PT, RO, RU, SD, SE, SI, SK, TJ, TT, UA, US, UZ, VN, European patent (AT, BE, CH, DE, DK, ES, FR, GB, GR, IE, IT, LU, MC, NL, PT, SE), OAPI patent (BF, BJ, CF, CG, CI, CM, GA, GN, ML, MR, NE, SN, TD, TG), ARIPO patent (KE, MW, SD). Published With international search report.</p>

(54) Title: A PLASMA DELIPIDATION SYSTEM

(57) Abstract

An improved separating device for extracting cholesterol from plasma uses a spinner (45) to disperse incoming plasma laterally into an extracting solvent in the form of fine droplets to improve separation efficiency thereby making it suitable for delipidating blood plasma.

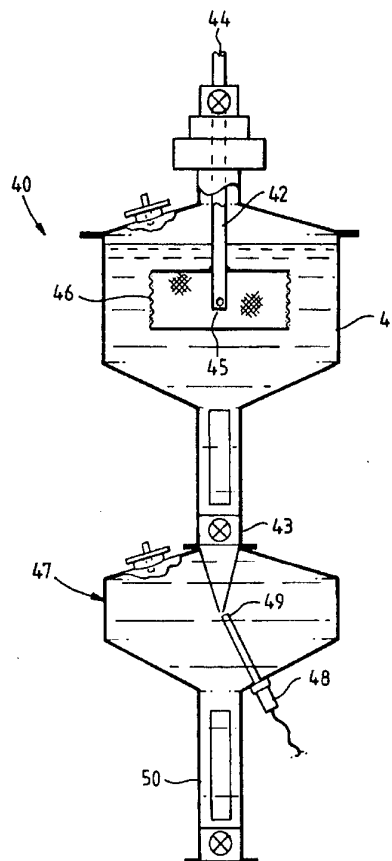

FOR THE PURPOSES OF INFORMATION ONLY

Codes used to identify States party to the PCT on the front pages of pamphlets publishing international applications under the PCT.

AT	Austria	GB	United Kingdom	MR	Mauritania
AU	Australia	GE	Georgia	MW	Malawi
BB	Barbados	GN	Guinea	NE	Niger
BE	Belgium	GR	Greece	NL	Netherlands
BF	Burkina Faso	HU	Hungary	NO	Norway
BG	Bulgaria	IE	Ireland	NZ	New Zealand
BJ	Benin	IT	Italy	PL	Poland
BR	Brazil	JP	Japan	PT	Portugal
BY	Belarus	KE	Kenya	RO	Romania
CA	Canada	KG	Kyrgystan	RU	Russian Federation
CF	Central African Republic	KP	Democratic People's Republic of Korea	SD	Sudan
CG	Congo	KR	Republic of Korea	SE	Sweden
CH	Switzerland	KZ	Kazakhstan	SI	Slovenia
CI	Côte d'Ivoire	LI	Liechtenstein	SK	Slovakia
CM	Cameroon	LU	Luxembourg	SN	Senegal
CN	China	LV	Latvia	TD	Chad
CS	Czechoslovakia	MC	Monaco	TG	Togo
CZ	Czech Republic	MD	Republic of Moldova	TJ	Tajikistan
DE	Germany	MG	Madagascar	TT	Trinidad and Tobago
DK	Denmark	ML	Mali	UA	Ukraine
ES	Spain	MN	Mongolia	US	United States of America
FI	Finland			UZ	Uzbekistan
FR	France			VN	Viet Nam
GA	Gabon				

TITLE

A Plasma Delipidation System.

TECHNICAL FIELD

5 This invention relates to a plasma delipidation system and in particular relates to a method and apparatus for continuously extracting lipids such as cholesterol from blood plasma of animals including humans.

BACKGROUND ART

10 Safe and effective methods for reducing severe hyperlipidaemia are of great importance in the treatment of coronary heart disease in humans and other animals. Hyperlipidaemia leads to the formation of atherosclerotic plaques with coronary heart disease being an inevitable
15 result.

Diet is the basic element of all therapy for hyperlipidaemia (excessive amount of fat in plasma). However, the use of diet as a primary mode of therapy requires a major effort on the part of physicians,
20 nutritionists, dietitians and other health professionals.

If dietary modification is unsuccessful, drug therapy is an alternative. Several drugs, used singly or in combination, are available. However, there is no direct evidence that any cholesterol-lowering drug can be
25 safely administered over an extended period.

A combination of both drug and diet may be required to reduce the concentration of plasma lipids. Hypolipidaemic drugs are therefore used as a supplement to dietary control.

30 Many drugs are effective in reducing blood lipids, but none work in all types of hyperlipoproteinemia and they all have undesirable side-effects. There is no conclusive evidence that hypolipidaemic drugs can cause regression of
35 atherosclerosis.

In view of the above, new approaches have been sought to reduce the amount of lipid in the plasma of homozygotes and that of heterozygotes for whom oral drugs

are not effective.

Plasmapheresis (plasma exchange) therapy has been developed and involves replacement of the patient's plasma with donor plasma or more usually a plasma protein fraction. This treatment can result in complications due to the possible introduction of foreign proteins and transmission of infectious diseases. Further, plasma exchange removes all the plasma proteins as well as very low density lipoprotein (VLDL), low density lipoprotein (LDL), and high density lipoprotein (HDL).

It is known that HDL is inversely correlated with the severity of coronary arterial lesions as well as with the likelihood that these will progress. Therefore, removal of HDL is not advantageous.

Known techniques also exist which can totally remove LDL from plasma. These techniques include absorption of LDL to heparinagarose beads (affinity chromatography) or the use of immobilised LDL-antibodies. Other methods presently available for the removal of LDL involve cascade filtration absorption to immobilised dextran sulphate and LDL precipitation at low pH in the presence of heparin. Each method specifically removes LDL but not HDL.

LDL aphaeresis has, however, disadvantages. Significant amounts of other plasma proteins are removed during aphaeresis and to obtain a sustained reduction in LDL-cholesterol, LDL aphaeresis must be performed frequently (up to once weekly). Furthermore, LDL removal may be counter productive: low blood LDL levels will result in increased cellular cholesterol synthesis.

To satisfy the need for a method of achieving a reduction in plasma cholesterol, and in particular LDL-cholesterol, in homozygous familial hypercholesterolemia and heterozygous familial hypercholesterolemia patients other than by diet and/or drug therapy, an extra corporeal lipid elimination process, termed "cholesterol aphaeresis", has been developed. In cholesterol aphaeresis blood is withdrawn from a subject, plasma

separated from the blood and mixed with a solvent mixture which extracts lipid from the plasma, after which the delipidated plasma is recombined with the blood cells and returned to the subject.

5 The advantage of this procedure is that LDL and HDL are not removed from the plasma but only cholesterol, some phospholipids and triglycerides are removed. Our earlier United States patent 4895558 describes this system.

10 While cholesterol aphaeresis has overcome the shortcomings of dietary and/or drug treatments and other aphaeretic techniques, existing apparatus for cholesterol aphaeresis does not provide a sufficiently rapid process. For use in a clinical setting, apparatus is required
15 which effects delipidation in a matter of minutes. Furthermore, flow rates of the order of 70 ml/min are required for cholesterol aphaeresis of a human subject.

SUMMARY OF THE INVENTION

20 It is an object of the invention to provide a system to allow extraction of cholesterol from animal plasma which may overcome the abovementioned disadvantages.

 In one form the invention resides in a method for removing cholesterol from animal plasma comprising
25 subjecting the plasma to a solvent extraction step to extract cholesterol from the plasma, and removing any remaining solvent from the plasma, characterised in that in the solvent extraction step, the plasma is dispersed into small droplets into the solvent by a dispersing
30 means thereby improving the rate of extraction of the cholesterol into the solvent.

 The plasma may be human plasma or plasma from other living animals. The plasma can be obtained from human or animal blood by known plasma separating
35 techniques which include centrifugal separation, filtration and the like.

 The solvent extraction step is suitably carried out as a continuous or semi-continuous process thereby

making the method suitable for continuously extracting cholesterol from plasma. The solvent extraction step may include one or more solvents which can rapidly extract cholesterol from the plasma but do not appreciably
5 extract desirable moieties such as LDL, HDL and VLDL.

Suitable solvents comprise mixtures of hydrocarbons, ethers and alcohols. To allow subsequent removal of any residual solvent from the plasma, it is preferred that the solvent has a relatively low boiling
10 point thereby enabling it to be removed by a combination of heat and possibly vacuum. Preferable solvents are mixtures of lower alcohols with lower ethers. The lower alcohols suitably include those which are not appreciably miscible with the plasma and these can include the
15 butanols (butan-1-ol and (butan-2-ol). C1-4 ethers are also preferred and these can include the propyl ethers (di-isopropyl ether, propyl ether). Other solvents which may be applicable can include amines, esters, hydrocarbons and mixtures providing that the solvent can
20 (1) rapidly and preferably remove cholesterol from the plasma, (2) is substantially immiscible with the plasma, (3) can be quickly removed from the plasma (if required), and (4) does not denature the desired moieties. Preferred solvent compositions are butanol with di-
25 isopropyl ether and these may be in the ratio of 20% - 40% of the alcohol with 80% - 60% of the ether.

The solvent extraction step may be carried out in a vessel containing the solvent, the vessel being provided with an inlet and an outlet. The inlet through
30 which the plasma may pass can be arranged to be either adjacent the upper or lower parts of the vessel depending principally on the density of the solvent with respect to the plasma. Thus, if the plasma is denser than the solvent, the inlet is preferably adjacent an upper part
35 of the vessel such that the plasma falls through the solvent under the influence of gravity to a lower portion of the vessel. Alternatively, if the plasma is less dense than the solvent, the inlet is preferably adjacent

a lower part of the vessel. For the preferred solvent system comprising butanol and di-isopropyl ether, the plasma is denser than the solvent mixture and therefore the inlet is preferably adjacent the upper part of the vessel.

The outlet may also be positioned to collect the plasma after it has been extracted by the solvent. Thus, if the plasma is denser than the solvent, the outlet can be positioned adjacent a lower part of the vessel. Conversely, the outlet may be positioned adjacent an upper part of the vessel should the plasma be less dense than the solvent.

To rapidly allow extraction of the plasma to occur (thereby reducing the time taken to delipidate the plasma), a dispersing means is provided. The dispersing means may be associated with the inlet to disperse the incoming liquid (eg plasma) into fine droplets. The dispersing means may also pass the droplets laterally into the solvent. This provides a distinct advantage over other forms of extraction by ensuring a maximum extraction ability of the solvent. The dispersion means may therefore comprise a spinner which can be rotatably mounted relative to the vessel. The plasma may be introduced into the spinner and then flung laterally out into the solvent by the centrifugal action. Suitably, the spinner also converts the plasma into fine droplets as it rotates.

The solvent extraction step may be used in a continuous manner whereby the plasma can be continuously passed through the inlet, extracted by the solvent and then passed through the outlet. It is found that by using the solvent extraction step as described above, the extraction time can be reduced to between 1 to 5 minutes as opposed to up to 30 minutes for other known techniques.

The delipidated plasma may comprise some entrained solvent which is usually in the form of an emulsion. The delipidated plasma may therefore be

treated with a de-emulsifying agent. The de-emulsifying agent may comprise ether and a preferred ether is diethyl ether. The delipidated plasma may be passed into a de-emulsifying vessel where it may be contacted with the ether. Again, it is preferred that the delipidated plasma is dispersed with the de-emulsifying agent in order to rapidly de-emulsify the plasma.

The de-emulsified delipidated plasma may be subjected to a further solvent removal step to remove any further solvent (including the de-emulsifying agent) to a acceptable level whereby the plasma can be reintroduced into the human or animal body. Of course, if no remaining solvent is present in the delipidated plasma, or if the level of any remaining solvent is acceptable, a solvent removing step may not be required.

Solvent extraction is a well known procedure whereby a solid or a liquid can have components extracted therefrom into the solvent. With liquid-liquid solvent extraction systems, the solvent and the liquid to be extracted should be substantially immiscible. The solvent should also, of course, be chosen to enable extraction of the desired compound from the liquid. To date, liquid-liquid solvent extraction systems have been conducted manually by shaking the two liquids together in a solvent extraction flask. It is also known to use automatic shakers to effect the same purpose.

A disadvantage with these known systems is that they cannot be used on a continuous basis. This is because the two liquids are vigorously shaken together and the vessel needs to be left standing for a period of time to enable the two liquids to separate. Vigorous shaking is required in order to maximise the solvent extraction step and also to allow the solvent extraction to occur as quickly as possible.

It is of course advantageous to have a solvent extraction step conducted continuously. If this could be achieved, the solvent extraction step could be used in association with other continuous processes which require

less handling, manpower and can be fully automated. A fully automated system has several advantages both for clinical uses and also for uses in industrial systems.

5 The present invention has been developed to provide a solvent extraction apparatus which enables solvent extraction to be carried out on a continuous basis. The apparatus can therefore be used either by itself, or in association with other automated processes. The apparatus enables rapid and efficient solvent
10 extraction to occur without requiring vigorous shaking of the solvent.

In another form, therefore, the invention resides in a solvent extraction apparatus comprising a vessel which can contain a first liquid, an inlet to
15 allow a second liquid to pass into the vessel, an outlet to allow the second liquid to exit from the vessel, and dispersing means associated with the inlet to disperse the second liquid into droplets as it passes into the vessel.

20 In this manner, the solvent extraction rate can be maximised and the apparatus can be used in a continuous or semi-continuous manner to allow incoming second liquid to be continuously extracted by the first liquid in the vessel.

25 The position of the inlet in the vessel may depend upon the relative densities between the first and second liquids. If the second liquid is heavier than the first liquid, the inlet is preferably located adjacent an upper part of the vessel. Conversely, if the second
30 liquid is lighter than the first liquid, the inlet is preferably located adjacent a lower part of the vessel.

Similarly, the location of the outlet will also depend upon the relative densities of the liquid. If the second liquid is heavier than the first liquid, the
35 outlet is preferably associated with a lower part of the vessel. Conversely, if the second liquid is lighter than the first liquid, the outlet is preferably associated with an upper part of the vessel. In order to assist

separation of the two liquids, the configuration of the vessel in the vicinity of the outlet may be narrowed or tapered relative to the main body of the vessel.

5 The dispersing means as well as dispersing the second liquid into small droplets, may also function to pass the droplets laterally into the vessel. This can be achieved by having the dispersing means in the form of a spinner. The spinner may be rotatably mounted relative to the vessel. The spinner may comprise a container into
10 which the second liquid can pass. The container may include means to disperse the liquid into droplets. This means may comprise beads (typically glass beads) in the container such that as the container spins about its axis, the beads will disperse the liquid into droplets.
15 The outer wall of the container is suitably perforated such that the dispersed liquid can pass through the wall of the container and laterally into the vessel. Alternatively, the means for dispersing the liquid may comprise a mesh or small apertures in the wall of the
20 container. It is preferred that the container is dimensioned, and is rotated such that second liquid is dispersed laterally substantially through the first liquid in the vessel. Of course, a skilled person will be able to determine the spin rate and size of the
25 container and will also need to take into account the viscosity of the second and the first fluid.

The solvent extraction apparatus can be used for a large range of liquids. These may include plasma and organic solvents, oils, scrubbing liquids and the
30 like.

BRIEF DESCRIPTION OF THE DRAWINGS

Figure 1 illustrates a schematic representation of a method for removing cholesterol from plasma.

35 Figure 2 depicts a solvent extraction apparatus.

BEST MODE

Referring now to figure 1, blood is removed from a subject (not shown) and enters into the system at

21 aided by pump 22. A drawing needle (not shown) is used to extract blood from the subject. Prime solution in reservoir 23 is mixed with the blood and an anti-coagulant from reservoir 24 is also combined with the
5 blood via pump 25. Pumps 22 and 25 are regulated by a venous pressure monitor.

The primed and anti-coagulant treated blood is then fed to a disposable centrifugal separator 27 of known design to separate the plasma (unfilled channel)
10 from blood cells (filled channel). Any waste in the plasma may be diverted to a waste bag 28.

The plasma is passed into a solvent extraction step 30 and is extracted by an apparatus which is more clearly described with reference to figure 2. The
15 apparatus 40 includes a vessel 41 having an inlet 42 and an outlet 43. Vessel 41 is filled with solvent which comprises peroxide free di-isopropyl ether and butanol in a 60 to 40 mixture. Inlet 42 comprises a steel tube which is rotatably mounted in a vertical manner by vessel
20 41. Plasma can pass through the tube through upper end 44 and to the lower end 45. Lower end 45 extends into a dispersing means 46 which is in the form of a cage like mesh container having a horizontal top and bottom wall, and a circular peripheral side wall. Top and bottom
25 walls are formed from continuous material while the circular side wall is formed from perforated material (in the embodiment a mesh). The container is packed with glass balls of approximately 2 millimetre diameter and the mesh is dimensioned to prevent the balls from passing
30 through the side wall of the container. The container can be rotated by a motor (not shown) and is typically rotated at 250 to 350 rpm. It can therefore be seen that as plasma passes through inlet 42 and into the container, the plasma will be forced against the glass balls and
35 thereby will be dispersed into small droplets before being flung out through the mesh side wall into the solvent which fills vessel 41. The container is completely submerged in the solvent and solvent can

freely pass into the container.

As the plasma passes into the rotating container, it is dispersed by the beads and flung out through the side wall and into the upper part of the solvent mixture. The fine droplets of plasma will then fall under the influence of gravity towards outlet 43. In the process, a rapid and efficient solvent extraction will take place. This is because the fine droplets continually contact fresh solvent as they pass downwardly through the solvent mixture.

The lower end of vessel 41 is necked to prevent the vortex created by the rotating dispersing means from creating undue turbulence in the lower part of vessel 41.

The delipidated plasma can then pass through outlet 43.

As some solvent is usually retained by the delipidated plasma in the form of a slight emulsion, the delipidated plasma is de-emulsified by passing it into a second vessel 47 (30A of figure 1) containing a de-emulsifying agent such as di-ethyl ether. In this vessel, an homogeniser 48 is provided and the delipidated plasma is initially passed into the vessel adjacent the turret 49 of the homogeniser. The action of the homogeniser disperses the delipidated and emulsified plasma into the ether. As the homogenisation takes place in an upper part of the vessel, the de-emulsified and delipidated plasma will drop to a lower part of the vessel 50 where it can separate from the ether and be collected.

Thereafter, as shown in figure 1, the delipidated de-emulsified plasma passes to a continuous solvent evaporator 31 where any remaining solvent and ether can be removed or reduced to a level which is no longer harmful to the subject. Replacement fluid solution from reservoir 32 can then be added to the plasma via pump 34 and the plasma is subsequently recombined with the red blood cells via pump 35 and the

reconstituted blood can then be returned to the subject via an infusion needle under the control of a level monitor 36.

5 The apparatus illustrated in figure 2 as well as being used for extracting cholesterol from plasma, can also be used for extraction of any suitable liquid-liquid system and therefore finds use in a wide range of applications.

10 Referring to figure 1, there is illustrated a method for removing cholesterol from plasma and in particular a continuous method for the continuous withdrawal of blood from a subject, extraction of cholesterol from the blood plasma and return of the reconstituted cholesterol depleted blood to the subject.

15 The system described in figure 1 can be used to provide a rapid continuous process in which a plasma volume of about 200 ml can be delipidated in several minutes.

20 It should be appreciated that various other changes and modifications may be made to the embodiment described without departing from the spirit and scope of the invention as claimed.

CLAIMS:

1. A method for removing cholesterol from animal plasma comprising subjecting the plasma to a solvent extraction step to extract cholesterol from the plasma, characterised in that in the solvent extraction step, the plasma is dispersed into small droplets into the solvent by a dispersing means thereby improving the rate of extraction of the cholesterol into the solvent.
2. The method of claim 1, wherein the solvent extraction step comprises a vessel containing the solvent, the vessel having an inlet to allow plasma to pass into the vessel and an outlet to allow delipidated plasma to be removed from the vessel, the dispersing means being associated with the inlet to disperse plasma passing through the inlet into small droplets.
3. The method of claim 2, wherein the dispersing means comprises a spinning container rotatably mounted relative to the vessel and having an inlet and outlet, and whereby plasma passes into the container through the inlet and passes through the outlet as small droplets.
4. The method of claim 3, wherein the dispersing means disperses the plasma laterally into the solvent.
5. The method of claim 4, wherein the spinning container includes packing material to assist in dispersing the plasma.
6. The method of claim 5, wherein the packing material comprises a multiplicity of spheres.
7. The method of claim 6, wherein the container is cylindrical and the outlet comprises a perforated side wall and where plasma exits the container through the perforated side wall and is dispersed into the solvent.
8. The method of claim 7, wherein the solvent comprises 20-40% of a lower alcohol and 80-60% of a lower ether.
9. The method of claim 1, wherein plasma passing from the solvent extraction step is subjected to a de-emulsification step.
10. The method of claim 9, comprising the steps of

extracting blood from an animal, plasma is separated from the blood, the plasma is subjected to the solvent extraction step, the extracted plasma is subjected to the de-emulsification step, the de-emulsificated plasma is recombined with the removed blood and reintroduced into the animal.

5
10 11. A solvent extraction apparatus comprising a vessel for containing solvent, the vessel having an inlet and an outlet, and dispersing means associated with the inlet to disperse liquid passing through the inlet into small droplets.

15 12. The apparatus of claim 11, wherein the dispersing means comprises a spinning container having an inlet and an outlet, the container being positioned within the vessel, the inlet of the container being associated with the inlet of the vessel.

20 13. The apparatus of claim 12, wherein the container is a hollow cylinder having a perforated peripheral side wall which comprises the outlet.

25 14. The apparatus of claim 13, wherein the interior of the container contains packing material to assist in dispersing the liquid into small droplets.

30 15. The apparatus of claim 14, wherein the packing material comprises a multiplicity of spheres.

35 16. A solvent extraction apparatus comprising a vessel to contain solvent the vessel having an upper inlet and a lower outlet, a dispersing means in the form of a hollow cylindrical container having a perforated peripheral sidewall outlet and packing material within the container, and being mounted for rotation within the vessel and below the level of solvent in the vessel, the container having an inlet in communication with the inlet of the vessel such that liquid passing into the vessel passes into the container.

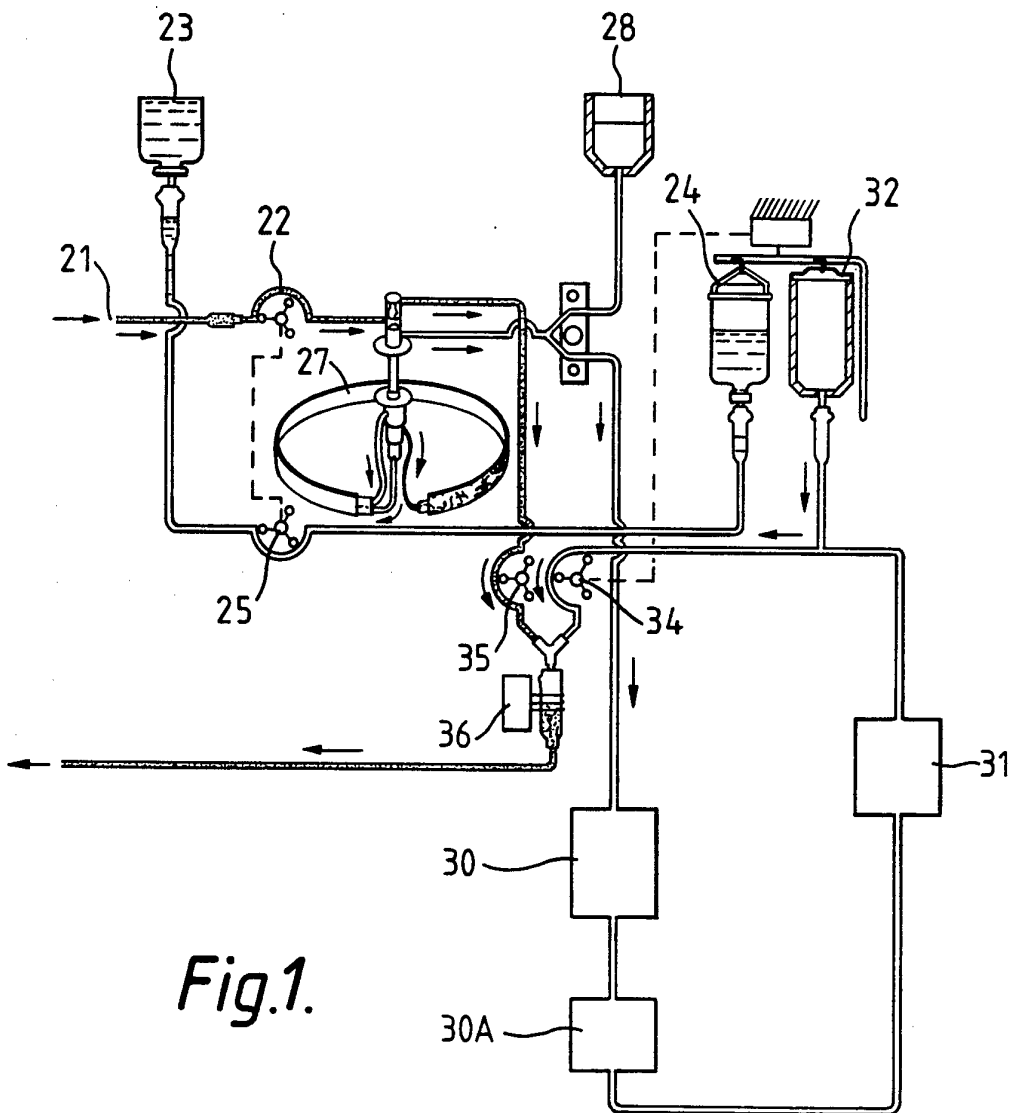

Fig.1.

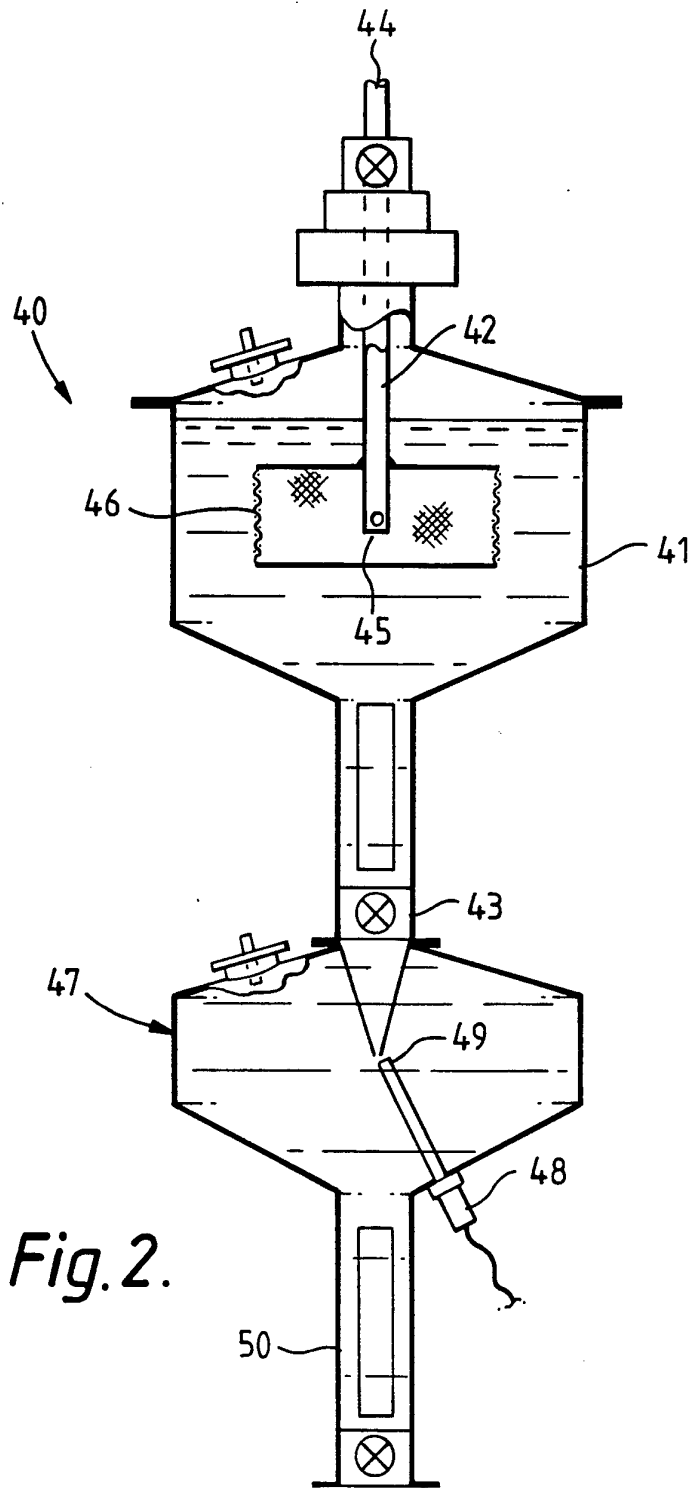

Fig. 2.

C(Continuation). DOCUMENTS CONSIDERED TO BE RELEVANT		
Category *	Citation of document, with indication, where appropriate of the relevant passages	Relevant to Claim No.
X Y	Patent Abstracts of Japan, C-36, page 117, JP,A, 55-127104 (SEIKOUEN HOSONO SHINRIYOUSHIYO) 1 October 1980 (01.10.80)	11 1, 2
X Y	EP,A, 36283 (DAVY MCKEE (MINERALS & METALS) LIMITED) 23 September 1981 (23.09.81)	11 1, 2
Y A	EP,A, 267471 (PENNWALT CORPORATION) 18 May 1988 (18.05.88) page 3, lines 17-20	14, 16 5, 6, 15
A	Patent Abstracts of Japan, C-1159, page 159, JP,A, 5-277303 (TOCHIMOTO TENKAIDOU K.K.) 26 October 1993 (26.10.93)	1-16

INTERNATIONAL SEARCH REPORT

Information on patent family members

International application No.

PCT/AU 94/00415

This Annex lists the known "A" publication level patent family members relating to the patent documents cited in the above-mentioned international search report. The Australian Patent Office is in no way liable for these particulars which are merely given for the purpose of information.

Patent Document Cited in Search Report		Patent Family Member					
EP	36283	AU	68531/81	CA	1154573	US	4391711
EP	267471	AU	80158/87	CA	1290925	JP	63120739
		US	4855113				
US	4895558						
END OF ANNEX							